



Full wwPDB X-ray Structure Validation Report ⓘ

Mar 10, 2026 – 12:09 PM UTC

PDB ID : 2AFA / pdb_00002afa
Title : Crystal Structure of putative NAG isomerase from Salmonella typhimurium
Authors : Kumaran, D.; Swaminathan, S.; Burley, S.K.; New York SGX Research Center
for Structural Genomics (NYSGXRC)
Deposited on : 2005-07-25
Resolution : 2.15 Å(reported)

This is a Full wwPDB X-ray Structure Validation Report for a publicly released PDB entry.

We welcome your comments at validation@mail.wwpdb.org

A user guide is available at

<https://www.wwpdb.org/validation/2017/XrayValidationReportHelp>

with specific help available everywhere you see the ⓘ symbol.

The types of validation reports are described at

<http://www.wwpdb.org/validation/2017/FAQs#types>.

The following versions of software and data (see [references ⓘ](#)) were used in the production of this report:

MolProbity : 4-5-2 with Phenix2.0
Mogul : 2022.3.0, CSD as543be (2022)
Xtriage (Phenix) : 2.0
EDS : 3.0
Percentile statistics : 20250101.v01 (using entries in the PDB archive January 1st 2025)
CCP4 : 9.0.010 (Gargrove)
Density-Fitness : 1.0.12
Ideal geometry (proteins) : Engh & Huber (2001)
Ideal geometry (DNA, RNA) : Parkinson et al. (1996)
Validation Pipeline (wwPDB-VP) : 2.49

1 Overall quality at a glance

The following experimental techniques were used to determine the structure:

X-RAY DIFFRACTION

The reported resolution of this entry is 2.15 Å.

Percentile scores (ranging between 0-100) for global validation metrics of the entry are shown in the following graphic. The table shows the number of entries on which the scores are based.

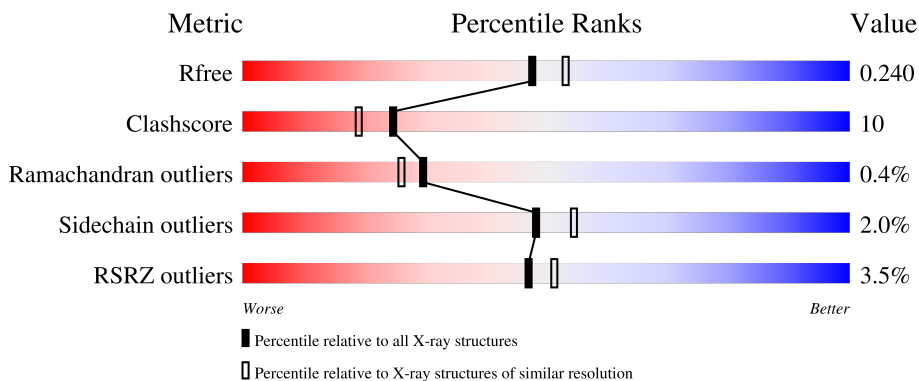

Metric	Whole archive (#Entries)	Similar resolution (#Entries, resolution range(Å))
R_{free}	180053	2057 (2.16-2.16)
Clashscore	190562	2159 (2.16-2.16)
Ramachandran outliers	187476	2134 (2.16-2.16)
Sidechain outliers	187428	2133 (2.16-2.16)
RSRZ outliers	180081	2059 (2.16-2.16)

The table below summarises the geometric issues observed across the polymeric chains and their fit to the electron density. The red, orange, yellow and green segments of the lower bar indicate the fraction of residues that contain outliers for ≥ 3 , 2, 1 and 0 types of geometric quality criteria respectively. A grey segment represents the fraction of residues that are not modelled. The numeric value for each fraction is indicated below the corresponding segment, with a dot representing fractions $\leq 5\%$. The upper red bar (where present) indicates the fraction of residues that have poor fit to the electron density. The numeric value is given above the bar.

Mol	Chain	Length	Quality of chain
1	A	425	 2% 74% 21% . .
1	B	425	 3% 70% 24% . .
1	C	425	 4% 70% 24% . .
1	D	425	 4% 69% 25% . .
1	E	425	 5% 72% 23% . .

Continued on next page...

Continued from previous page...

Mol	Chain	Length	Quality of chain
1	F	425	 <p>2% 77% 18% . .</p>

2 Entry composition [i](#)

There are 2 unique types of molecules in this entry. The entry contains 20569 atoms, of which 0 are hydrogens and 0 are deuteriums.

In the tables below, the ZeroOcc column contains the number of atoms modelled with zero occupancy, the AltConf column contains the number of residues with at least one atom in alternate conformation and the Trace column contains the number of residues modelled with at most 2 atoms.

- Molecule 1 is a protein called NAG isomerase.

Mol	Chain	Residues	Atoms						ZeroOcc	AltConf	Trace
			Total	C	N	O	S	Se			
1	A	408	3318	2131	573	601	4	9	0	0	0
1	B	408	3318	2131	573	601	4	9	0	0	0
1	C	408	3318	2131	573	601	4	9	0	0	0
1	D	408	3318	2131	573	601	4	9	0	0	0
1	E	408	3318	2131	573	601	4	9	0	0	0
1	F	408	3318	2131	573	601	4	9	0	0	0

There are 132 discrepancies between the modelled and reference sequences:

Chain	Residue	Modelled	Actual	Comment	Reference
A	1	MSE	-	cloning artifact	UNP Q8ZKT7
A	2	SER	-	cloning artifact	UNP Q8ZKT7
A	3	LEU	-	cloning artifact	UNP Q8ZKT7
A	48	MSE	MET	modified residue	UNP Q8ZKT7
A	58	MSE	MET	modified residue	UNP Q8ZKT7
A	68	MSE	MET	modified residue	UNP Q8ZKT7
A	84	MSE	MET	modified residue	UNP Q8ZKT7
A	155	MSE	MET	modified residue	UNP Q8ZKT7
A	177	MSE	MET	modified residue	UNP Q8ZKT7
A	258	MSE	MET	modified residue	UNP Q8ZKT7
A	325	MSE	MET	modified residue	UNP Q8ZKT7
A	356	MSE	MET	modified residue	UNP Q8ZKT7
A	417	GLU	-	cloning artifact	UNP Q8ZKT7
A	418	GLY	-	cloning artifact	UNP Q8ZKT7
A	419	GLY	-	cloning artifact	UNP Q8ZKT7
A	420	SER	-	cloning artifact	UNP Q8ZKT7
A	421	HIS	-	expression tag	UNP Q8ZKT7

Continued on next page...

Continued from previous page...

Chain	Residue	Modelled	Actual	Comment	Reference
A	422	HIS	-	expression tag	UNP Q8ZKT7
A	423	HIS	-	expression tag	UNP Q8ZKT7
A	424	HIS	-	expression tag	UNP Q8ZKT7
A	425	HIS	-	expression tag	UNP Q8ZKT7
A	426	HIS	-	expression tag	UNP Q8ZKT7
B	1	MSE	-	cloning artifact	UNP Q8ZKT7
B	2	SER	-	cloning artifact	UNP Q8ZKT7
B	3	LEU	-	cloning artifact	UNP Q8ZKT7
B	48	MSE	MET	modified residue	UNP Q8ZKT7
B	58	MSE	MET	modified residue	UNP Q8ZKT7
B	68	MSE	MET	modified residue	UNP Q8ZKT7
B	84	MSE	MET	modified residue	UNP Q8ZKT7
B	155	MSE	MET	modified residue	UNP Q8ZKT7
B	177	MSE	MET	modified residue	UNP Q8ZKT7
B	258	MSE	MET	modified residue	UNP Q8ZKT7
B	325	MSE	MET	modified residue	UNP Q8ZKT7
B	356	MSE	MET	modified residue	UNP Q8ZKT7
B	417	GLU	-	cloning artifact	UNP Q8ZKT7
B	418	GLY	-	cloning artifact	UNP Q8ZKT7
B	419	GLY	-	cloning artifact	UNP Q8ZKT7
B	420	SER	-	cloning artifact	UNP Q8ZKT7
B	421	HIS	-	expression tag	UNP Q8ZKT7
B	422	HIS	-	expression tag	UNP Q8ZKT7
B	423	HIS	-	expression tag	UNP Q8ZKT7
B	424	HIS	-	expression tag	UNP Q8ZKT7
B	425	HIS	-	expression tag	UNP Q8ZKT7
B	426	HIS	-	expression tag	UNP Q8ZKT7
C	1	MSE	-	cloning artifact	UNP Q8ZKT7
C	2	SER	-	cloning artifact	UNP Q8ZKT7
C	3	LEU	-	cloning artifact	UNP Q8ZKT7
C	48	MSE	MET	modified residue	UNP Q8ZKT7
C	58	MSE	MET	modified residue	UNP Q8ZKT7
C	68	MSE	MET	modified residue	UNP Q8ZKT7
C	84	MSE	MET	modified residue	UNP Q8ZKT7
C	155	MSE	MET	modified residue	UNP Q8ZKT7
C	177	MSE	MET	modified residue	UNP Q8ZKT7
C	258	MSE	MET	modified residue	UNP Q8ZKT7
C	325	MSE	MET	modified residue	UNP Q8ZKT7
C	356	MSE	MET	modified residue	UNP Q8ZKT7
C	417	GLU	-	cloning artifact	UNP Q8ZKT7
C	418	GLY	-	cloning artifact	UNP Q8ZKT7
C	419	GLY	-	cloning artifact	UNP Q8ZKT7

Continued on next page...

Continued from previous page...

Chain	Residue	Modelled	Actual	Comment	Reference
C	420	SER	-	cloning artifact	UNP Q8ZKT7
C	421	HIS	-	expression tag	UNP Q8ZKT7
C	422	HIS	-	expression tag	UNP Q8ZKT7
C	423	HIS	-	expression tag	UNP Q8ZKT7
C	424	HIS	-	expression tag	UNP Q8ZKT7
C	425	HIS	-	expression tag	UNP Q8ZKT7
C	426	HIS	-	expression tag	UNP Q8ZKT7
D	1	MSE	-	cloning artifact	UNP Q8ZKT7
D	2	SER	-	cloning artifact	UNP Q8ZKT7
D	3	LEU	-	cloning artifact	UNP Q8ZKT7
D	48	MSE	MET	modified residue	UNP Q8ZKT7
D	58	MSE	MET	modified residue	UNP Q8ZKT7
D	68	MSE	MET	modified residue	UNP Q8ZKT7
D	84	MSE	MET	modified residue	UNP Q8ZKT7
D	155	MSE	MET	modified residue	UNP Q8ZKT7
D	177	MSE	MET	modified residue	UNP Q8ZKT7
D	258	MSE	MET	modified residue	UNP Q8ZKT7
D	325	MSE	MET	modified residue	UNP Q8ZKT7
D	356	MSE	MET	modified residue	UNP Q8ZKT7
D	417	GLU	-	cloning artifact	UNP Q8ZKT7
D	418	GLY	-	cloning artifact	UNP Q8ZKT7
D	419	GLY	-	cloning artifact	UNP Q8ZKT7
D	420	SER	-	cloning artifact	UNP Q8ZKT7
D	421	HIS	-	expression tag	UNP Q8ZKT7
D	422	HIS	-	expression tag	UNP Q8ZKT7
D	423	HIS	-	expression tag	UNP Q8ZKT7
D	424	HIS	-	expression tag	UNP Q8ZKT7
D	425	HIS	-	expression tag	UNP Q8ZKT7
D	426	HIS	-	expression tag	UNP Q8ZKT7
E	1	MSE	-	cloning artifact	UNP Q8ZKT7
E	2	SER	-	cloning artifact	UNP Q8ZKT7
E	3	LEU	-	cloning artifact	UNP Q8ZKT7
E	48	MSE	MET	modified residue	UNP Q8ZKT7
E	58	MSE	MET	modified residue	UNP Q8ZKT7
E	68	MSE	MET	modified residue	UNP Q8ZKT7
E	84	MSE	MET	modified residue	UNP Q8ZKT7
E	155	MSE	MET	modified residue	UNP Q8ZKT7
E	177	MSE	MET	modified residue	UNP Q8ZKT7
E	258	MSE	MET	modified residue	UNP Q8ZKT7
E	325	MSE	MET	modified residue	UNP Q8ZKT7
E	356	MSE	MET	modified residue	UNP Q8ZKT7
E	417	GLU	-	cloning artifact	UNP Q8ZKT7

Continued on next page...

Continued from previous page...

Chain	Residue	Modelled	Actual	Comment	Reference
E	418	GLY	-	cloning artifact	UNP Q8ZKT7
E	419	GLY	-	cloning artifact	UNP Q8ZKT7
E	420	SER	-	cloning artifact	UNP Q8ZKT7
E	421	HIS	-	expression tag	UNP Q8ZKT7
E	422	HIS	-	expression tag	UNP Q8ZKT7
E	423	HIS	-	expression tag	UNP Q8ZKT7
E	424	HIS	-	expression tag	UNP Q8ZKT7
E	425	HIS	-	expression tag	UNP Q8ZKT7
E	426	HIS	-	expression tag	UNP Q8ZKT7
F	1	MSE	-	cloning artifact	UNP Q8ZKT7
F	2	SER	-	cloning artifact	UNP Q8ZKT7
F	3	LEU	-	cloning artifact	UNP Q8ZKT7
F	48	MSE	MET	modified residue	UNP Q8ZKT7
F	58	MSE	MET	modified residue	UNP Q8ZKT7
F	68	MSE	MET	modified residue	UNP Q8ZKT7
F	84	MSE	MET	modified residue	UNP Q8ZKT7
F	155	MSE	MET	modified residue	UNP Q8ZKT7
F	177	MSE	MET	modified residue	UNP Q8ZKT7
F	258	MSE	MET	modified residue	UNP Q8ZKT7
F	325	MSE	MET	modified residue	UNP Q8ZKT7
F	356	MSE	MET	modified residue	UNP Q8ZKT7
F	417	GLU	-	cloning artifact	UNP Q8ZKT7
F	418	GLY	-	cloning artifact	UNP Q8ZKT7
F	419	GLY	-	cloning artifact	UNP Q8ZKT7
F	420	SER	-	cloning artifact	UNP Q8ZKT7
F	421	HIS	-	expression tag	UNP Q8ZKT7
F	422	HIS	-	expression tag	UNP Q8ZKT7
F	423	HIS	-	expression tag	UNP Q8ZKT7
F	424	HIS	-	expression tag	UNP Q8ZKT7
F	425	HIS	-	expression tag	UNP Q8ZKT7
F	426	HIS	-	expression tag	UNP Q8ZKT7

- Molecule 2 is water.

Mol	Chain	Residues	Atoms	ZeroOcc	AltConf
2	A	121	Total O 121 121	0	0
2	B	98	Total O 98 98	0	0
2	C	113	Total O 113 113	0	0
2	D	115	Total O 115 115	0	0

Continued on next page...

Continued from previous page...

Mol	Chain	Residues	Atoms	ZeroOcc	AltConf
2	E	87	Total O 87 87	0	0
2	F	127	Total O 127 127	0	0

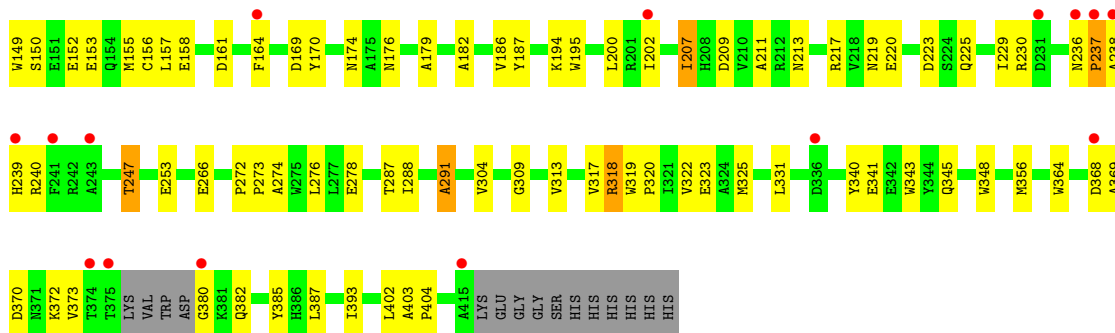

• Molecule 1: NAG isomerase

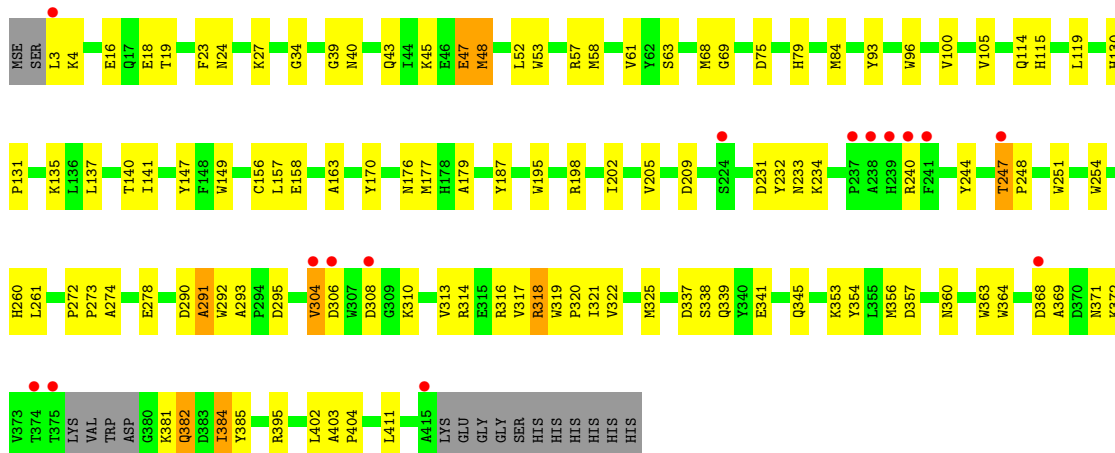

• Molecule 1: NAG isomerase

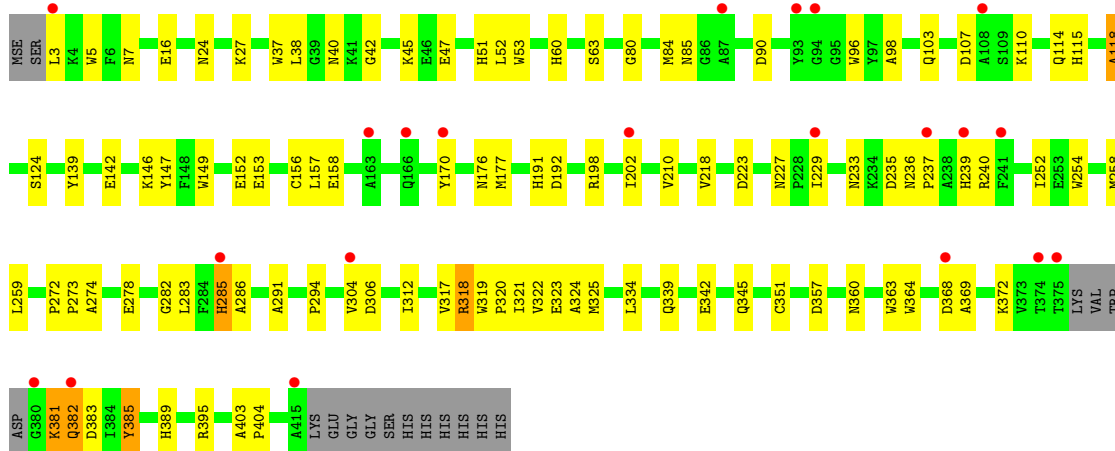
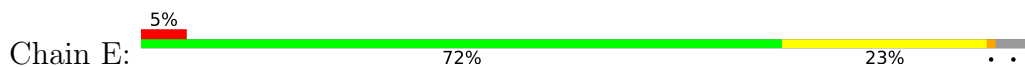

• Molecule 1: NAG isomerase

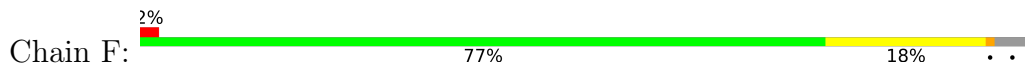

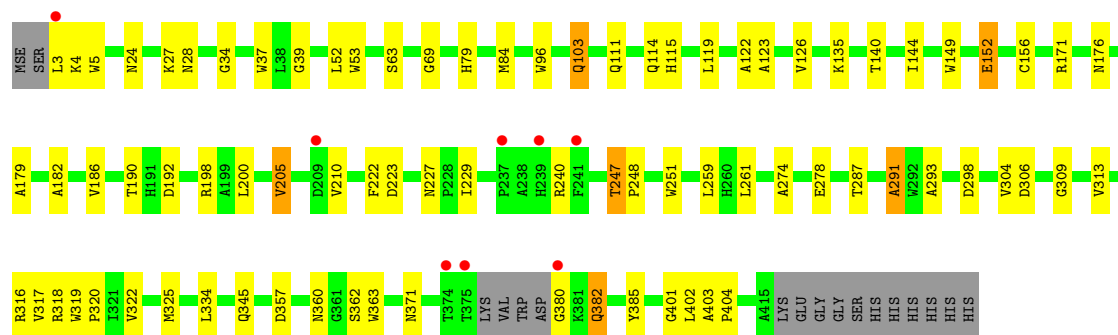

4 Data and refinement statistics i

Property	Value	Source
Space group	P 1	Depositor
Cell constants a, b, c, α , β , γ	88.93Å 91.14Å 95.10Å 106.81° 103.52° 111.79°	Depositor
Resolution (Å)	45.77 – 2.15 45.77 – 2.15	Depositor EDS
% Data completeness (in resolution range)	95.4 (45.77-2.15) 95.5 (45.77-2.15)	Depositor EDS
R_{merge}	0.08	Depositor
R_{sym}	(Not available)	Depositor
$\langle I/\sigma(I) \rangle$ ¹	2.71 (at 2.16Å)	Xtrriage
Refinement program	CNS 1.1	Depositor
R, R_{free}	0.207 , 0.246 0.205 , 0.240	Depositor DCC
R_{free} test set	2517 reflections (1.90%)	wwPDB-VP
Wilson B-factor (Å ²)	30.1	Xtrriage
Anisotropy	0.281	Xtrriage
Bulk solvent k_{sol} (e/Å ³), B_{sol} (Å ²)	0.34 , 37.5	EDS
L-test for twinning ²	$\langle L \rangle = 0.49$, $\langle L^2 \rangle = 0.32$	Xtrriage
Estimated twinning fraction	0.009 for -k,-h,-l	Xtrriage
F_o, F_c correlation	0.95	EDS
Total number of atoms	20569	wwPDB-VP
Average B, all atoms (Å ²)	33.0	wwPDB-VP

Xtrriage's analysis on translational NCS is as follows: *The largest off-origin peak in the Patterson function is 3.96% of the height of the origin peak. No significant pseudotranslation is detected.*

¹Intensities estimated from amplitudes.

²Theoretical values of $\langle |L| \rangle$, $\langle L^2 \rangle$ for acentric reflections are 0.5, 0.333 respectively for untwinned datasets, and 0.375, 0.2 for perfectly twinned datasets.

5 Model quality i

5.1 Standard geometry i

The Z score for a bond length (or angle) is the number of standard deviations the observed value is removed from the expected value. A bond length (or angle) with $|Z| > 5$ is considered an outlier worth inspection. RMSZ is the root-mean-square of all Z scores of the bond lengths (or angles).

Mol	Chain	Bond lengths		Bond angles	
		RMSZ	# Z >5	RMSZ	# Z >5
1	A	0.43	0/3414	0.93	8/4633 (0.2%)
1	B	0.41	0/3414	0.93	8/4633 (0.2%)
1	C	0.41	0/3414	0.93	13/4633 (0.3%)
1	D	0.41	0/3414	0.93	10/4633 (0.2%)
1	E	0.41	0/3414	0.92	8/4633 (0.2%)
1	F	0.42	0/3414	0.92	8/4633 (0.2%)
All	All	0.42	0/20484	0.93	55/27798 (0.2%)

There are no bond length outliers.

All (55) bond angle outliers are listed below:

Mol	Chain	Res	Type	Atoms	Z	Observed(°)	Ideal(°)
1	E	318	ARG	N-CA-C	8.44	120.10	111.07
1	A	63	SER	N-CA-C	-7.77	102.89	111.36
1	B	318	ARG	N-CA-C	7.66	119.31	110.97
1	C	369	ALA	N-CA-C	-7.63	103.23	112.54
1	E	369	ALA	N-CA-C	-7.62	103.96	113.18
1	E	63	SER	N-CA-C	-7.61	103.06	111.36
1	D	63	SER	N-CA-C	-7.58	103.10	111.36
1	A	291	ALA	N-CA-C	7.54	122.77	113.50
1	D	369	ALA	N-CA-C	-7.29	104.36	113.18
1	C	318	ARG	N-CA-C	6.96	118.56	110.97
1	C	63	SER	N-CA-C	-6.81	103.93	111.36
1	D	260	HIS	N-CA-C	-6.58	104.19	111.36
1	F	63	SER	N-CA-C	-6.57	104.19	111.36
1	E	118	ALA	N-CA-C	-6.54	104.23	111.36
1	B	63	SER	N-CA-C	-6.39	103.83	111.69
1	C	179	ALA	N-CA-C	-6.31	103.71	111.40
1	A	318	ARG	N-CA-C	6.24	117.88	111.14
1	C	291	ALA	N-CA-C	6.21	121.92	113.97
1	D	291	ALA	N-CA-C	6.21	121.80	113.72
1	F	247	THR	CA-C-N	6.18	127.57	119.84
1	F	247	THR	C-N-CA	6.18	127.57	119.84

Continued on next page...

Continued from previous page...

Mol	Chain	Res	Type	Atoms	Z	Observed(°)	Ideal(°)
1	C	247	THR	CA-C-N	6.10	127.46	119.84
1	C	247	THR	C-N-CA	6.10	127.46	119.84
1	C	147	TYR	N-CA-C	6.08	121.75	113.97
1	E	192	ASP	N-CA-C	-6.08	99.25	108.67
1	A	206	ILE	N-CA-C	6.07	116.85	110.72
1	B	291	ALA	N-CA-C	5.99	120.87	113.50
1	B	161	ASP	N-CA-C	-5.95	103.09	110.41
1	F	318	ARG	N-CA-C	5.81	117.31	110.97
1	C	217	ARG	N-CA-C	-5.67	99.48	108.73
1	F	205	VAL	N-CA-C	5.65	115.89	110.74
1	A	147	TYR	N-CA-C	5.63	121.57	114.31
1	B	192	ASP	N-CA-C	-5.62	99.37	108.41
1	C	194	LYS	N-CA-C	5.61	117.84	111.11
1	D	318	ARG	N-CA-C	5.58	117.05	110.97
1	F	291	ALA	N-CA-C	5.57	121.10	113.97
1	C	161	ASP	N-CA-C	-5.53	102.71	110.35
1	D	247	THR	CA-C-N	5.47	126.68	119.84
1	D	247	THR	C-N-CA	5.47	126.68	119.84
1	D	338	SER	N-CA-C	5.36	118.61	111.75
1	D	179	ALA	N-CA-C	-5.32	105.56	111.36
1	C	207	ILE	N-CA-C	5.29	116.45	111.48
1	B	247	THR	CA-C-N	5.26	126.42	119.84
1	B	247	THR	C-N-CA	5.26	126.42	119.84
1	E	291	ALA	N-CA-C	5.25	120.69	113.97
1	B	147	TYR	N-CA-C	5.25	121.41	114.12
1	E	85	ASN	N-CA-C	-5.22	105.57	112.94
1	C	23	PHE	N-CA-C	-5.21	105.61	111.28
1	A	112	GLY	N-CA-C	5.18	118.51	112.50
1	E	218	VAL	N-CA-C	5.16	115.65	108.84
1	F	190	THR	N-CA-C	-5.15	108.75	114.62
1	D	234	LYS	N-CA-C	-5.14	106.86	113.23
1	A	179	ALA	N-CA-C	-5.12	105.61	111.14
1	A	161	ASP	N-CA-C	-5.04	104.03	110.53
1	F	179	ALA	N-CA-C	-5.02	105.72	111.14

There are no chirality outliers.

There are no planarity outliers.

5.2 Too-close contacts

In the following table, the Non-H and H(model) columns list the number of non-hydrogen atoms and hydrogen atoms in the chain respectively. The H(added) column lists the number of hydrogen

atoms added and optimized by MolProbity. The Clashes column lists the number of clashes within the asymmetric unit, whereas Symm-Clashes lists symmetry-related clashes.

Mol	Chain	Non-H	H(model)	H(added)	Clashes	Symm-Clashes
1	A	3318	0	3137	60	0
1	B	3318	0	3137	66	0
1	C	3318	0	3137	69	0
1	D	3318	0	3137	79	0
1	E	3318	0	3137	66	0
1	F	3318	0	3137	52	0
2	A	121	0	0	3	0
2	B	98	0	0	4	0
2	C	113	0	0	5	0
2	D	115	0	0	3	0
2	E	87	0	0	3	0
2	F	127	0	0	3	0
All	All	20569	0	18822	381	0

The all-atom clashscore is defined as the number of clashes found per 1000 atoms (including hydrogen atoms). The all-atom clashscore for this structure is 10.

All (381) close contacts within the same asymmetric unit are listed below, sorted by their clash magnitude.

Atom-1	Atom-2	Interatomic distance (Å)	Clash overlap (Å)
1:E:306:ASP:HB3	1:E:312:ILE:HD11	1.48	0.94
1:D:156:CYS:H	1:D:176:ASN:HD21	1.27	0.82
1:E:176:ASN:HD22	1:E:202:ILE:HD12	1.44	0.82
1:F:156:CYS:H	1:F:176:ASN:HD21	1.29	0.79
1:C:156:CYS:H	1:C:176:ASN:HD21	1.32	0.78
1:E:259:LEU:HD22	1:E:334:LEU:HD12	1.66	0.77
1:D:58:MSE:SE	1:D:384:ILE:HD11	2.35	0.76
1:B:189:VAL:HG23	2:B:498:HOH:O	1.86	0.75
1:A:3:LEU:HD23	1:A:4:LYS:HG3	1.67	0.74
1:E:156:CYS:H	1:E:176:ASN:HD21	1.33	0.73
1:E:40:ASN:HA	1:E:381:LYS:HE2	1.70	0.73
1:F:274:ALA:O	1:F:278:GLU:HG3	1.89	0.72
1:B:29:ALA:HA	1:B:44:ILE:HD11	1.71	0.72
1:D:48:MSE:HE2	1:D:48:MSE:HA	1.70	0.72
1:C:96:TRP:H	1:C:115:HIS:HE1	1.38	0.71
1:D:176:ASN:HD22	1:D:202:ILE:HD12	1.54	0.71
1:C:368:ASP:HB2	1:C:372:LYS:H	1.55	0.71
1:F:37:TRP:CE2	1:F:382:GLN:HG2	2.25	0.71
1:A:156:CYS:H	1:A:176:ASN:HD21	1.39	0.70

Continued on next page...

Continued from previous page...

Atom-1	Atom-2	Interatomic distance (Å)	Clash overlap (Å)
1:E:322:VAL:HA	1:E:325:MSE:HE3	1.73	0.70
1:A:39:GLY:HA3	1:A:43:GLN:NE2	2.07	0.70
1:D:306:ASP:OD2	1:D:310:LYS:HB3	1.92	0.69
1:B:259:LEU:HD22	1:B:334:LEU:HD12	1.73	0.69
1:D:39:GLY:HA3	1:D:43:GLN:NE2	2.07	0.69
1:F:135:LYS:HG3	2:F:484:HOH:O	1.92	0.69
1:B:156:CYS:H	1:B:176:ASN:HD21	1.41	0.68
1:B:137:LEU:O	1:B:141:ILE:HG12	1.93	0.68
1:F:3:LEU:HD23	1:F:4:LYS:HG3	1.74	0.68
1:C:137:LEU:O	1:C:141:ILE:HG12	1.93	0.68
1:C:237:PRO:HD2	1:C:239:HIS:NE2	2.09	0.68
1:E:3:LEU:N	2:E:490:HOH:O	2.27	0.68
1:C:24:ASN:O	1:C:27:LYS:HG2	1.93	0.67
1:F:317:VAL:O	1:F:320:PRO:HD2	1.95	0.67
1:B:317:VAL:O	1:B:320:PRO:HD2	1.94	0.67
1:D:322:VAL:HA	1:D:325:MSE:HE3	1.77	0.67
1:B:24:ASN:O	1:B:27:LYS:HG2	1.96	0.66
1:C:322:VAL:HA	1:C:325:MSE:HE3	1.77	0.66
1:F:152:GLU:CD	1:F:152:GLU:H	2.04	0.66
1:A:318:ARG:HD3	1:A:364:TRP:O	1.97	0.65
1:D:53:TRP:HB3	1:D:114:GLN:HG2	1.78	0.65
1:D:53:TRP:HH2	1:D:382:GLN:HE21	1.44	0.65
1:D:45:LYS:HB3	1:D:47:GLU:OE2	1.97	0.65
1:A:191:HIS:HD2	1:D:187:TYR:OH	1.80	0.65
1:A:322:VAL:HA	1:A:325:MSE:HE3	1.80	0.64
1:A:348:TRP:HB3	1:B:71:PRO:HB3	1.80	0.64
1:D:240:ARG:HG3	1:D:240:ARG:HH11	1.61	0.64
1:B:190:THR:HG23	2:B:498:HOH:O	1.98	0.64
1:C:96:TRP:H	1:C:115:HIS:CE1	2.17	0.63
1:E:235:ASP:C	1:E:237:PRO:HD3	2.24	0.63
1:B:322:VAL:HA	1:B:325:MSE:HE3	1.79	0.63
1:E:223:ASP:HB3	1:E:229:ILE:HD11	1.80	0.63
1:C:403:ALA:HB3	1:C:404:PRO:HD3	1.82	0.61
1:F:223:ASP:OD2	1:F:227:ASN:HB2	2.00	0.61
1:C:156:CYS:H	1:C:176:ASN:ND2	1.99	0.61
1:A:53:TRP:HB3	1:A:114:GLN:HG2	1.83	0.61
1:E:223:ASP:OD2	1:E:227:ASN:HB2	2.00	0.61
1:A:306:ASP:HB3	1:A:310:LYS:O	2.01	0.60
1:E:317:VAL:O	1:E:320:PRO:HD2	2.01	0.60
1:E:3:LEU:C	1:E:345:GLN:HE22	2.09	0.60
1:C:220:GLU:HB2	2:C:518:HOH:O	2.01	0.60

Continued on next page...

Continued from previous page...

Atom-1	Atom-2	Interatomic distance (Å)	Clash overlap (Å)
1:E:149:TRP:HZ3	1:E:202:ILE:HD11	1.67	0.60
1:E:318:ARG:HD3	1:E:364:TRP:O	2.01	0.60
1:C:176:ASN:HD22	1:C:202:ILE:HD12	1.66	0.59
1:D:403:ALA:HB3	1:D:404:PRO:HD3	1.84	0.59
1:D:149:TRP:HZ3	1:D:202:ILE:HD11	1.67	0.59
1:A:259:LEU:HD22	1:A:334:LEU:HD12	1.84	0.59
1:C:240:ARG:HH12	1:C:313:VAL:HG11	1.68	0.59
1:A:168:GLU:HG2	1:A:170:TYR:HB3	1.84	0.58
1:D:24:ASN:O	1:D:27:LYS:HG2	2.03	0.58
1:C:318:ARG:HD3	1:C:364:TRP:O	2.04	0.58
1:F:24:ASN:O	1:F:27:LYS:HG2	2.03	0.58
1:B:393:ILE:HB	1:B:394:PRO:HD3	1.86	0.58
1:A:47:GLU:OE1	1:A:48:MSE:HE3	2.03	0.58
1:D:137:LEU:O	1:D:141:ILE:HG12	2.04	0.58
1:F:3:LEU:N	2:F:517:HOH:O	2.36	0.58
1:C:152:GLU:HG2	1:C:153:GLU:N	2.20	0.57
1:D:177:MSE:HB2	1:D:254:TRP:CZ2	2.40	0.57
1:B:383:ASP:OD2	1:B:385:TYR:HB3	2.04	0.56
1:C:382:GLN:H	1:C:382:GLN:CD	2.13	0.56
1:D:318:ARG:HD3	1:D:364:TRP:O	2.04	0.56
1:D:141:ILE:HD12	1:D:195:TRP:CZ2	2.40	0.56
1:D:295:ASP:HB2	1:D:314:ARG:HH11	1.69	0.56
1:B:192:ASP:OD1	1:B:194:LYS:HG2	2.04	0.56
1:B:236:ASN:HB3	1:B:239:HIS:CD2	2.41	0.56
1:C:240:ARG:HG2	1:C:240:ARG:HH11	1.70	0.56
1:F:259:LEU:HD22	1:F:334:LEU:HD12	1.86	0.56
1:E:282:GLY:HA2	1:E:285:HIS:CE1	2.41	0.56
1:F:171:ARG:HB2	1:F:222:PHE:HB2	1.88	0.56
1:F:248:PRO:HG2	1:F:291:ALA:HB2	1.88	0.56
1:C:47:GLU:CD	1:C:47:GLU:H	2.13	0.56
1:A:90:ASP:HB2	1:A:110:LYS:NZ	2.22	0.55
1:B:47:GLU:CD	1:B:48:MSE:HE2	2.30	0.55
1:B:235:ASP:C	1:B:237:PRO:HD3	2.32	0.55
1:D:247:THR:HG21	2:D:538:HOH:O	2.07	0.55
1:F:200:LEU:HG	1:F:261:LEU:HD21	1.89	0.55
1:B:223:ASP:OD2	1:B:227:ASN:HB2	2.06	0.55
1:D:337:ASP:OD2	1:D:339:GLN:HG2	2.07	0.55
1:A:389:HIS:HA	1:A:393:ILE:CG1	2.36	0.54
1:B:316:ARG:HG3	1:B:371:ASN:OD1	2.06	0.54
1:D:198:ARG:O	1:D:202:ILE:HG12	2.07	0.54
1:A:318:ARG:NH2	1:A:383:ASP:O	2.40	0.54

Continued on next page...

Continued from previous page...

Atom-1	Atom-2	Interatomic distance (Å)	Clash overlap (Å)
1:B:53:TRP:HB3	1:B:114:GLN:HG2	1.88	0.54
1:D:233:ASN:O	1:D:244:TYR:HB2	2.07	0.54
1:B:141:ILE:HD12	1:B:195:TRP:CZ2	2.42	0.54
1:F:322:VAL:HA	1:F:325:MSE:HE3	1.88	0.53
1:A:252:ILE:HD13	1:A:324:ALA:HA	1.91	0.53
1:C:368:ASP:HB3	1:C:370:ASP:H	1.74	0.53
1:D:45:LYS:HE3	1:D:47:GLU:OE2	2.09	0.53
1:D:316:ARG:HG3	1:D:371:ASN:OD1	2.07	0.53
1:C:152:GLU:HG2	1:C:153:GLU:H	1.73	0.53
1:E:403:ALA:HB3	1:E:404:PRO:HD3	1.89	0.53
1:A:223:ASP:OD2	1:A:227:ASN:HB2	2.09	0.53
1:C:319:TRP:CG	1:C:320:PRO:HD3	2.43	0.53
1:B:41:LYS:HB2	1:B:43:GLN:OE1	2.08	0.53
1:A:152:GLU:CD	1:A:152:GLU:H	2.17	0.53
1:B:389:HIS:HA	1:B:393:ILE:CG1	2.39	0.53
1:D:119:LEU:HD11	1:D:141:ILE:HD13	1.91	0.53
1:E:198:ARG:O	1:E:202:ILE:HG12	2.08	0.53
1:A:293:ALA:HB2	1:A:298:ASP:HA	1.91	0.53
1:A:71:PRO:HB3	1:C:348:TRP:HB3	1.90	0.53
1:B:29:ALA:HB2	1:B:38:LEU:HG	1.91	0.53
1:E:176:ASN:ND2	1:E:202:ILE:HD12	2.20	0.53
1:E:318:ARG:HD2	1:E:363:TRP:HB2	1.90	0.53
1:C:147:TYR:O	1:C:157:LEU:HD12	2.09	0.52
1:D:313:VAL:HA	2:D:498:HOH:O	2.10	0.52
1:D:384:ILE:N	1:D:384:ILE:HD13	2.23	0.52
1:F:140:THR:O	1:F:144:ILE:HG12	2.09	0.52
1:A:393:ILE:HB	1:A:394:PRO:HD3	1.92	0.52
1:D:93:TYR:CG	1:D:163:ALA:HA	2.44	0.52
1:E:235:ASP:C	1:E:236:ASN:HD22	2.17	0.52
1:C:100:VAL:HA	1:C:106:VAL:HG23	1.92	0.52
1:D:205:VAL:O	1:D:209:ASP:HB3	2.10	0.52
1:A:403:ALA:HB3	1:A:404:PRO:HD3	1.90	0.52
1:D:40:ASN:HA	1:D:381:LYS:HD2	1.92	0.52
1:D:295:ASP:HB2	1:D:314:ARG:NH1	2.25	0.52
1:E:236:ASN:HB3	1:E:239:HIS:ND1	2.24	0.52
1:C:223:ASP:OD2	1:C:225:GLN:HG2	2.10	0.52
1:D:57:ARG:O	1:D:61:VAL:HG23	2.10	0.52
1:D:3:LEU:C	1:D:345:GLN:HE22	2.18	0.51
1:B:134:ARG:NH1	2:B:498:HOH:O	2.43	0.51
1:E:323:GLU:OE2	1:E:389:HIS:HD2	1.92	0.51
1:B:22:ILE:HG12	1:B:387:LEU:HD13	1.92	0.51

Continued on next page...

Continued from previous page...

Atom-1	Atom-2	Interatomic distance (Å)	Clash overlap (Å)
1:B:171:ARG:HB2	1:B:222:PHE:HB2	1.91	0.51
1:C:274:ALA:O	1:C:278:GLU:HG3	2.10	0.51
1:A:304:VAL:HG12	1:A:306:ASP:O	2.11	0.51
1:D:368:ASP:OD2	1:D:372:LYS:HB2	2.10	0.51
1:F:37:TRP:CZ2	1:F:382:GLN:HG2	2.45	0.51
1:D:3:LEU:HD12	1:D:4:LYS:HG3	1.93	0.51
1:E:24:ASN:O	1:E:27:LYS:HG2	2.11	0.51
1:C:187:TYR:OH	1:E:191:HIS:HD2	1.94	0.51
1:E:240:ARG:HH11	1:E:240:ARG:HG2	1.75	0.51
1:C:237:PRO:C	1:C:239:HIS:H	2.19	0.50
1:E:339:GLN:HA	1:E:342:GLU:OE1	2.11	0.50
1:C:91:LYS:H	1:C:91:LYS:HD2	1.75	0.50
1:D:248:PRO:HG2	1:D:291:ALA:HB2	1.92	0.50
1:C:141:ILE:HD12	1:C:195:TRP:CZ2	2.46	0.50
1:D:295:ASP:OD2	1:D:314:ARG:HD2	2.12	0.50
1:D:53:TRP:HH2	1:D:382:GLN:NE2	2.09	0.50
1:D:321:ILE:HG12	1:D:325:MSE:HE2	1.93	0.50
1:A:39:GLY:HA3	1:A:43:GLN:HE22	1.74	0.50
1:B:160:TRP:CE2	1:B:167:THR:HB	2.47	0.50
1:F:357:ASP:OD2	1:F:360:ASN:HB2	2.11	0.50
1:A:96:TRP:H	1:A:115:HIS:CE1	2.30	0.49
1:C:200:LEU:HD21	1:C:276:LEU:HD11	1.93	0.49
1:F:3:LEU:C	1:F:345:GLN:HE22	2.20	0.49
1:C:150:SER:HB3	1:C:153:GLU:HB2	1.95	0.49
1:E:236:ASN:N	1:E:237:PRO:HD3	2.26	0.49
1:E:252:ILE:HD13	1:E:324:ALA:HA	1.93	0.49
1:F:111:GLN:O	1:F:115:HIS:HD2	1.95	0.49
1:A:177:MSE:HB2	1:A:254:TRP:CZ2	2.48	0.49
1:D:295:ASP:CB	1:D:314:ARG:HH11	2.24	0.49
1:E:285:HIS:CD2	1:E:286:ALA:N	2.80	0.49
1:A:389:HIS:HA	1:A:393:ILE:HG13	1.95	0.49
1:B:177:MSE:HB2	1:B:254:TRP:CZ2	2.48	0.49
1:C:169:ASP:HB3	2:C:495:HOH:O	2.13	0.49
1:D:240:ARG:HG3	1:D:240:ARG:NH1	2.28	0.49
1:D:357:ASP:OD2	1:D:360:ASN:HB2	2.13	0.49
1:B:3:LEU:HD23	1:B:4:LYS:HG3	1.96	0.48
1:E:52:LEU:HB3	1:E:114:GLN:OE1	2.12	0.48
1:A:69:GLY:HA2	1:C:5:TRP:NE1	2.29	0.48
1:B:365:GLN:HE22	1:B:382:GLN:NE2	2.11	0.48
1:B:403:ALA:HB3	1:B:404:PRO:HD3	1.94	0.48
1:B:29:ALA:HA	1:B:44:ILE:CD1	2.42	0.48

Continued on next page...

Continued from previous page...

Atom-1	Atom-2	Interatomic distance (Å)	Clash overlap (Å)
1:D:34:GLY:O	1:D:79:HIS:HE1	1.96	0.48
1:E:304:VAL:HG12	1:E:306:ASP:O	2.14	0.48
1:B:382:GLN:O	1:B:383:ASP:HB3	2.14	0.47
1:D:147:TYR:O	1:D:157:LEU:HD12	2.14	0.47
1:F:304:VAL:HG12	1:F:306:ASP:O	2.14	0.47
1:E:368:ASP:HB2	1:E:372:LYS:H	1.80	0.47
1:B:52:LEU:HD11	1:B:84:MSE:HE1	1.96	0.47
1:A:96:TRP:H	1:A:115:HIS:HE1	1.63	0.47
1:A:365:GLN:HB2	1:A:380:GLY:O	2.14	0.47
1:C:219:ASN:ND2	1:C:230:ARG:HD3	2.30	0.47
1:D:384:ILE:HD13	1:D:384:ILE:H	1.79	0.47
1:B:3:LEU:C	1:B:345:GLN:HE22	2.23	0.47
1:E:37:TRP:CE2	1:E:382:GLN:HG2	2.50	0.47
1:C:29:ALA:O	1:C:31:VAL:HG13	2.15	0.46
1:D:318:ARG:HD2	1:D:363:TRP:HB2	1.96	0.46
1:A:367:LEU:HD23	1:A:373:VAL:HA	1.98	0.46
1:B:172:GLY:HA2	1:B:220:GLU:O	2.15	0.46
1:E:60:HIS:HD2	1:E:124:SER:OG	1.97	0.46
1:E:139:TYR:O	1:E:142:GLU:HB2	2.16	0.46
1:F:34:GLY:O	1:F:79:HIS:HE1	1.98	0.46
1:C:373:VAL:HG23	1:C:373:VAL:O	2.15	0.46
1:E:383:ASP:OD1	1:E:385:TYR:HB3	2.16	0.46
1:B:96:TRP:H	1:B:115:HIS:CE1	2.34	0.46
1:B:259:LEU:HD22	1:B:334:LEU:CD1	2.44	0.46
1:C:304:VAL:HG22	1:C:309:GLY:C	2.41	0.46
1:E:146:LYS:HE3	1:E:147:TYR:OH	2.16	0.46
1:F:205:VAL:O	1:F:210:VAL:HG23	2.16	0.46
1:D:316:ARG:HG2	1:D:368:ASP:O	2.16	0.46
1:A:306:ASP:OD2	1:A:308:ASP:N	2.27	0.45
1:B:194:LYS:O	1:B:198:ARG:HG3	2.16	0.45
1:C:110:LYS:HG3	1:C:164:PHE:CZ	2.51	0.45
1:E:80:GLY:O	1:E:84:MSE:HG2	2.16	0.45
1:F:240:ARG:HE	1:F:313:VAL:HG11	1.81	0.45
1:A:292:TRP:C	1:A:294:PRO:HD3	2.42	0.45
1:A:389:HIS:HA	1:A:393:ILE:HG12	1.98	0.45
1:C:223:ASP:HB3	1:C:229:ILE:HD11	1.98	0.45
1:D:100:VAL:HG12	1:D:105:VAL:HA	1.98	0.45
1:F:52:LEU:HD11	1:F:84:MSE:HE1	1.98	0.45
1:F:248:PRO:HB3	1:F:287:THR:HG23	1.98	0.45
1:F:103:GLN:NE2	2:F:545:HOH:O	2.49	0.45
1:A:292:TRP:O	1:A:293:ALA:C	2.59	0.45

Continued on next page...

Continued from previous page...

Atom-1	Atom-2	Interatomic distance (Å)	Clash overlap (Å)
1:F:293:ALA:HB2	1:F:298:ASP:HA	1.98	0.45
1:D:158:GLU:HG2	1:D:170:TYR:HD2	1.81	0.45
1:E:152:GLU:HG2	1:E:153:GLU:N	2.32	0.45
1:E:381:LYS:HA	2:E:457:HOH:O	2.16	0.45
1:A:236:ASN:HB3	1:A:239:HIS:ND1	2.31	0.45
1:B:193:LYS:HD2	1:F:192:ASP:HB2	1.97	0.45
1:E:285:HIS:HD2	1:E:286:ALA:N	2.15	0.45
1:A:111:GLN:O	1:A:115:HIS:HD2	2.00	0.45
1:B:337:ASP:CG	1:B:339:GLN:HG2	2.42	0.45
1:B:389:HIS:HA	1:B:393:ILE:HG12	1.98	0.45
1:B:389:HIS:HA	1:B:393:ILE:HG13	1.99	0.45
1:D:19:THR:HG22	1:D:23:PHE:CE2	2.52	0.45
1:A:220:GLU:HG3	2:A:485:HOH:O	2.16	0.45
1:A:34:GLY:O	1:A:79:HIS:HE1	2.00	0.45
1:C:22:ILE:HD13	1:C:387:LEU:HD13	1.99	0.44
1:F:248:PRO:HA	1:F:251:TRP:CD2	2.52	0.44
1:F:96:TRP:H	1:F:115:HIS:HE1	1.65	0.44
1:A:259:LEU:HD22	1:A:334:LEU:CD1	2.47	0.44
1:B:122:ALA:O	1:B:126:VAL:HG23	2.18	0.44
1:C:174:ASN:HA	2:C:531:HOH:O	2.17	0.44
1:D:53:TRP:O	1:D:57:ARG:HG3	2.18	0.44
1:B:209:ASP:O	1:B:213:ASN:ND2	2.51	0.44
1:D:231:ASP:O	1:D:232:TYR:C	2.61	0.44
1:F:259:LEU:HD22	1:F:334:LEU:CD1	2.47	0.44
1:C:140:THR:O	1:C:144:ILE:HG12	2.17	0.44
1:B:273:PRO:HB2	1:B:275:TRP:CD1	2.52	0.44
1:C:18:GLU:CD	1:C:356:MSE:HE3	2.42	0.44
1:C:57:ARG:O	1:C:61:VAL:HG23	2.18	0.44
1:B:401:GLY:C	1:B:404:PRO:HD2	2.43	0.44
1:F:5:TRP:CD1	1:F:345:GLN:HE21	2.35	0.44
1:B:303:SER:OG	1:B:312:ILE:HB	2.17	0.44
1:D:119:LEU:HA	1:D:140:THR:HG21	1.99	0.43
1:B:18:GLU:CD	1:B:356:MSE:HE3	2.43	0.43
1:D:130:HIS:HA	1:D:131:PRO:HD3	1.89	0.43
1:A:321:ILE:HG12	1:A:325:MSE:HE2	2.00	0.43
1:C:155:MSE:SE	1:C:202:ILE:HD13	2.67	0.43
1:C:272:PRO:HA	1:C:273:PRO:HD3	1.92	0.43
1:D:47:GLU:H	1:D:47:GLU:HG3	1.49	0.43
1:D:52:LEU:HD11	1:D:84:MSE:HE1	2.00	0.43
1:B:34:GLY:O	1:B:79:HIS:HE1	2.01	0.43
1:E:96:TRP:H	1:E:115:HIS:CE1	2.36	0.43

Continued on next page...

Continued from previous page...

Atom-1	Atom-2	Interatomic distance (Å)	Clash overlap (Å)
1:E:357:ASP:OD2	1:E:360:ASN:HB2	2.18	0.43
1:A:135:LYS:HG3	2:A:431:HOH:O	2.17	0.43
1:B:51:HIS:HD2	2:B:471:HOH:O	2.02	0.43
1:B:248:PRO:HA	1:B:251:TRP:CD2	2.54	0.43
1:E:147:TYR:O	1:E:157:LEU:HD12	2.18	0.43
1:F:182:ALA:O	1:F:186:VAL:HG23	2.19	0.43
1:F:304:VAL:HG13	1:F:309:GLY:C	2.43	0.43
1:F:401:GLY:O	1:F:404:PRO:HG2	2.17	0.43
1:E:254:TRP:O	1:E:258:MSE:HG3	2.18	0.43
1:C:3:LEU:C	1:C:345:GLN:HE22	2.26	0.43
1:C:207:ILE:HA	1:C:211:ALA:HB3	1.98	0.43
1:F:5:TRP:CG	1:F:345:GLN:HE21	2.37	0.43
1:D:47:GLU:OE1	1:D:48:MSE:HE3	2.18	0.43
1:D:274:ALA:O	1:D:278:GLU:HG3	2.19	0.43
1:F:119:LEU:HA	1:F:140:THR:HG21	2.01	0.43
1:F:149:TRP:CZ2	1:F:198:ARG:HG2	2.54	0.43
1:A:119:LEU:HA	1:A:140:THR:HG21	2.00	0.43
1:E:236:ASN:HB3	1:E:239:HIS:CG	2.54	0.43
1:E:274:ALA:O	1:E:278:GLU:HG3	2.19	0.43
1:B:141:ILE:HD12	1:B:195:TRP:CH2	2.53	0.43
1:C:39:GLY:HA2	1:C:380:GLY:N	2.34	0.43
1:D:341:GLU:O	1:D:345:GLN:HG3	2.18	0.43
1:B:304:VAL:HG22	1:B:310:LYS:C	2.44	0.42
1:D:96:TRP:H	1:D:115:HIS:CE1	2.37	0.42
1:D:317:VAL:O	1:D:320:PRO:HD2	2.19	0.42
1:F:362:SER:OG	1:F:363:TRP:N	2.47	0.42
1:A:232:TYR:O	1:A:233:ASN:HB2	2.19	0.42
1:B:190:THR:O	1:B:191:HIS:HB2	2.19	0.42
1:C:182:ALA:O	1:C:186:VAL:HG23	2.19	0.42
1:E:37:TRP:CD1	1:E:45:LYS:HD3	2.54	0.42
1:E:158:GLU:HG2	1:E:170:TYR:HD2	1.83	0.42
1:E:319:TRP:CG	1:E:320:PRO:HD3	2.54	0.42
1:A:372:LYS:HB3	1:A:372:LYS:NZ	2.35	0.42
1:D:52:LEU:HB3	1:D:114:GLN:OE1	2.19	0.42
1:D:353:LYS:HD3	1:D:354:TYR:CE1	2.55	0.42
1:A:142:GLU:O	1:A:146:LYS:HB2	2.18	0.42
1:D:69:GLY:HA2	1:F:5:TRP:CE2	2.54	0.42
1:E:98:ALA:HB3	1:E:107:ASP:CG	2.44	0.42
1:F:223:ASP:HB3	1:F:229:ILE:HD11	2.00	0.42
1:C:236:ASN:N	1:C:236:ASN:HD22	2.16	0.42
1:C:341:GLU:O	1:C:345:GLN:HG3	2.19	0.42

Continued on next page...

Continued from previous page...

Atom-1	Atom-2	Interatomic distance (Å)	Clash overlap (Å)
1:D:3:LEU:CD1	1:D:4:LYS:HG3	2.49	0.42
1:F:53:TRP:HB3	1:F:114:GLN:HG2	2.01	0.42
1:F:316:ARG:HG3	1:F:371:ASN:OD1	2.19	0.42
1:E:382:GLN:NE2	1:E:382:GLN:C	2.77	0.42
1:F:96:TRP:H	1:F:115:HIS:CE1	2.37	0.42
1:C:119:LEU:HA	1:C:140:THR:HG21	2.00	0.42
1:E:177:MSE:HB2	1:E:254:TRP:CZ2	2.54	0.42
1:E:321:ILE:HG12	1:E:325:MSE:HE2	2.02	0.42
1:C:149:TRP:HZ3	1:C:202:ILE:HD11	1.84	0.42
1:B:140:THR:O	1:B:144:ILE:HG12	2.19	0.42
1:D:248:PRO:HA	1:D:251:TRP:CD2	2.54	0.42
1:B:26:GLY:HA3	1:B:384:ILE:HD13	2.02	0.42
1:E:51:HIS:HB3	1:E:53:TRP:CD1	2.55	0.42
1:E:38:LEU:HD22	1:E:42:GLY:O	2.20	0.41
1:E:325:MSE:HE1	1:E:351:CYS:SG	2.60	0.41
1:F:39:GLY:HA2	1:F:380:GLY:N	2.35	0.41
1:B:318:ARG:HD2	1:B:363:TRP:HB2	2.01	0.41
1:D:39:GLY:HA3	1:D:43:GLN:HE22	1.81	0.41
1:E:5:TRP:NE1	1:F:69:GLY:HA2	2.36	0.41
1:E:115:HIS:O	1:E:118:ALA:HB3	2.19	0.41
1:E:258:MSE:HE2	1:E:283:LEU:HD12	2.02	0.41
1:D:58:MSE:SE	1:D:384:ILE:CD1	3.11	0.41
1:F:122:ALA:O	1:F:126:VAL:HG23	2.21	0.41
1:D:68:MSE:HE3	1:D:411:LEU:HD21	2.03	0.41
1:A:5:TRP:NE1	1:B:69:GLY:HA2	2.35	0.41
1:A:194:LYS:O	1:A:198:ARG:HG3	2.21	0.41
1:A:198:ARG:O	1:A:202:ILE:HG13	2.21	0.41
1:D:16:GLU:HB2	1:D:395:ARG:NH1	2.35	0.41
1:A:248:PRO:HA	1:A:251:TRP:CD2	2.55	0.41
1:C:158:GLU:HG2	1:C:170:TYR:HD2	1.86	0.41
1:D:319:TRP:CG	1:D:320:PRO:HD3	2.55	0.41
1:A:51:HIS:HD2	2:A:520:HOH:O	2.04	0.41
1:E:272:PRO:HA	1:E:273:PRO:HD3	1.96	0.41
1:A:248:PRO:HG2	1:A:291:ALA:HB2	2.02	0.41
1:A:374:THR:HG22	1:A:375:THR:N	2.35	0.41
1:C:236:ASN:HB3	1:C:239:HIS:CE1	2.56	0.41
1:C:240:ARG:HG2	1:C:240:ARG:NH1	2.33	0.41
1:C:253:GLU:HG3	1:C:323:GLU:OE1	2.21	0.41
1:C:331:LEU:HD13	1:C:340:TYR:CE2	2.56	0.41
1:C:393:ILE:HG23	2:C:464:HOH:O	2.21	0.41
1:D:18:GLU:CD	1:D:356:MSE:HE3	2.46	0.41

Continued on next page...

Continued from previous page...

Atom-1	Atom-2	Interatomic distance (Å)	Clash overlap (Å)
1:D:272:PRO:HA	1:D:273:PRO:HD3	1.98	0.41
1:D:384:ILE:HD13	2:D:434:HOH:O	2.21	0.41
1:F:259:LEU:HD23	1:F:259:LEU:HA	1.88	0.41
1:F:319:TRP:CG	1:F:320:PRO:HD3	2.56	0.41
1:A:16:GLU:HB2	1:A:395:ARG:NH1	2.36	0.41
1:A:40:ASN:HA	1:A:381:LYS:HD2	2.02	0.41
1:B:252:ILE:HD13	1:B:324:ALA:HA	2.02	0.41
1:C:317:VAL:O	1:C:320:PRO:HD2	2.21	0.41
1:D:290:ASP:HB3	1:D:304:VAL:HG21	2.03	0.41
1:B:39:GLY:O	1:B:381:LYS:HB2	2.21	0.40
1:B:410:LEU:HD22	1:B:413:ILE:HD12	2.03	0.40
1:C:110:LYS:HA	2:C:462:HOH:O	2.20	0.40
1:A:27:LYS:HB3	1:A:27:LYS:HE2	1.90	0.40
1:B:108:ALA:HB1	1:B:162:GLU:HG3	2.03	0.40
1:B:119:LEU:HA	1:B:140:THR:HG21	2.01	0.40
1:B:152:GLU:H	1:B:152:GLU:CD	2.29	0.40
1:D:156:CYS:H	1:D:176:ASN:ND2	2.05	0.40
1:E:7:ASN:ND2	2:E:430:HOH:O	2.49	0.40
1:E:51:HIS:CD2	1:E:53:TRP:HE1	2.38	0.40
1:A:5:TRP:CD1	1:B:69:GLY:HA2	2.55	0.40
1:C:209:ASP:O	1:C:213:ASN:ND2	2.55	0.40
1:C:288:ILE:HD13	1:C:343:TRP:CE2	2.55	0.40
1:E:240:ARG:HG2	1:E:240:ARG:NH1	2.35	0.40
1:C:37:TRP:CZ2	1:C:48:MSE:HE3	2.56	0.40
1:C:287:THR:O	1:C:291:ALA:HB3	2.21	0.40
1:D:292:TRP:O	1:D:293:ALA:C	2.64	0.40
1:F:403:ALA:N	1:F:404:PRO:HD2	2.37	0.40
1:A:69:GLY:HA2	1:C:5:TRP:CE2	2.57	0.40
1:A:90:ASP:HB2	1:A:110:LYS:HZ2	1.86	0.40
1:A:362:SER:OG	1:A:363:TRP:N	2.54	0.40
1:C:34:GLY:O	1:C:79:HIS:HE1	2.04	0.40
1:E:16:GLU:HB2	1:E:395:ARG:NH1	2.36	0.40
1:E:90:ASP:HB2	1:E:110:LYS:NZ	2.37	0.40
1:F:123:ALA:O	1:F:126:VAL:HB	2.21	0.40

There are no symmetry-related clashes.

5.3 Torsion angles [i](#)

5.3.1 Protein backbone [i](#)

In the following table, the Percentiles column shows the percent Ramachandran outliers of the chain as a percentile score with respect to all X-ray entries followed by that with respect to entries of similar resolution.

The Analysed column shows the number of residues for which the backbone conformation was analysed, and the total number of residues.

Mol	Chain	Analysed	Favoured	Allowed	Outliers	Percentiles	
1	A	404/425 (95%)	386 (96%)	18 (4%)	0	100	100
1	B	404/425 (95%)	378 (94%)	22 (5%)	4 (1%)	12	8
1	C	404/425 (95%)	380 (94%)	21 (5%)	3 (1%)	18	13
1	D	404/425 (95%)	387 (96%)	16 (4%)	1 (0%)	43	44
1	E	404/425 (95%)	385 (95%)	18 (4%)	1 (0%)	43	44
1	F	404/425 (95%)	389 (96%)	14 (4%)	1 (0%)	43	44
All	All	2424/2550 (95%)	2305 (95%)	109 (4%)	10 (0%)	30	26

All (10) Ramachandran outliers are listed below:

Mol	Chain	Res	Type
1	E	210	VAL
1	C	238	ALA
1	B	46	GLU
1	B	402	LEU
1	C	237	PRO
1	C	402	LEU
1	F	402	LEU
1	B	237	PRO
1	D	402	LEU
1	B	312	ILE

5.3.2 Protein sidechains [i](#)

In the following table, the Percentiles column shows the percent sidechain outliers of the chain as a percentile score with respect to all X-ray entries followed by that with respect to entries of similar resolution.

The Analysed column shows the number of residues for which the sidechain conformation was analysed, and the total number of residues.

Mol	Chain	Analysed	Rotameric	Outliers	Percentiles	
1	A	334/339 (98%)	327 (98%)	7 (2%)	47	52
1	B	334/339 (98%)	330 (99%)	4 (1%)	63	70
1	C	334/339 (98%)	329 (98%)	5 (2%)	57	64
1	D	334/339 (98%)	324 (97%)	10 (3%)	36	38
1	E	334/339 (98%)	326 (98%)	8 (2%)	43	47
1	F	334/339 (98%)	328 (98%)	6 (2%)	51	58
All	All	2004/2034 (98%)	1964 (98%)	40 (2%)	48	54

All (40) residues with a non-rotameric sidechain are listed below:

Mol	Chain	Res	Type
1	A	3	LEU
1	A	47	GLU
1	A	225	GLN
1	A	261	LEU
1	A	306	ASP
1	A	336	ASP
1	A	385	TYR
1	B	47	GLU
1	B	75	ASP
1	B	247	THR
1	B	304	VAL
1	C	43	GLN
1	C	47	GLU
1	C	247	THR
1	C	266	GLU
1	C	385	TYR
1	D	47	GLU
1	D	48	MSE
1	D	75	ASP
1	D	135	LYS
1	D	261	LEU
1	D	304	VAL
1	D	308	ASP
1	D	382	GLN
1	D	384	ILE
1	D	385	TYR
1	E	47	GLU
1	E	103	GLN
1	E	233	ASN
1	E	285	HIS

Continued on next page...

Continued from previous page...

Mol	Chain	Res	Type
1	E	294	PRO
1	E	381	LYS
1	E	382	GLN
1	E	385	TYR
1	F	28	ASN
1	F	103	GLN
1	F	152	GLU
1	F	247	THR
1	F	382	GLN
1	F	385	TYR

Sometimes sidechains can be flipped to improve hydrogen bonding and reduce clashes. All (84) such sidechains are listed below:

Mol	Chain	Res	Type
1	A	28	ASN
1	A	40	ASN
1	A	51	HIS
1	A	85	ASN
1	A	103	GLN
1	A	115	HIS
1	A	154	GLN
1	A	176	ASN
1	A	191	HIS
1	A	219	ASN
1	A	233	ASN
1	A	236	ASN
1	B	51	HIS
1	B	79	HIS
1	B	85	ASN
1	B	115	HIS
1	B	176	ASN
1	B	219	ASN
1	B	225	GLN
1	B	227	ASN
1	B	236	ASN
1	B	239	HIS
1	B	250	HIS
1	B	345	GLN
1	B	365	GLN
1	C	28	ASN
1	C	40	ASN
1	C	51	HIS

Continued on next page...

Continued from previous page...

Mol	Chain	Res	Type
1	C	103	GLN
1	C	115	HIS
1	C	154	GLN
1	C	176	ASN
1	C	213	ASN
1	C	219	ASN
1	C	227	ASN
1	C	236	ASN
1	C	262	HIS
1	C	345	GLN
1	D	40	ASN
1	D	51	HIS
1	D	79	HIS
1	D	85	ASN
1	D	115	HIS
1	D	154	GLN
1	D	176	ASN
1	D	219	ASN
1	D	227	ASN
1	D	236	ASN
1	D	250	HIS
1	D	285	HIS
1	D	345	GLN
1	D	365	GLN
1	E	7	ASN
1	E	28	ASN
1	E	40	ASN
1	E	51	HIS
1	E	60	HIS
1	E	111	GLN
1	E	115	HIS
1	E	176	ASN
1	E	191	HIS
1	E	219	ASN
1	E	225	GLN
1	E	233	ASN
1	E	236	ASN
1	E	262	HIS
1	E	285	HIS
1	E	360	ASN
1	E	382	GLN
1	E	389	HIS

Continued on next page...

Continued from previous page...

Mol	Chain	Res	Type
1	F	51	HIS
1	F	79	HIS
1	F	115	HIS
1	F	154	GLN
1	F	176	ASN
1	F	219	ASN
1	F	227	ASN
1	F	236	ASN
1	F	239	HIS
1	F	250	HIS
1	F	339	GLN
1	F	345	GLN
1	F	365	GLN
1	F	382	GLN

5.3.3 RNA [i](#)

There are no RNA molecules in this entry.

5.4 Non-standard residues in protein, DNA, RNA chains [i](#)

There are no non-standard protein/DNA/RNA residues in this entry.

5.5 Carbohydrates [i](#)

There are no oligosaccharides in this entry.

5.6 Ligand geometry [i](#)

There are no ligands in this entry.

5.7 Other polymers [i](#)

There are no such residues in this entry.

5.8 Polymer linkage issues [i](#)

There are no chain breaks in this entry.

6 Fit of model and data

6.1 Protein, DNA and RNA chains

In the following table, the column labelled ‘#RSRZ > 2’ contains the number (and percentage) of RSRZ outliers, followed by percent RSRZ outliers for the chain as percentile scores relative to all X-ray entries and entries of similar resolution. The OWAB column contains the minimum, median, 95th percentile and maximum values of the occupancy-weighted average B-factor per residue. The column labelled ‘Q < 0.9’ lists the number of (and percentage) of residues with an average occupancy less than 0.9.

Mol	Chain	Analysed	<RSRZ>	#RSRZ>2	OWAB(Å ²)	Q<0.9
1	A	399/425 (93%)	0.08	8 (2%) 65 69	15, 32, 46, 55	0
1	B	399/425 (93%)	0.36	13 (3%) 49 53	19, 35, 48, 56	0
1	C	399/425 (93%)	0.40	18 (4%) 38 43	18, 35, 49, 55	0
1	D	399/425 (93%)	0.26	15 (3%) 44 49	18, 34, 46, 55	0
1	E	399/425 (93%)	0.46	21 (5%) 32 36	19, 36, 50, 57	0
1	F	399/425 (93%)	0.10	8 (2%) 65 69	16, 32, 46, 56	0
All	All	2394/2550 (93%)	0.28	83 (3%) 47 51	15, 34, 48, 57	0

All (83) RSRZ outliers are listed below:

Mol	Chain	Res	Type	RSRZ
1	F	375	THR	6.2
1	E	380	GLY	4.6
1	E	375	THR	4.6
1	C	374	THR	4.4
1	C	238	ALA	4.1
1	C	3	LEU	4.1
1	E	285	HIS	4.1
1	D	237	PRO	4.0
1	F	3	LEU	3.8
1	B	3	LEU	3.8
1	B	238	ALA	3.6
1	C	243	ALA	3.5
1	D	239	HIS	3.5
1	C	241	PHE	3.5
1	D	238	ALA	3.4
1	E	3	LEU	3.4
1	C	375	THR	3.2
1	E	374	THR	3.2
1	B	375	THR	3.2

Continued on next page...

Continued from previous page...

Mol	Chain	Res	Type	RSRZ
1	E	94	GLY	3.2
1	D	3	LEU	3.2
1	C	237	PRO	3.1
1	B	415	ALA	2.9
1	E	229	ILE	2.9
1	F	209	ASP	2.9
1	C	380	GLY	2.9
1	F	374	THR	2.8
1	A	3	LEU	2.8
1	D	308	ASP	2.7
1	D	368	ASP	2.7
1	C	91	LYS	2.7
1	E	202	ILE	2.6
1	E	239	HIS	2.6
1	E	415	ALA	2.6
1	A	380	GLY	2.6
1	D	375	THR	2.6
1	B	237	PRO	2.6
1	A	375	THR	2.6
1	B	231	ASP	2.5
1	F	239	HIS	2.5
1	A	306	ASP	2.4
1	B	380	GLY	2.4
1	A	209	ASP	2.4
1	E	368	ASP	2.4
1	B	374	THR	2.4
1	B	29	ALA	2.4
1	D	415	ALA	2.4
1	D	224	SER	2.4
1	C	415	ALA	2.4
1	F	241	PHE	2.4
1	D	304	VAL	2.3
1	F	380	GLY	2.3
1	D	240	ARG	2.3
1	C	239	HIS	2.3
1	A	304	VAL	2.3
1	E	304	VAL	2.3
1	E	166	GLN	2.3
1	A	415	ALA	2.3
1	E	108	ALA	2.3
1	C	141	ILE	2.2
1	E	237	PRO	2.2

Continued on next page...

Continued from previous page...

Mol	Chain	Res	Type	RSRZ
1	D	306	ASP	2.2
1	F	237	PRO	2.2
1	E	163	ALA	2.2
1	E	170	TYR	2.2
1	C	202	ILE	2.2
1	D	241	PHE	2.1
1	E	382	GLN	2.1
1	B	105	VAL	2.1
1	C	231	ASP	2.1
1	C	164	PHE	2.1
1	E	241	PHE	2.1
1	C	236	ASN	2.1
1	B	166	GLN	2.1
1	B	239	HIS	2.1
1	D	247	THR	2.1
1	E	87	ALA	2.1
1	B	235	ASP	2.0
1	C	336	ASP	2.0
1	D	374	THR	2.0
1	E	93	TYR	2.0
1	C	368	ASP	2.0
1	A	237	PRO	2.0

6.2 Non-standard residues in protein, DNA, RNA chains [\(i\)](#)

There are no non-standard protein/DNA/RNA residues in this entry.

6.3 Carbohydrates [\(i\)](#)

There are no oligosaccharides in this entry.

6.4 Ligands [\(i\)](#)

There are no ligands in this entry.

6.5 Other polymers [\(i\)](#)

There are no such residues in this entry.