



wwPDB EM Validation Summary Report ⓘ

Mar 20, 2026 – 04:41 PM UTC

PDB ID : 6CGR / pdb_00006cgr
EMDB ID : EMD-7472
Title : CryoEM structure of herpes simplex virus 1 capsid with associated tegument protein complexes.
Authors : Dai, X.H.; Zhou, Z.H.
Deposited on : 2018-02-20
Resolution : 4.20 Å(reported)

This is a wwPDB EM Validation Summary Report for a publicly released PDB entry.

We welcome your comments at validation@mail.wwpdb.org

A user guide is available at

<https://www.wwpdb.org/validation/2017/EMValidationReportHelp>

with specific help available everywhere you see the ⓘ symbol.

The types of validation reports are described at

<http://www.wwpdb.org/validation/2017/FAQs#types>.

The following versions of software and data (see [references ⓘ](#)) were used in the production of this report:

EMDB validation analysis : 0.0.1.dev132
MolProbity : 4-5-2 with Phenix2.0
Percentile statistics : 20250101.v01 (using entries in the PDB archive January 1st 2025)
EM percentile statistics : 202505.v01 (Using data in the EMDB archive up until May 2025)
MapQ : 1.9.13
Ideal geometry (proteins) : Engh & Huber (2001)
Ideal geometry (DNA, RNA) : Parkinson et al. (1996)
Validation Pipeline (wwPDB-VP) : 2.49

1 Overall quality at a glance i

The following experimental techniques were used to determine the structure:
ELECTRON MICROSCOPY

The reported resolution of this entry is 4.20 Å.

Percentile scores (ranging between 0-100) for global validation metrics of the entry are shown in the following graphic. The table shows the number of entries on which the scores are based.

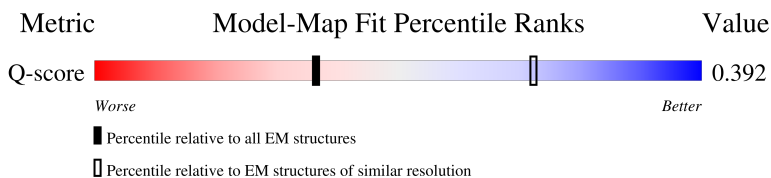
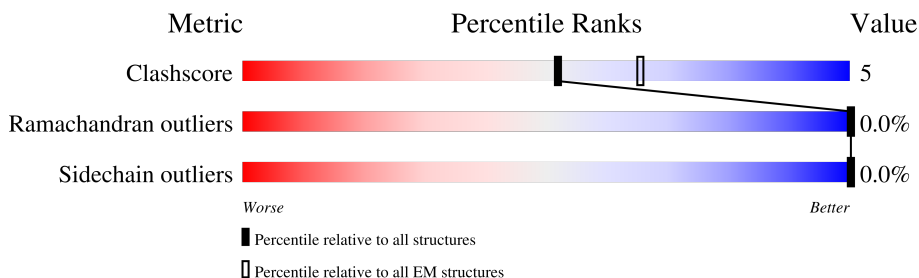

Metric	Whole archive (#Entries)	EM structures (#Entries)	Similar EM resolution (#Entries, resolution range(Å))
Clashscore	229148	23984	-
Ramachandran outliers	224038	23583	-
Sidechain outliers	223484	23102	-
Q-score	-	25397	5410 (3.70 - 4.70)

The table below summarises the geometric issues observed across the polymeric chains and their fit to the map. The red, orange, yellow and green segments of the bar indicate the fraction of residues that contain outliers for ≥ 3 , 2, 1 and 0 types of geometric quality criteria respectively. A grey segment represents the fraction of residues that are not modelled. The numeric value for each fraction is indicated below the corresponding segment, with a dot representing fractions $\leq 5\%$. The upper red bar (where present) indicates the fraction of residues that have poor fit to the EM map (all-atom inclusion $< 40\%$). The numeric value is given above the bar.

Mol	Chain	Length	Quality of chain
1	4	1374	<div style="display: flex; align-items: center;"> <div style="width: 49%; height: 10px; background-color: red; margin-right: 5px;"></div> <div style="width: 78%; height: 10px; background-color: green; margin-right: 5px;"></div> <div style="width: 14%; height: 10px; background-color: yellow; margin-right: 5px;"></div> <div style="width: 8%; height: 10px; background-color: grey;"></div> </div>
1	A	1374	<div style="display: flex; align-items: center;"> <div style="width: 14%; height: 10px; background-color: red; margin-right: 5px;"></div> <div style="width: 84%; height: 10px; background-color: green; margin-right: 5px;"></div> <div style="width: 16%; height: 10px; background-color: yellow; margin-right: 5px;"></div> <div style="width: 5%; height: 10px; background-color: grey;"></div> </div>
1	B	1374	<div style="display: flex; align-items: center;"> <div style="width: 12%; height: 10px; background-color: red; margin-right: 5px;"></div> <div style="width: 85%; height: 10px; background-color: green; margin-right: 5px;"></div> <div style="width: 14%; height: 10px; background-color: yellow; margin-right: 5px;"></div> <div style="width: 5%; height: 10px; background-color: grey;"></div> </div>
1	C	1374	<div style="display: flex; align-items: center;"> <div style="width: 15%; height: 10px; background-color: red; margin-right: 5px;"></div> <div style="width: 85%; height: 10px; background-color: green; margin-right: 5px;"></div> <div style="width: 14%; height: 10px; background-color: yellow; margin-right: 5px;"></div> <div style="width: 5%; height: 10px; background-color: grey;"></div> </div>

Continued on next page...

Continued from previous page...

Mol	Chain	Length	Quality of chain
1	D	1374	14% 83% 16%
1	E	1374	16% 83% 17%
1	F	1374	13% 83% 16%
1	M	1374	12% 83% 16%
1	N	1374	12% 84% 15%
1	O	1374	13% 84% 15%
1	S	1374	21% 82% 17%
1	T	1374	21% 84% 15%
1	U	1374	17% 82% 17%
1	V	1374	18% 83% 16%
1	W	1374	17% 84% 15%
1	X	1374	21% 82% 16%
2	0	112	55% 85% 5% 10%
2	1	112	48% 84% 6% 10%
2	2	112	54% 86% 10%
2	3	112	53% 86% 10%
2	G	112	47% 87% 10%
2	H	112	40% 83% 7% 10%
2	I	112	46% 85% 5% 10%
2	J	112	38% 85% 5% 10%
2	K	112	48% 84% 6% 10%
2	L	112	41% 84% 6% 10%
2	P	112	36% 86% 10%
2	Q	112	39% 86% 10%
2	R	112	29% 86% 10%

Continued on next page...

Continued from previous page...

Mol	Chain	Length	Quality of chain
2	Y	112	62% 87% 10%
2	Z	112	61% 84% 6% 10%
3	5	465	21% 67% 9% 24%
3	8	465	11% 68% 9% 22%
3	b	465	17% 66% 12% 22%
3	e	465	15% 66% 10% 24%
3	h	465	14% 63% 12% 24%
4	6	318	31% 78% 9% 13%
4	7	318	32% 83% 14%
4	9	318	12% 77% 9% 14%
4	a	318	14% 83% 13%
4	c	318	14% 75% 11% 14%
4	d	318	11% 82% 14%
4	f	318	14% 72% 13% 14%
4	g	318	20% 84% 13%
4	i	318	16% 77% 10% 13%
4	j	318	11% 87% 9%
5	k	703	33% 71% 8% 22%
6	l	580	10% 15% 84%
6	m	580	9% 12% 86%
7	n	3139	99%
7	o	3139	99%

2 Entry composition [i](#)

There are 7 unique types of molecules in this entry. The entry contains 219702 atoms, of which 0 are hydrogens and 0 are deuteriums.

In the tables below, the AltConf column contains the number of residues with at least one atom in alternate conformation and the Trace column contains the number of residues modelled with at most 2 atoms.

- Molecule 1 is a protein called Major capsid protein.

Mol	Chain	Residues	Atoms					AltConf	Trace
			Total	C	N	O	S		
1	A	1362	10409	6575	1871	1909	54	0	0
1	B	1364	10423	6585	1873	1911	54	0	0
1	C	1364	10423	6585	1873	1911	54	0	0
1	D	1362	10409	6575	1871	1909	54	0	0
1	E	1366	10442	6595	1878	1915	54	0	0
1	F	1362	10409	6575	1871	1909	54	0	0
1	M	1362	10409	6575	1871	1909	54	0	0
1	N	1366	10442	6595	1878	1915	54	0	0
1	O	1364	10423	6585	1873	1911	54	0	0
1	S	1357	10365	6547	1864	1900	54	0	0
1	T	1357	10379	6553	1868	1904	54	0	0
1	U	1364	10423	6585	1873	1911	54	0	0
1	V	1362	10409	6575	1871	1909	54	0	0
1	W	1364	10423	6585	1873	1911	54	0	0
1	X	1348	10314	6516	1857	1888	53	0	0
1	4	1259	9648	6103	1726	1769	50	0	0

- Molecule 2 is a protein called Small capsomere-interacting protein.

Mol	Chain	Residues	Atoms					AltConf	Trace
2	G	101	Total	C	N	O	S	0	0
			774	488	146	137	3		
2	H	101	Total	C	N	O	S	0	0
			774	488	146	137	3		
2	I	101	Total	C	N	O	S	0	0
			774	488	146	137	3		
2	J	101	Total	C	N	O	S	0	0
			774	488	146	137	3		
2	K	101	Total	C	N	O	S	0	0
			774	488	146	137	3		
2	L	101	Total	C	N	O	S	0	0
			774	488	146	137	3		
2	P	101	Total	C	N	O	S	0	0
			774	488	146	137	3		
2	Q	101	Total	C	N	O	S	0	0
			774	488	146	137	3		
2	R	101	Total	C	N	O	S	0	0
			774	488	146	137	3		
2	Y	101	Total	C	N	O	S	0	0
			774	488	146	137	3		
2	Z	101	Total	C	N	O	S	0	0
			774	488	146	137	3		
2	0	101	Total	C	N	O	S	0	0
			774	488	146	137	3		
2	1	101	Total	C	N	O	S	0	0
			774	488	146	137	3		
2	2	101	Total	C	N	O	S	0	0
			774	488	146	137	3		
2	3	101	Total	C	N	O	S	0	0
			774	488	146	137	3		

- Molecule 3 is a protein called Triplex capsid protein 1.

Mol	Chain	Residues	Atoms					AltConf	Trace
3	5	353	Total	C	N	O	S	0	0
			2724	1708	518	481	17		
3	8	363	Total	C	N	O	S	0	0
			2786	1741	531	496	18		
3	b	363	Total	C	N	O	S	0	0
			2786	1741	531	496	18		
3	e	352	Total	C	N	O	S	0	0
			2720	1706	517	480	17		
3	h	353	Total	C	N	O	S	0	0
			2724	1708	518	481	17		

- Molecule 4 is a protein called Triplex capsid protein 2.

Mol	Chain	Residues	Atoms					AltConf	Trace
4	6	276	Total	C	N	O	S	0	0
			2116	1354	375	380	7		
4	7	308	Total	C	N	O	S	0	0
			2341	1487	415	430	9		
4	9	274	Total	C	N	O	S	0	0
			2091	1338	370	376	7		
4	a	308	Total	C	N	O	S	0	0
			2341	1487	415	430	9		
4	c	274	Total	C	N	O	S	0	0
			2091	1338	370	376	7		
4	d	308	Total	C	N	O	S	0	0
			2341	1487	415	430	9		
4	f	272	Total	C	N	O	S	0	0
			2089	1337	371	374	7		
4	g	308	Total	C	N	O	S	0	0
			2341	1487	415	430	9		
4	i	276	Total	C	N	O	S	0	0
			2116	1354	375	380	7		
4	j	308	Total	C	N	O	S	0	0
			2341	1487	415	430	9		

- Molecule 5 is a protein called Capsid vertex component 1.

Mol	Chain	Residues	Atoms					AltConf	Trace
5	k	550	Total	C	N	O	S	0	0
			4206	2674	764	747	21		

- Molecule 6 is a protein called Capsid vertex component 2.

Mol	Chain	Residues	Atoms					AltConf	Trace
6	l	94	Total	C	N	O	S	0	0
			766	486	138	138	4		
6	m	80	Total	C	N	O	S	0	0
			654	413	124	115	2		

- Molecule 7 is a protein called Large tegument protein deneddylase.

Mol	Chain	Residues	Atoms					AltConf	Trace
7	n	47	Total	C	N	O	S	0	0
			384	237	84	61	2		
7	o	47	Total	C	N	O	S	0	0
			384	237	84	61	2		

3 Residue-property plots

These plots are drawn for all protein, RNA, DNA and oligosaccharide chains in the entry. The first graphic for a chain summarises the proportions of the various outlier classes displayed in the second graphic. The second graphic shows the sequence view annotated by issues in geometry and atom inclusion in map density. Residues are color-coded according to the number of geometric quality criteria for which they contain at least one outlier: green = 0, yellow = 1, orange = 2 and red = 3 or more. A red diamond above a residue indicates a poor fit to the EM map for this residue (all-atom inclusion < 40%). Stretches of 2 or more consecutive residues without any outlier are shown as a green connector. Residues present in the sample, but not in the model, are shown in grey.

- Molecule 1: Major capsid protein

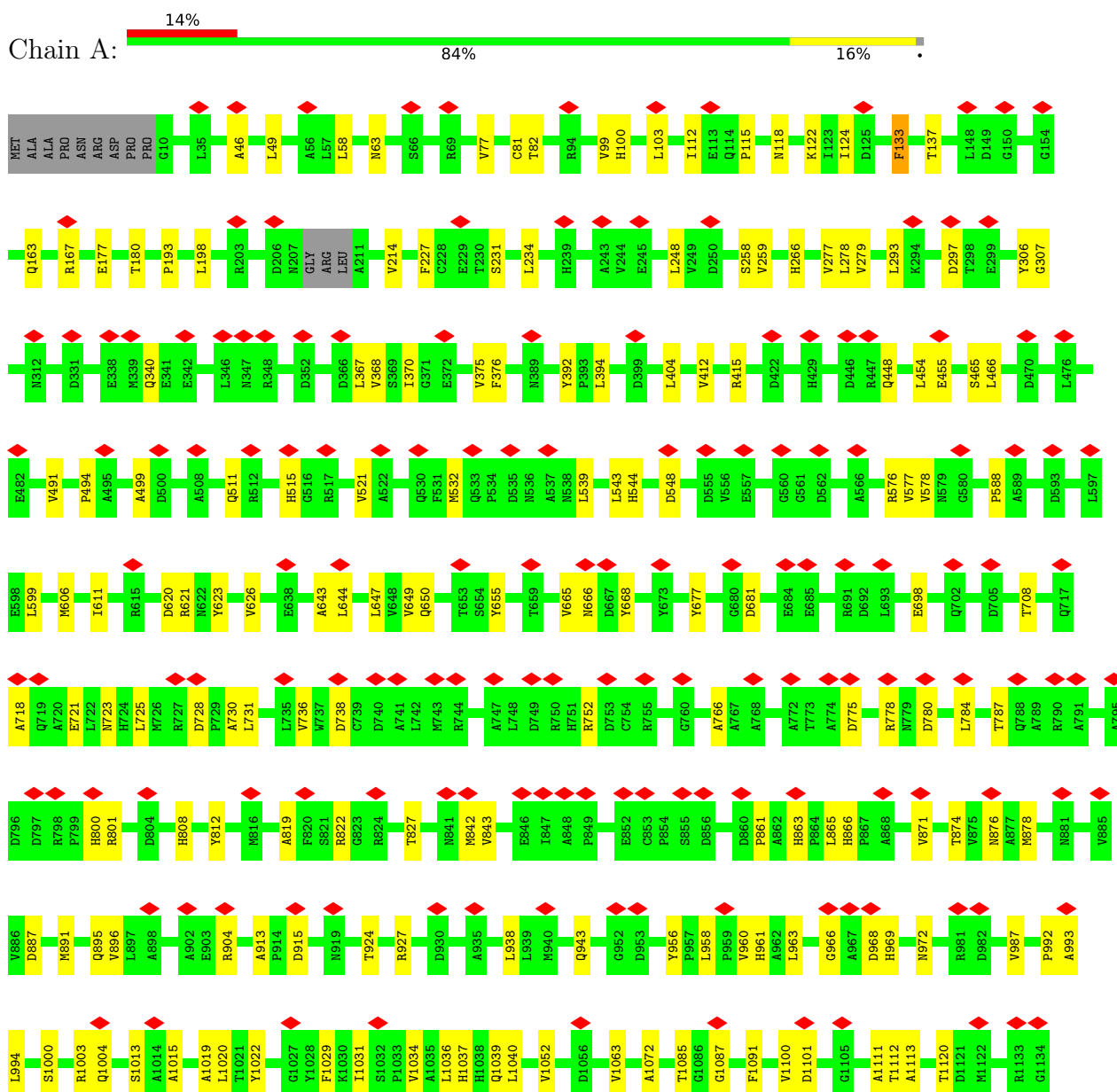

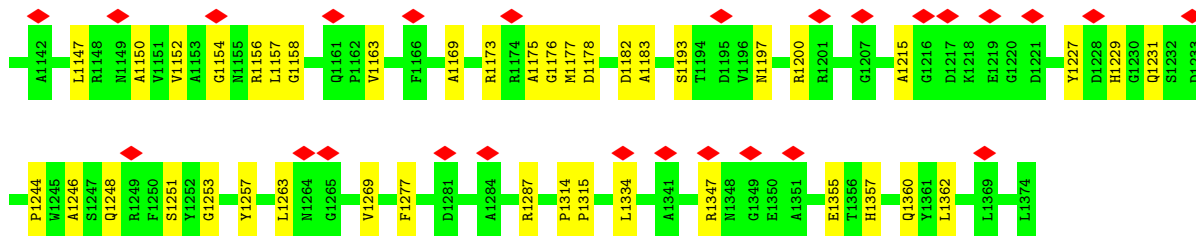

• Molecule 1: Major capsid protein

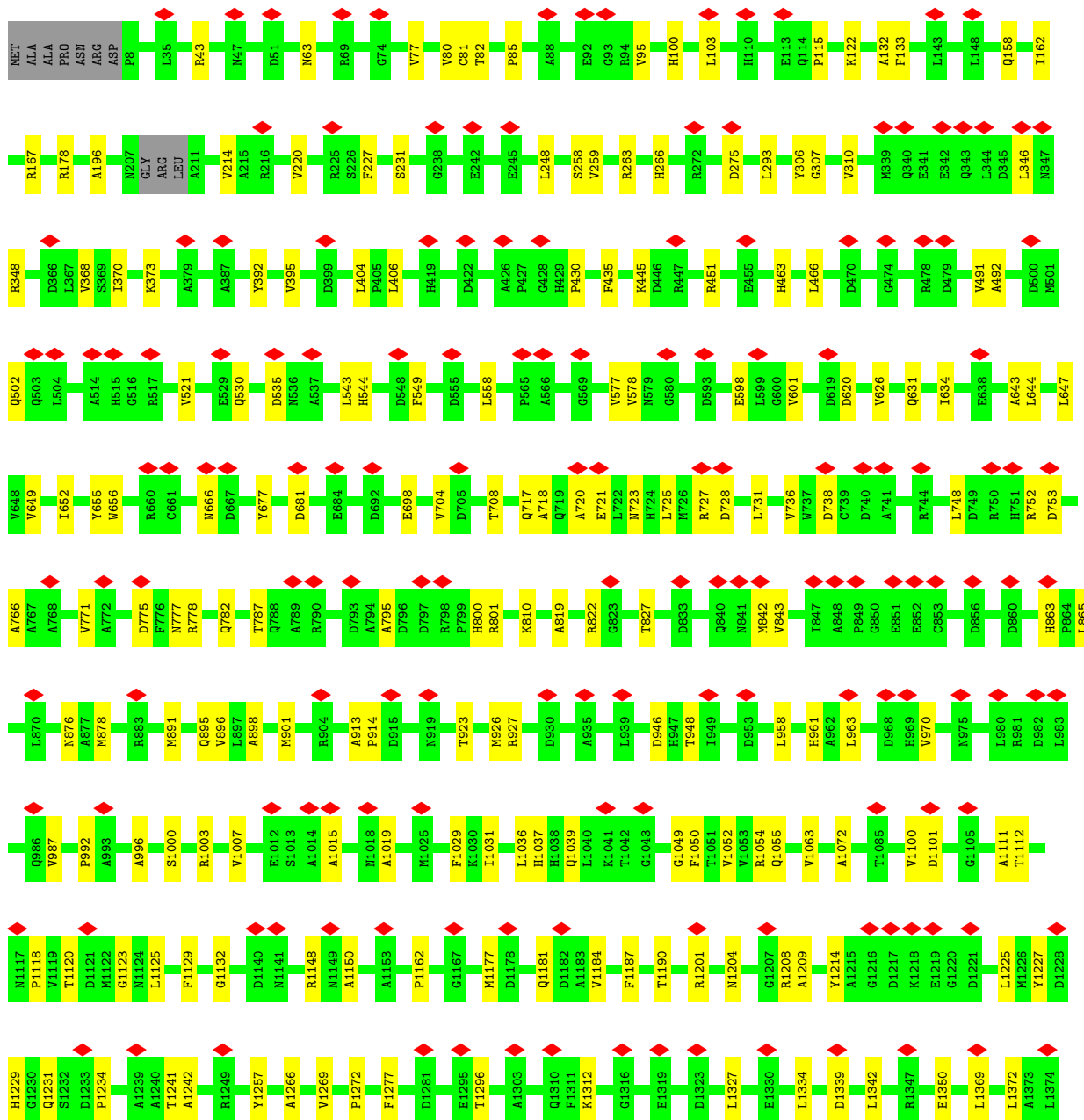
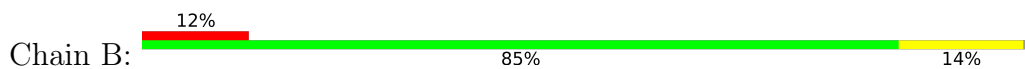

• Molecule 1: Major capsid protein

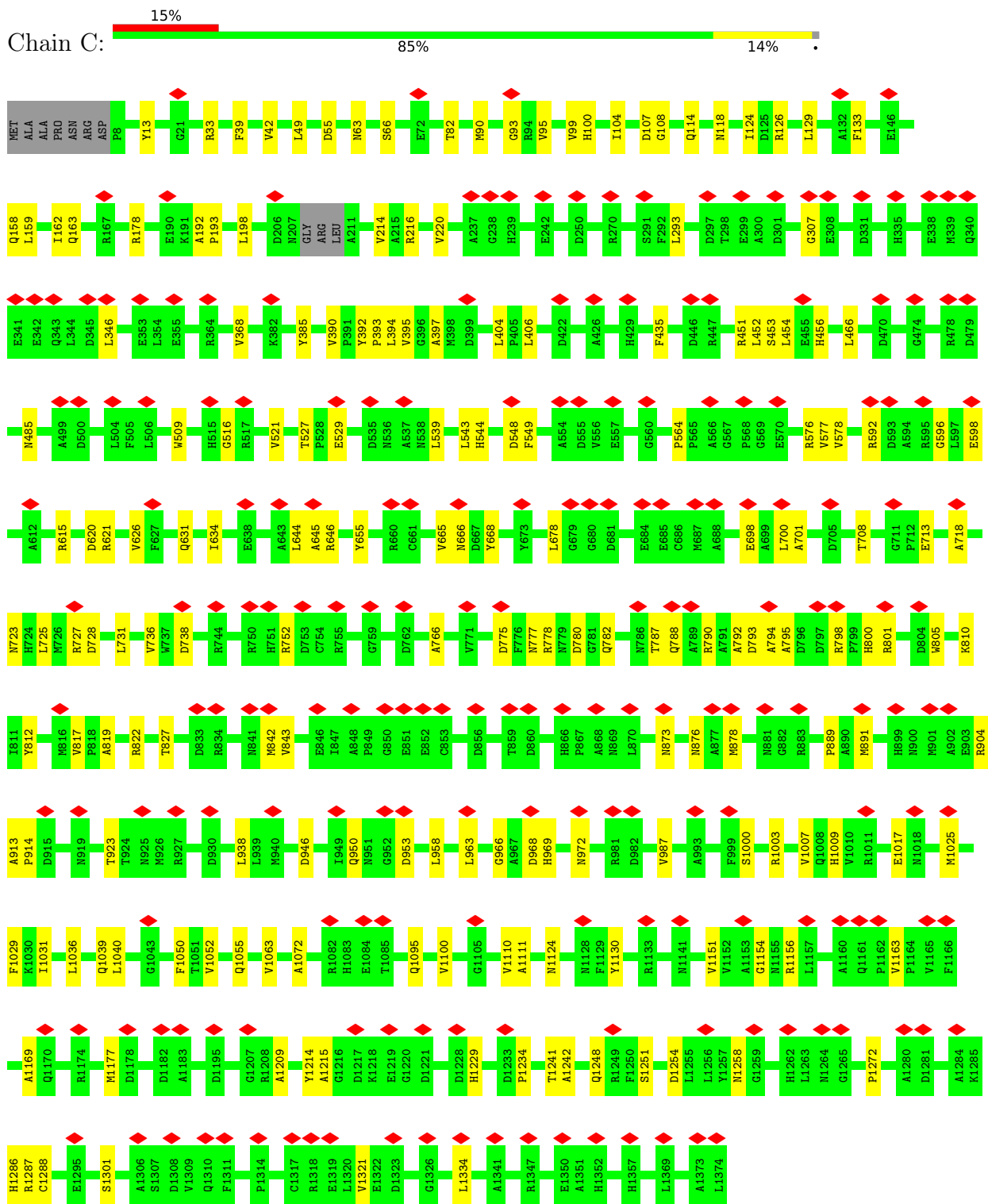

• Molecule 1: Major capsid protein

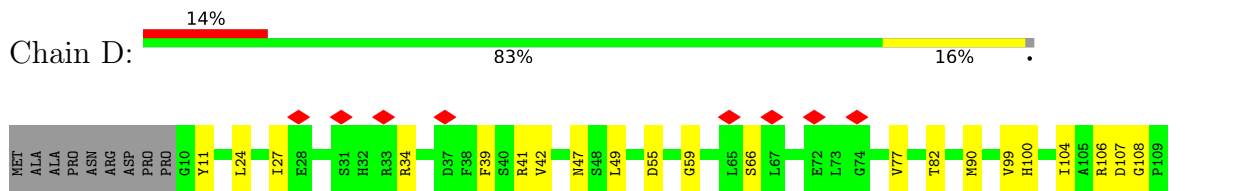

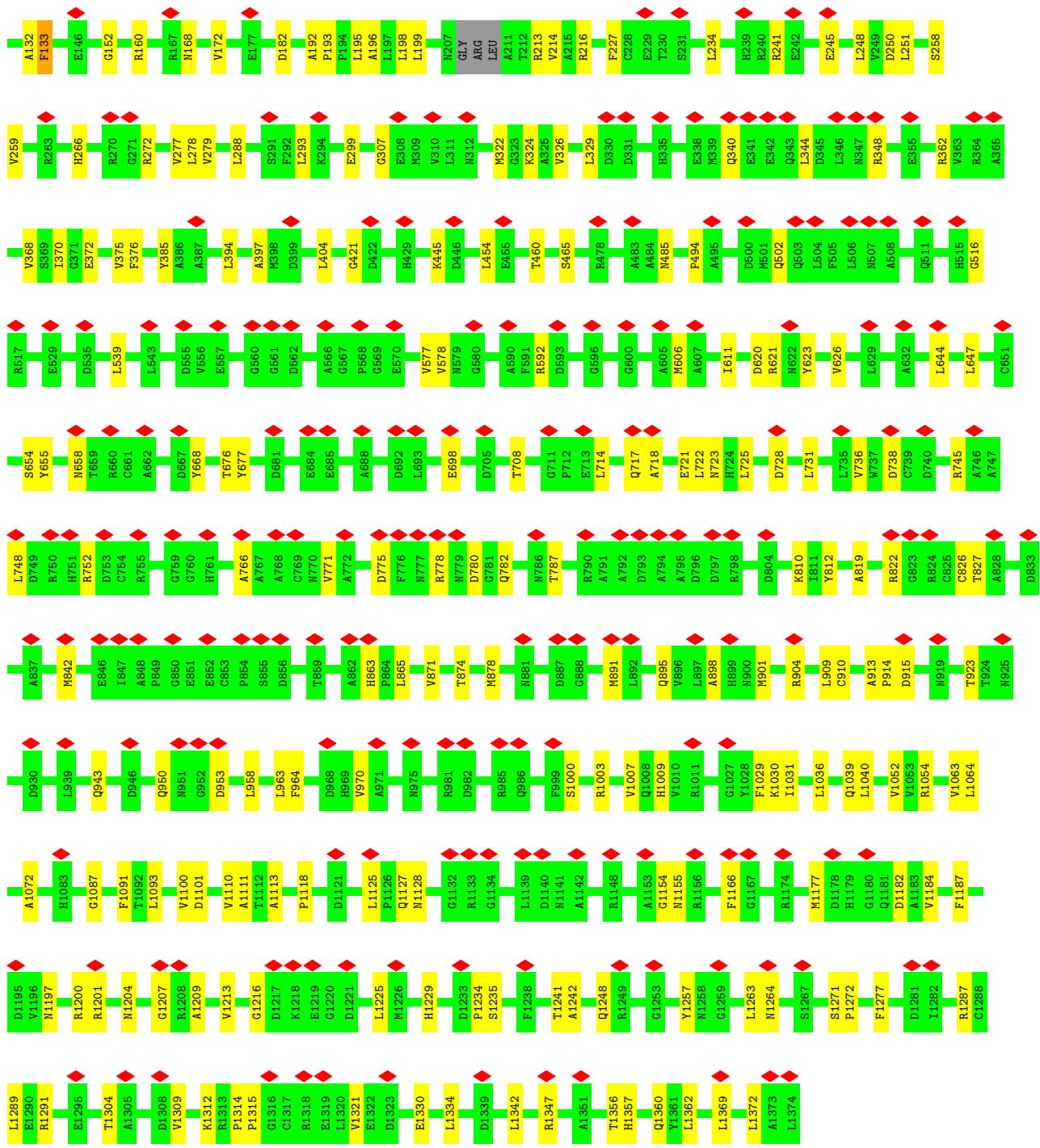

• Molecule 1: Major capsid protein

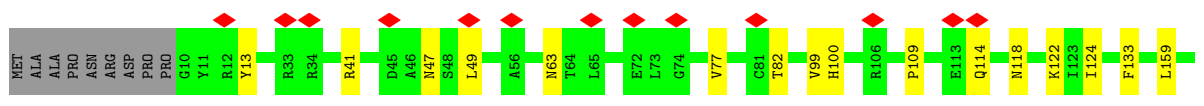
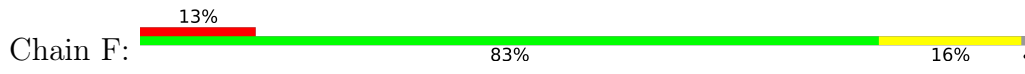

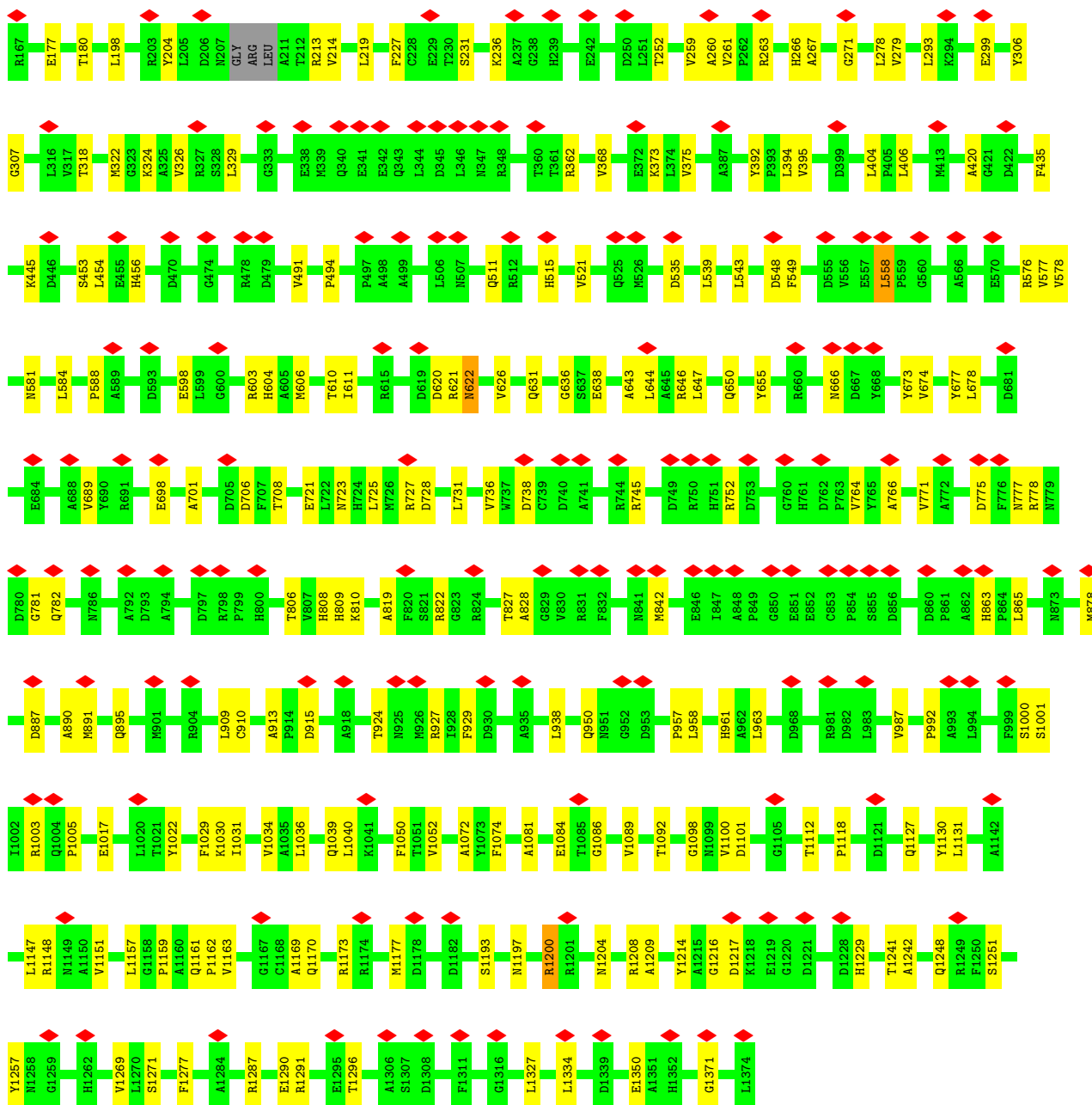

• Molecule 1: Major capsid protein

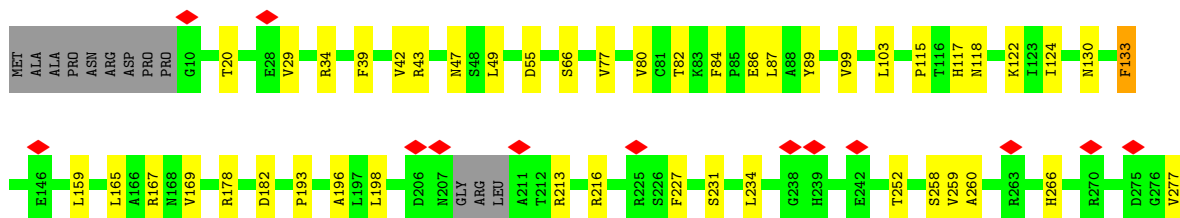
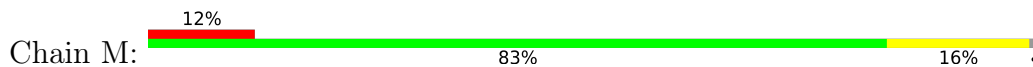

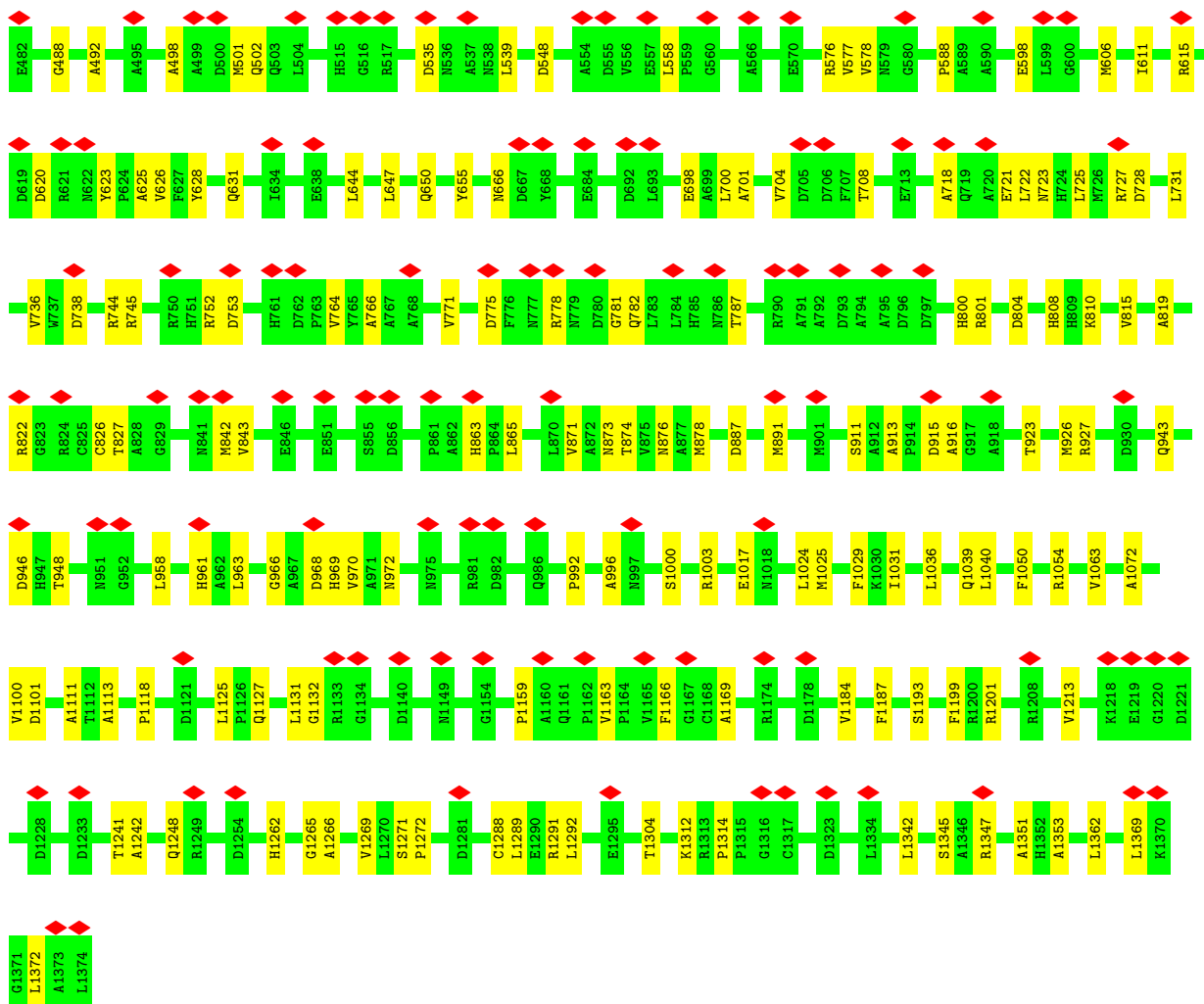

• Molecule 1: Major capsid protein

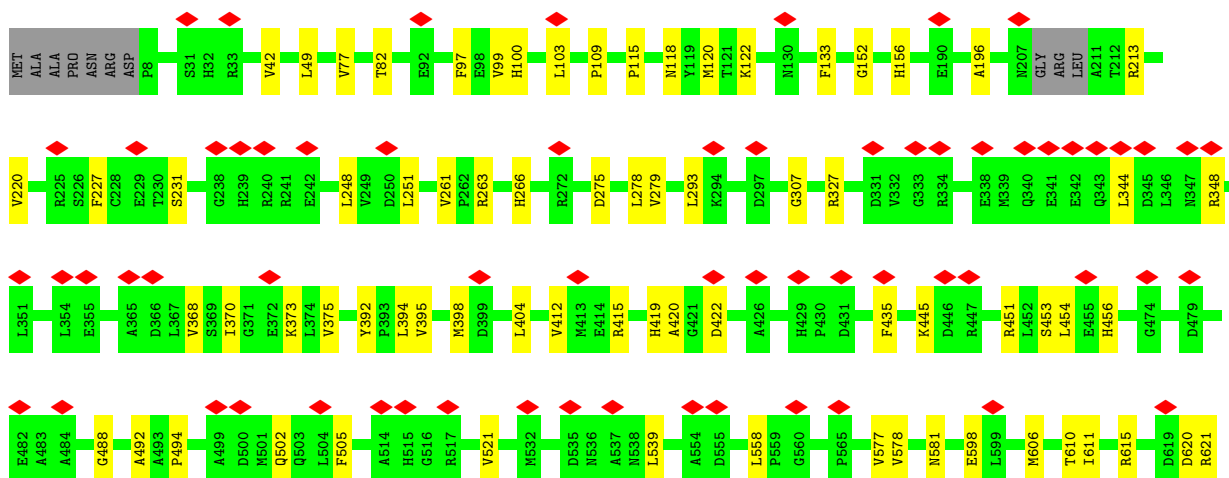
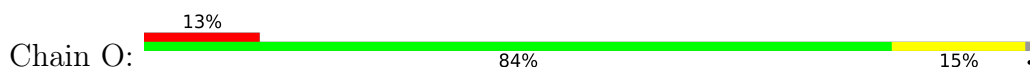

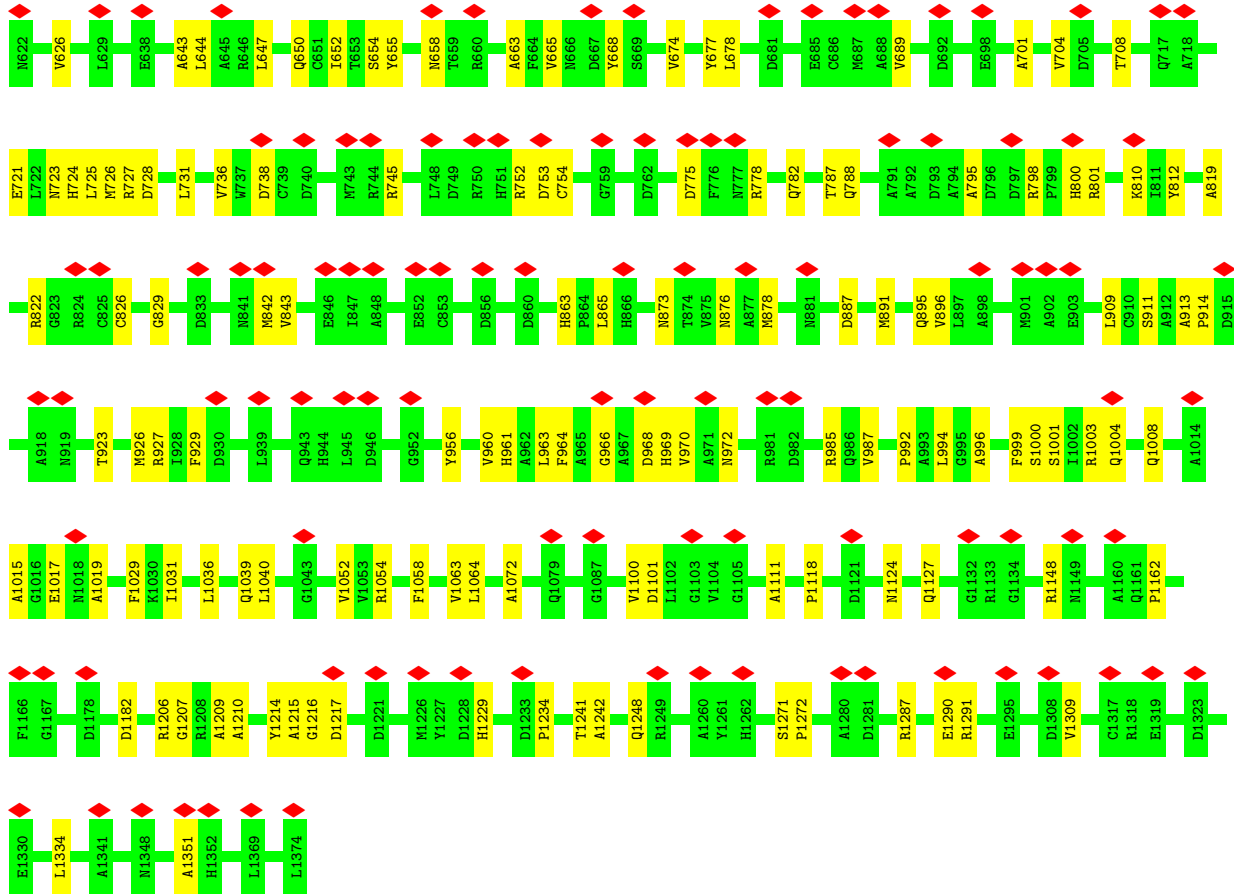

• Molecule 1: Major capsid protein

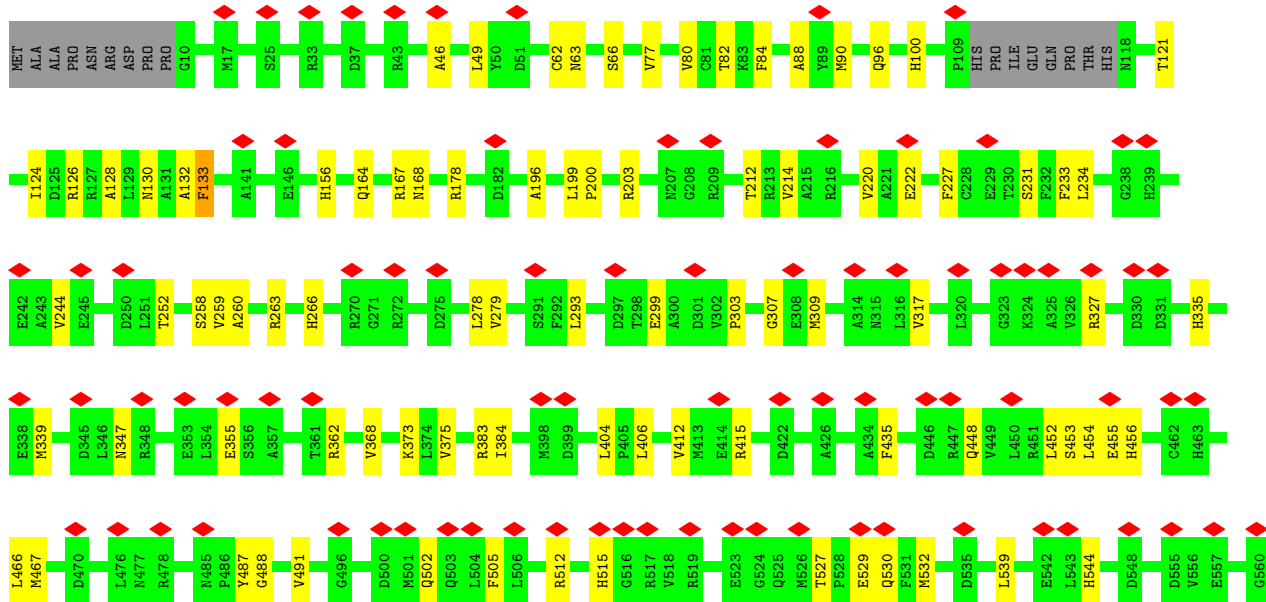
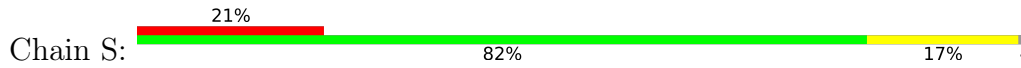

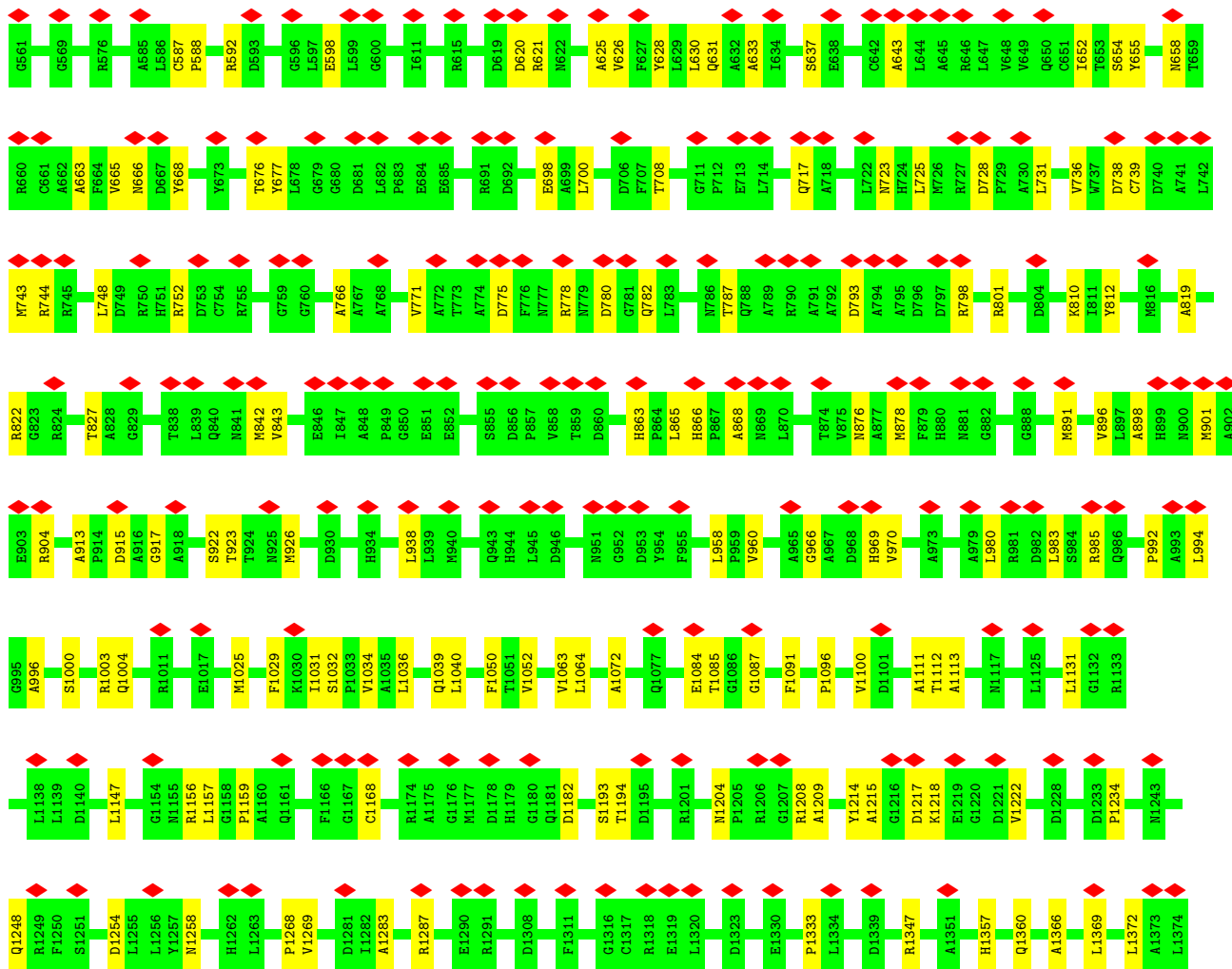

• Molecule 1: Major capsid protein

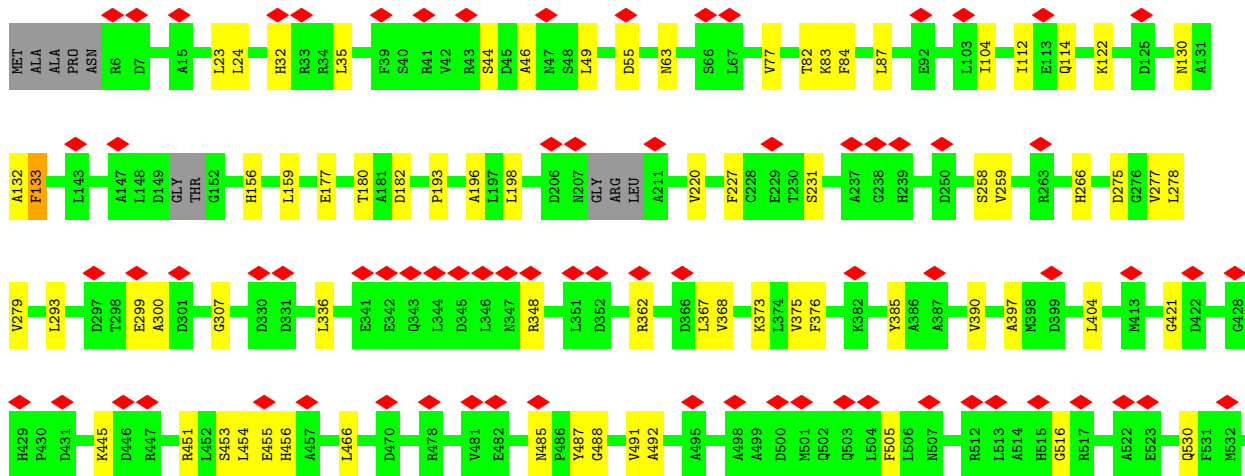
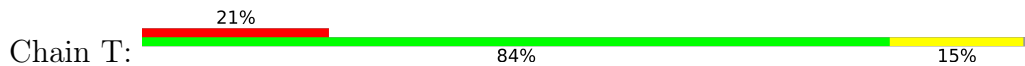

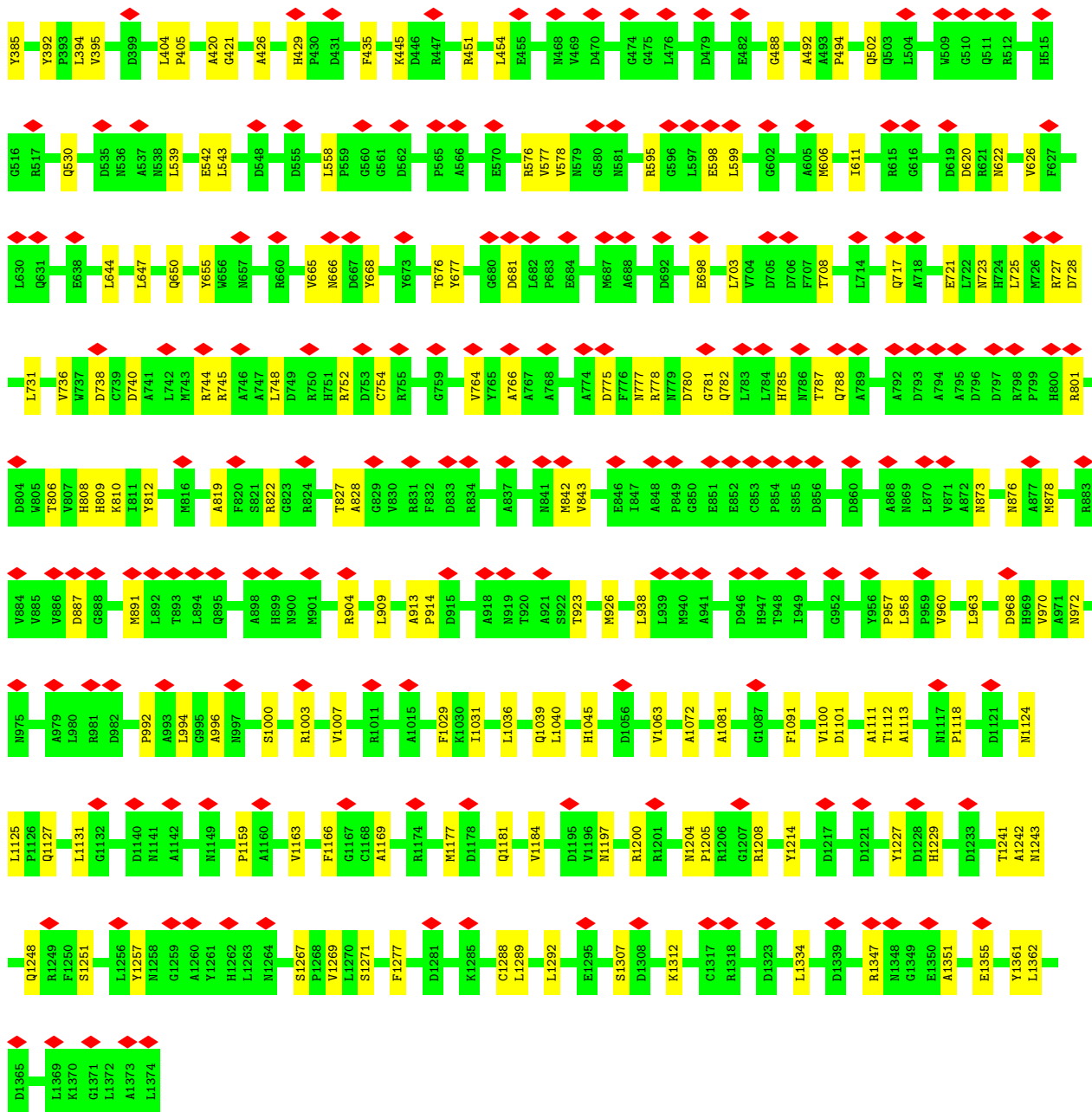

• Molecule 1: Major capsid protein

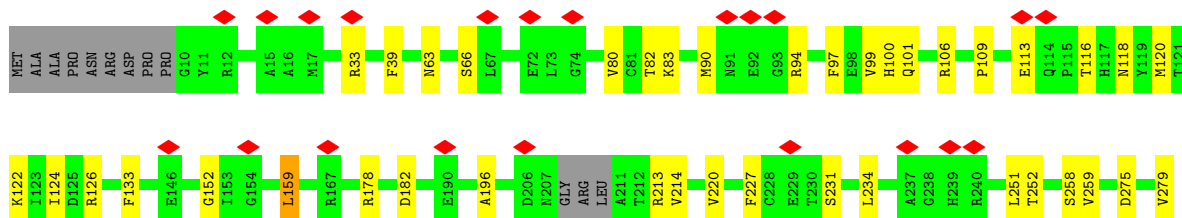
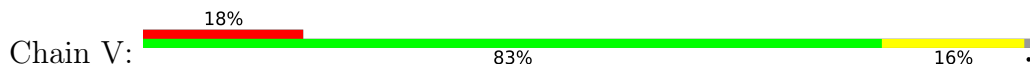



• Molecule 1: Major capsid protein

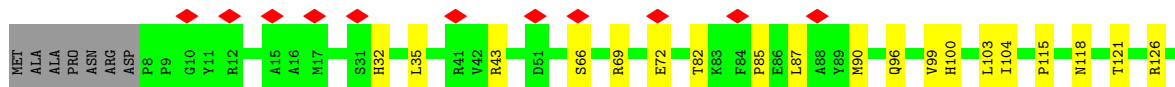
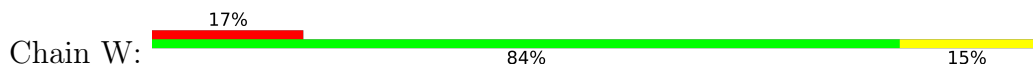

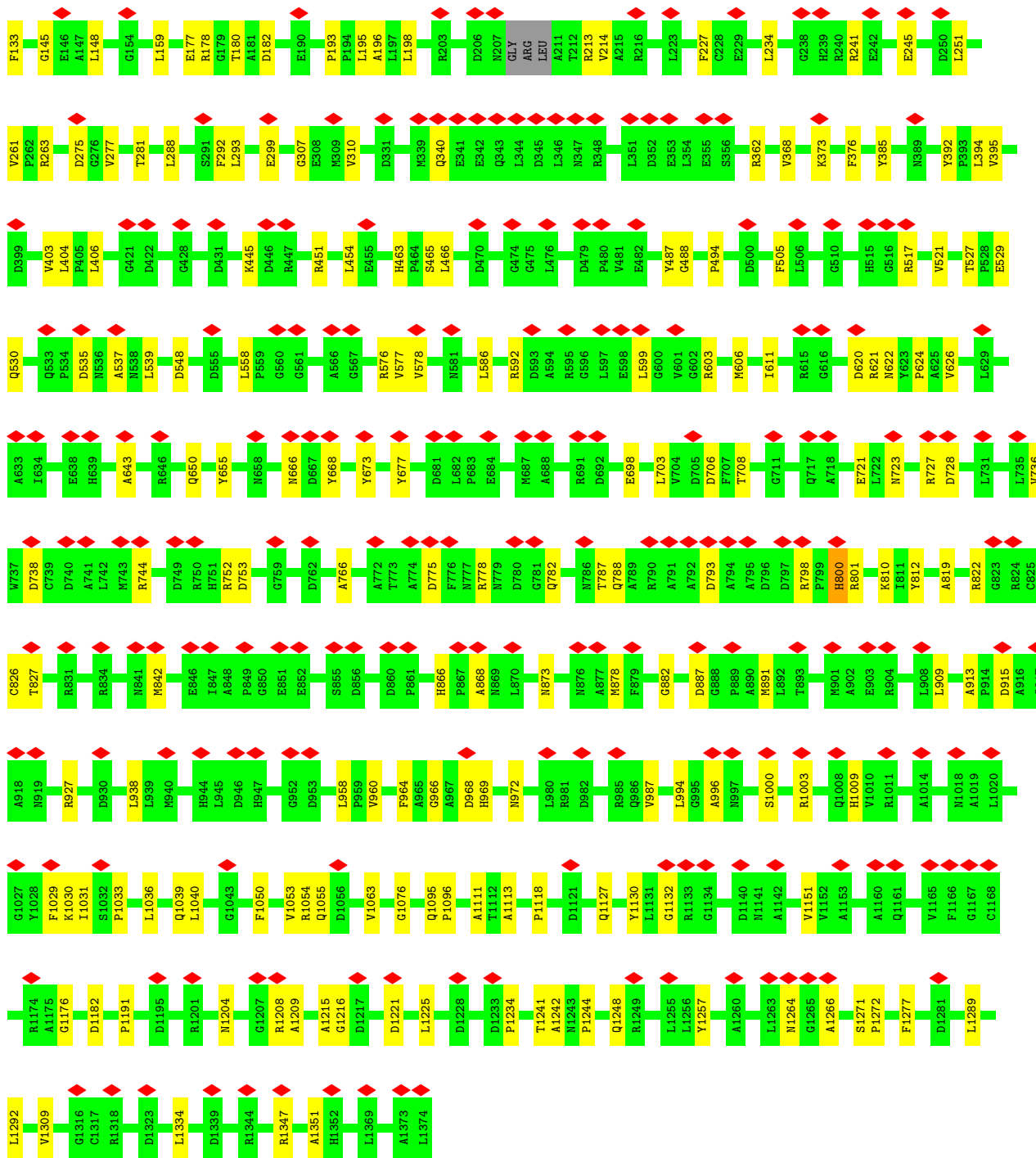

• Molecule 1: Major capsid protein

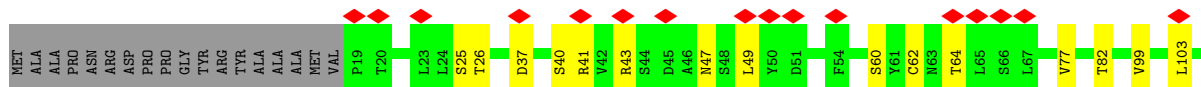
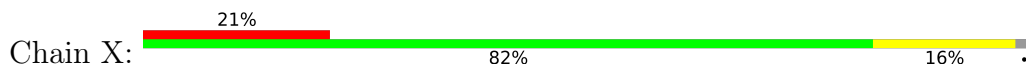

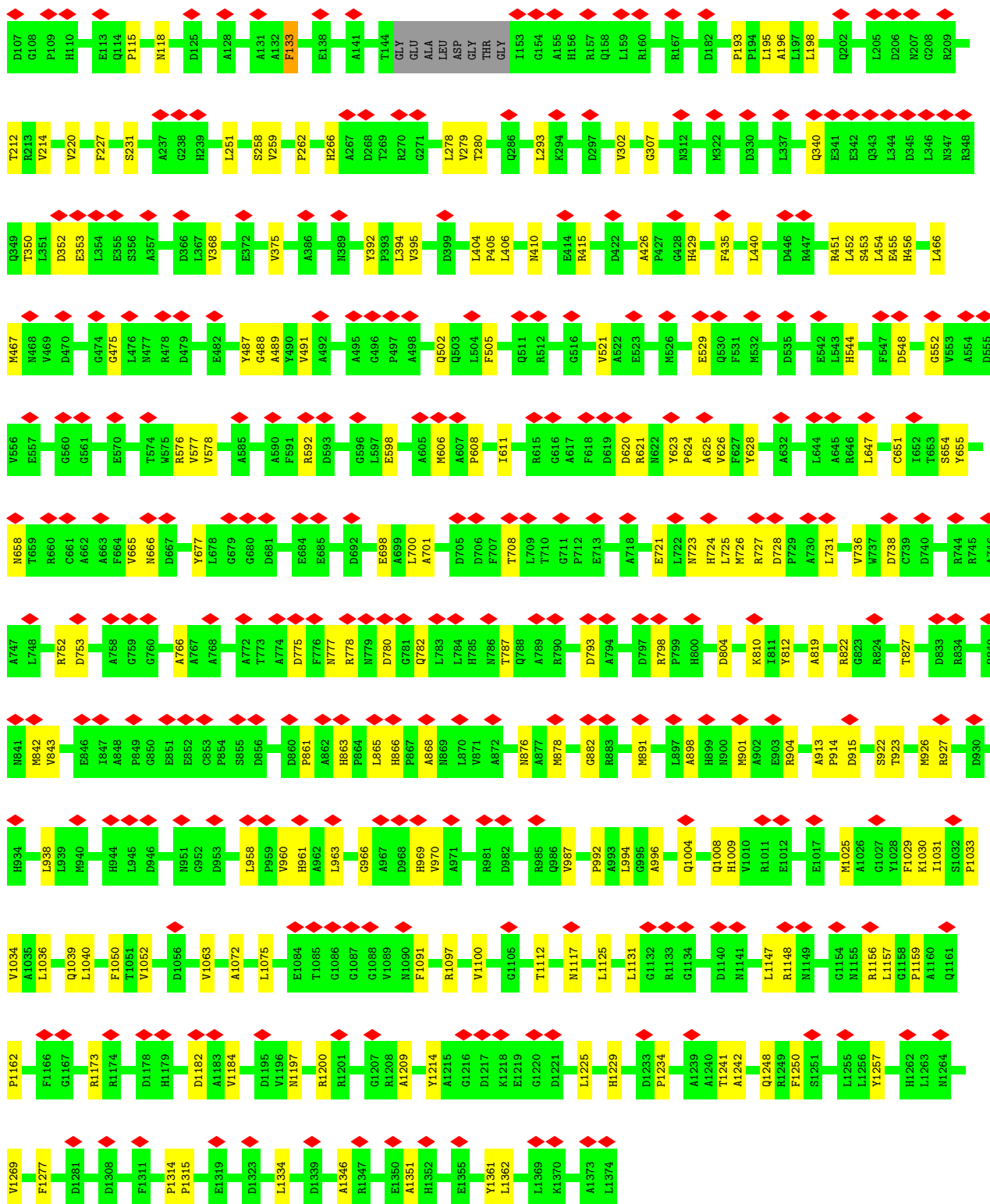

• Molecule 1: Major capsid protein

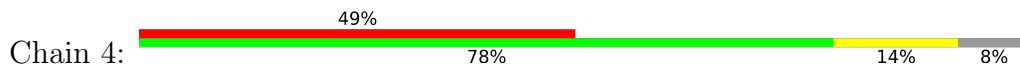

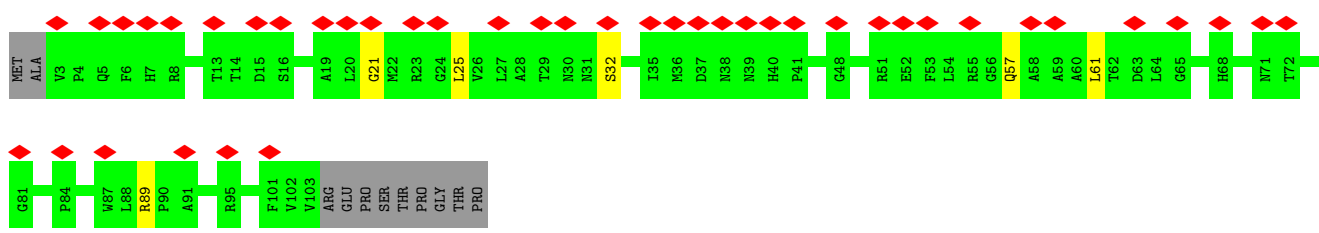
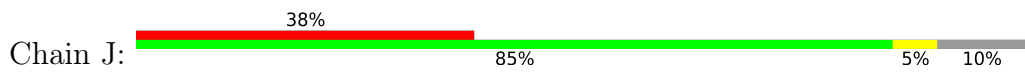

• Molecule 2: Small capsomere-interacting protein

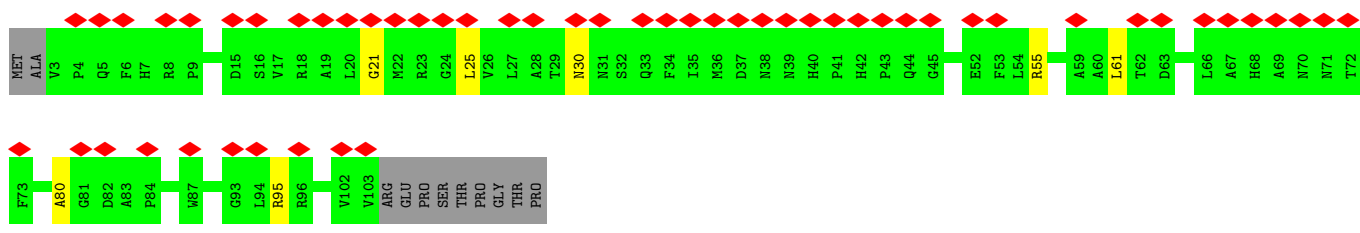
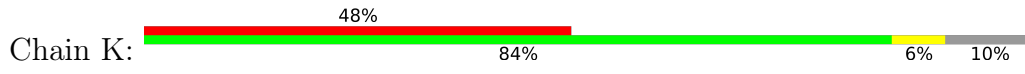

• Molecule 2: Small capsomere-interacting protein

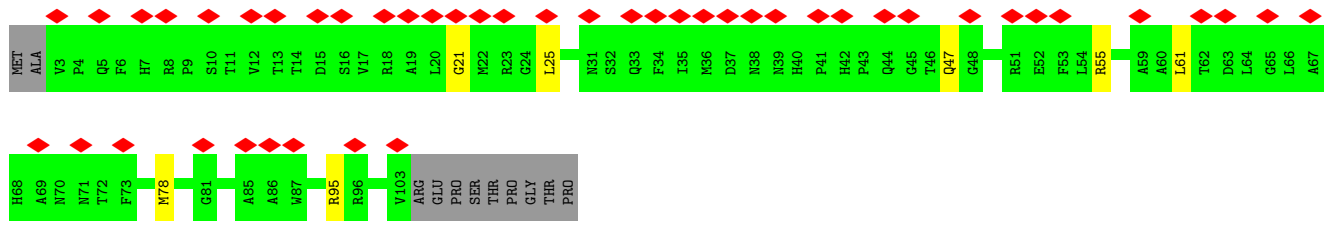
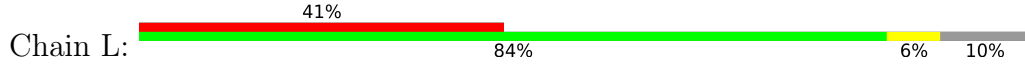

• Molecule 2: Small capsomere-interacting protein

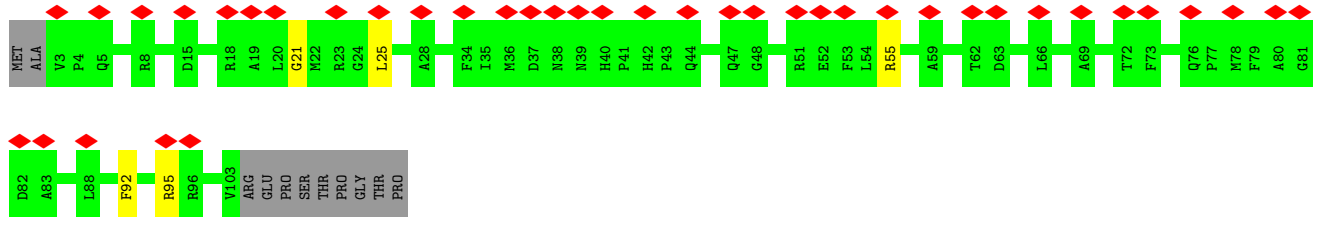
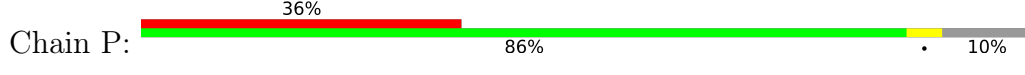

• Molecule 2: Small capsomere-interacting protein

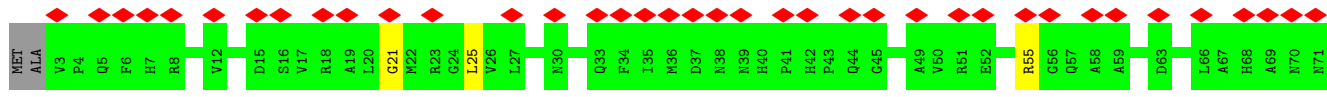
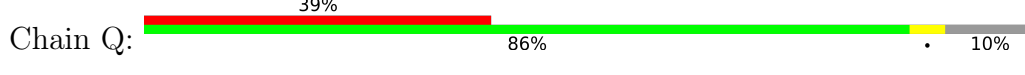

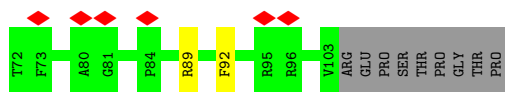

• Molecule 2: Small capsomere-interacting protein

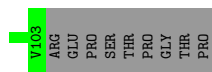
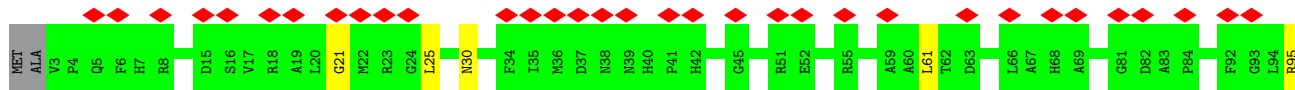
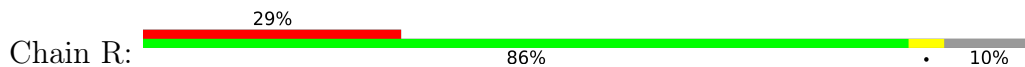

• Molecule 2: Small capsomere-interacting protein

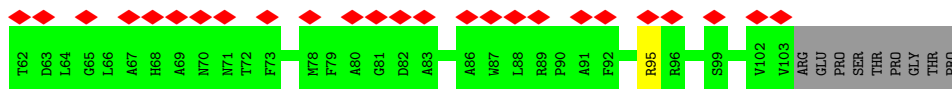
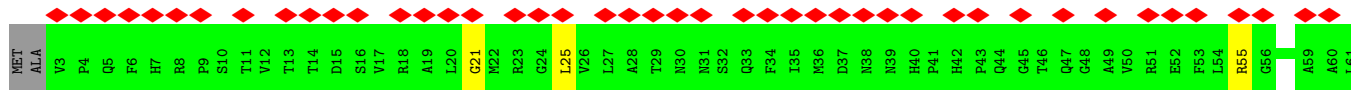
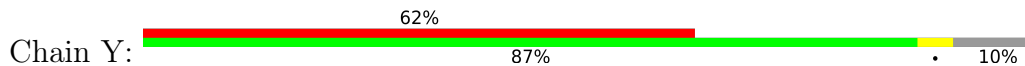

• Molecule 2: Small capsomere-interacting protein

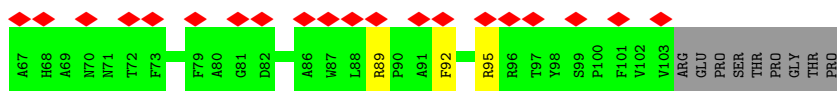
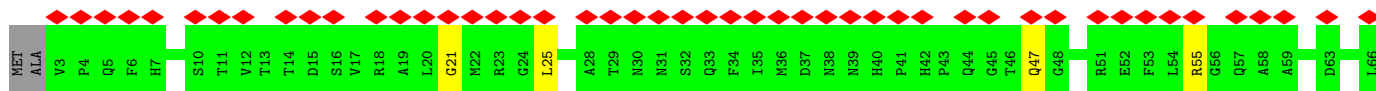
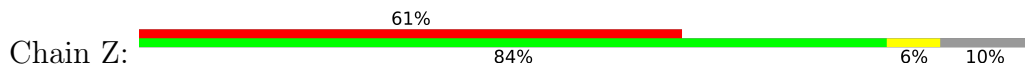

• Molecule 2: Small capsomere-interacting protein

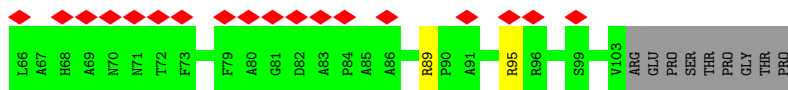
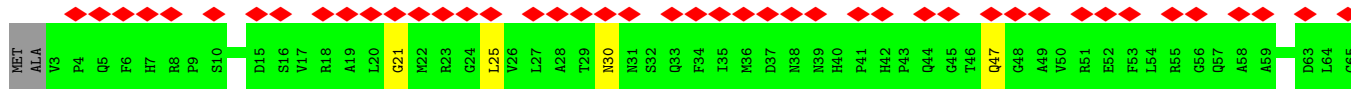
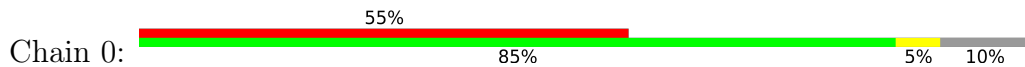

• Molecule 2: Small capsomere-interacting protein



• Molecule 3: Triplex capsid protein 1

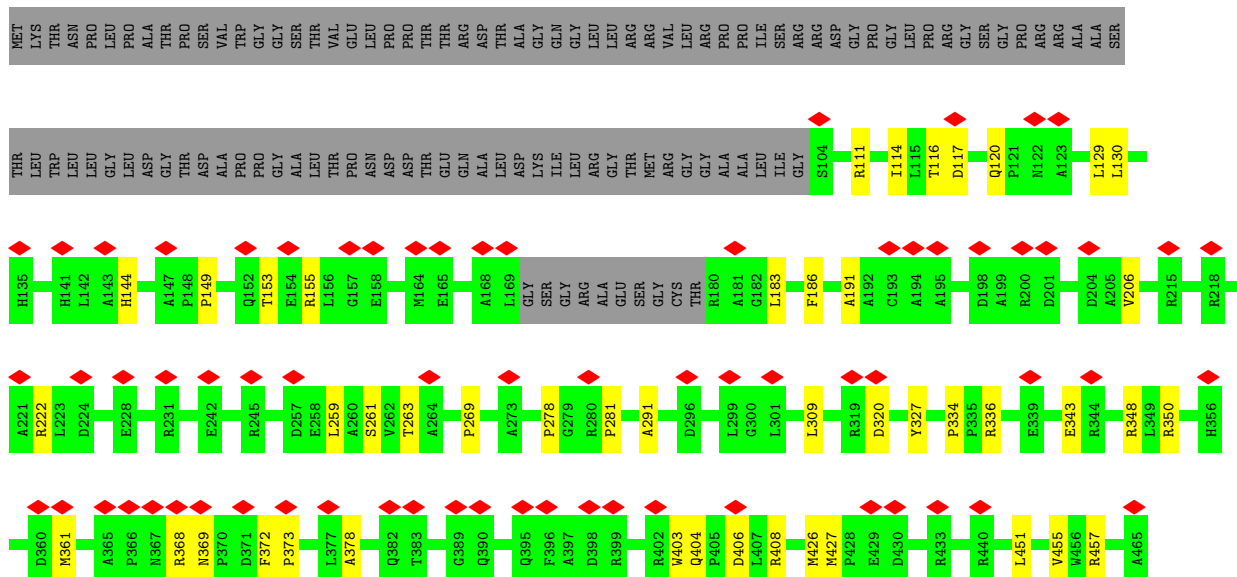

• Molecule 3: Triplex capsid protein 1

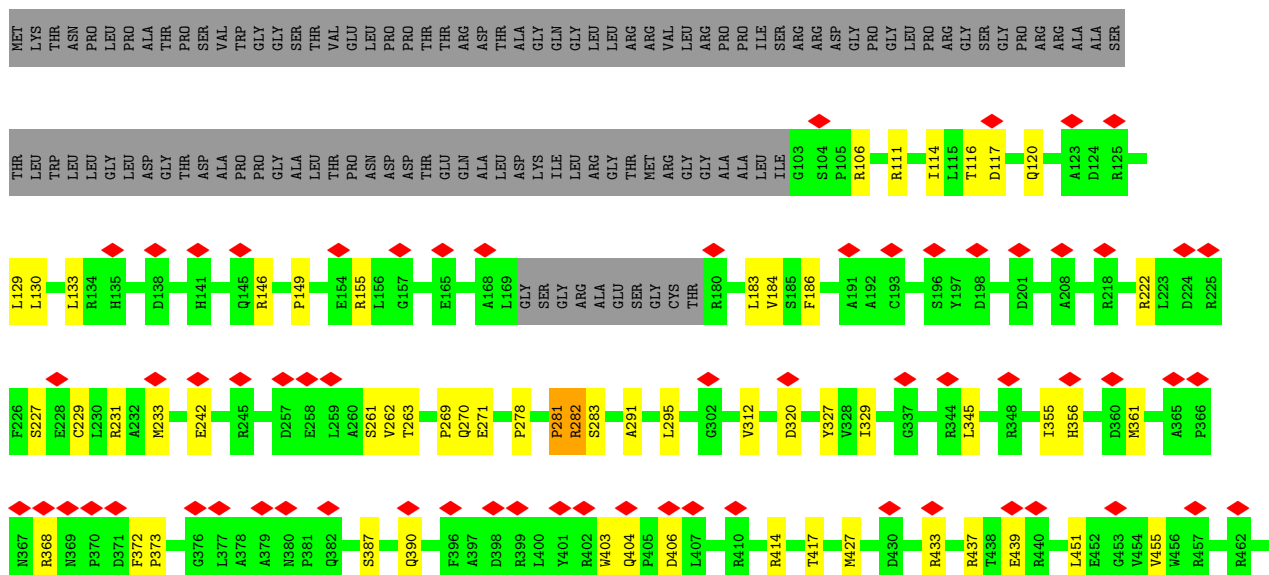

• Molecule 4: Triplex capsid protein 2

• Molecule 4: Triplex capsid protein 2

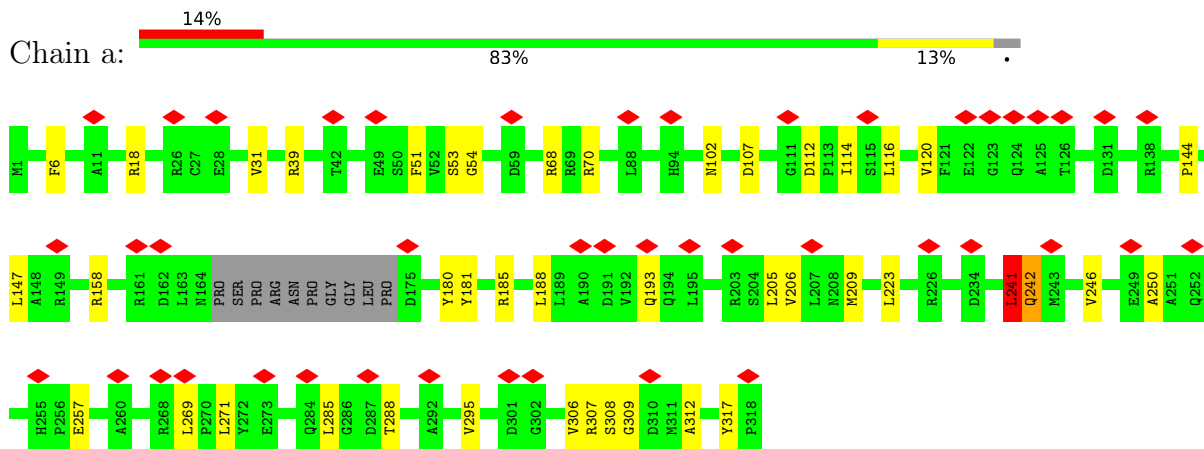

• Molecule 4: Triplex capsid protein 2

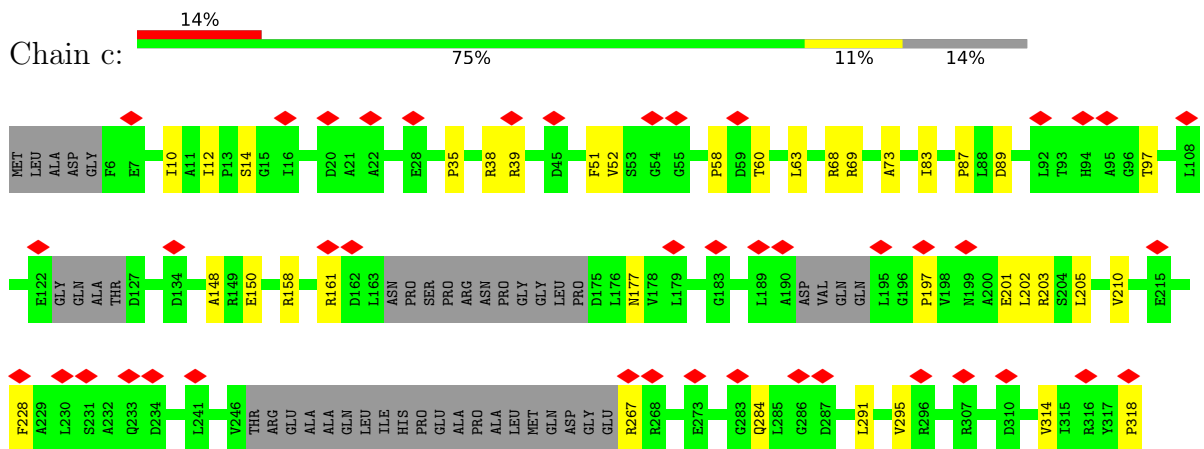

• Molecule 4: Triplex capsid protein 2

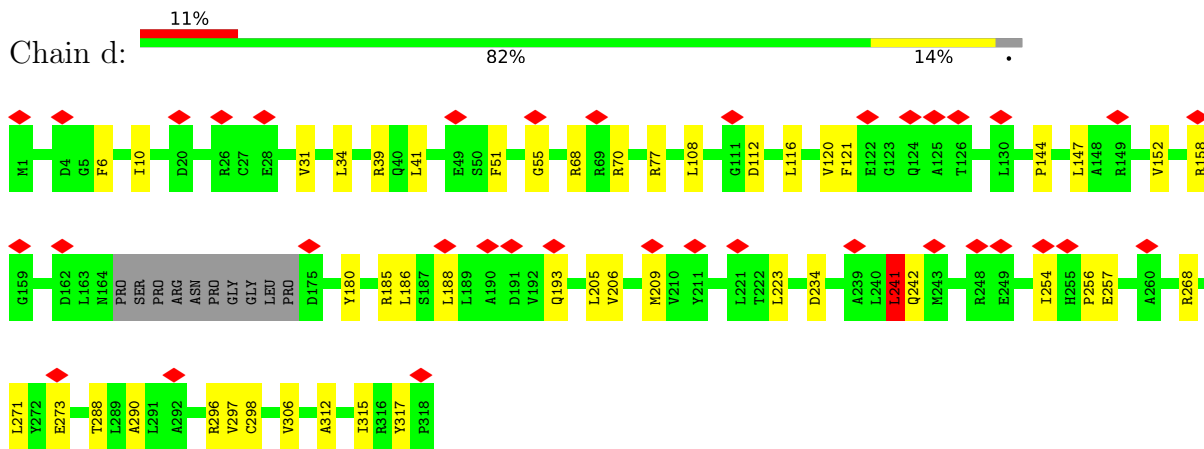

• Molecule 4: Triplex capsid protein 2



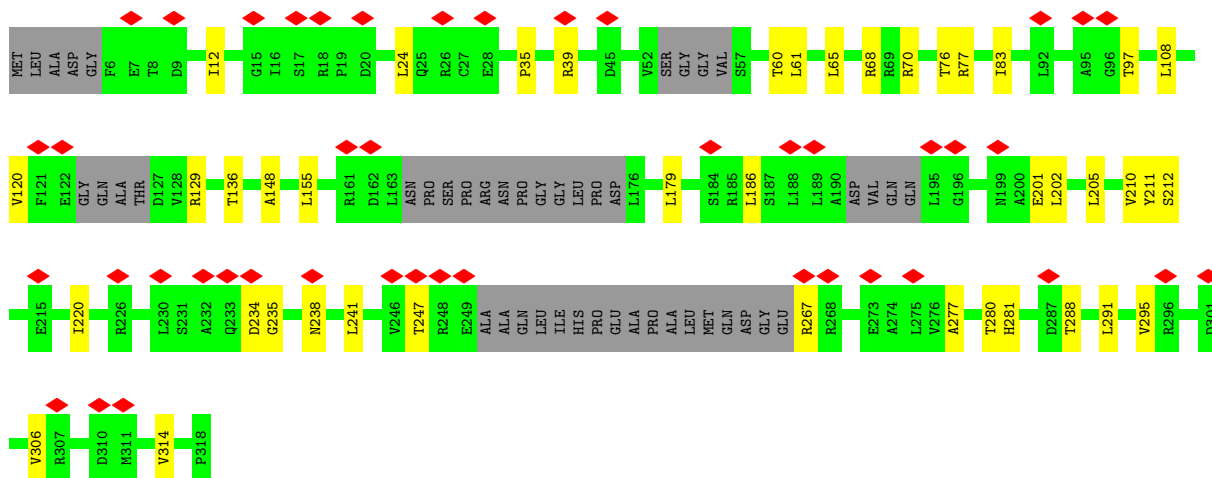

• Molecule 4: Triplex capsid protein 2

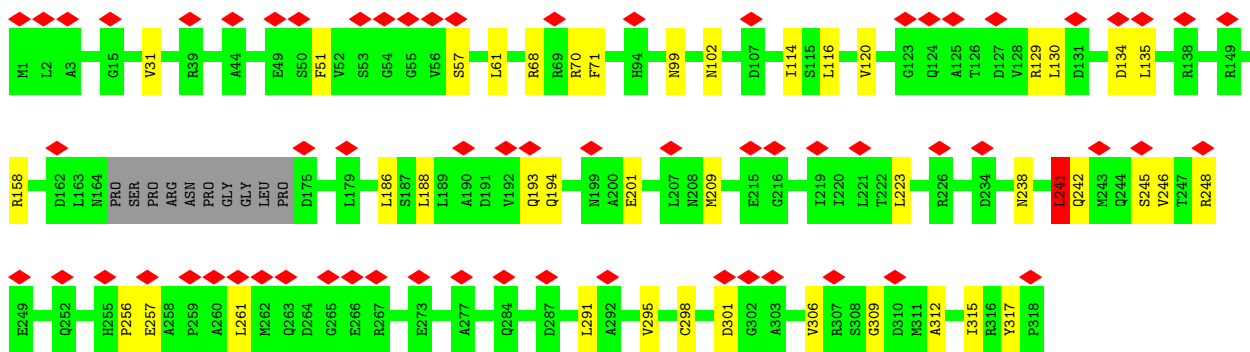
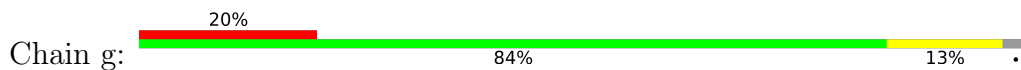

• Molecule 4: Triplex capsid protein 2

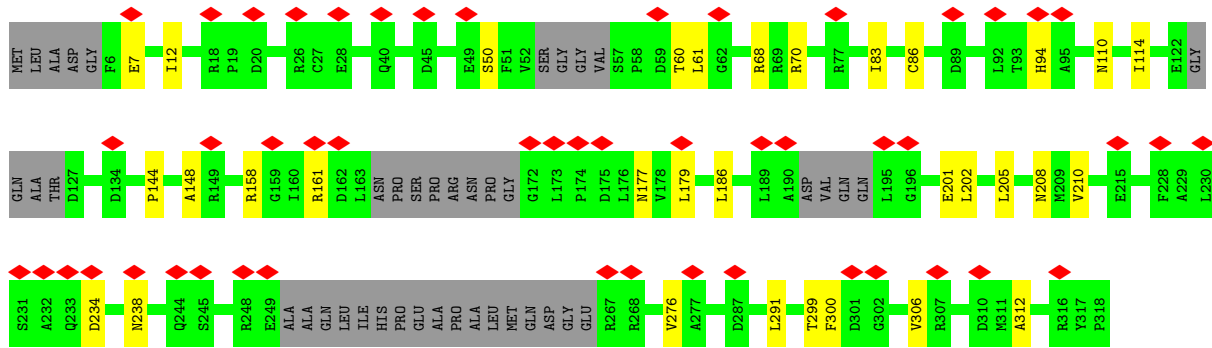
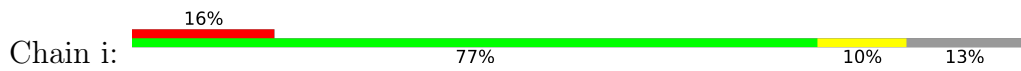

• Molecule 4: Triplex capsid protein 2

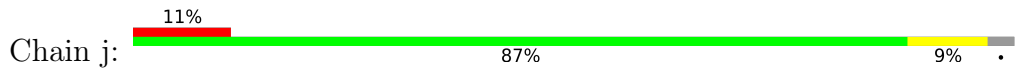

4 Experimental information

Property	Value	Source
EM reconstruction method	SINGLE PARTICLE	Depositor
Imposed symmetry	POINT, I	Depositor
Number of particles used	28042	Depositor
Resolution determination method	FSC 0.143 CUT-OFF	Depositor
CTF correction method	PHASE FLIPPING AND AMPLITUDE CORRECTION	Depositor
Microscope	FEI TITAN KRIOS	Depositor
Voltage (kV)	300	Depositor
Electron dose ($e^-/\text{\AA}^2$)	25	Depositor
Minimum defocus (nm)	2000	Depositor
Maximum defocus (nm)	2000	Depositor
Magnification	24271	Depositor
Image detector	GATAN K2 SUMMIT (4k x 4k)	Depositor
Maximum map value	14.209	Depositor
Minimum map value	-10.389	Depositor
Average map value	-0.000	Depositor
Map value standard deviation	0.999	Depositor
Recommended contour level	2.5	Depositor
Map size (Å)	1318.3999, 1318.3999, 1318.3999	wwPDB
Map dimensions	1280, 1280, 1280	wwPDB
Map angles (°)	90.0, 90.0, 90.0	wwPDB
Pixel spacing (Å)	1.03, 1.03, 1.03	Depositor

5 Model quality i

5.1 Standard geometry i

The Z score for a bond length (or angle) is the number of standard deviations the observed value is removed from the expected value. A bond length (or angle) with $|Z| > 5$ is considered an outlier worth inspection. RMSZ is the root-mean-square of all Z scores of the bond lengths (or angles).

Mol	Chain	Bond lengths		Bond angles	
		RMSZ	# Z >5	RMSZ	# Z >5
1	4	0.27	1/9878 (0.0%)	0.52	0/13478
1	A	0.31	1/10664 (0.0%)	0.54	0/14556
1	B	0.31	0/10680	0.57	0/14579
1	C	0.31	0/10680	0.55	0/14579
1	D	0.33	0/10664	0.58	0/14556
1	E	0.33	0/10699	0.58	0/14605
1	F	0.33	0/10664	0.57	2/14556 (0.0%)
1	M	0.33	0/10664	0.59	0/14556
1	N	0.33	0/10699	0.58	0/14605
1	O	0.31	0/10680	0.55	0/14579
1	S	0.31	1/10616 (0.0%)	0.55	0/14487
1	T	0.32	0/10631	0.58	0/14507
1	U	0.33	0/10680	0.58	0/14579
1	V	0.31	0/10664	0.58	0/14556
1	W	0.31	0/10680	0.55	0/14579
1	X	0.31	0/10567	0.56	0/14423
2	0	0.25	0/796	0.45	0/1087
2	1	0.25	0/796	0.45	0/1087
2	2	0.25	0/796	0.45	0/1087
2	3	0.25	0/796	0.45	0/1087
2	G	0.25	0/796	0.45	0/1087
2	H	0.25	0/796	0.45	0/1087
2	I	0.25	0/796	0.45	0/1087
2	J	0.25	0/796	0.45	0/1087
2	K	0.25	0/796	0.45	0/1087
2	L	0.25	0/796	0.46	0/1087
2	P	0.25	0/796	0.45	0/1087
2	Q	0.25	0/796	0.45	0/1087
2	R	0.25	0/796	0.45	0/1087
2	Y	0.25	0/796	0.46	0/1087
2	Z	0.25	0/796	0.45	0/1087
3	5	0.31	0/2795	0.53	0/3810
3	8	0.31	0/2858	0.57	0/3895
3	b	0.32	0/2858	0.56	0/3895

Mol	Chain	Bond lengths		Bond angles	
		RMSZ	# Z >5	RMSZ	# Z >5
3	e	0.28	0/2791	0.52	0/3805
3	h	0.29	0/2795	0.57	0/3810
4	6	0.29	0/2152	0.58	0/2939
4	7	0.30	0/2383	0.62	2/3259 (0.1%)
4	9	0.31	0/2127	0.57	0/2906
4	a	0.34	0/2383	0.64	2/3259 (0.1%)
4	c	0.31	0/2127	0.61	0/2906
4	d	0.34	0/2383	0.64	2/3259 (0.1%)
4	f	0.32	0/2124	0.59	0/2900
4	g	0.30	0/2383	0.59	2/3259 (0.1%)
4	i	0.30	0/2152	0.56	0/2939
4	j	0.31	0/2383	0.60	2/3259 (0.1%)
5	k	0.26	0/4307	0.53	0/5866
6	l	0.26	0/786	0.55	0/1072
6	m	0.27	0/670	0.53	0/912
7	n	0.16	0/388	0.39	0/521
7	o	0.16	0/388	0.39	0/521
All	All	0.31	3/224983 (0.0%)	0.56	12/307077 (0.0%)

Chiral center outliers are detected by calculating the chiral volume of a chiral center and verifying if the center is modelled as a planar moiety or with the opposite hand. A planarity outlier is detected by checking planarity of atoms in a peptide group, atoms in a mainchain group or atoms of a sidechain that are expected to be planar.

Mol	Chain	#Chirality outliers	#Planarity outliers
1	4	0	2
1	A	0	2
1	B	0	2
1	C	0	1
1	D	0	2
1	E	0	1
1	F	0	2
1	M	0	2
1	N	0	2
1	O	0	1
1	S	0	1
1	T	0	2
1	U	0	5
1	V	0	3
1	W	0	4
1	X	0	1
3	8	0	1

Continued on next page...

Continued from previous page...

Mol	Chain	#Chirality outliers	#Planarity outliers
3	h	0	1
4	7	0	1
4	9	0	1
4	a	0	1
4	d	0	1
4	g	0	1
4	j	0	1
All	All	0	41

All (3) bond length outliers are listed below:

Mol	Chain	Res	Type	Atoms	Z	Observed(Å)	Ideal(Å)
1	4	1004	GLN	C-N	5.34	1.39	1.34
1	S	1004	GLN	C-N	5.34	1.39	1.34
1	A	1004	GLN	C-N	5.04	1.39	1.34

The worst 5 of 12 bond angle outliers are listed below:

Mol	Chain	Res	Type	Atoms	Z	Observed(°)	Ideal(°)
4	g	241	LEU	CA-C-N	5.92	132.85	121.54
4	g	241	LEU	C-N-CA	5.92	132.85	121.54
4	d	241	LEU	CA-C-N	5.77	132.56	121.54
4	d	241	LEU	C-N-CA	5.77	132.56	121.54
4	a	241	LEU	CA-C-N	5.68	132.39	121.54

There are no chirality outliers.

5 of 41 planarity outliers are listed below:

Mol	Chain	Res	Type	Group
1	A	133	PHE	Peptide
1	A	800	HIS	Peptide
1	B	133	PHE	Peptide
1	B	43	ARG	Peptide
1	C	133	PHE	Peptide

5.2 Too-close contacts

In the following table, the Non-H and H(model) columns list the number of non-hydrogen atoms and hydrogen atoms in the chain respectively. The H(added) column lists the number of hydrogen atoms added and optimized by MolProbity. The Clashes column lists the number of clashes within the asymmetric unit, whereas Symm-Clashes lists symmetry-related clashes.

Mol	Chain	Non-H	H(model)	H(added)	Clashes	Symm-Clashes
1	4	9648	0	9479	108	0
1	A	10409	0	10214	123	0
1	B	10423	0	10229	119	0
1	C	10423	0	10229	119	0
1	D	10409	0	10214	148	0
1	E	10442	0	10245	152	0
1	F	10409	0	10214	139	0
1	M	10409	0	10214	134	0
1	N	10442	0	10245	130	0
1	O	10423	0	10229	121	0
1	S	10365	0	10181	142	0
1	T	10379	0	10181	127	0
1	U	10423	0	10229	152	0
1	V	10409	0	10214	146	0
1	W	10423	0	10229	124	0
1	X	10314	0	10133	131	0
2	0	774	0	754	6	0
2	1	774	0	754	6	0
2	2	774	0	754	4	0
2	3	774	0	754	4	0
2	G	774	0	754	3	0
2	H	774	0	754	7	0
2	I	774	0	754	5	0
2	J	774	0	754	5	0
2	K	774	0	754	6	0
2	L	774	0	754	6	0
2	P	774	0	754	4	0
2	Q	774	0	754	4	0
2	R	774	0	754	4	0
2	Y	774	0	754	3	0
2	Z	774	0	754	6	0
3	5	2724	0	2680	26	0
3	8	2786	0	2736	28	0
3	b	2786	0	2736	38	0
3	e	2720	0	2677	30	0
3	h	2724	0	2680	39	0
4	6	2116	0	2201	19	0
4	7	2341	0	2416	28	0
4	9	2091	0	2175	20	0
4	a	2341	0	2416	29	0
4	c	2091	0	2175	27	0
4	d	2341	0	2416	29	0
4	f	2089	0	2176	30	0

Continued on next page...

Continued from previous page...

Mol	Chain	Non-H	H(model)	H(added)	Clashes	Symm-Clashes
4	g	2341	0	2416	28	0
4	i	2116	0	2201	21	0
4	j	2341	0	2416	20	0
5	k	4206	0	4190	31	0
6	l	766	0	745	10	0
6	m	654	0	642	12	0
7	n	384	0	410	2	0
7	o	384	0	410	1	0
All	All	219702	0	216903	2337	0

The all-atom clashscore is defined as the number of clashes found per 1000 atoms (including hydrogen atoms). The all-atom clashscore for this structure is 5.

The worst 5 of 2337 close contacts within the same asymmetric unit are listed below, sorted by their clash magnitude.

Atom-1	Atom-2	Interatomic distance (Å)	Clash overlap (Å)
1:W:299:GLU:HB3	1:W:362:ARG:HD2	1.69	0.75
1:M:322:MET:HE1	1:V:324:LYS:HB2	1.68	0.75
5:k:97:HIS:HD1	5:k:177:TYR:HH	1.32	0.73
1:T:1347:ARG:HH12	1:U:1351:ALA:HA	1.54	0.72
1:N:97:PHE:HB2	1:N:120:MET:HB2	1.71	0.71

There are no symmetry-related clashes.

5.3 Torsion angles [i](#)

5.3.1 Protein backbone [i](#)

In the following table, the Percentiles column shows the percent Ramachandran outliers of the chain as a percentile score with respect to all PDB entries followed by that with respect to all EM entries.

The Analysed column shows the number of residues for which the backbone conformation was analysed, and the total number of residues.

Mol	Chain	Analysed	Favoured	Allowed	Outliers	Percentiles	
1	4	1243/1374 (90%)	1169 (94%)	74 (6%)	0	100	100
1	A	1358/1374 (99%)	1262 (93%)	96 (7%)	0	100	100
1	B	1360/1374 (99%)	1258 (92%)	102 (8%)	0	100	100

Continued on next page...

Continued from previous page...

Mol	Chain	Analysed	Favoured	Allowed	Outliers	Percentiles	
1	C	1360/1374 (99%)	1265 (93%)	95 (7%)	0	100	100
1	D	1358/1374 (99%)	1246 (92%)	112 (8%)	0	100	100
1	E	1362/1374 (99%)	1254 (92%)	108 (8%)	0	100	100
1	F	1358/1374 (99%)	1244 (92%)	114 (8%)	0	100	100
1	M	1358/1374 (99%)	1244 (92%)	114 (8%)	0	100	100
1	N	1362/1374 (99%)	1253 (92%)	108 (8%)	1 (0%)	48	82
1	O	1360/1374 (99%)	1260 (93%)	100 (7%)	0	100	100
1	S	1353/1374 (98%)	1272 (94%)	81 (6%)	0	100	100
1	T	1349/1374 (98%)	1272 (94%)	77 (6%)	0	100	100
1	U	1360/1374 (99%)	1244 (92%)	116 (8%)	0	100	100
1	V	1358/1374 (99%)	1247 (92%)	111 (8%)	0	100	100
1	W	1360/1374 (99%)	1252 (92%)	108 (8%)	0	100	100
1	X	1344/1374 (98%)	1260 (94%)	84 (6%)	0	100	100
2	0	99/112 (88%)	94 (95%)	5 (5%)	0	100	100
2	1	99/112 (88%)	94 (95%)	5 (5%)	0	100	100
2	2	99/112 (88%)	94 (95%)	5 (5%)	0	100	100
2	3	99/112 (88%)	94 (95%)	5 (5%)	0	100	100
2	G	99/112 (88%)	94 (95%)	5 (5%)	0	100	100
2	H	99/112 (88%)	94 (95%)	5 (5%)	0	100	100
2	I	99/112 (88%)	94 (95%)	5 (5%)	0	100	100
2	J	99/112 (88%)	94 (95%)	5 (5%)	0	100	100
2	K	99/112 (88%)	94 (95%)	5 (5%)	0	100	100
2	L	99/112 (88%)	94 (95%)	5 (5%)	0	100	100
2	P	99/112 (88%)	94 (95%)	5 (5%)	0	100	100
2	Q	99/112 (88%)	94 (95%)	5 (5%)	0	100	100
2	R	99/112 (88%)	94 (95%)	5 (5%)	0	100	100
2	Y	99/112 (88%)	94 (95%)	5 (5%)	0	100	100
2	Z	99/112 (88%)	94 (95%)	5 (5%)	0	100	100
3	5	349/465 (75%)	332 (95%)	17 (5%)	0	100	100
3	8	361/465 (78%)	340 (94%)	20 (6%)	1 (0%)	36	71
3	b	361/465 (78%)	341 (94%)	20 (6%)	0	100	100

Continued on next page...

Continued from previous page...

Mol	Chain	Analysed	Favoured	Allowed	Outliers	Percentiles	
3	e	348/465 (75%)	324 (93%)	24 (7%)	0	100	100
3	h	349/465 (75%)	326 (93%)	22 (6%)	1 (0%)	36	71
4	6	264/318 (83%)	249 (94%)	15 (6%)	0	100	100
4	7	304/318 (96%)	283 (93%)	19 (6%)	2 (1%)	18	54
4	9	264/318 (83%)	244 (92%)	20 (8%)	0	100	100
4	a	304/318 (96%)	277 (91%)	25 (8%)	2 (1%)	18	54
4	c	264/318 (83%)	246 (93%)	17 (6%)	1 (0%)	30	66
4	d	304/318 (96%)	274 (90%)	27 (9%)	3 (1%)	12	47
4	f	260/318 (82%)	238 (92%)	21 (8%)	1 (0%)	30	66
4	g	304/318 (96%)	276 (91%)	28 (9%)	0	100	100
4	i	264/318 (83%)	246 (93%)	18 (7%)	0	100	100
4	j	304/318 (96%)	273 (90%)	30 (10%)	1 (0%)	36	71
5	k	534/703 (76%)	514 (96%)	20 (4%)	0	100	100
6	l	92/580 (16%)	87 (95%)	5 (5%)	0	100	100
6	m	78/580 (13%)	77 (99%)	1 (1%)	0	100	100
7	n	45/3139 (1%)	45 (100%)	0	0	100	100
7	o	45/3139 (1%)	45 (100%)	0	0	100	100
All	All	28486/37310 (76%)	26449 (93%)	2024 (7%)	13 (0%)	100	100

5 of 13 Ramachandran outliers are listed below:

Mol	Chain	Res	Type
3	8	282	ARG
4	7	241	LEU
4	d	241	LEU
4	d	242	GLN
3	h	282	ARG

5.3.2 Protein sidechains [i](#)

In the following table, the Percentiles column shows the percent sidechain outliers of the chain as a percentile score with respect to all PDB entries followed by that with respect to all EM entries.

The Analysed column shows the number of residues for which the sidechain conformation was analysed, and the total number of residues.

Mol	Chain	Analysed	Rotameric	Outliers	Percentiles	
1	4	1003/1085 (92%)	1003 (100%)	0	100	100
1	A	1076/1085 (99%)	1076 (100%)	0	100	100
1	B	1078/1085 (99%)	1076 (100%)	2 (0%)	87	85
1	C	1078/1085 (99%)	1078 (100%)	0	100	100
1	D	1076/1085 (99%)	1076 (100%)	0	100	100
1	E	1080/1085 (100%)	1080 (100%)	0	100	100
1	F	1076/1085 (99%)	1075 (100%)	1 (0%)	88	88
1	M	1076/1085 (99%)	1076 (100%)	0	100	100
1	N	1080/1085 (100%)	1079 (100%)	1 (0%)	88	88
1	O	1078/1085 (99%)	1077 (100%)	1 (0%)	88	88
1	S	1070/1085 (99%)	1070 (100%)	0	100	100
1	T	1073/1085 (99%)	1073 (100%)	0	100	100
1	U	1078/1085 (99%)	1077 (100%)	1 (0%)	88	88
1	V	1076/1085 (99%)	1076 (100%)	0	100	100
1	W	1078/1085 (99%)	1077 (100%)	1 (0%)	88	88
1	X	1069/1085 (98%)	1069 (100%)	0	100	100
2	0	80/89 (90%)	80 (100%)	0	100	100
2	1	80/89 (90%)	80 (100%)	0	100	100
2	2	80/89 (90%)	80 (100%)	0	100	100
2	3	80/89 (90%)	80 (100%)	0	100	100
2	G	80/89 (90%)	80 (100%)	0	100	100
2	H	80/89 (90%)	80 (100%)	0	100	100
2	I	80/89 (90%)	80 (100%)	0	100	100
2	J	80/89 (90%)	80 (100%)	0	100	100
2	K	80/89 (90%)	80 (100%)	0	100	100
2	L	80/89 (90%)	80 (100%)	0	100	100
2	P	80/89 (90%)	80 (100%)	0	100	100
2	Q	80/89 (90%)	80 (100%)	0	100	100
2	R	80/89 (90%)	80 (100%)	0	100	100
2	Y	80/89 (90%)	80 (100%)	0	100	100
2	Z	80/89 (90%)	80 (100%)	0	100	100
3	5	279/364 (77%)	279 (100%)	0	100	100

Continued on next page...

Continued from previous page...

Mol	Chain	Analysed	Rotameric	Outliers	Percentiles	
3	8	285/364 (78%)	285 (100%)	0	100	100
3	b	285/364 (78%)	285 (100%)	0	100	100
3	e	279/364 (77%)	279 (100%)	0	100	100
3	h	279/364 (77%)	279 (100%)	0	100	100
4	6	234/264 (89%)	234 (100%)	0	100	100
4	7	256/264 (97%)	256 (100%)	0	100	100
4	9	231/264 (88%)	231 (100%)	0	100	100
4	a	256/264 (97%)	256 (100%)	0	100	100
4	c	231/264 (88%)	231 (100%)	0	100	100
4	d	256/264 (97%)	256 (100%)	0	100	100
4	f	231/264 (88%)	231 (100%)	0	100	100
4	g	256/264 (97%)	255 (100%)	1 (0%)	84	82
4	i	234/264 (89%)	234 (100%)	0	100	100
4	j	256/264 (97%)	256 (100%)	0	100	100
5	k	429/529 (81%)	429 (100%)	0	100	100
6	l	80/448 (18%)	80 (100%)	0	100	100
6	m	67/448 (15%)	67 (100%)	0	100	100
7	n	41/2430 (2%)	41 (100%)	0	100	100
7	o	41/2430 (2%)	41 (100%)	0	100	100
All	All	22851/29440 (78%)	22843 (100%)	8 (0%)	100	100

5 of 8 residues with a non-rotameric sidechain are listed below:

Mol	Chain	Res	Type
4	g	186	LEU
1	W	558	LEU
1	O	558	LEU
1	N	558	LEU
1	U	558	LEU

Sometimes sidechains can be flipped to improve hydrogen bonding and reduce clashes. 5 of 491 such sidechains are listed below:

Mol	Chain	Res	Type
1	O	1004	GLN

Continued on next page...

Continued from previous page...

Mol	Chain	Res	Type
4	7	177	ASN
1	T	717	GLN
3	5	235	HIS
4	g	193	GLN

5.3.3 RNA [i](#)

There are no RNA molecules in this entry.

5.4 Non-standard residues in protein, DNA, RNA chains [i](#)

There are no non-standard protein/DNA/RNA residues in this entry.

5.5 Carbohydrates [i](#)

There are no oligosaccharides in this entry.

5.6 Ligand geometry [i](#)

There are no ligands in this entry.

5.7 Other polymers [i](#)

There are no such residues in this entry.

5.8 Polymer linkage issues [i](#)

There are no chain breaks in this entry.

6 Map visualisation [i](#)

This section contains visualisations of the EMDB entry EMD-7472. These allow visual inspection of the internal detail of the map and identification of artifacts.

No raw map or half-maps were deposited for this entry and therefore no images, graphs, etc. pertaining to the raw map can be shown.

6.1 Orthogonal projections [i](#)

6.1.1 Primary map

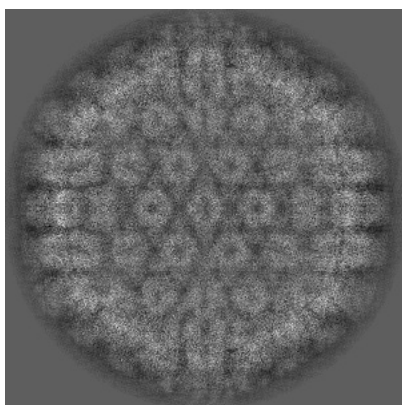

X

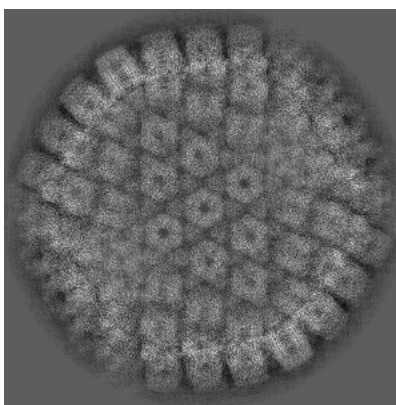

Y

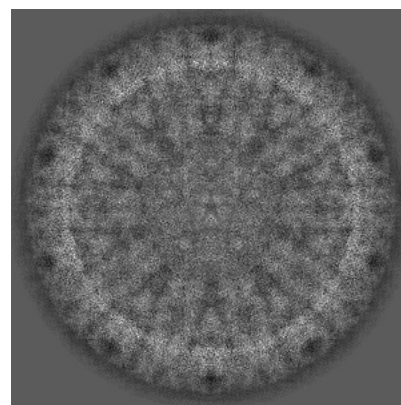

Z

The images above show the map projected in three orthogonal directions.

6.2 Central slices [i](#)

6.2.1 Primary map

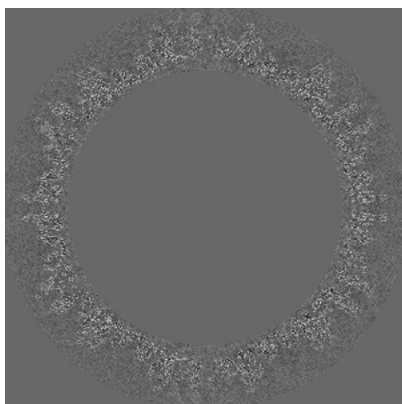

X Index: 640

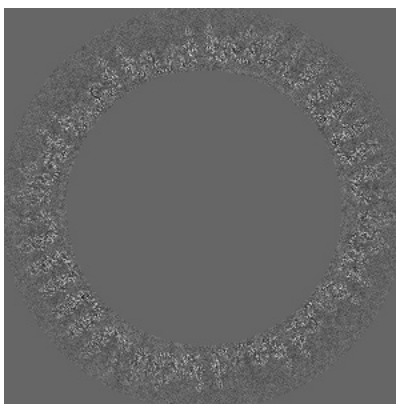

Y Index: 640

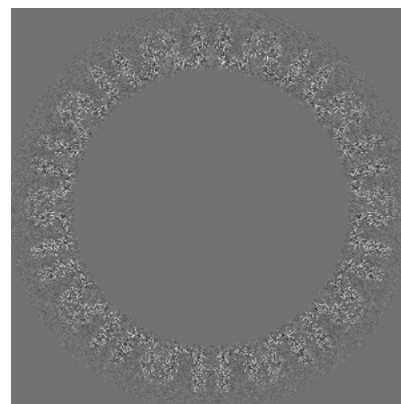

Z Index: 640

The images above show central slices of the map in three orthogonal directions.

6.3 Largest variance slices [i](#)

6.3.1 Primary map

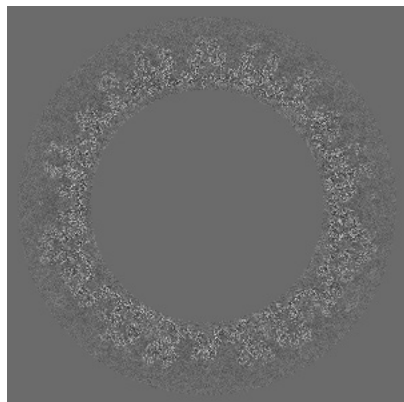

X Index: 405

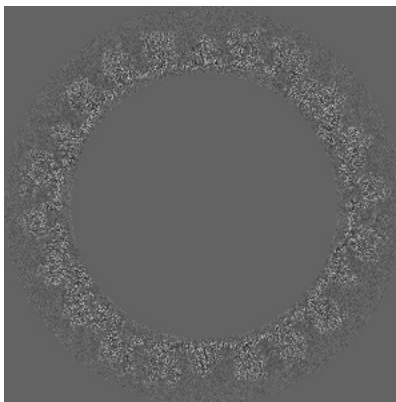

Y Index: 753

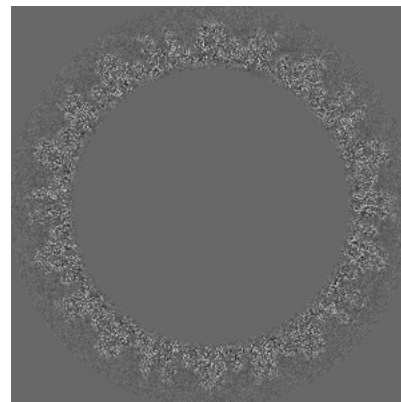

Z Index: 668

The images above show the largest variance slices of the map in three orthogonal directions.

6.4 Orthogonal standard-deviation projections (False-color) [i](#)

6.4.1 Primary map

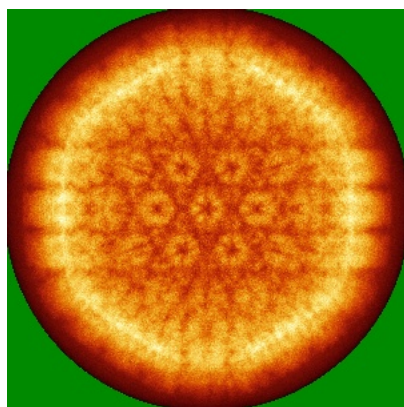

X

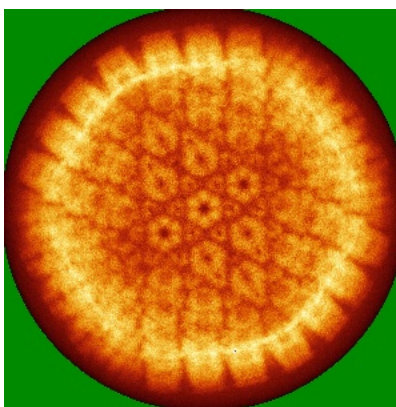

Y

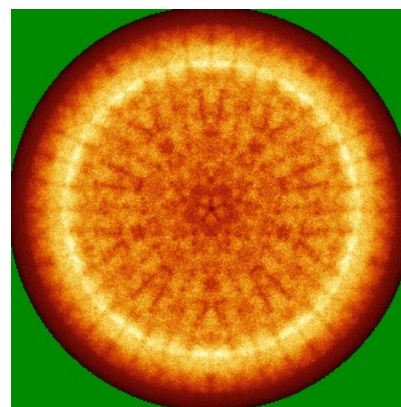

Z

The images above show the map standard deviation projections with false color in three orthogonal directions. Minimum values are shown in green, max in blue, and dark to light orange shades represent small to large values respectively.

6.5 Orthogonal surface views [i](#)

6.5.1 Primary map

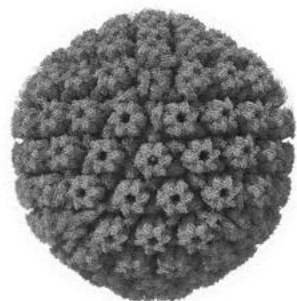

X

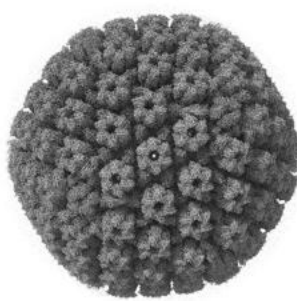

Y

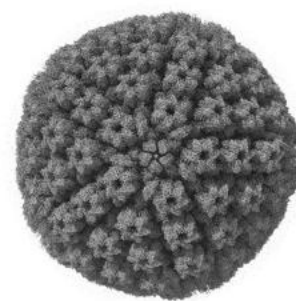

Z

The images above show the 3D surface view of the map at the recommended contour level 2.5. These images, in conjunction with the slice images, may facilitate assessment of whether an appropriate contour level has been provided.

6.6 Mask visualisation [i](#)

This section was not generated. No masks/segmentation were deposited.

7 Map analysis [i](#)

This section contains the results of statistical analysis of the map.

7.1 Map-value distribution [i](#)

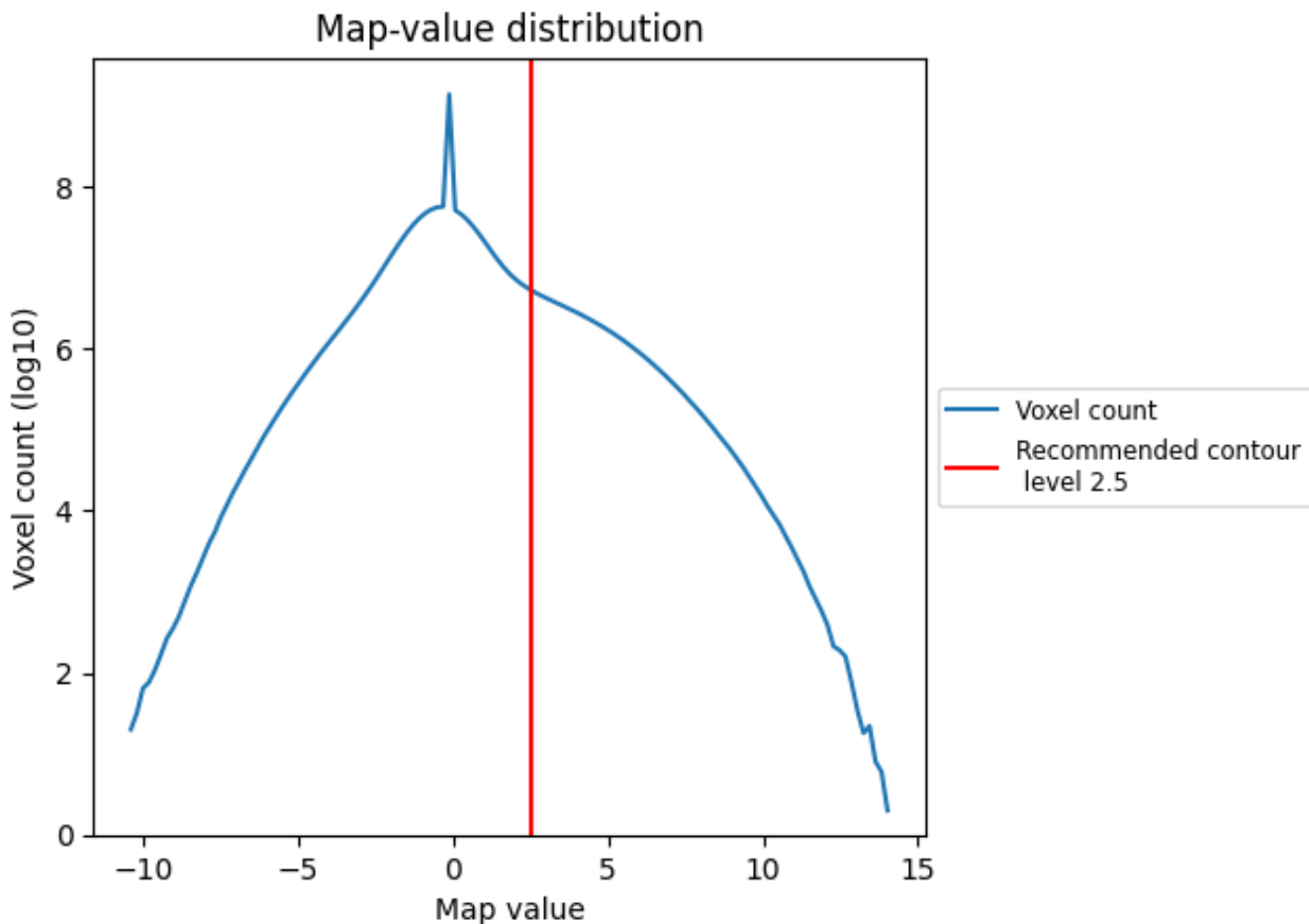

The map-value distribution is plotted in 128 intervals along the x-axis. The y-axis is logarithmic. A spike in this graph at zero usually indicates that the volume has been masked.

7.2 Volume estimate [i](#)

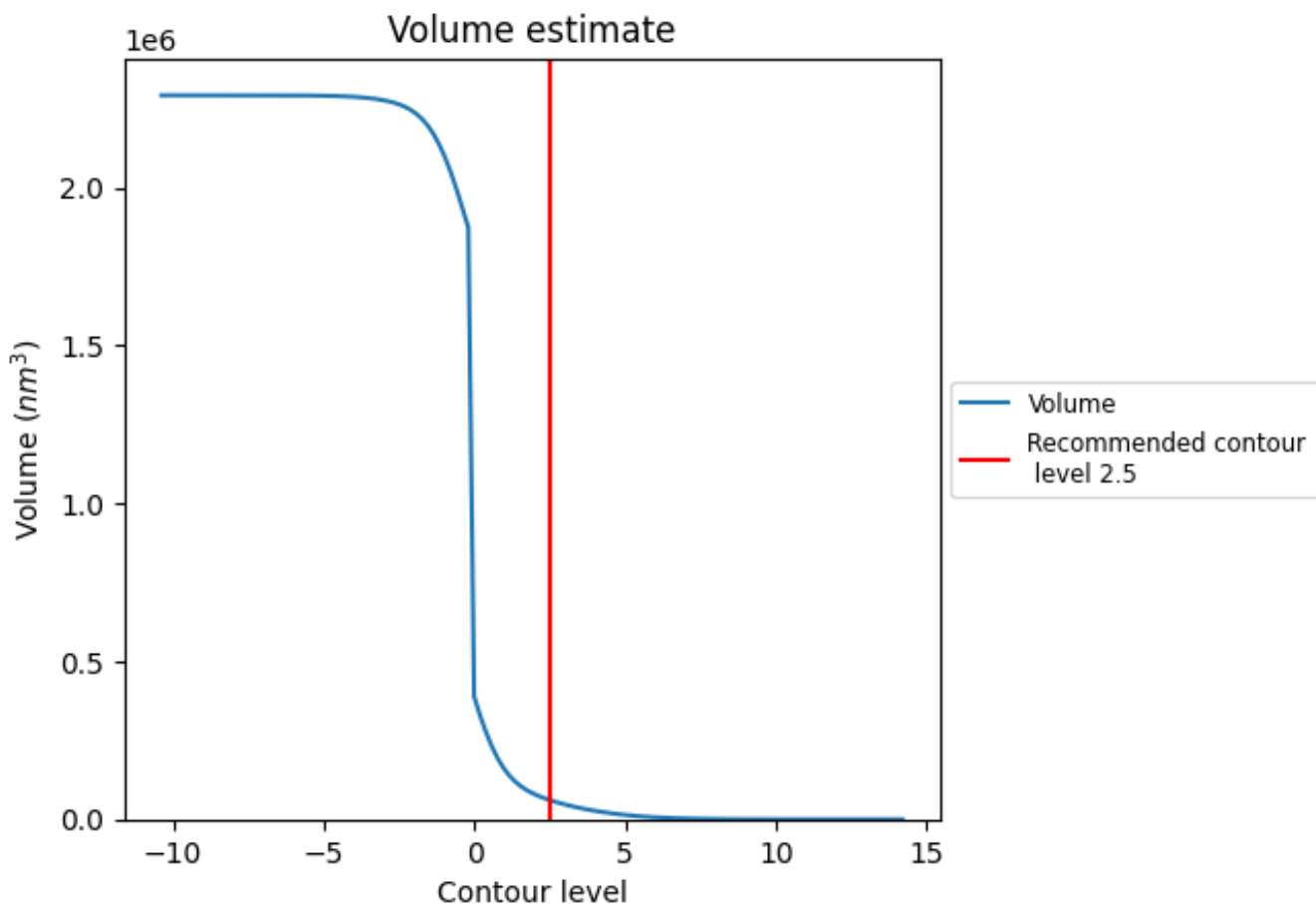

The volume at the recommended contour level is 60862 nm^3 ; this corresponds to an approximate mass of 54978 kDa.

The volume estimate graph shows how the enclosed volume varies with the contour level. The recommended contour level is shown as a vertical line and the intersection between the line and the curve gives the volume of the enclosed surface at the given level.

7.3 Rotationally averaged power spectrum [i](#)

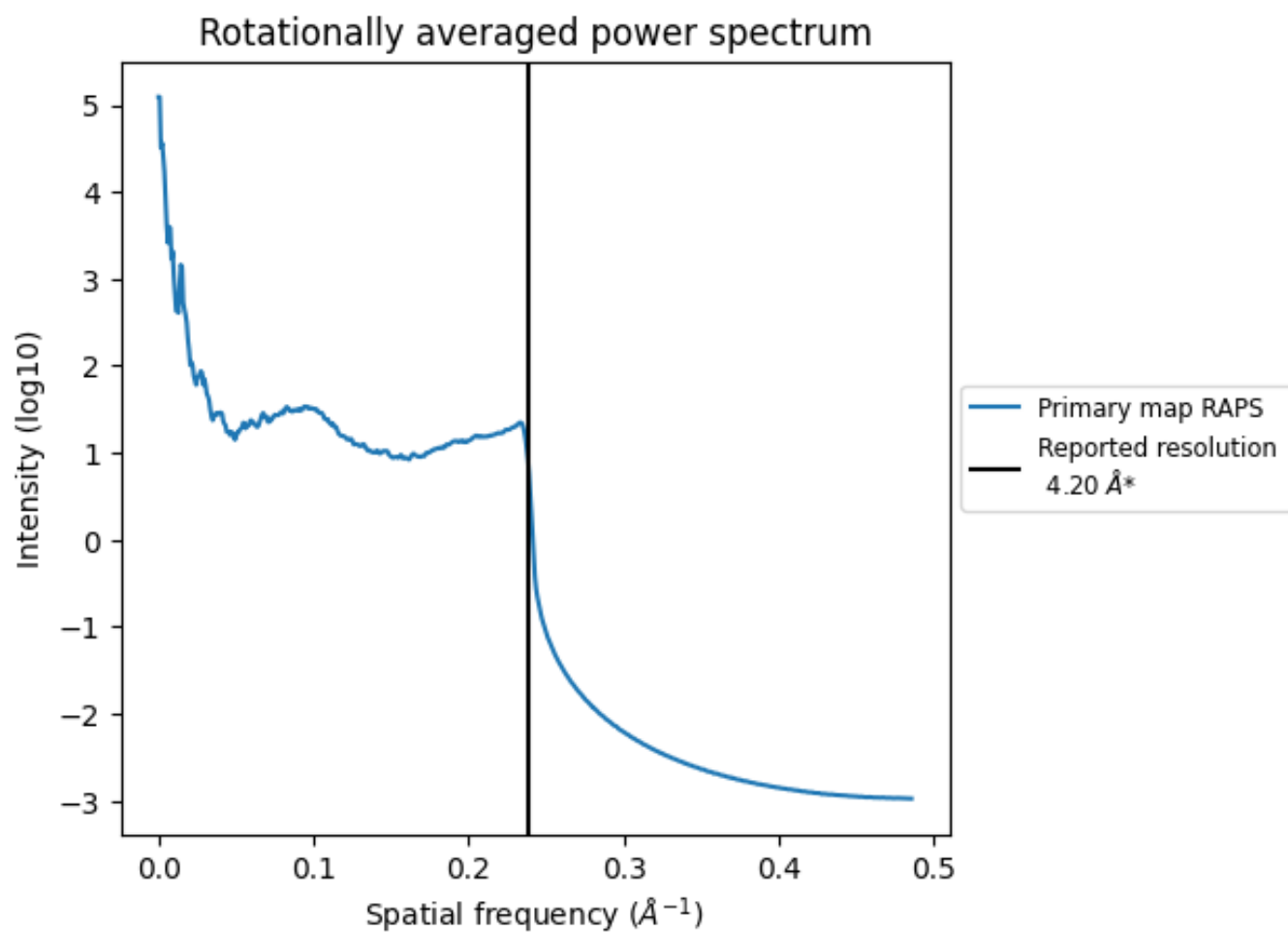

*Reported resolution corresponds to spatial frequency of 0.238\AA^{-1}

8 Fourier-Shell correlation

This section was not generated. No FSC curve or half-maps provided.

9 Map-model fit [i](#)

This section contains information regarding the fit between EMDB map EMD-7472 and PDB model 6CGR. Per-residue inclusion information can be found in section 3 on page 8.

9.1 Map-model overlays

9.1.1 Map-model overlay [i](#)

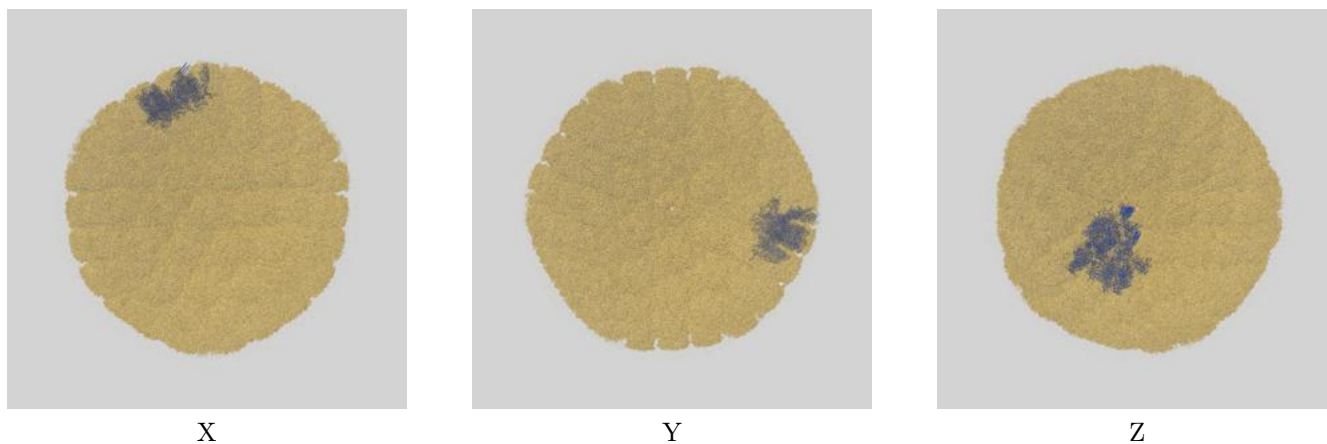

9.1.2 Map-model assembly overlay [i](#)

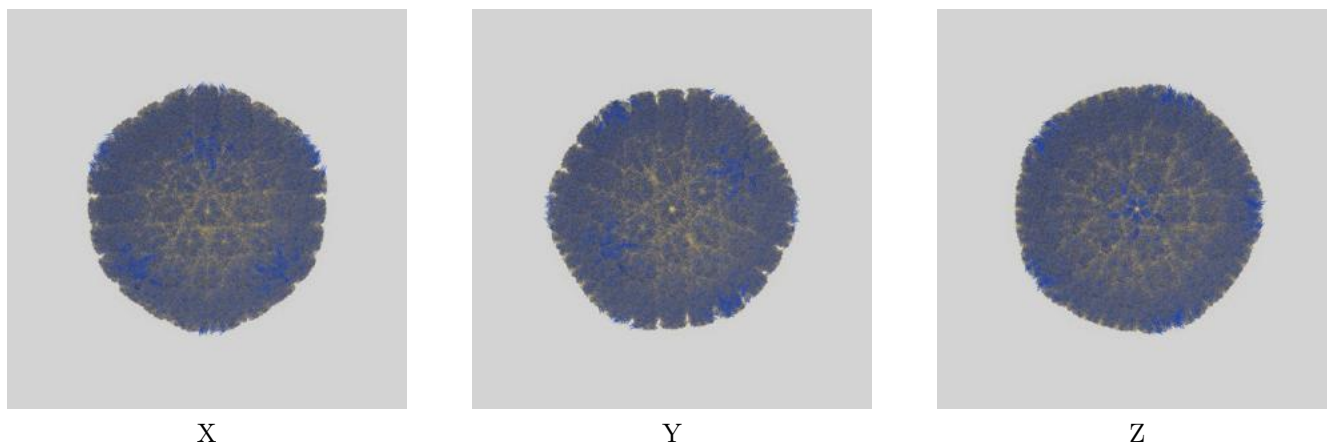

The images above show the 3D surface view of the map at the recommended contour level 2.5 at 50% transparency in yellow overlaid with a ribbon representation of the model coloured in blue. These images allow for the visual assessment of the quality of fit between the atomic model and the map.

9.2 Q-score mapped to coordinate model [i](#)

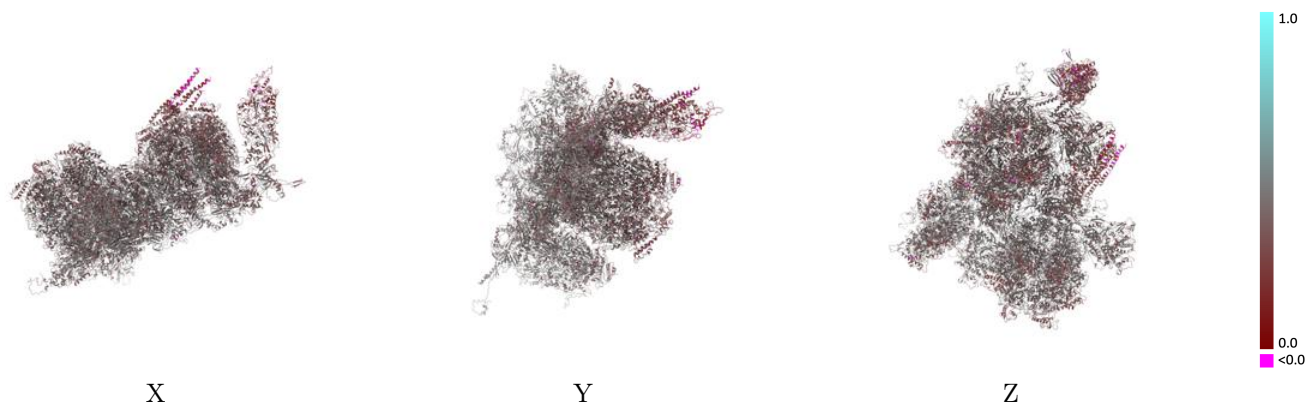

The images above show the model with each residue coloured according to its Q-score. This shows their resolvability in the map with higher Q-score values reflecting better resolvability. Please note: Q-score is calculating the resolvability of atoms, and thus high values are only expected at resolutions at which atoms can be resolved. Low Q-score values may therefore be expected for many entries.

9.3 Atom inclusion mapped to coordinate model [i](#)

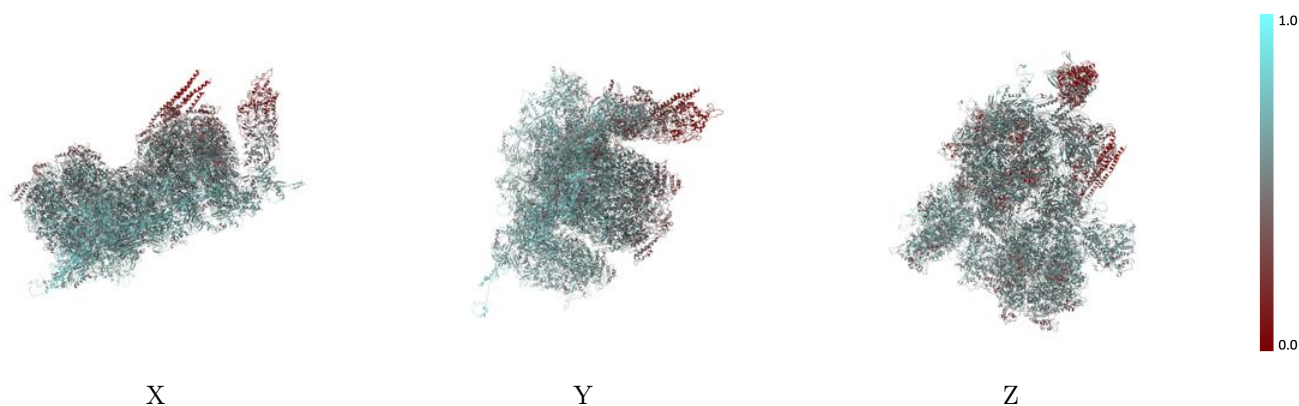

The images above show the model with each residue coloured according to its atom inclusion. This shows to what extent they are inside the map at the recommended contour level (2.5).



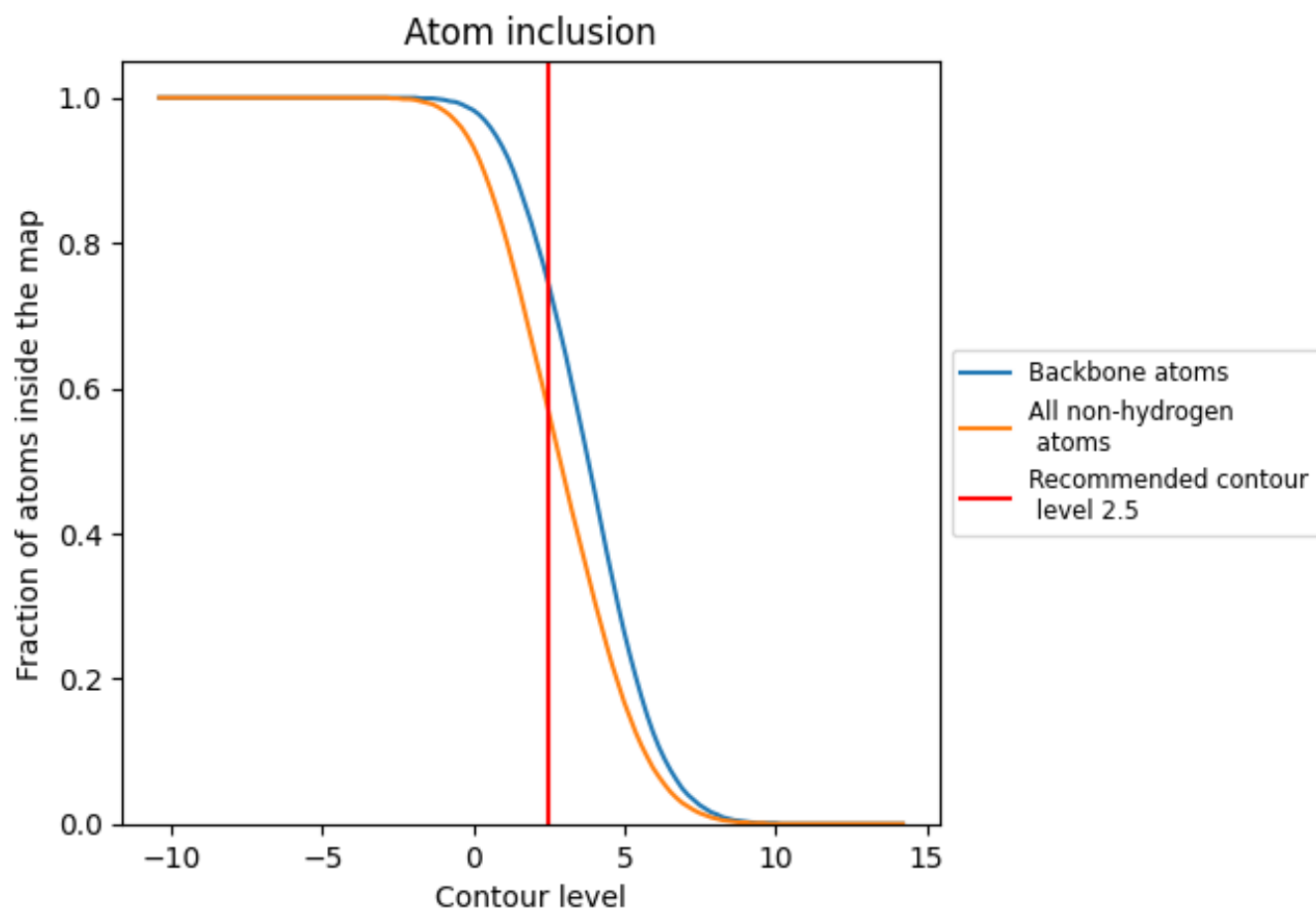



































































9.4 Atom inclusion [i](#)



At the recommended contour level, 74% of all backbone atoms, 57% of all non-hydrogen atoms, are inside the map.

9.5 Map-model fit summary



































The table lists the average atom inclusion at the recommended contour level (2.5) and Q-score for the entire model and for each chain.

Chain	Atom inclusion	Q-score
All	 0.5660	 0.3920
0	 0.3440	 0.3060
1	 0.3960	 0.3050
2	 0.3660	 0.2980
3	 0.3610	 0.3360
4	 0.3640	 0.3180
5	 0.5290	 0.3910
6	 0.4640	 0.3550
7	 0.4840	 0.3510
8	 0.6060	 0.4140
9	 0.6130	 0.4020
A	 0.6090	 0.4070
B	 0.6190	 0.4130
C	 0.6010	 0.4070
D	 0.6100	 0.4090
E	 0.6000	 0.4020
F	 0.6030	 0.4090
G	 0.4190	 0.3370
H	 0.4270	 0.3240
I	 0.4140	 0.3400
J	 0.4140	 0.3330
K	 0.3900	 0.2940
L	 0.3970	 0.3340
M	 0.6240	 0.4150
N	 0.6230	 0.4120
O	 0.6210	 0.4140
P	 0.4630	 0.3390
Q	 0.4550	 0.3590
R	 0.4910	 0.3630
S	 0.5520	 0.3880
T	 0.5600	 0.3780
U	 0.5930	 0.4070
V	 0.5960	 0.4050
W	 0.5800	 0.4020
X	 0.5510	 0.3820



Continued on next page...

Continued from previous page...

Chain	Atom inclusion	Q-score
Y	 0.3110	 0.3090
Z	 0.3270	 0.3010
a	 0.6110	 0.4070
b	 0.5830	 0.4050
c	 0.5900	 0.4000
d	 0.6170	 0.4090
e	 0.5700	 0.4090
f	 0.5810	 0.4000
g	 0.5710	 0.4010
h	 0.5930	 0.4080
i	 0.5880	 0.3950
j	 0.5950	 0.4030
k	 0.4470	 0.3600
l	 0.3140	 0.3060
m	 0.3390	 0.3010
n	 0.0900	 0.1410
o	 0.1530	 0.1920