



Full wwPDB EM Validation Report ⓘ

Mar 8, 2026 – 04:09 AM UTC

PDB ID : 7DN2 / pdb_00007dn2
EMDB ID : EMD-30778
Title : Acidic stable capsid structure of Helicobacter pylori bacteriophage KHP30
Authors : Kamiya, R.; Uchiyama, J.; Matsuzaki, S.; Murata, K.; Iwasaki, K.; Miyazaki, N.
Deposited on : 2020-12-08
Resolution : 2.70 Å(reported)

This is a Full wwPDB EM Validation Report for a publicly released PDB entry.

We welcome your comments at validation@mail.wwpdb.org

A user guide is available at

<https://www.wwpdb.org/validation/2017/EMValidationReportHelp>

with specific help available everywhere you see the ⓘ symbol.

The types of validation reports are described at

<http://www.wwpdb.org/validation/2017/FAQs#types>.

The following versions of software and data (see [references ⓘ](#)) were used in the production of this report:

EMDB validation analysis : 0.0.1.dev132
MolProbity : 4-5-2 with Phenix2.0
Percentile statistics : 20250101.v01 (using entries in the PDB archive January 1st 2025)
EM percentile statistics : 202505.v01 (Using data in the EMDB archive up until May 2025)
MapQ : 1.9.13
Ideal geometry (proteins) : Engh & Huber (2001)
Ideal geometry (DNA, RNA) : Parkinson et al. (1996)
Validation Pipeline (wwPDB-VP) : 2.49

1 Overall quality at a glance

The following experimental techniques were used to determine the structure:
ELECTRON MICROSCOPY

The reported resolution of this entry is 2.70 Å.

Percentile scores (ranging between 0-100) for global validation metrics of the entry are shown in the following graphic. The table shows the number of entries on which the scores are based.

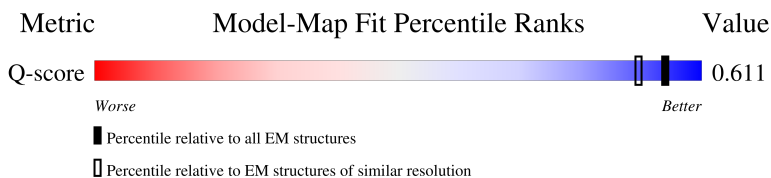
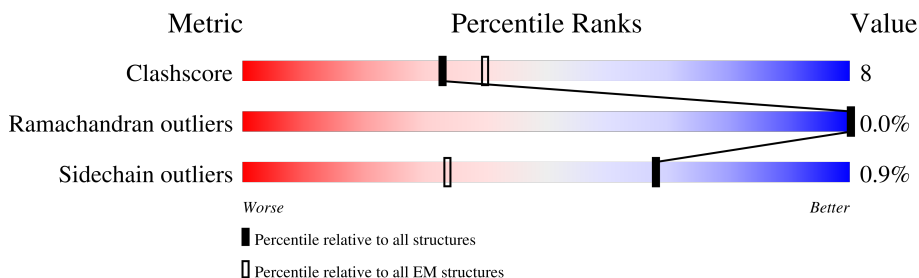

Metric	Whole archive (#Entries)	EM structures (#Entries)	Similar EM resolution (#Entries, resolution range(Å))
Clashscore	229148	23984	-
Ramachandran outliers	224038	23583	-
Sidechain outliers	223484	23102	-
Q-score	-	25397	10327 (2.20 - 3.20)

The table below summarises the geometric issues observed across the polymeric chains and their fit to the map. The red, orange, yellow and green segments of the bar indicate the fraction of residues that contain outliers for ≥ 3 , 2, 1 and 0 types of geometric quality criteria respectively. A grey segment represents the fraction of residues that are not modelled. The numeric value for each fraction is indicated below the corresponding segment, with a dot representing fractions $\leq 5\%$. The upper red bar (where present) indicates the fraction of residues that have poor fit to the EM map (all-atom inclusion $< 40\%$). The numeric value is given above the bar.

Mol	Chain	Length	Quality of chain
1	a	381	 73% 23%
1	b	381	 81% 15%
1	c	381	 76% 20%
1	d	381	 72% 24%

Continued on next page...

Continued from previous page...

Mol	Chain	Length	Quality of chain
1	e	381	 81% 16%
1	f	381	 80% 18%
1	g	381	 77% 20%
1	h	381	 76% 18% 5%
1	i	381	 9% 78% 16% 5%
2	1	126	 8% 81% 18%
2	2	126	 6% 85% 15%
2	3	126	 7% 78% 22%
2	4	126	 5% 75% 25%
2	5	126	 6% 77% 22%
2	6	126	 5% 77% 23%
2	7	126	 83% 17%
2	8	126	 6% 85% 15%
2	9	126	 7% 73% 26%

2 Entry composition [i](#)

There are 2 unique types of molecules in this entry. The entry contains 34503 atoms, of which 0 are hydrogens and 0 are deuteriums.

In the tables below, the AltConf column contains the number of residues with at least one atom in alternate conformation and the Trace column contains the number of residues modelled with at most 2 atoms.

- Molecule 1 is a protein called Major structural protein ORF14.

Mol	Chain	Residues	Atoms					AltConf	Trace
			Total	C	N	O	S		
1	a	368	Total 2870	C 1805	N 494	O 560	S 11	0	0
1	b	366	Total 2854	C 1797	N 490	O 556	S 11	0	0
1	c	368	Total 2870	C 1806	N 495	O 558	S 11	0	0
1	d	371	Total 2896	C 1822	N 498	O 565	S 11	0	0
1	e	370	Total 2887	C 1816	N 496	O 564	S 11	0	0
1	f	370	Total 2887	C 1816	N 496	O 564	S 11	0	0
1	g	370	Total 2888	C 1816	N 497	O 564	S 11	0	0
1	h	362	Total 2819	C 1772	N 485	O 551	S 11	0	0
1	i	362	Total 2838	C 1788	N 488	O 550	S 12	0	0

- Molecule 2 is a protein called Cement protein gp15.

Mol	Chain	Residues	Atoms					AltConf	Trace
			Total	C	N	O	S		
2	1	126	Total 966	C 615	N 157	O 193	S 1	0	0
2	2	126	Total 966	C 615	N 157	O 193	S 1	0	0
2	3	126	Total 966	C 615	N 157	O 193	S 1	0	0
2	4	126	Total 966	C 615	N 157	O 193	S 1	0	0
2	5	126	Total 966	C 615	N 157	O 193	S 1	0	0
2	6	126	Total 966	C 615	N 157	O 193	S 1	0	0

Continued on next page...

Continued from previous page...

Mol	Chain	Residues	Atoms					AltConf	Trace
			Total	C	N	O	S		
2	7	126	Total 966	615	157	193	1	0	0
2	8	126	Total 966	615	157	193	1	0	0
2	9	126	Total 966	615	157	193	1	0	0

3 Residue-property plots [i](#)

These plots are drawn for all protein, RNA, DNA and oligosaccharide chains in the entry. The first graphic for a chain summarises the proportions of the various outlier classes displayed in the second graphic. The second graphic shows the sequence view annotated by issues in geometry and atom inclusion in map density. Residues are color-coded according to the number of geometric quality criteria for which they contain at least one outlier: green = 0, yellow = 1, orange = 2 and red = 3 or more. A red diamond above a residue indicates a poor fit to the EM map for this residue (all-atom inclusion < 40%). Stretches of 2 or more consecutive residues without any outlier are shown as a green connector. Residues present in the sample, but not in the model, are shown in grey.

- Molecule 1: Major structural protein ORF14

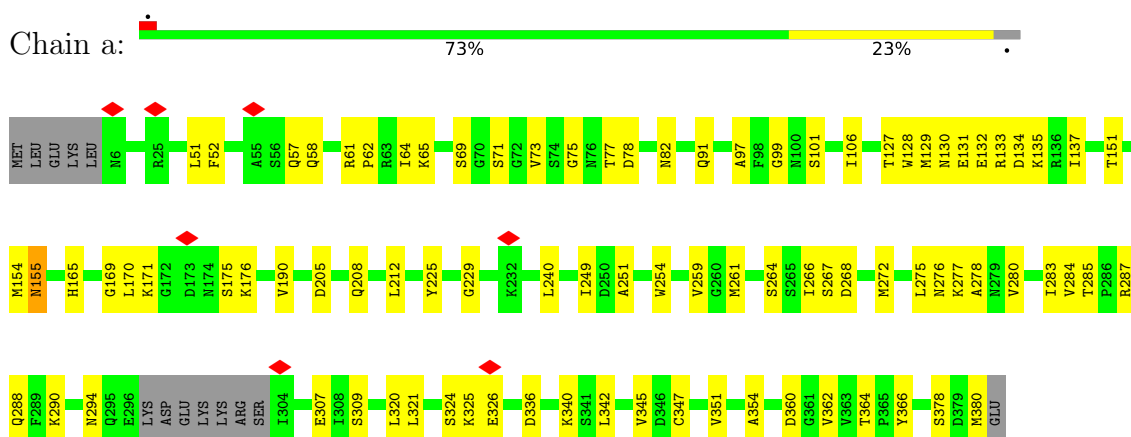

- Molecule 1: Major structural protein ORF14

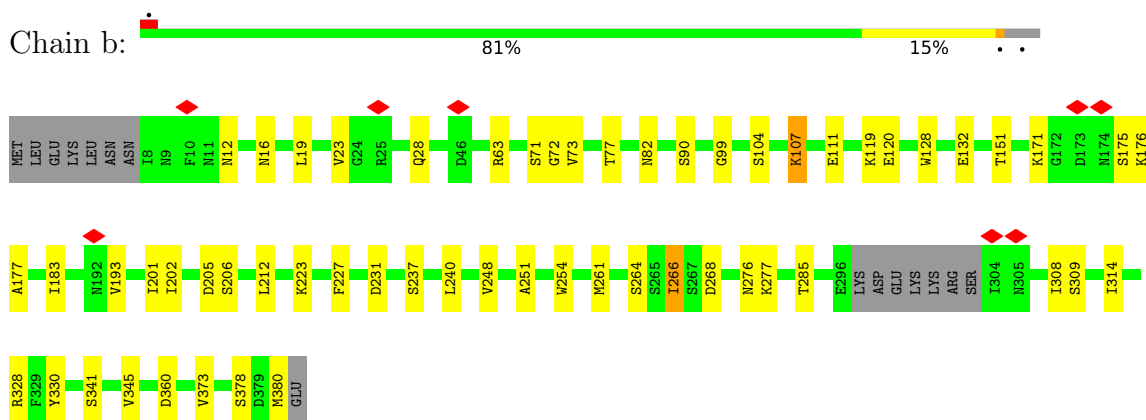

- Molecule 1: Major structural protein ORF14

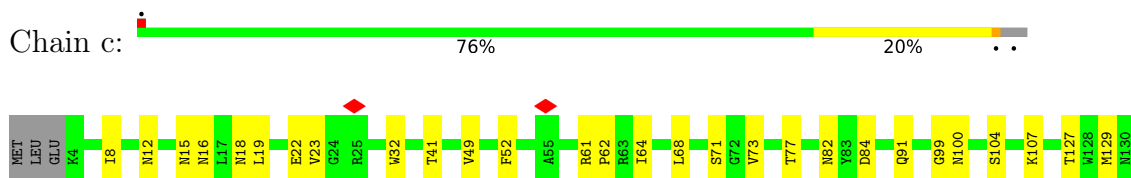

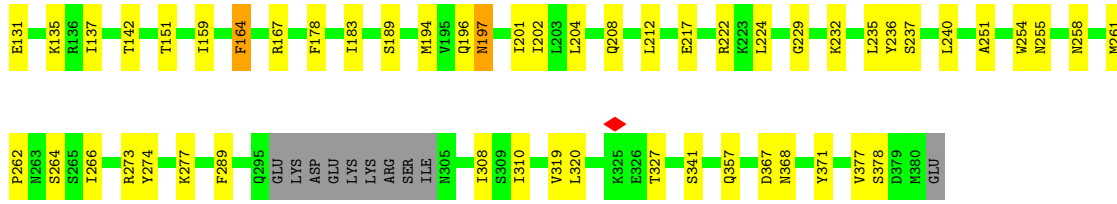

• Molecule 1: Major structural protein ORF14

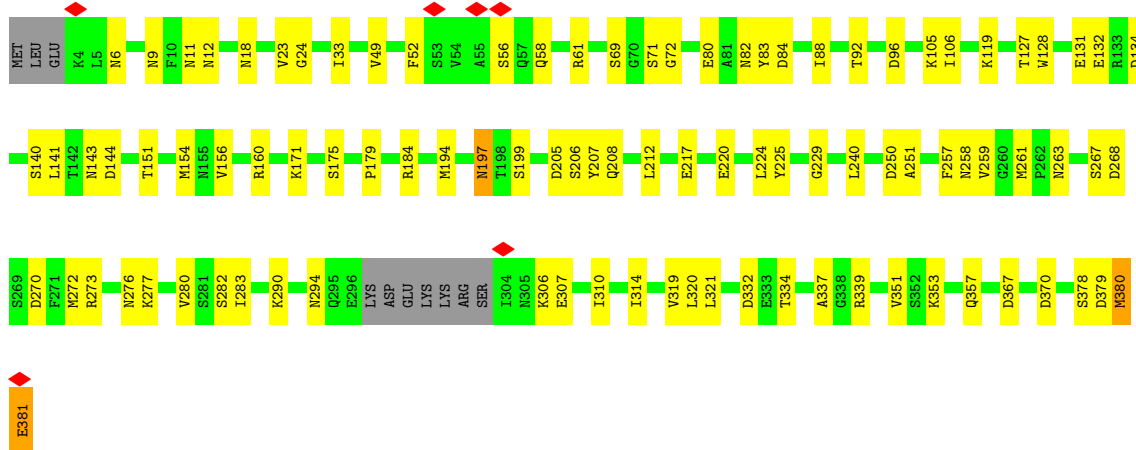

• Molecule 1: Major structural protein ORF14

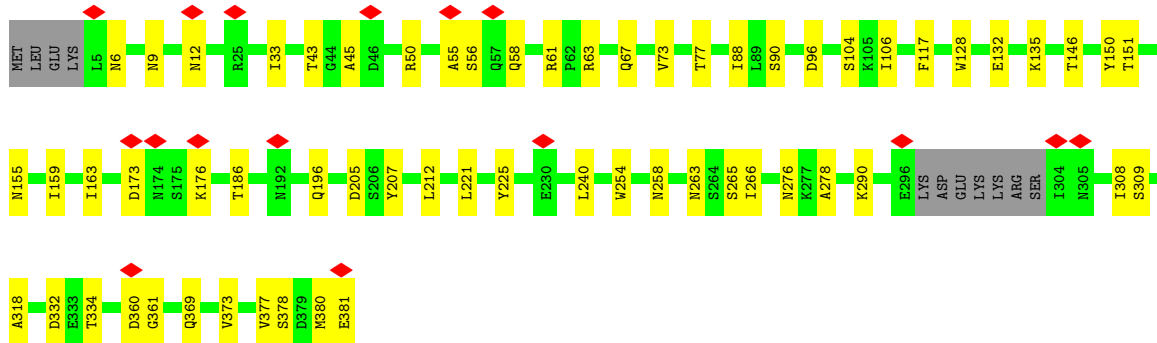
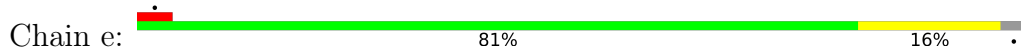

• Molecule 1: Major structural protein ORF14

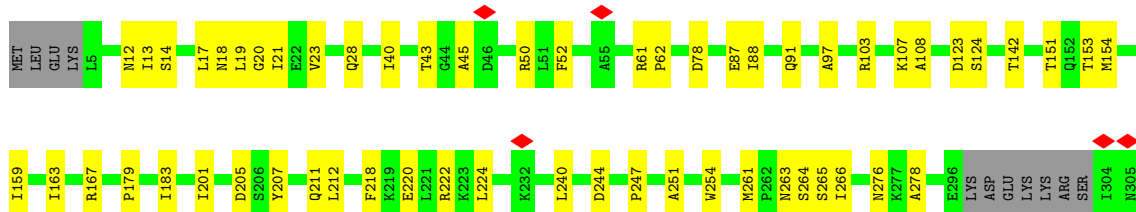
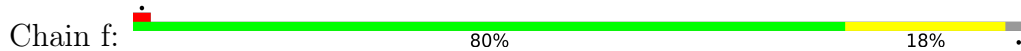

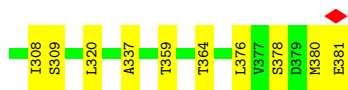

• Molecule 1: Major structural protein ORF14

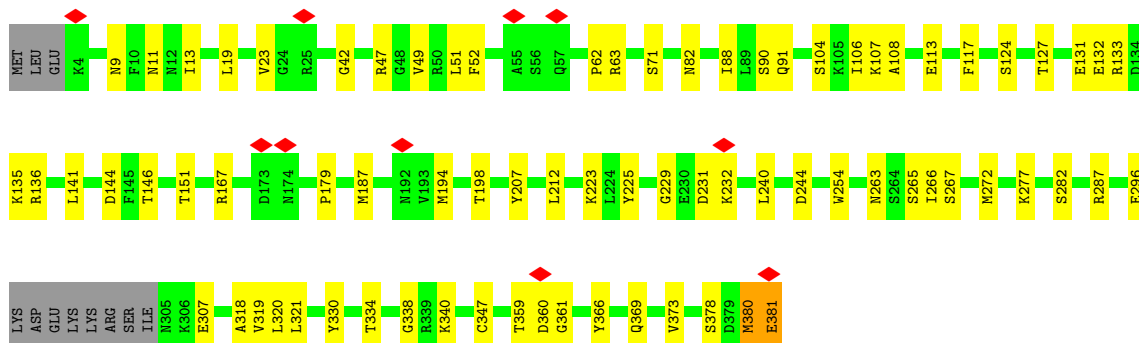
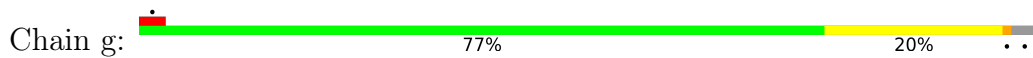

• Molecule 1: Major structural protein ORF14

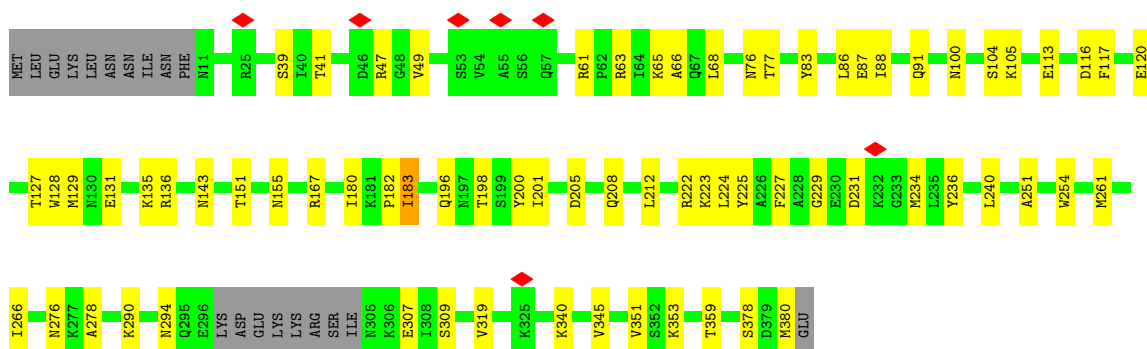
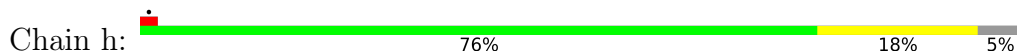

• Molecule 1: Major structural protein ORF14

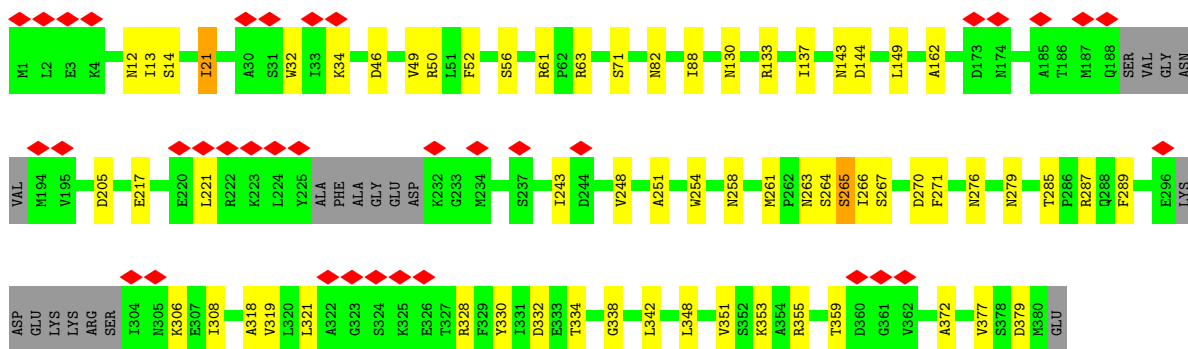
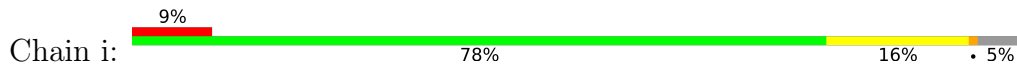

• Molecule 2: Cement protein gp15

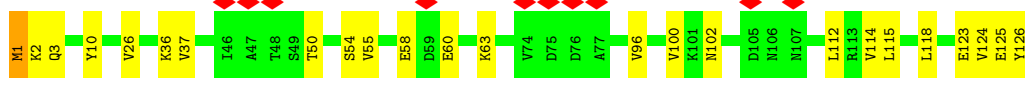
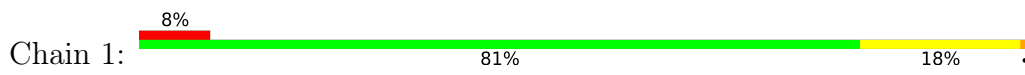

• Molecule 2: Cement protein gp15

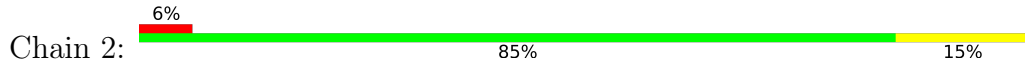

• Molecule 2: Cement protein gp15

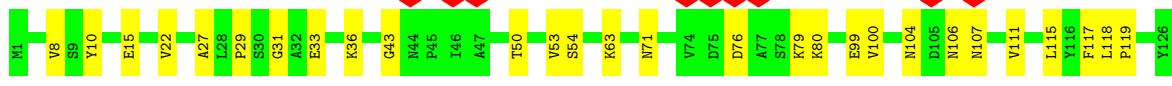
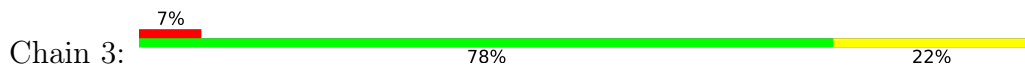

• Molecule 2: Cement protein gp15

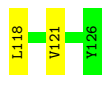
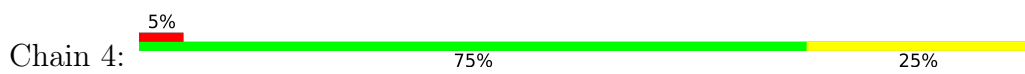

• Molecule 2: Cement protein gp15

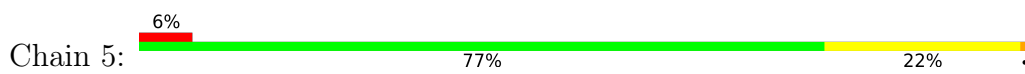

• Molecule 2: Cement protein gp15

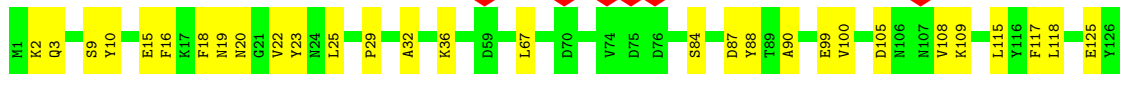
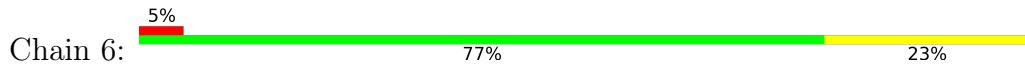

• Molecule 2: Cement protein gp15

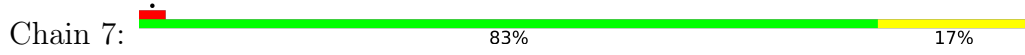

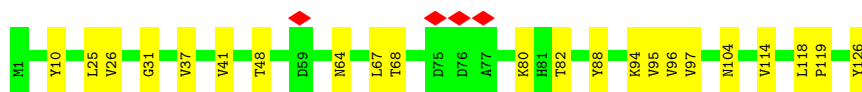

- Molecule 2: Cement protein gp15

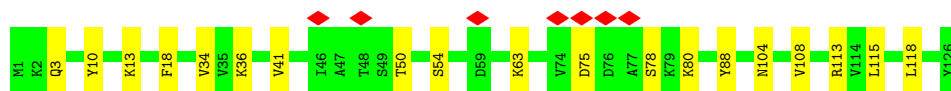
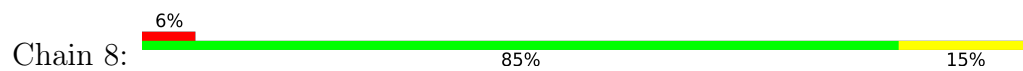

- Molecule 2: Cement protein gp15

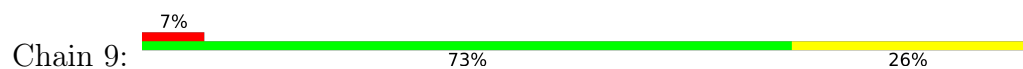

4 Experimental information

Property	Value	Source
EM reconstruction method	SINGLE PARTICLE	Depositor
Imposed symmetry	POINT, I	Depositor
Number of particles used	20737	Depositor
Resolution determination method	FSC 0.143 CUT-OFF	Depositor
CTF correction method	PHASE FLIPPING AND AMPLITUDE CORRECTION	Depositor
Microscope	FEI TITAN KRIOS	Depositor
Voltage (kV)	300	Depositor
Electron dose ($e^-/\text{\AA}^2$)	20.0	Depositor
Minimum defocus (nm)	Not provided	
Maximum defocus (nm)	Not provided	
Magnification	Not provided	
Image detector	FEI FALCON II (4k x 4k)	Depositor
Maximum map value	0.214	Depositor
Minimum map value	-0.096	Depositor
Average map value	0.001	Depositor
Map value standard deviation	0.008	Depositor
Recommended contour level	0.027	Depositor
Map size (Å)	870.0, 870.0, 870.0	wwPDB
Map dimensions	750, 750, 750	wwPDB
Map angles (°)	90.0, 90.0, 90.0	wwPDB
Pixel spacing (Å)	1.16, 1.16, 1.16	Depositor

5 Model quality [i](#)

5.1 Standard geometry [i](#)

The Z score for a bond length (or angle) is the number of standard deviations the observed value is removed from the expected value. A bond length (or angle) with $|Z| > 5$ is considered an outlier worth inspection. RMSZ is the root-mean-square of all Z scores of the bond lengths (or angles).

Mol	Chain	Bond lengths		Bond angles	
		RMSZ	# Z >5	RMSZ	# Z >5
1	a	0.32	0/2916	0.44	0/3939
1	b	0.32	0/2900	0.44	0/3917
1	c	0.35	0/2916	0.46	0/3938
1	d	0.36	0/2942	0.49	0/3973
1	e	0.37	0/2933	0.51	0/3962
1	f	0.36	0/2933	0.49	0/3962
1	g	0.35	0/2934	0.51	0/3962
1	h	0.34	0/2864	0.47	0/3868
1	i	0.34	0/2881	0.47	0/3886
2	1	0.29	0/981	0.41	0/1334
2	2	0.25	0/981	0.36	0/1334
2	3	0.27	0/981	0.36	0/1334
2	4	0.30	0/981	0.42	0/1334
2	5	0.25	0/981	0.35	0/1334
2	6	0.25	0/981	0.37	0/1334
2	7	0.27	0/981	0.36	0/1334
2	8	0.26	0/981	0.37	0/1334
2	9	0.35	0/981	0.49	0/1334
All	All	0.33	0/35048	0.46	0/47413

There are no bond length outliers.

There are no bond angle outliers.

There are no chirality outliers.

There are no planarity outliers.

5.2 Too-close contacts [i](#)

In the following table, the Non-H and H(model) columns list the number of non-hydrogen atoms and hydrogen atoms in the chain respectively. The H(added) column lists the number of hydrogen atoms added and optimized by MolProbity. The Clashes column lists the number of clashes within the asymmetric unit, whereas Symm-Clashes lists symmetry-related clashes.

Mol	Chain	Non-H	H(model)	H(added)	Clashes	Symm-Clashes
1	a	2870	0	2850	63	0
1	b	2854	0	2838	44	0
1	c	2870	0	2857	62	0
1	d	2896	0	2880	66	0
1	e	2887	0	2867	44	0
1	f	2887	0	2867	53	0
1	g	2888	0	2868	68	0
1	h	2819	0	2801	52	0
1	i	2838	0	2837	41	0
2	1	966	0	976	20	0
2	2	966	0	976	10	0
2	3	966	0	976	16	0
2	4	966	0	976	20	0
2	5	966	0	976	18	0
2	6	966	0	976	18	0
2	7	966	0	976	13	0
2	8	966	0	976	11	0
2	9	966	0	976	20	0
All	All	34503	0	34449	579	0

The all-atom clashscore is defined as the number of clashes found per 1000 atoms (including hydrogen atoms). The all-atom clashscore for this structure is 8.

All (579) close contacts within the same asymmetric unit are listed below, sorted by their clash magnitude.

Atom-1	Atom-2	Interatomic distance (Å)	Clash overlap (Å)
1:g:207:TYR:CE1	1:g:380:MET:HE1	1.33	1.60
1:g:207:TYR:CE1	1:g:380:MET:CE	2.15	1.28
1:g:263:ASN:OD1	1:g:265:SER:OG	1.52	1.22
2:9:70:ASP:O	2:9:79:LYS:HE2	1.46	1.13
1:g:207:TYR:CZ	1:g:380:MET:HE1	1.86	1.09
1:g:207:TYR:CD1	1:g:380:MET:CE	2.36	1.07
1:g:207:TYR:CD1	1:g:380:MET:HE1	2.02	0.92
1:e:309:SER:HB2	1:e:380:MET:HB3	1.52	0.90
1:g:207:TYR:CZ	1:g:380:MET:CE	2.52	0.89
1:d:207:TYR:CD2	1:d:380:MET:O	2.32	0.83
1:i:267:SER:HA	1:i:287:ARG:HE	1.45	0.82
1:g:207:TYR:CD2	1:g:380:MET:O	2.34	0.81
1:f:207:TYR:HD1	1:f:381:GLU:HG3	1.47	0.79
1:h:205:ASP:HB3	1:h:261:MET:HB2	1.64	0.79
2:4:49:SER:HA	2:4:104:ASN:HD21	1.48	0.78
1:b:254:TRP:CD1	1:b:266:ILE:CD1	2.67	0.78

Continued on next page...

Continued from previous page...

Atom-1	Atom-2	Interatomic distance (Å)	Clash overlap (Å)
2:9:41:VAL:O	2:9:80:LYS:HD2	1.86	0.76
1:g:207:TYR:CD1	1:g:380:MET:HE3	2.22	0.75
1:b:205:ASP:HB3	1:b:261:MET:HB2	1.68	0.74
1:a:364:THR:HG22	1:a:366:TYR:H	1.53	0.74
1:g:104:SER:HB2	1:g:117:PHE:CD2	2.23	0.73
1:e:45:ALA:HA	1:e:50:ARG:HD2	1.71	0.72
1:a:71:SER:O	1:a:82:ASN:ND2	2.23	0.71
1:f:207:TYR:CD1	1:f:381:GLU:HG3	2.26	0.71
1:h:212:LEU:HD23	1:h:240:LEU:HD22	1.73	0.71
2:8:13:LYS:HG3	2:8:113:ARG:HG2	1.73	0.71
1:g:144:ASP:OD2	1:g:282:SER:OG	2.09	0.70
1:b:205:ASP:OD2	1:b:309:SER:OG	2.09	0.70
2:5:13:LYS:HG3	2:5:113:ARG:HG2	1.73	0.70
1:g:229:GLY:HA2	1:g:232:LYS:HE3	1.74	0.70
1:e:12:ASN:HB2	2:1:2:LYS:CE	2.21	0.70
1:f:45:ALA:HA	1:f:50:ARG:HD2	1.73	0.70
1:h:205:ASP:OD2	1:h:309:SER:OG	2.10	0.70
1:e:380:MET:HG3	1:e:380:MET:O	1.92	0.70
1:c:289:PHE:HE2	1:c:377:VAL:HG21	1.57	0.69
1:d:212:LEU:HD23	1:d:240:LEU:HD22	1.74	0.69
2:5:74:VAL:HG23	2:5:75:ASP:H	1.57	0.69
1:e:12:ASN:HB2	2:1:2:LYS:HE3	1.74	0.68
1:b:328:ARG:NH1	1:b:330:TYR:OH	2.26	0.68
1:c:212:LEU:HD23	1:c:240:LEU:HD22	1.75	0.68
2:4:15:GLU:HG3	2:4:111:VAL:HG22	1.75	0.68
1:d:290:LYS:NZ	1:d:307:GLU:OE1	2.27	0.68
1:a:272:MET:O	1:a:277:LYS:NZ	2.26	0.67
1:f:207:TYR:CE2	1:f:380:MET:CE	2.78	0.67
1:e:63:ARG:HG2	1:e:90:SER:HB3	1.76	0.67
1:g:52:PHE:HE2	1:g:320:LEU:HD22	1.60	0.67
2:4:37:VAL:HG22	2:4:114:VAL:HG22	1.77	0.66
1:c:16:ASN:HD22	1:c:19:LEU:HG	1.61	0.66
1:c:129:MET:HG2	1:c:327:THR:HG21	1.77	0.66
2:3:22:VAL:HG12	2:3:99:GLU:HB3	1.78	0.66
1:g:307:GLU:HB2	1:g:380:MET:HG3	1.77	0.65
2:6:29:PRO:HG2	2:6:32:ALA:HB2	1.78	0.65
1:h:104:SER:HB3	1:h:117:PHE:CE2	2.32	0.65
2:9:71:ASN:HB3	2:9:74:VAL:HG23	1.78	0.65
1:c:71:SER:O	1:c:82:ASN:ND2	2.30	0.65
1:g:207:TYR:HB3	1:g:380:MET:O	1.97	0.65
1:i:137:ILE:HD11	1:i:321:LEU:HD11	1.80	0.64

Continued on next page...

Continued from previous page...

Atom-1	Atom-2	Interatomic distance (Å)	Clash overlap (Å)
2:3:15:GLU:HG2	2:3:111:VAL:HG22	1.79	0.64
1:d:18:ASN:OD1	1:g:63:ARG:NH2	2.31	0.63
1:b:254:TRP:CD1	1:b:266:ILE:HD11	2.32	0.63
1:i:289:PHE:HE2	1:i:377:VAL:HG21	1.63	0.63
1:d:307:GLU:O	1:d:380:MET:N	2.31	0.63
2:1:58:GLU:HA	2:1:63:LYS:HE3	1.81	0.63
1:b:254:TRP:CG	1:b:266:ILE:HD11	2.34	0.63
2:2:49:SER:HA	2:2:104:ASN:HD21	1.62	0.62
1:b:104:SER:HB3	1:b:341:SER:H	1.65	0.62
1:f:18:ASN:OD1	1:i:63:ARG:NH2	2.30	0.62
1:f:207:TYR:CD2	1:f:380:MET:CE	2.83	0.62
1:b:28:GLN:HG2	1:c:64:ILE:HG22	1.82	0.62
1:d:332:ASP:OD1	1:d:334:THR:OG1	2.18	0.62
1:g:207:TYR:CG	1:g:380:MET:O	2.53	0.62
2:7:41:VAL:HB	2:7:80:LYS:HD3	1.82	0.62
1:i:71:SER:O	1:i:82:ASN:ND2	2.33	0.61
2:9:49:SER:HA	2:9:104:ASN:HD21	1.64	0.61
1:g:296:GLU:N	1:g:296:GLU:OE1	2.33	0.61
1:c:254:TRP:HB3	1:c:266:ILE:HD11	1.82	0.61
1:c:264:SER:HB2	1:c:308:ILE:HG12	1.83	0.61
1:d:144:ASP:OD1	1:d:282:SER:OG	2.17	0.61
2:3:43:GLY:O	2:3:80:LYS:NZ	2.34	0.61
1:a:254:TRP:CD1	1:a:266:ILE:HD12	2.36	0.61
1:i:21:ILE:HG22	1:i:21:ILE:O	2.00	0.61
1:d:71:SER:O	1:d:82:ASN:ND2	2.34	0.60
1:a:212:LEU:HD23	1:a:240:LEU:HD22	1.83	0.60
1:g:212:LEU:HD23	1:g:240:LEU:HD22	1.84	0.60
1:g:267:SER:HA	1:g:287:ARG:HH11	1.65	0.60
1:i:88:ILE:O	1:i:359:THR:HG23	2.02	0.60
1:f:205:ASP:HB3	1:f:261:MET:HB2	1.83	0.60
2:7:95:VAL:HG12	2:7:97:VAL:HG23	1.82	0.60
1:b:12:ASN:HD21	1:c:277:LYS:HB2	1.67	0.59
1:g:23:VAL:HG12	1:h:61:ARG:HD2	1.83	0.59
1:g:104:SER:HB2	1:g:117:PHE:CE2	2.37	0.59
1:g:272:MET:O	1:g:277:LYS:NZ	2.35	0.59
1:f:154:MET:HE1	1:f:376:LEU:HD22	1.84	0.59
2:9:42:VAL:HB	2:9:109:LYS:HG3	1.83	0.59
1:a:155:ASN:OD1	1:a:155:ASN:N	2.35	0.59
1:f:207:TYR:CE1	1:f:381:GLU:OE2	2.56	0.59
1:b:254:TRP:CD1	1:b:266:ILE:HD13	2.37	0.59
1:d:49:VAL:HG22	1:d:319:VAL:HG22	1.85	0.59

Continued on next page...

Continued from previous page...

Atom-1	Atom-2	Interatomic distance (Å)	Clash overlap (Å)
1:e:254:TRP:CD1	1:e:266:ILE:HD13	2.37	0.59
1:c:73:VAL:HG22	1:c:77:THR:HB	1.85	0.58
1:g:124:SER:HB3	1:h:68:LEU:HD22	1.84	0.58
1:h:83:TYR:H	2:9:120:SER:HB3	1.68	0.58
1:h:167:ARG:NH1	1:h:196:GLN:O	2.34	0.58
2:5:37:VAL:HG22	2:5:114:VAL:HG22	1.84	0.58
1:i:334:THR:HA	1:i:338:GLY:HA2	1.85	0.58
1:f:153:THR:HG23	1:f:211:GLN:HB3	1.85	0.58
1:g:381:GLU:CD	1:g:381:GLU:H	2.08	0.58
1:i:251:ALA:HB3	1:i:261:MET:HG2	1.86	0.58
1:h:105:LYS:NZ	1:h:113:GLU:OE1	2.36	0.57
1:h:251:ALA:HB3	1:h:261:MET:HG2	1.87	0.57
1:b:251:ALA:HB3	1:b:261:MET:HG2	1.87	0.57
1:g:207:TYR:CZ	1:g:380:MET:HE2	2.40	0.57
1:f:205:ASP:OD2	1:f:309:SER:OG	2.15	0.57
2:7:37:VAL:HG22	2:7:114:VAL:HG22	1.86	0.57
1:a:290:LYS:O	1:a:294:ASN:HB2	2.03	0.57
1:f:40:ILE:HD12	1:f:201:ILE:HD13	1.86	0.57
1:h:104:SER:HB3	1:h:117:PHE:CD2	2.39	0.57
1:g:71:SER:O	1:g:82:ASN:ND2	2.38	0.57
2:1:2:LYS:HB3	2:1:125:GLU:HG2	1.86	0.57
1:c:254:TRP:CD1	1:c:266:ILE:HD13	2.39	0.56
1:i:205:ASP:HB3	1:i:261:MET:HB2	1.87	0.56
1:i:254:TRP:HB3	1:i:266:ILE:HD11	1.87	0.56
2:8:75:ASP:OD1	2:8:78:SER:N	2.28	0.56
2:8:18:PHE:HD2	2:8:108:VAL:HG13	1.70	0.56
2:6:19:ASN:O	2:6:23:TYR:OH	2.20	0.56
1:e:6:ASN:HD21	2:1:3:GLN:HG2	1.71	0.56
2:7:31:GLY:HA3	2:7:119:PRO:HB3	1.87	0.56
1:e:332:ASP:OD1	1:e:334:THR:OG1	2.23	0.56
1:f:212:LEU:HD23	1:f:240:LEU:HD22	1.88	0.56
1:a:259:VAL:O	1:a:259:VAL:HG22	2.06	0.56
2:6:15:GLU:OE1	2:6:15:GLU:N	2.38	0.56
1:d:24:GLY:N	1:e:61:ARG:O	2.34	0.56
2:9:55:VAL:HB	2:9:67:LEU:HB2	1.88	0.56
1:a:130:ASN:OD1	1:a:133:ARG:NH2	2.39	0.55
1:b:63:ARG:HG2	1:b:90:SER:HB3	1.89	0.55
1:e:56:SER:O	1:e:58:GLN:N	2.39	0.55
1:g:63:ARG:HG2	1:g:90:SER:HB3	1.87	0.55
1:g:207:TYR:CG	1:g:380:MET:CE	2.89	0.55
1:h:183:ILE:HD13	1:h:201:ILE:HG13	1.88	0.55

Continued on next page...

Continued from previous page...

Atom-1	Atom-2	Interatomic distance (Å)	Clash overlap (Å)
1:f:123:ASP:OD1	1:f:124:SER:N	2.39	0.55
1:g:223:LYS:HG2	1:h:224:LEU:HD21	1.87	0.55
2:4:58:GLU:HG2	2:4:95:VAL:HB	1.89	0.55
1:a:280:VAL:HG11	1:a:283:ILE:HD13	1.89	0.55
2:1:36:LYS:HB3	2:1:115:LEU:HB3	1.88	0.55
2:9:19:ASN:O	2:9:23:TYR:OH	2.19	0.55
1:a:65:LYS:NZ	1:f:123:ASP:OD1	2.40	0.55
1:d:12:ASN:HB2	1:e:278:ALA:HB2	1.88	0.55
2:2:51:THR:HB	2:2:103:ALA:HA	1.89	0.55
1:a:309:SER:HB2	1:a:380:MET:HB3	1.89	0.55
1:d:33:ILE:HA	1:e:196:GLN:HE22	1.72	0.55
1:f:263:ASN:ND2	1:f:265:SER:OG	2.40	0.55
1:g:88:ILE:O	1:g:359:THR:HG23	2.06	0.55
1:a:135:LYS:HD3	1:a:254:TRP:CZ2	2.42	0.55
1:g:49:VAL:HG22	1:g:319:VAL:HB	1.88	0.55
1:h:49:VAL:HG13	1:h:319:VAL:HG23	1.88	0.55
2:8:50:THR:HG22	2:8:104:ASN:HD21	1.72	0.55
1:a:134:ASP:HB3	1:a:259:VAL:HG21	1.89	0.54
1:c:23:VAL:HA	1:d:61:ARG:HB3	1.90	0.54
1:f:207:TYR:CE2	1:f:380:MET:HE2	2.42	0.54
1:g:318:ALA:HB1	1:g:373:VAL:HG23	1.90	0.54
1:h:39:SER:O	1:h:47:ARG:NH1	2.40	0.54
1:h:100:ASN:HB2	1:h:128:TRP:CZ3	2.43	0.54
1:g:207:TYR:CE2	1:g:380:MET:HE2	2.42	0.54
2:2:8:VAL:HG12	2:2:118:LEU:HD23	1.89	0.54
2:7:88:TYR:OH	2:7:94:LYS:NZ	2.39	0.54
1:a:225:TYR:O	1:a:229:GLY:N	2.41	0.54
1:i:263:ASN:OD1	1:i:265:SER:HB2	2.07	0.54
2:8:41:VAL:HG22	2:8:80:LYS:HA	1.89	0.54
2:4:25:LEU:O	2:5:3:GLN:NE2	2.41	0.54
2:4:53:VAL:HG22	2:4:100:VAL:HG22	1.90	0.54
1:b:360:ASP:OD1	1:b:360:ASP:N	2.40	0.54
1:a:190:VAL:O	1:f:247:PRO:HB3	2.08	0.53
1:b:175:SER:OG	1:b:176:LYS:N	2.41	0.53
1:i:321:LEU:HD22	1:i:351:VAL:HG22	1.90	0.53
1:f:251:ALA:HB3	1:f:261:MET:HG2	1.90	0.53
1:h:182:PRO:HG3	1:h:198:THR:HB	1.90	0.53
1:i:46:ASP:OD1	1:i:46:ASP:N	2.40	0.53
2:4:8:VAL:HG12	2:4:118:LEU:HD23	1.90	0.53
2:4:87:ASP:OD2	2:6:36:LYS:NZ	2.41	0.53
1:a:154:MET:HG3	1:a:208:GLN:HB3	1.90	0.53

Continued on next page...

Continued from previous page...

Atom-1	Atom-2	Interatomic distance (Å)	Clash overlap (Å)
1:f:337:ALA:HB2	1:i:342:LEU:HD22	1.89	0.53
1:c:142:THR:HG21	1:c:262:PRO:HG2	1.91	0.53
1:c:167:ARG:HH21	1:c:196:GLN:HB3	1.73	0.53
1:d:270:ASP:OD1	1:d:273:ARG:NH1	2.41	0.53
2:3:54:SER:OG	2:3:63:LYS:O	2.24	0.53
2:5:51:THR:HG23	2:5:72:LEU:HD12	1.91	0.53
1:i:276:ASN:HD22	1:i:279:ASN:ND2	2.06	0.53
2:7:25:LEU:O	2:8:3:GLN:NE2	2.42	0.53
2:7:48:THR:O	2:7:104:ASN:ND2	2.36	0.53
2:4:26:VAL:HB	2:4:96:VAL:HB	1.90	0.53
1:b:151:THR:O	1:b:378:SER:HA	2.09	0.52
1:h:307:GLU:O	1:h:380:MET:HG2	2.09	0.52
1:h:254:TRP:CG	1:h:266:ILE:HD11	2.45	0.52
1:d:217:GLU:HA	1:d:220:GLU:HG2	1.90	0.52
1:a:52:PHE:HE2	1:a:320:LEU:HD22	1.74	0.52
1:b:314:ILE:HG22	1:b:373:VAL:HG22	1.91	0.52
1:i:130:ASN:OD1	1:i:133:ARG:NH2	2.33	0.52
2:1:37:VAL:HG22	2:1:114:VAL:HG22	1.91	0.52
1:b:254:TRP:CG	1:b:266:ILE:CD1	2.93	0.52
1:b:171:LYS:HD3	1:b:177:ALA:HB2	1.92	0.52
1:f:13:ILE:HG12	1:f:19:LEU:HD11	1.91	0.52
1:d:143:ASN:O	1:d:353:LYS:NZ	2.33	0.52
1:g:231:ASP:OD1	1:g:231:ASP:N	2.40	0.52
1:b:107:LYS:O	1:b:111:GLU:HG3	2.11	0.51
1:e:290:LYS:HG3	1:e:308:ILE:HG23	1.90	0.51
1:b:268:ASP:OD1	1:b:285:THR:OG1	2.23	0.51
2:7:10:TYR:CD2	2:7:118:LEU:HD21	2.46	0.51
1:d:9:ASN:HD22	1:d:11:ASN:HB2	1.75	0.51
1:e:135:LYS:HD3	1:e:254:TRP:CZ2	2.46	0.51
2:3:10:TYR:CD2	2:3:118:LEU:HD21	2.46	0.51
1:a:106:ILE:HG13	1:a:106:ILE:O	2.09	0.51
1:c:32:TRP:HZ2	1:d:179:PRO:HB2	1.75	0.51
1:c:52:PHE:HE2	1:c:320:LEU:HD22	1.76	0.51
1:c:151:THR:O	1:c:378:SER:HA	2.11	0.51
1:g:167:ARG:CD	1:g:198:THR:HG21	2.41	0.51
2:9:25:LEU:HD11	2:9:98:ALA:HB2	1.92	0.51
1:d:207:TYR:CE1	1:d:380:MET:SD	3.04	0.51
1:i:319:VAL:HG12	1:i:353:LYS:HA	1.92	0.51
1:f:12:ASN:OD1	1:f:14:SER:OG	2.19	0.51
1:g:167:ARG:HD2	1:g:198:THR:HG21	1.91	0.51
1:g:207:TYR:CB	1:g:380:MET:O	2.59	0.51

Continued on next page...

Continued from previous page...

Atom-1	Atom-2	Interatomic distance (Å)	Clash overlap (Å)
1:h:65:LYS:HD2	1:h:86:LEU:HD11	1.93	0.51
1:h:127:THR:O	1:h:131:GLU:HG2	2.11	0.51
2:2:10:TYR:CD2	2:2:118:LEU:HD21	2.46	0.51
1:d:52:PHE:HE2	1:d:320:LEU:HD22	1.76	0.50
1:f:254:TRP:HB3	1:f:266:ILE:HD11	1.94	0.50
1:h:319:VAL:HG12	1:h:353:LYS:HA	1.94	0.50
1:c:167:ARG:NH2	1:c:196:GLN:HE21	2.09	0.50
1:d:56:SER:O	1:d:58:GLN:N	2.40	0.50
1:h:136:ARG:HB3	1:h:351:VAL:HG11	1.94	0.50
1:c:16:ASN:HD21	1:c:18:ASN:HB2	1.76	0.50
1:c:183:ILE:HG13	1:c:201:ILE:HG13	1.92	0.50
1:c:357:GLN:NE2	1:c:368:ASN:OD1	2.37	0.50
1:f:207:TYR:CD2	1:f:380:MET:HE2	2.45	0.50
1:g:62:PRO:HD2	1:g:91:GLN:O	2.12	0.50
1:d:225:TYR:O	1:d:229:GLY:N	2.45	0.50
1:f:87:GLU:HG2	1:f:364:THR:HG21	1.92	0.50
1:g:23:VAL:HA	1:h:61:ARG:HB3	1.94	0.49
1:h:105:LYS:HZ1	1:h:113:GLU:CD	2.20	0.49
1:a:129:MET:HE2	1:a:345:VAL:HG13	1.94	0.49
1:b:264:SER:HB3	1:b:308:ILE:HG12	1.94	0.49
1:c:100:ASN:ND2	1:d:84:ASP:OD2	2.43	0.49
1:f:52:PHE:HE2	1:f:320:LEU:HD22	1.77	0.49
1:g:207:TYR:CD2	1:g:380:MET:HE2	2.48	0.49
1:h:116:ASP:O	1:h:120:GLU:HG2	2.12	0.49
1:a:254:TRP:CD1	1:a:266:ILE:CD1	2.94	0.49
1:c:255:ASN:OD1	1:c:258:ASN:N	2.39	0.49
1:i:265:SER:O	1:i:287:ARG:NH1	2.45	0.49
2:1:2:LYS:HA	2:1:124:VAL:O	2.12	0.49
2:6:36:LYS:HB3	2:6:115:LEU:HB3	1.94	0.49
1:e:104:SER:HB3	1:e:117:PHE:CD2	2.47	0.49
1:f:264:SER:HB3	1:f:308:ILE:HG12	1.94	0.49
1:b:212:LEU:HD23	1:b:240:LEU:HD22	1.93	0.49
1:b:12:ASN:ND2	1:c:277:LYS:HB2	2.27	0.49
1:c:167:ARG:NH2	1:c:196:GLN:HB3	2.28	0.49
1:d:251:ALA:HB3	1:d:261:MET:HG2	1.94	0.49
1:i:144:ASP:OD2	1:i:355:ARG:NH1	2.41	0.49
1:a:169:GLY:O	1:a:176:LYS:HD2	2.13	0.49
1:d:127:THR:O	1:d:131:GLU:HG2	2.13	0.49
1:c:289:PHE:CE2	1:c:377:VAL:HG21	2.45	0.49
1:d:307:GLU:O	1:d:380:MET:HB2	2.13	0.49
1:e:12:ASN:HB2	2:1:2:LYS:HE2	1.94	0.49

Continued on next page...

Continued from previous page...

Atom-1	Atom-2	Interatomic distance (Å)	Clash overlap (Å)
1:h:104:SER:O	1:h:340:LYS:HG2	2.12	0.49
1:e:155:ASN:OD1	1:e:155:ASN:N	2.46	0.48
2:5:10:TYR:CD2	2:5:118:LEU:HD21	2.48	0.48
1:e:151:THR:O	1:e:378:SER:HA	2.13	0.48
1:g:9:ASN:HD21	1:g:11:ASN:HB2	1.78	0.48
2:1:50:THR:HG22	2:1:102:ASN:HB3	1.93	0.48
1:a:127:THR:O	1:a:131:GLU:HG2	2.14	0.48
2:4:57:PHE:O	2:4:63:LYS:HG3	2.13	0.48
1:a:62:PRO:HD2	1:a:91:GLN:O	2.12	0.48
1:b:202:ILE:HB	1:b:248:VAL:HA	1.95	0.48
1:c:235:LEU:O	1:c:236:TYR:HB3	2.13	0.48
1:c:254:TRP:CG	1:c:266:ILE:HD11	2.49	0.48
1:f:207:TYR:CZ	1:f:380:MET:HE2	2.48	0.48
1:a:64:ILE:HG22	1:f:28:GLN:HB2	1.94	0.48
1:b:237:SER:HB3	1:c:197:ASN:OD1	2.14	0.48
1:i:332:ASP:OD2	1:i:334:THR:OG1	2.28	0.48
1:f:207:TYR:HE1	1:f:381:GLU:CD	2.21	0.48
1:g:13:ILE:HG12	1:g:19:LEU:HD11	1.95	0.48
2:3:71:ASN:OD1	2:3:79:LYS:NZ	2.38	0.48
1:a:137:ILE:HD11	1:a:321:LEU:HD11	1.96	0.48
2:3:106:ASN:O	2:3:107:ASN:ND2	2.47	0.48
2:5:69:LEU:HD21	2:5:82:THR:HG21	1.96	0.48
1:a:276:ASN:C	1:a:278:ALA:H	2.22	0.47
1:b:71:SER:O	1:b:82:ASN:ND2	2.47	0.47
2:3:8:VAL:HG12	2:3:118:LEU:HD23	1.96	0.47
1:a:128:TRP:O	1:a:132:GLU:HG2	2.15	0.47
1:a:251:ALA:HB3	1:a:261:MET:HG2	1.97	0.47
1:c:189:SER:OG	1:c:194:MET:SD	2.66	0.47
1:g:187:MET:HG3	1:g:194:MET:HE3	1.95	0.47
2:1:10:TYR:CD2	2:1:118:LEU:HD21	2.50	0.47
1:e:96:ASP:HB2	1:e:276:ASN:ND2	2.29	0.47
1:g:334:THR:HA	1:g:338:GLY:HA2	1.96	0.47
1:h:290:LYS:O	1:h:294:ASN:HB2	2.14	0.47
1:a:324:SER:HB3	1:a:326:GLU:HG3	1.96	0.47
1:b:223:LYS:HG3	1:c:224:LEU:HD21	1.95	0.47
1:f:218:PHE:CE2	1:f:222:ARG:HD2	2.49	0.47
1:g:360:ASP:OD1	1:g:361:GLY:N	2.46	0.47
1:h:41:THR:HG22	1:h:49:VAL:HB	1.96	0.47
2:4:64:ASN:HB2	2:4:68:THR:HG22	1.97	0.47
1:c:68:LEU:HD22	1:c:84:ASP:OD2	2.15	0.47
1:c:99:GLY:O	1:d:72:GLY:HA3	2.13	0.47

Continued on next page...

Continued from previous page...

Atom-1	Atom-2	Interatomic distance (Å)	Clash overlap (Å)
2:1:60:GLU:O	2:1:63:LYS:NZ	2.40	0.47
2:4:24:ASN:HA	2:4:97:VAL:HG12	1.96	0.47
1:d:141:LEU:HD11	1:d:314:ILE:HD11	1.97	0.47
1:f:151:THR:O	1:f:378:SER:HA	2.14	0.47
2:3:50:THR:H	2:3:104:ASN:HD21	1.61	0.47
2:6:18:PHE:HB2	2:6:108:VAL:O	2.15	0.47
1:a:134:ASP:C	1:a:259:VAL:HG21	2.40	0.47
1:a:190:VAL:O	1:a:190:VAL:HG12	2.15	0.47
1:g:127:THR:O	1:g:131:GLU:HG2	2.15	0.47
2:5:24:ASN:HA	2:5:97:VAL:HG12	1.95	0.47
1:h:105:LYS:NZ	1:h:113:GLU:CD	2.73	0.47
1:i:149:LEU:HD12	1:i:162:ALA:HB2	1.96	0.47
2:5:76:ASP:O	2:5:80:LYS:HG2	2.15	0.47
1:a:171:LYS:N	1:a:175:SER:O	2.47	0.47
2:8:10:TYR:CD2	2:8:118:LEU:HD21	2.49	0.47
1:f:43:THR:O	1:f:50:ARG:NH2	2.48	0.46
1:i:49:VAL:HG12	1:i:319:VAL:HG22	1.97	0.46
1:c:254:TRP:CG	1:c:266:ILE:CD1	2.98	0.46
2:5:76:ASP:OD1	2:5:76:ASP:N	2.48	0.46
1:h:223:LYS:HG2	1:h:227:PHE:CE2	2.50	0.46
1:i:217:GLU:OE1	1:i:217:GLU:N	2.47	0.46
2:6:10:TYR:CD2	2:6:118:LEU:HD21	2.51	0.46
1:d:339:ARG:NH2	1:h:77:THR:O	2.47	0.46
1:f:154:MET:HE3	1:f:159:ILE:HG12	1.98	0.46
1:g:104:SER:O	1:g:340:LYS:HD3	2.16	0.46
2:1:54:SER:OG	2:1:63:LYS:O	2.19	0.46
1:g:167:ARG:HH21	1:g:179:PRO:HB2	1.79	0.46
2:5:25:LEU:O	2:6:3:GLN:NE2	2.49	0.46
1:a:205:ASP:OD2	1:a:309:SER:OG	2.33	0.46
1:c:178:PHE:HZ	1:c:371:TYR:HA	1.80	0.46
1:e:73:VAL:HG22	1:e:77:THR:HB	1.98	0.46
1:f:108:ALA:HB1	1:i:348:LEU:HG	1.96	0.46
1:g:307:GLU:CB	1:g:380:MET:HG3	2.42	0.46
1:a:101:SER:HB2	1:a:342:LEU:HD11	1.96	0.46
1:e:96:ASP:HB2	1:e:276:ASN:HD21	1.80	0.46
2:4:58:GLU:HA	2:4:63:LYS:HE3	1.97	0.46
1:a:151:THR:O	1:a:378:SER:HA	2.16	0.46
1:b:73:VAL:HB	1:b:77:THR:HB	1.98	0.46
1:c:254:TRP:CB	1:c:266:ILE:HD11	2.45	0.46
1:d:69:SER:O	1:d:69:SER:OG	2.30	0.46
1:e:212:LEU:HD23	1:e:240:LEU:HD22	1.96	0.46

Continued on next page...

Continued from previous page...

Atom-1	Atom-2	Interatomic distance (Å)	Clash overlap (Å)
1:f:207:TYR:CE1	1:f:381:GLU:CD	2.94	0.46
1:g:42:GLY:HA3	1:g:47:ARG:HG3	1.96	0.46
1:i:137:ILE:HG23	1:i:319:VAL:HG21	1.97	0.46
1:e:104:SER:HB3	1:e:117:PHE:CE2	2.50	0.46
1:e:186:THR:O	1:e:196:GLN:HA	2.16	0.46
1:e:258:ASN:HD21	1:f:179:PRO:HG3	1.81	0.46
1:i:50:ARG:HG2	1:i:52:PHE:CZ	2.51	0.46
1:g:151:THR:O	1:g:378:SER:HA	2.16	0.45
1:b:128:TRP:O	1:b:132:GLU:HG2	2.16	0.45
1:d:128:TRP:CH2	1:d:132:GLU:HG3	2.51	0.45
1:e:263:ASN:OD1	1:e:265:SER:OG	2.30	0.45
2:4:5:VAL:O	2:4:121:VAL:HA	2.15	0.45
2:5:53:VAL:HG23	2:5:100:VAL:HB	1.99	0.45
2:6:16:PHE:O	2:6:109:LYS:HB2	2.17	0.45
2:9:70:ASP:O	2:9:79:LYS:CE	2.39	0.45
1:a:57:GLN:H	1:a:57:GLN:CD	2.23	0.45
1:d:6:ASN:HB3	2:4:13:LYS:O	2.17	0.45
1:g:132:GLU:O	1:g:136:ARG:HG2	2.16	0.45
1:i:32:TRP:O	1:i:34:LYS:HG3	2.16	0.45
2:4:3:GLN:NE2	2:6:25:LEU:O	2.48	0.45
1:a:51:LEU:HD22	1:a:325:LYS:HD3	1.98	0.45
1:a:267:SER:HA	1:a:287:ARG:HH11	1.81	0.45
1:h:131:GLU:O	1:h:135:LYS:HG3	2.16	0.45
2:1:26:VAL:HB	2:1:96:VAL:HB	1.98	0.45
1:a:321:LEU:HD22	1:a:351:VAL:HG22	1.98	0.45
1:d:154:MET:HG3	1:d:208:GLN:HB3	1.98	0.45
1:a:285:THR:H	1:a:288:GLN:HG3	1.82	0.45
1:b:104:SER:HB3	1:b:341:SER:N	2.29	0.45
1:d:357:GLN:HA	1:d:367:ASP:O	2.17	0.45
2:9:29:PRO:HG2	2:9:32:ALA:HB2	1.97	0.45
1:a:91:GLN:NE2	1:a:354:ALA:HA	2.32	0.45
1:c:127:THR:O	1:c:131:GLU:HG2	2.17	0.45
1:g:254:TRP:CD1	1:g:266:ILE:HD13	2.52	0.45
2:7:26:VAL:HB	2:7:96:VAL:HB	1.99	0.45
1:a:57:GLN:O	1:a:58:GLN:NE2	2.50	0.45
1:d:61:ARG:HE	1:d:92:THR:HB	1.81	0.45
1:i:270:ASP:N	1:i:270:ASP:OD2	2.45	0.45
2:6:87:ASP:OD1	2:6:87:ASP:N	2.42	0.45
2:7:126:TYR:CE2	2:9:29:PRO:HD3	2.50	0.45
1:c:367:ASP:OD1	1:c:367:ASP:N	2.50	0.45
1:d:184:ARG:HB2	1:d:199:SER:HB3	1.99	0.45

Continued on next page...

Continued from previous page...

Atom-1	Atom-2	Interatomic distance (Å)	Clash overlap (Å)
1:g:207:TYR:CG	1:g:380:MET:HE2	2.52	0.45
1:h:208:GLN:HE21	1:h:378:SER:HB3	1.82	0.45
1:h:234:MET:C	1:h:236:TYR:H	2.25	0.45
2:1:3:GLN:O	2:1:123:GLU:HA	2.17	0.45
2:6:67:LEU:HG	2:6:84:SER:HB3	1.99	0.45
1:b:309:SER:HB2	1:b:380:MET:HB3	1.98	0.44
1:d:337:ALA:O	1:g:330:TYR:HB3	2.17	0.44
2:9:2:LYS:HD3	2:9:123:GLU:OE2	2.17	0.44
1:a:284:VAL:HG23	1:a:288:GLN:HB2	1.98	0.44
1:c:251:ALA:HB3	1:c:261:MET:HG2	1.98	0.44
1:d:151:THR:O	1:d:378:SER:HA	2.17	0.44
1:d:106:ILE:N	1:h:76:ASN:OD1	2.45	0.44
1:d:261:MET:HB3	1:d:310:ILE:O	2.17	0.44
1:g:141:LEU:HD13	1:g:319:VAL:HG23	1.99	0.44
2:9:18:PHE:CZ	2:9:53:VAL:HG21	2.53	0.44
1:c:61:ARG:HA	1:c:91:GLN:O	2.17	0.44
1:d:33:ILE:HD12	1:d:258:ASN:HD21	1.82	0.44
1:d:321:LEU:HD22	1:d:351:VAL:HG22	1.99	0.44
1:e:205:ASP:OD2	1:e:207:TYR:HD1	2.00	0.44
2:9:40:GLU:HG3	2:9:81:HIS:NE2	2.31	0.44
1:a:99:GLY:O	1:b:72:GLY:HA3	2.18	0.44
1:e:128:TRP:O	1:e:132:GLU:HG2	2.17	0.44
1:f:220:GLU:O	1:f:224:LEU:HG	2.17	0.44
1:h:254:TRP:CG	1:h:266:ILE:CD1	3.01	0.44
1:a:61:ARG:HD2	1:f:23:VAL:HG22	2.00	0.44
1:d:220:GLU:O	1:d:224:LEU:HG	2.17	0.44
1:e:176:LYS:HD3	1:e:176:LYS:HA	1.66	0.44
1:g:113:GLU:O	1:h:63:ARG:NH1	2.46	0.44
1:h:254:TRP:HB3	1:h:266:ILE:HD11	1.99	0.44
2:2:29:PRO:HG2	2:2:32:ALA:HB2	2.00	0.44
2:4:18:PHE:CZ	2:4:53:VAL:HG21	2.53	0.44
2:4:18:PHE:HB2	2:4:108:VAL:O	2.18	0.44
2:6:2:LYS:HG2	2:6:125:GLU:HG3	2.00	0.44
1:d:207:TYR:O	1:d:381:GLU:OE1	2.36	0.44
1:h:61:ARG:HA	1:h:91:GLN:O	2.18	0.44
2:3:76:ASP:O	2:3:80:LYS:HG2	2.18	0.44
2:8:34:VAL:HB	2:8:88:TYR:HB3	2.00	0.44
1:b:206:SER:HB3	1:c:164:PHE:CD1	2.53	0.43
2:6:105:ASP:OD1	2:6:105:ASP:N	2.49	0.43
1:a:336:ASP:HB3	1:a:340:LYS:HG3	1.99	0.43
1:h:66:ALA:HB3	1:h:87:GLU:HB3	2.00	0.43

Continued on next page...

Continued from previous page...

Atom-1	Atom-2	Interatomic distance (Å)	Clash overlap (Å)
1:h:129:MET:HE3	1:h:345:VAL:HG22	2.00	0.43
1:c:237:SER:HB3	1:d:197:ASN:OD1	2.17	0.43
2:3:33:GLU:HB2	2:3:117:PHE:HB2	2.00	0.43
2:4:36:LYS:HB3	2:4:115:LEU:HB3	1.99	0.43
2:9:37:VAL:HG22	2:9:114:VAL:HG22	1.99	0.43
1:f:163:ILE:HD13	1:f:244:ASP:HB2	1.99	0.43
1:c:159:ILE:HG23	1:c:202:ILE:HD13	2.00	0.43
1:d:80:GLU:HA	1:d:83:TYR:CZ	2.54	0.43
1:i:263:ASN:HB2	1:i:308:ILE:O	2.18	0.43
1:d:277:LYS:HA	1:d:280:VAL:HG22	2.01	0.43
1:g:106:ILE:HD12	1:g:108:ALA:HB3	1.99	0.43
1:g:133:ARG:NH1	1:g:347:CYS:SG	2.92	0.43
1:h:222:ARG:HH22	1:h:231:ASP:HB3	1.83	0.43
1:h:225:TYR:O	1:h:229:GLY:N	2.35	0.43
1:c:41:THR:HA	1:c:49:VAL:O	2.19	0.43
1:i:34:LYS:NZ	1:i:258:ASN:HB3	2.34	0.43
1:c:273:ARG:NH1	1:c:274:TYR:OH	2.52	0.43
1:d:140:SER:O	1:d:353:LYS:HB2	2.18	0.43
1:d:23:VAL:HA	1:e:61:ARG:HB3	1.99	0.43
1:e:9:ASN:HB3	2:1:2:LYS:HG3	2.01	0.43
1:f:88:ILE:O	1:f:359:THR:HG23	2.18	0.43
2:6:9:SER:HB2	2:6:117:PHE:CE2	2.53	0.43
2:8:104:ASN:OD1	2:8:104:ASN:N	2.52	0.43
1:a:77:THR:OG1	2:1:125:GLU:O	2.36	0.43
1:c:167:ARG:HH21	1:c:196:GLN:HE21	1.65	0.43
1:f:17:LEU:O	1:i:61:ARG:HD3	2.19	0.43
1:g:52:PHE:CE2	1:g:320:LEU:HD22	2.48	0.43
1:h:88:ILE:O	1:h:359:THR:HG23	2.18	0.43
1:h:151:THR:O	1:h:378:SER:HA	2.18	0.43
1:i:271:PHE:HD2	1:i:285:THR:HG22	1.83	0.43
1:a:165:HIS:ND1	1:a:170:LEU:HB2	2.34	0.42
1:c:62:PRO:HD2	1:c:91:GLN:O	2.18	0.42
1:e:33:ILE:HG21	1:e:258:ASN:ND2	2.34	0.42
1:f:62:PRO:HD2	1:f:91:GLN:O	2.19	0.42
1:b:223:LYS:HG2	1:b:227:PHE:CE2	2.54	0.42
1:c:22:GLU:O	1:d:61:ARG:N	2.52	0.42
1:d:306:LYS:HD3	1:d:379:ASP:HB3	2.01	0.42
1:g:254:TRP:HB3	1:g:266:ILE:HD11	2.01	0.42
1:a:61:ARG:NH2	1:f:21:ILE:HD13	2.34	0.42
1:a:97:ALA:HA	1:a:347:CYS:O	2.19	0.42
1:d:290:LYS:O	1:d:294:ASN:HB2	2.19	0.42

Continued on next page...

Continued from previous page...

Atom-1	Atom-2	Interatomic distance (Å)	Clash overlap (Å)
1:g:146:THR:HG21	1:g:369:GLN:HA	2.01	0.42
1:a:58:GLN:HB3	1:f:20:GLY:O	2.20	0.42
1:a:91:GLN:HE21	1:a:320:LEU:HD12	1.84	0.42
1:a:264:SER:OG	1:a:307:GLU:OE1	2.33	0.42
1:c:135:LYS:HD3	1:c:254:TRP:CZ2	2.53	0.42
1:d:205:ASP:OD2	1:d:206:SER:N	2.52	0.42
1:e:55:ALA:O	1:e:56:SER:OG	2.31	0.42
1:a:73:VAL:HG11	1:a:78:ASP:O	2.19	0.42
1:c:142:THR:HG23	1:c:310:ILE:HG21	2.01	0.42
1:d:171:LYS:HB2	1:d:175:SER:HB2	2.01	0.42
2:2:18:PHE:HB2	2:2:108:VAL:O	2.20	0.42
1:a:69:SER:O	1:a:69:SER:OG	2.34	0.42
1:a:75:GLY:HA2	1:f:97:ALA:HB3	2.00	0.42
2:5:20:ASN:ND2	2:5:103:ALA:HB3	2.34	0.42
2:8:54:SER:OG	2:8:63:LYS:O	2.17	0.42
2:9:71:ASN:C	2:9:73:ALA:H	2.27	0.42
1:a:360:ASP:HB2	1:a:362:VAL:HG23	2.00	0.42
1:d:257:PHE:HB3	1:e:67:GLN:NE2	2.35	0.42
2:9:10:TYR:CD2	2:9:118:LEU:HD21	2.55	0.42
1:e:318:ALA:HB1	1:e:373:VAL:HG23	2.00	0.42
1:f:61:ARG:HA	1:f:91:GLN:O	2.19	0.42
1:g:9:ASN:ND2	1:g:11:ASN:HB2	2.35	0.42
1:g:135:LYS:HD3	1:g:254:TRP:CZ2	2.55	0.42
1:i:243:ILE:HD12	1:i:248:VAL:HG21	2.02	0.42
1:i:264:SER:OG	1:i:308:ILE:HG12	2.20	0.42
1:d:353:LYS:HE3	1:d:370:ASP:CG	2.45	0.42
1:h:276:ASN:C	1:h:278:ALA:H	2.28	0.42
2:1:1:MET:HE3	2:3:27:ALA:HB1	2.02	0.42
2:3:31:GLY:HA3	2:3:119:PRO:HB3	2.01	0.42
2:3:36:LYS:HB3	2:3:115:LEU:HB3	2.01	0.42
2:5:69:LEU:HD23	2:5:69:LEU:HA	1.83	0.42
2:7:64:ASN:HB2	2:7:68:THR:HG22	2.02	0.42
2:8:36:LYS:HB3	2:8:115:LEU:HB3	2.01	0.42
2:9:72:LEU:HD23	2:9:72:LEU:N	2.34	0.42
1:a:249:ILE:HD13	1:b:193:VAL:HG11	2.02	0.42
1:c:254:TRP:CD1	1:c:266:ILE:CD1	3.03	0.42
1:d:207:TYR:CD1	1:d:380:MET:SD	3.13	0.42
1:h:136:ARG:HA	1:h:136:ARG:HD3	1.83	0.42
2:6:22:VAL:HG22	2:6:99:GLU:HB3	2.02	0.42
1:a:52:PHE:CE2	1:a:320:LEU:HD22	2.54	0.41
1:a:268:ASP:HB3	1:a:272:MET:HE2	2.03	0.41

Continued on next page...

Continued from previous page...

Atom-1	Atom-2	Interatomic distance (Å)	Clash overlap (Å)
1:c:49:VAL:HG22	1:c:319:VAL:HG22	2.01	0.41
1:f:142:THR:HG22	1:f:142:THR:O	2.20	0.41
1:g:51:LEU:HA	1:g:321:LEU:HB2	2.02	0.41
1:h:143:ASN:O	1:h:353:LYS:NZ	2.44	0.41
2:5:9:SER:HB3	2:5:117:PHE:CE2	2.55	0.41
1:c:12:ASN:H	1:c:15:ASN:HD22	1.68	0.41
1:d:96:ASP:HB2	1:d:276:ASN:ND2	2.35	0.41
1:d:156:VAL:O	1:d:160:ARG:HG3	2.21	0.41
1:g:360:ASP:CG	1:g:361:GLY:H	2.28	0.41
1:c:104:SER:HB3	1:c:341:SER:H	1.84	0.41
1:e:146:THR:HG21	1:e:369:GLN:HA	2.01	0.41
1:f:78:ASP:N	1:f:78:ASP:OD1	2.38	0.41
2:1:55:VAL:HG21	2:1:112:LEU:HD13	2.02	0.41
2:2:31:GLY:HA3	2:2:119:PRO:HB3	2.02	0.41
1:b:99:GLY:HA3	1:b:345:VAL:O	2.21	0.41
1:e:33:ILE:HD11	1:f:167:ARG:NH1	2.35	0.41
1:f:107:LYS:HE3	1:f:107:LYS:HB2	1.74	0.41
1:b:183:ILE:HG13	1:b:201:ILE:HG13	2.03	0.41
1:d:194:MET:HE3	1:d:194:MET:HB3	1.98	0.41
2:2:57:PHE:O	2:2:60:GLU:HG2	2.19	0.41
2:5:46:ILE:HB	2:5:49:SER:HB3	2.03	0.41
2:6:88:TYR:CE2	2:6:90:ALA:HA	2.55	0.41
1:b:119:LYS:NZ	1:b:120:GLU:OE2	2.47	0.41
1:e:43:THR:O	1:e:50:ARG:NH2	2.54	0.41
1:f:207:TYR:CD2	1:f:380:MET:HE3	2.55	0.41
1:b:23:VAL:HG22	1:c:61:ARG:HD2	2.03	0.41
1:b:276:ASN:O	1:b:277:LYS:HB2	2.19	0.41
1:c:229:GLY:O	1:c:232:LYS:HE2	2.21	0.41
1:d:205:ASP:OD2	1:d:207:TYR:N	2.50	0.41
1:e:56:SER:O	1:e:58:GLN:HG2	2.20	0.41
1:h:180:ILE:HG22	1:h:200:TYR:HE1	1.85	0.41
1:i:56:SER:O	1:i:56:SER:OG	2.36	0.41
1:i:143:ASN:O	1:i:353:LYS:NZ	2.48	0.41
1:i:318:ALA:HA	1:i:372:ALA:HB3	2.02	0.41
1:a:91:GLN:HE22	1:a:354:ALA:HA	1.85	0.41
1:b:16:ASN:ND2	1:b:19:LEU:HG	2.36	0.41
1:c:8:ILE:HD11	2:7:26:VAL:C	2.46	0.41
1:c:204:LEU:HB3	1:c:208:GLN:HB2	2.03	0.41
1:c:217:GLU:OE2	1:c:217:GLU:N	2.54	0.41
1:d:134:ASP:HB3	1:d:259:VAL:HG11	2.02	0.41
1:d:206:SER:OG	1:d:250:ASP:OD1	2.32	0.41

Continued on next page...

Continued from previous page...

Atom-1	Atom-2	Interatomic distance (Å)	Clash overlap (Å)
1:e:360:ASP:CG	1:e:361:GLY:H	2.29	0.41
1:f:276:ASN:C	1:f:278:ALA:H	2.29	0.41
2:1:126:TYR:CE2	2:3:29:PRO:HD3	2.55	0.41
1:b:23:VAL:HA	1:c:61:ARG:HB3	2.02	0.41
1:b:128:TRP:CH2	1:b:132:GLU:HG3	2.56	0.41
1:i:221:LEU:HD23	1:i:221:LEU:HA	1.90	0.41
1:i:328:ARG:HD2	1:i:330:TYR:CZ	2.56	0.41
2:2:3:GLN:HG2	2:2:4:LYS:H	1.86	0.41
2:9:105:ASP:OD1	2:9:106:ASN:N	2.54	0.41
1:h:155:ASN:OD1	1:h:155:ASN:N	2.53	0.40
2:4:57:PHE:HB2	2:4:60:GLU:HG2	2.02	0.40
1:d:119:LYS:HE3	1:d:119:LYS:HB3	1.87	0.40
1:e:150:TYR:HD1	1:e:377:VAL:HG12	1.86	0.40
2:6:20:ASN:HA	2:6:100:VAL:HG13	2.03	0.40
1:e:159:ILE:O	1:e:163:ILE:HG13	2.21	0.40
1:e:221:LEU:HD21	1:e:225:TYR:CZ	2.56	0.40
2:5:101:LYS:HB3	2:5:101:LYS:HE2	1.75	0.40
1:a:275:LEU:HD13	1:a:283:ILE:HD12	2.03	0.40
1:b:231:ASP:N	1:b:231:ASP:OD1	2.54	0.40
1:c:137:ILE:HG23	1:c:319:VAL:HG21	2.03	0.40
1:g:225:TYR:O	1:g:229:GLY:N	2.40	0.40
2:7:67:LEU:HD22	2:7:82:THR:HG22	2.02	0.40
1:c:222:ARG:HH21	1:c:235:LEU:HA	1.85	0.40
1:d:268:ASP:HB3	1:d:272:MET:HE2	2.04	0.40
1:d:277:LYS:HG2	1:d:283:ILE:HD11	2.02	0.40
1:h:104:SER:HB2	1:h:117:PHE:CG	2.56	0.40
1:i:306:LYS:HE3	1:i:379:ASP:HB3	2.04	0.40
2:2:67:LEU:HG	2:2:84:SER:HB3	2.02	0.40
2:3:53:VAL:HG22	2:3:100:VAL:HG13	2.03	0.40
2:5:105:ASP:OD1	2:5:106:ASN:N	2.48	0.40

There are no symmetry-related clashes.

5.3 Torsion angles [\(i\)](#)

5.3.1 Protein backbone [\(i\)](#)

In the following table, the Percentiles column shows the percent Ramachandran outliers of the chain as a percentile score with respect to all PDB entries followed by that with respect to all EM entries.

The Analysed column shows the number of residues for which the backbone conformation was analysed, and the total number of residues.

Mol	Chain	Analysed	Favoured	Allowed	Outliers	Percentiles	
1	a	364/381 (96%)	338 (93%)	26 (7%)	0	100	100
1	b	362/381 (95%)	335 (92%)	27 (8%)	0	100	100
1	c	364/381 (96%)	340 (93%)	24 (7%)	0	100	100
1	d	367/381 (96%)	334 (91%)	33 (9%)	0	100	100
1	e	366/381 (96%)	343 (94%)	23 (6%)	0	100	100
1	f	366/381 (96%)	346 (94%)	20 (6%)	0	100	100
1	g	366/381 (96%)	336 (92%)	30 (8%)	0	100	100
1	h	358/381 (94%)	333 (93%)	25 (7%)	0	100	100
1	i	354/381 (93%)	332 (94%)	22 (6%)	0	100	100
2	1	124/126 (98%)	118 (95%)	6 (5%)	0	100	100
2	2	124/126 (98%)	121 (98%)	3 (2%)	0	100	100
2	3	124/126 (98%)	115 (93%)	9 (7%)	0	100	100
2	4	124/126 (98%)	117 (94%)	6 (5%)	1 (1%)	16	37
2	5	124/126 (98%)	116 (94%)	8 (6%)	0	100	100
2	6	124/126 (98%)	118 (95%)	6 (5%)	0	100	100
2	7	124/126 (98%)	121 (98%)	3 (2%)	0	100	100
2	8	124/126 (98%)	118 (95%)	6 (5%)	0	100	100
2	9	124/126 (98%)	115 (93%)	9 (7%)	0	100	100
All	All	4383/4563 (96%)	4096 (94%)	286 (6%)	1 (0%)	100	100

All (1) Ramachandran outliers are listed below:

Mol	Chain	Res	Type
2	4	77	ALA

5.3.2 Protein sidechains [i](#)

In the following table, the Percentiles column shows the percent sidechain outliers of the chain as a percentile score with respect to all PDB entries followed by that with respect to all EM entries.

The Analysed column shows the number of residues for which the sidechain conformation was analysed, and the total number of residues.

Mol	Chain	Analysed	Rotameric	Outliers	Percentiles	
1	a	317/330 (96%)	316 (100%)	1 (0%)	86	94
1	b	315/330 (96%)	313 (99%)	2 (1%)	78	91
1	c	317/330 (96%)	314 (99%)	3 (1%)	70	87
1	d	320/330 (97%)	313 (98%)	7 (2%)	45	74
1	e	319/330 (97%)	315 (99%)	4 (1%)	61	83
1	f	319/330 (97%)	317 (99%)	2 (1%)	78	91
1	g	319/330 (97%)	314 (98%)	5 (2%)	55	80
1	h	311/330 (94%)	310 (100%)	1 (0%)	86	94
1	i	315/330 (96%)	310 (98%)	5 (2%)	55	80
2	1	110/110 (100%)	108 (98%)	2 (2%)	51	78
2	2	110/110 (100%)	110 (100%)	0	100	100
2	3	110/110 (100%)	110 (100%)	0	100	100
2	4	110/110 (100%)	110 (100%)	0	100	100
2	5	110/110 (100%)	109 (99%)	1 (1%)	70	87
2	6	110/110 (100%)	110 (100%)	0	100	100
2	7	110/110 (100%)	110 (100%)	0	100	100
2	8	110/110 (100%)	110 (100%)	0	100	100
2	9	110/110 (100%)	108 (98%)	2 (2%)	51	78
All	All	3842/3960 (97%)	3807 (99%)	35 (1%)	68	87

All (35) residues with a non-rotameric sidechain are listed below:

Mol	Chain	Res	Type
1	a	155	ASN
1	b	107	LYS
1	b	266	ILE
1	c	107	LYS
1	c	164	PHE
1	c	197	ASN
1	d	88	ILE
1	d	105	LYS
1	d	197	ASN
1	d	263	ASN
1	d	267	SER
1	d	380	MET
1	d	381	GLU
1	e	88	ILE

Continued on next page...

Continued from previous page...

Mol	Chain	Res	Type
1	e	106	ILE
1	e	173	ASP
1	e	381	GLU
1	f	103	ARG
1	f	183	ILE
1	g	107	LYS
1	g	244	ASP
1	g	366	TYR
1	g	380	MET
1	g	381	GLU
1	h	183	ILE
1	i	12	ASN
1	i	13	ILE
1	i	14	SER
1	i	21	ILE
1	i	265	SER
2	1	1	MET
2	1	100	VAL
2	5	100	VAL
2	9	78	SER
2	9	80	LYS

Sometimes sidechains can be flipped to improve hydrogen bonding and reduce clashes. All (67) such sidechains are listed below:

Mol	Chain	Res	Type
1	a	7	ASN
1	a	15	ASN
1	a	91	GLN
1	a	174	ASN
1	a	188	GLN
1	a	196	GLN
1	b	12	ASN
1	b	16	ASN
1	b	29	ASN
1	b	57	GLN
1	b	288	GLN
1	b	295	GLN
1	c	15	ASN
1	c	16	ASN
1	c	168	ASN
1	c	174	ASN
1	c	196	GLN

Continued on next page...

Continued from previous page...

Mol	Chain	Res	Type
1	c	208	GLN
1	c	211	GLN
1	c	305	ASN
1	d	9	ASN
1	d	58	GLN
1	d	174	ASN
1	d	210	ASN
1	d	263	ASN
1	d	276	ASN
1	e	6	ASN
1	e	7	ASN
1	e	58	GLN
1	e	174	ASN
1	e	192	ASN
1	e	276	ASN
1	e	295	GLN
1	f	11	ASN
1	f	58	GLN
1	f	188	GLN
1	f	208	GLN
1	f	263	ASN
1	f	294	ASN
1	f	369	GLN
1	g	11	ASN
1	g	16	ASN
1	g	18	ASN
1	g	85	ASN
1	g	168	ASN
1	h	165	HIS
1	h	258	ASN
1	h	276	ASN
1	h	369	GLN
1	i	16	ASN
1	i	147	ASN
1	i	152	GLN
1	i	168	ASN
1	i	276	ASN
2	1	6	HIS
2	2	3	GLN
2	2	24	ASN
2	2	106	ASN
2	4	102	ASN

Continued on next page...

Continued from previous page...

Mol	Chain	Res	Type
2	5	6	HIS
2	6	3	GLN
2	6	102	ASN
2	7	81	HIS
2	8	19	ASN
2	8	93	ASN
2	9	106	ASN
2	9	107	ASN

5.3.3 RNA [i](#)

There are no RNA molecules in this entry.

5.4 Non-standard residues in protein, DNA, RNA chains [i](#)

There are no non-standard protein/DNA/RNA residues in this entry.

5.5 Carbohydrates [i](#)

There are no oligosaccharides in this entry.

5.6 Ligand geometry [i](#)

There are no ligands in this entry.

5.7 Other polymers [i](#)

There are no such residues in this entry.

5.8 Polymer linkage issues [i](#)

There are no chain breaks in this entry.

6 Map visualisation [i](#)

This section contains visualisations of the EMDB entry EMD-30778. These allow visual inspection of the internal detail of the map and identification of artifacts.

No raw map or half-maps were deposited for this entry and therefore no images, graphs, etc. pertaining to the raw map can be shown.

6.1 Orthogonal projections [i](#)

6.1.1 Primary map

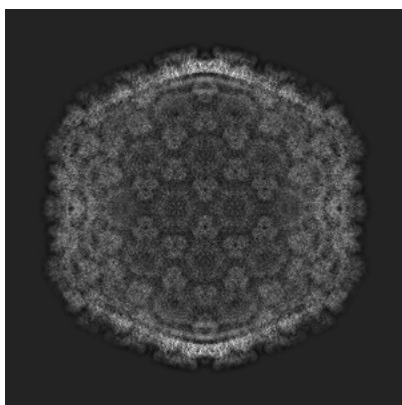

X

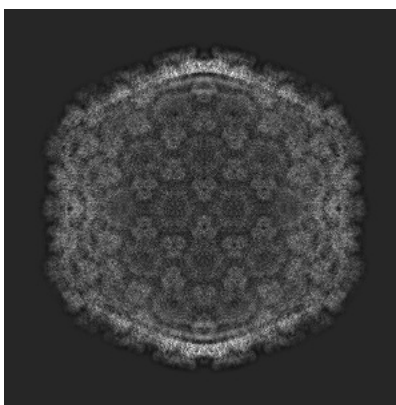

Y

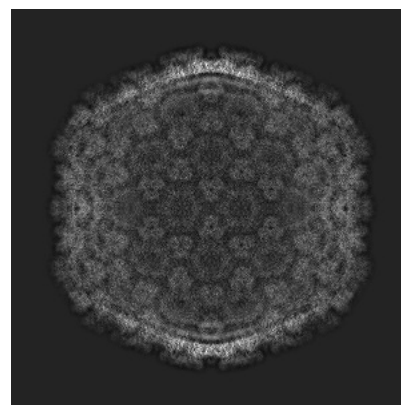

Z

The images above show the map projected in three orthogonal directions.

6.2 Central slices [i](#)

6.2.1 Primary map

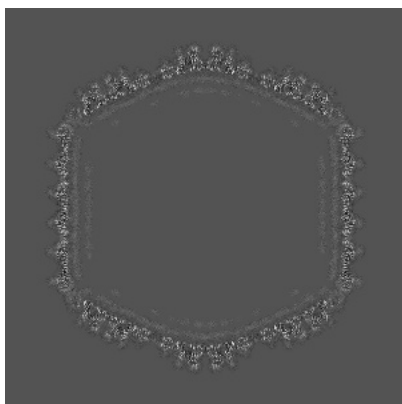

X Index: 375



Y Index: 375

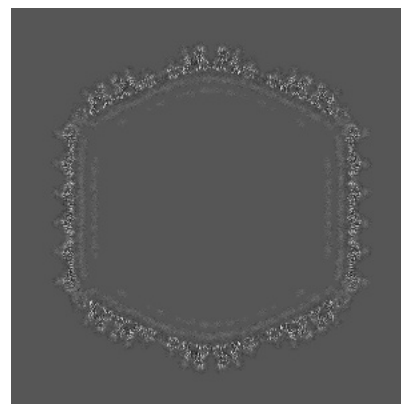

Z Index: 375

The images above show central slices of the map in three orthogonal directions.

6.3 Largest variance slices [i](#)

6.3.1 Primary map



X Index: 446

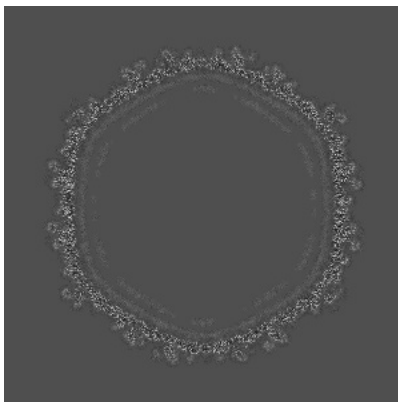

Y Index: 446



Z Index: 304

The images above show the largest variance slices of the map in three orthogonal directions.

6.4 Orthogonal standard-deviation projections (False-color) [i](#)

6.4.1 Primary map

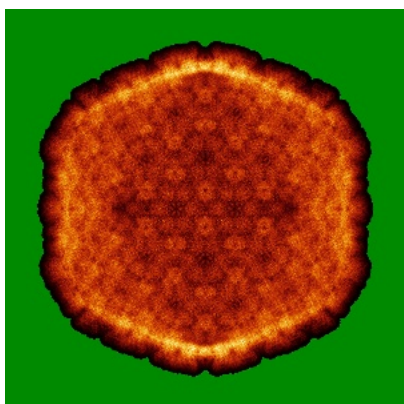

X

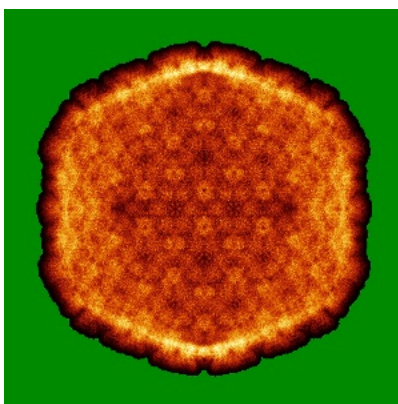

Y

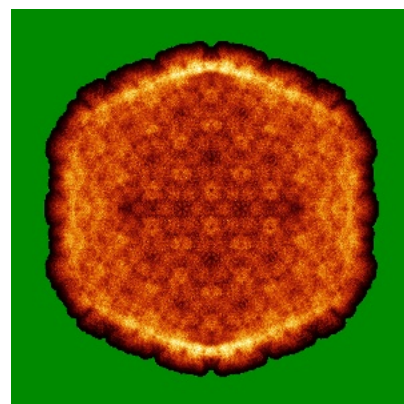

Z

The images above show the map standard deviation projections with false color in three orthogonal directions. Minimum values are shown in green, max in blue, and dark to light orange shades represent small to large values respectively.

6.5 Orthogonal surface views

This section was not generated.

6.6 Mask visualisation

This section was not generated. No masks/segmentation were deposited.

7 Map analysis [i](#)

This section contains the results of statistical analysis of the map.

7.1 Map-value distribution [i](#)

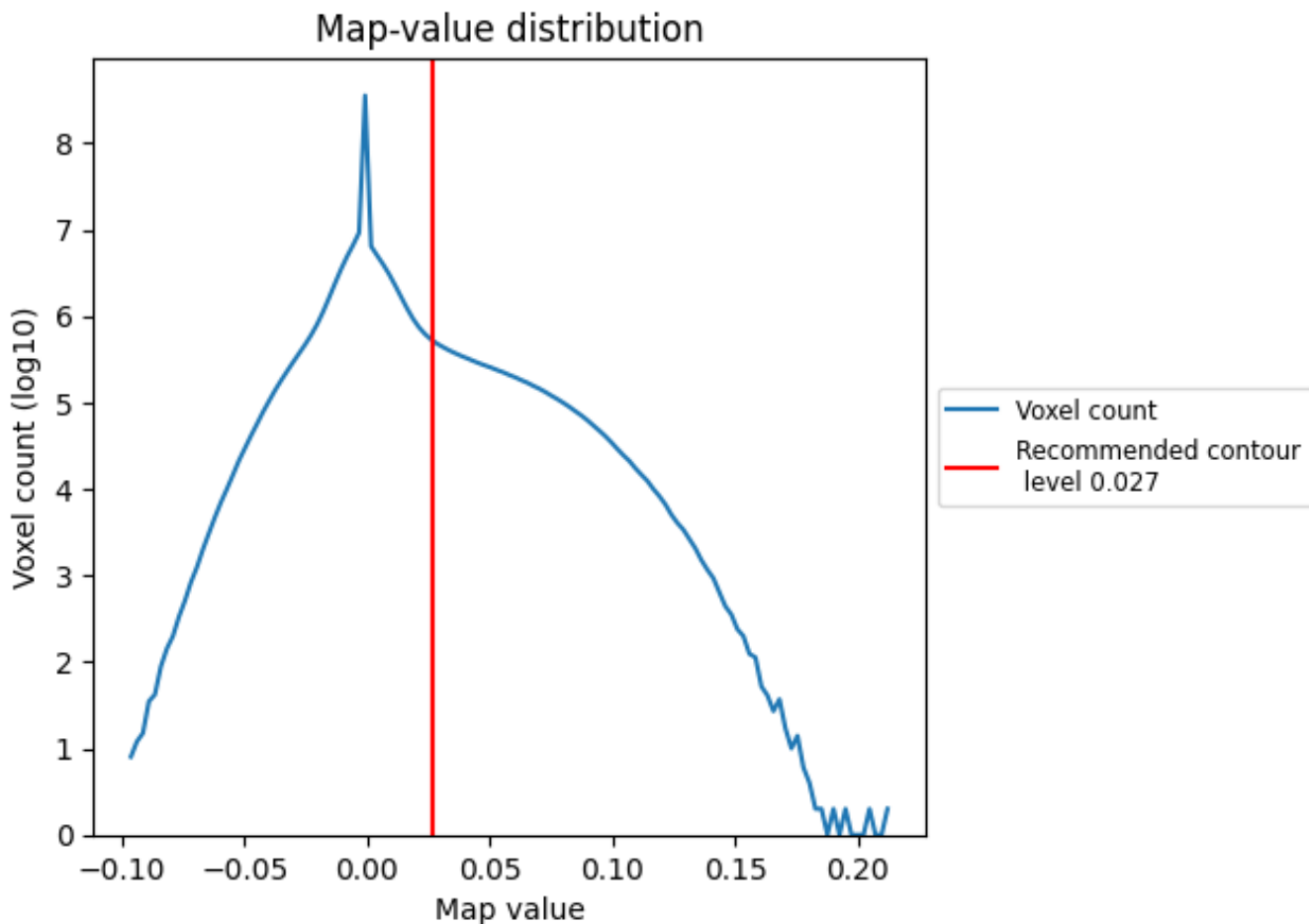

The map-value distribution is plotted in 128 intervals along the x-axis. The y-axis is logarithmic. A spike in this graph at zero usually indicates that the volume has been masked.

7.2 Volume estimate [\(i\)](#)

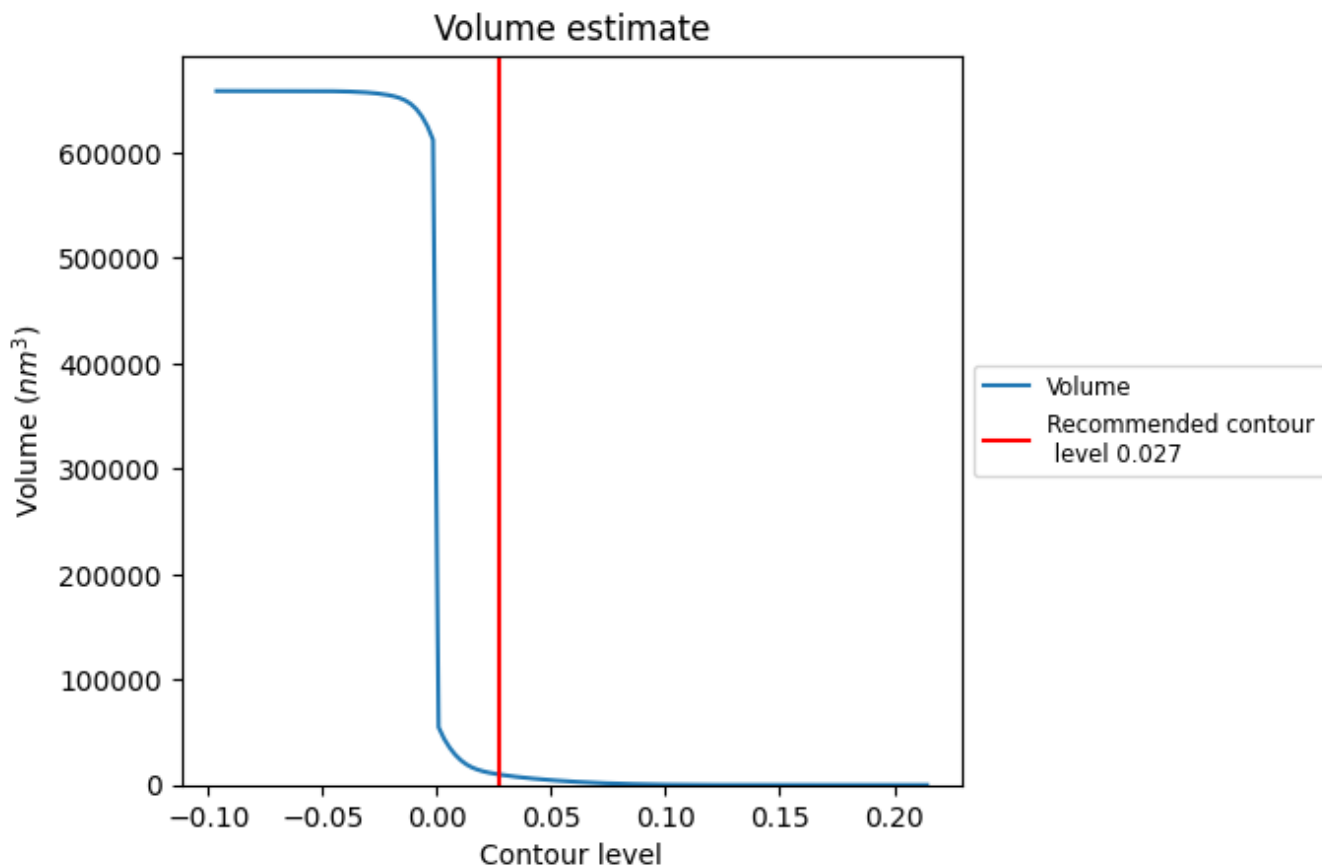

The volume at the recommended contour level is 10032 nm^3 ; this corresponds to an approximate mass of 9062 kDa.

The volume estimate graph shows how the enclosed volume varies with the contour level. The recommended contour level is shown as a vertical line and the intersection between the line and the curve gives the volume of the enclosed surface at the given level.

7.3 Rotationally averaged power spectrum [i](#)

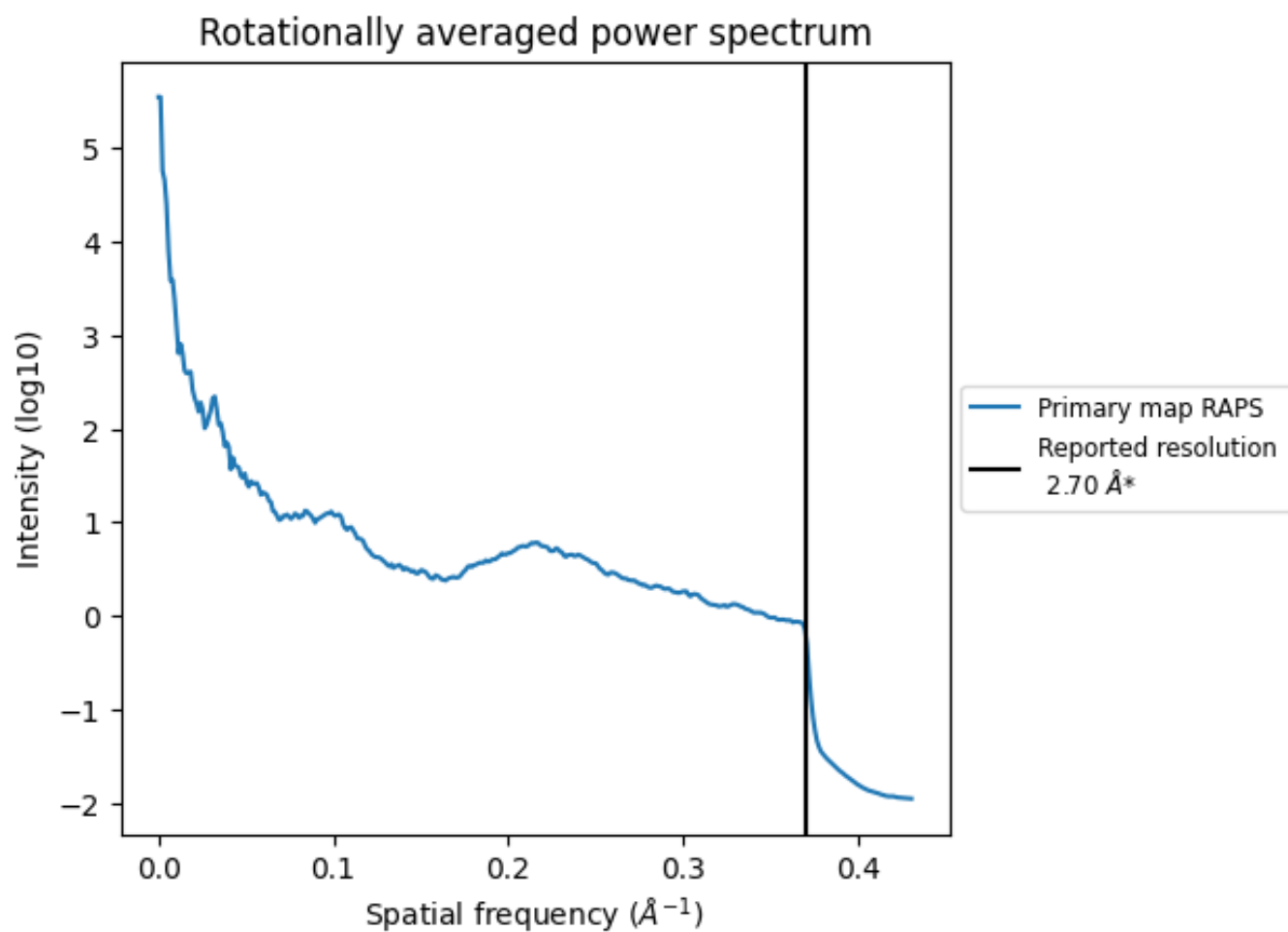

*Reported resolution corresponds to spatial frequency of 0.370 \AA^{-1}

8 Fourier-Shell correlation [i](#)

Fourier-Shell Correlation (FSC) is the most commonly used method to estimate the resolution of single-particle and subtomogram-averaged maps. The shape of the curve depends on the imposed symmetry, mask and whether or not the two 3D reconstructions used were processed from a common reference. The reported resolution is shown as a black line. A curve is displayed for the half-bit criterion in addition to lines showing the 0.143 gold standard cut-off and 0.5 cut-off.

8.1 FSC [i](#)

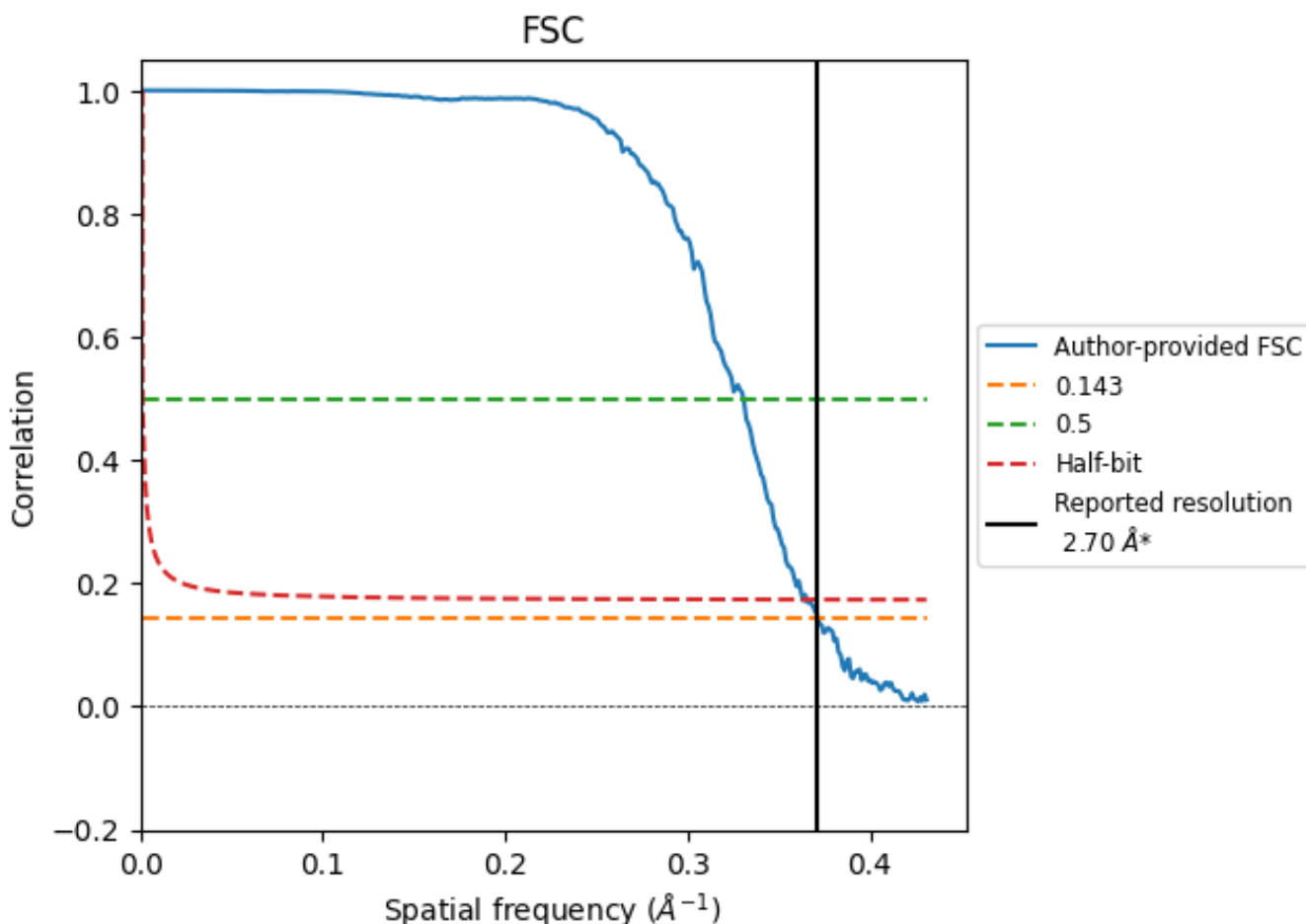

*Reported resolution corresponds to spatial frequency of 0.370 Å⁻¹

8.2 Resolution estimates [i](#)

Resolution estimate (Å)	Estimation criterion (FSC cut-off)		
	0.143	0.5	Half-bit
Reported by author	2.70	-	-
Author-provided FSC curve	2.69	3.02	2.75
Unmasked-calculated*	-	-	-

*Resolution estimate based on FSC curve calculated by comparison of deposited half-maps.

9 Map-model fit [i](#)

This section contains information regarding the fit between EMDB map EMD-30778 and PDB model 7DN2. Per-residue inclusion information can be found in section 3 on page 6.

9.1 Map-model overlay [i](#)

This section was not generated.

9.2 Q-score mapped to coordinate model [i](#)

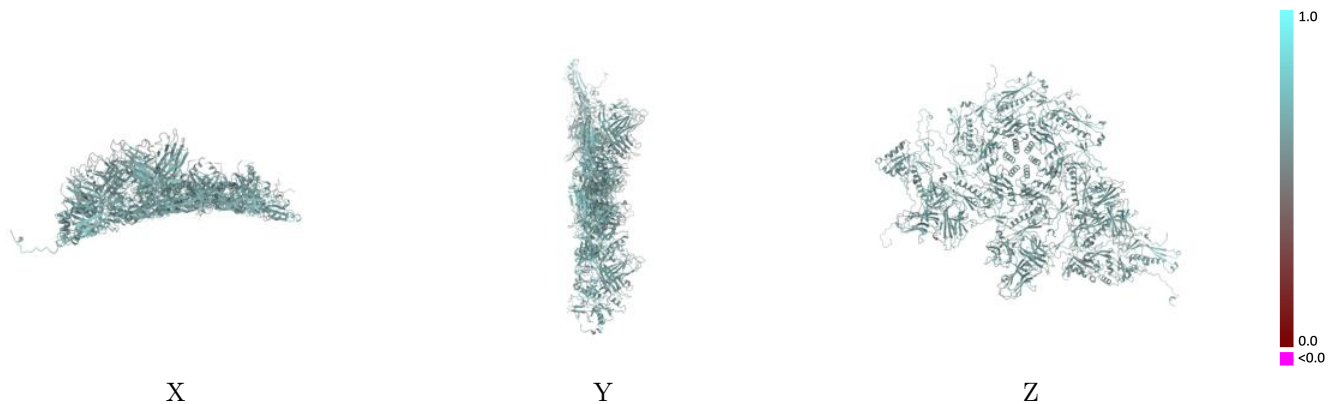

The images above show the model with each residue coloured according to its Q-score. This shows their resolvability in the map with higher Q-score values reflecting better resolvability. Please note: Q-score is calculating the resolvability of atoms, and thus high values are only expected at resolutions at which atoms can be resolved. Low Q-score values may therefore be expected for many entries.

9.3 Atom inclusion mapped to coordinate model [i](#)

This section was not generated.



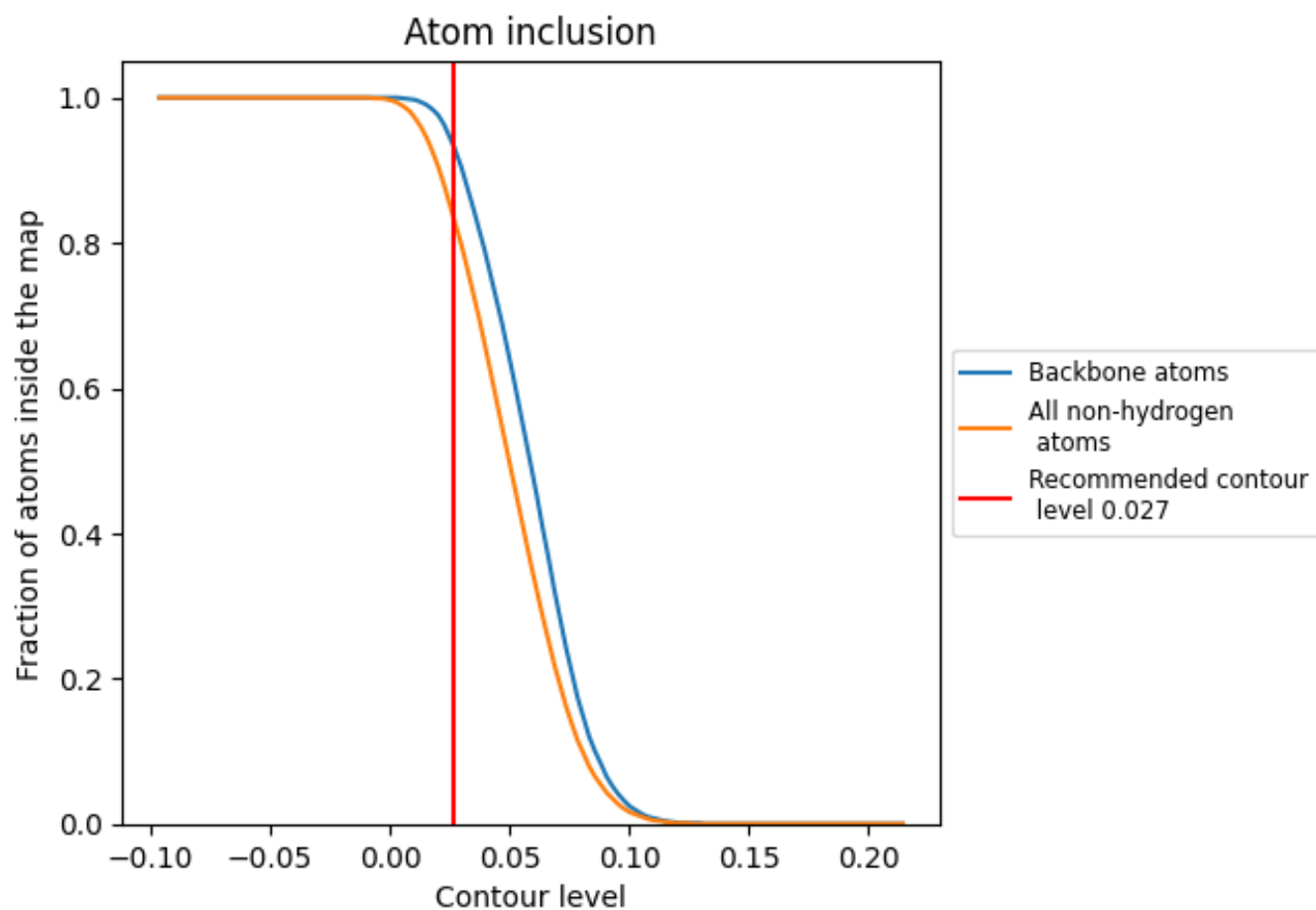



































9.4 Atom inclusion [i](#)



At the recommended contour level, 93% of all backbone atoms, 83% of all non-hydrogen atoms, are inside the map.

9.5 Map-model fit summary

The table lists the average atom inclusion at the recommended contour level (0.027) and Q-score for the entire model and for each chain.

Chain	Atom inclusion	Q-score
All	 0.8310	 0.6110
1	 0.7880	 0.6110
2	 0.8250	 0.6170
3	 0.7830	 0.6070
4	 0.8030	 0.6070
5	 0.8050	 0.6030
6	 0.7950	 0.6010
7	 0.8180	 0.6090
8	 0.8020	 0.5970
9	 0.7880	 0.5960
a	 0.8610	 0.6220
b	 0.8540	 0.6170
c	 0.8680	 0.6190
d	 0.8540	 0.6160
e	 0.8480	 0.6100
f	 0.8610	 0.6240
g	 0.8350	 0.6030
h	 0.8360	 0.6090
i	 0.7580	 0.5990

