



wwPDB EM Validation Summary Report ⓘ

Mar 24, 2026 – 11:17 AM UTC

PDB ID : 8ENV / pdb_00008env
EMDB ID : EMD-28280
Title : In situ cryo-EM structure of Pseudomonas phage E217 tail baseplate in C6 map
Authors : Li, F.; Cingolani, G.; Hou, C.
Deposited on : 2022-09-30
Resolution : 3.42 Å(reported)

This is a wwPDB EM Validation Summary Report for a publicly released PDB entry.

We welcome your comments at validation@mail.wwpdb.org

A user guide is available at

<https://www.wwpdb.org/validation/2017/EMValidationReportHelp>

with specific help available everywhere you see the ⓘ symbol.

The types of validation reports are described at

<http://www.wwpdb.org/validation/2017/FAQs#types>.

The following versions of software and data (see [references ⓘ](#)) were used in the production of this report:

EMDB validation analysis : 0.0.1.dev132
MolProbity : 4-5-2 with Phenix2.0
Percentile statistics : 20250101.v01 (using entries in the PDB archive January 1st 2025)
EM percentile statistics : 202505.v01 (Using data in the EMDB archive up until May 2025)
MapQ : 1.9.13
Ideal geometry (proteins) : Engh & Huber (2001)
Ideal geometry (DNA, RNA) : Parkinson et al. (1996)
Validation Pipeline (wwPDB-VP) : 2.49

1 Overall quality at a glance i

The following experimental techniques were used to determine the structure:
ELECTRON MICROSCOPY

The reported resolution of this entry is 3.42 Å.

Percentile scores (ranging between 0-100) for global validation metrics of the entry are shown in the following graphic. The table shows the number of entries on which the scores are based.

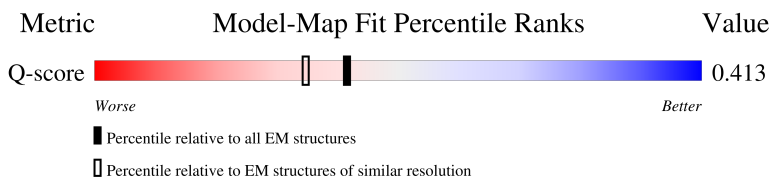
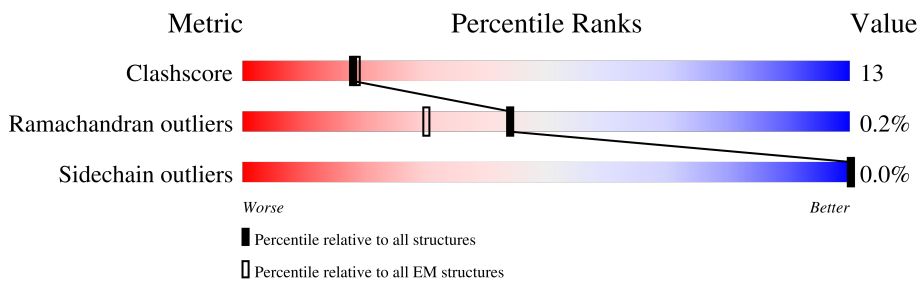

Metric	Whole archive (#Entries)	EM structures (#Entries)	Similar EM resolution (#Entries, resolution range(Å))
Clashscore	229148	23984	-
Ramachandran outliers	224038	23583	-
Sidechain outliers	223484	23102	-
Q-score	-	25397	13959 (2.92 - 3.92)

The table below summarises the geometric issues observed across the polymeric chains and their fit to the map. The red, orange, yellow and green segments of the bar indicate the fraction of residues that contain outliers for ≥ 3 , 2, 1 and 0 types of geometric quality criteria respectively. A grey segment represents the fraction of residues that are not modelled. The numeric value for each fraction is indicated below the corresponding segment, with a dot representing fractions $\leq 5\%$. The upper red bar (where present) indicates the fraction of residues that have poor fit to the EM map (all-atom inclusion $< 40\%$). The numeric value is given above the bar.

Mol	Chain	Length	Quality of chain
1	A	504	78% (green), 21% (yellow)
1	B	504	77% (green), 23% (yellow)
1	C	504	77% (green), 23% (yellow)
1	D	504	78% (green), 22% (yellow)

Continued on next page...

Continued from previous page...

Mol	Chain	Length	Quality of chain
1	E	504	74% 26%
1	F	504	77% 23%
2	G	102	81% 18%
2	L	102	80% 19%
2	Q	102	79% 20%
2	V	102	86% 13%
2	a	102	74% 25%
2	f	102	86% 13%
3	H	108	77% 23%
3	M	108	77% 23%
3	R	108	80% 20%
3	W	108	80% 20%
3	b	108	77% 23%
3	g	108	72% 28%
4	I	152	80% 20%
4	N	152	86% 14%
4	S	152	85% 15%
4	X	152	89% 11%
4	c	152	82% 18%
4	h	152	80% 19%
5	J	417	6% 70% 30%
5	O	417	7% 74% 26%
5	T	417	7% 74% 26%
5	Y	417	7% 70% 30%
5	d	417	7% 72% 28%

Continued on next page...

Continued from previous page...

Mol	Chain	Length	Quality of chain
5	i	417	6% 70% 30%
6	K	500	15% 64% 36%
6	P	500	15% 62% 38%
6	U	500	18% 69% 31%
6	Z	500	17% 66% 34%
6	e	500	17% 68% 32%
6	j	500	16% 67% 32%

2 Entry composition [i](#)

There are 6 unique types of molecules in this entry. The entry contains 80436 atoms, of which 0 are hydrogens and 0 are deuteriums.

In the tables below, the AltConf column contains the number of residues with at least one atom in alternate conformation and the Trace column contains the number of residues modelled with at most 2 atoms.

- Molecule 1 is a protein called Sheath protein gp31.

Mol	Chain	Residues	Atoms					AltConf	Trace
			Total	C	N	O	S		
1	A	504	3780	2380	639	749	12	0	0
1	B	504	3780	2380	639	749	12	0	0
1	C	504	3780	2380	639	749	12	0	0
1	D	504	3780	2380	639	749	12	0	0
1	E	504	3780	2380	639	749	12	0	0
1	F	504	3780	2380	639	749	12	0	0

There are 6 discrepancies between the modelled and reference sequences:

Chain	Residue	Modelled	Actual	Comment	Reference
A	17	ALA	GLY	conflict	UNP A0A2K8IA62
B	17	ALA	GLY	conflict	UNP A0A2K8IA62
C	17	ALA	GLY	conflict	UNP A0A2K8IA62
D	17	ALA	GLY	conflict	UNP A0A2K8IA62
E	17	ALA	GLY	conflict	UNP A0A2K8IA62
F	17	ALA	GLY	conflict	UNP A0A2K8IA62

- Molecule 2 is a protein called Structural protein gp33.

Mol	Chain	Residues	Atoms					AltConf	Trace
			Total	C	N	O	S		
2	G	102	816	525	136	150	5	0	0
2	L	102	816	525	136	150	5	0	0
2	Q	102	816	525	136	150	5	0	0
2	V	102	816	525	136	150	5	0	0

Continued on next page...

Continued from previous page...

Mol	Chain	Residues	Atoms					AltConf	Trace
2	a	102	Total	C	N	O	S	0	0
			816	525	136	150	5		
2	f	102	Total	C	N	O	S	0	0
			816	525	136	150	5		

- Molecule 3 is a protein called Sheath initiator gp34.

Mol	Chain	Residues	Atoms					AltConf	Trace
3	H	108	Total	C	N	O	S	0	0
			823	510	137	172	4		
3	M	108	Total	C	N	O	S	0	0
			823	510	137	172	4		
3	R	108	Total	C	N	O	S	0	0
			823	510	137	172	4		
3	W	108	Total	C	N	O	S	0	0
			823	510	137	172	4		
3	b	108	Total	C	N	O	S	0	0
			823	510	137	172	4		
3	g	108	Total	C	N	O	S	0	0
			823	510	137	172	4		

- Molecule 4 is a protein called Ripcord gp36.

Mol	Chain	Residues	Atoms					AltConf	Trace
4	I	152	Total	C	N	O	S	0	0
			1133	726	182	221	4		
4	N	152	Total	C	N	O	S	0	0
			1133	726	182	221	4		
4	S	152	Total	C	N	O	S	0	0
			1133	726	182	221	4		
4	X	152	Total	C	N	O	S	0	0
			1133	726	182	221	4		
4	c	152	Total	C	N	O	S	0	0
			1133	726	182	221	4		
4	h	152	Total	C	N	O	S	0	0
			1133	726	182	221	4		

- Molecule 5 is a protein called Baseplate_J domain-containing protein gp44.

Mol	Chain	Residues	Atoms					AltConf	Trace
5	J	417	Total	C	N	O	S	0	0
			3036	1901	526	597	12		

Continued on next page...

Continued from previous page...

Mol	Chain	Residues	Atoms					AltConf	Trace
5	O	417	Total	C	N	O	S	0	0
			3036	1901	526	597	12		
5	T	417	Total	C	N	O	S	0	0
			3036	1901	526	597	12		
5	Y	417	Total	C	N	O	S	0	0
			3036	1901	526	597	12		
5	d	417	Total	C	N	O	S	0	0
			3036	1901	526	597	12		
5	i	417	Total	C	N	O	S	0	0
			3036	1901	526	597	12		

- Molecule 6 is a protein called Structural protein gp45.

Mol	Chain	Residues	Atoms					AltConf	Trace
6	K	500	Total	C	N	O	S	0	0
			3818	2435	641	729	13		
6	P	500	Total	C	N	O	S	0	0
			3818	2435	641	729	13		
6	U	500	Total	C	N	O	S	0	0
			3818	2435	641	729	13		
6	Z	500	Total	C	N	O	S	0	0
			3818	2435	641	729	13		
6	e	500	Total	C	N	O	S	0	0
			3818	2435	641	729	13		
6	j	500	Total	C	N	O	S	0	0
			3818	2435	641	729	13		

Chain C:

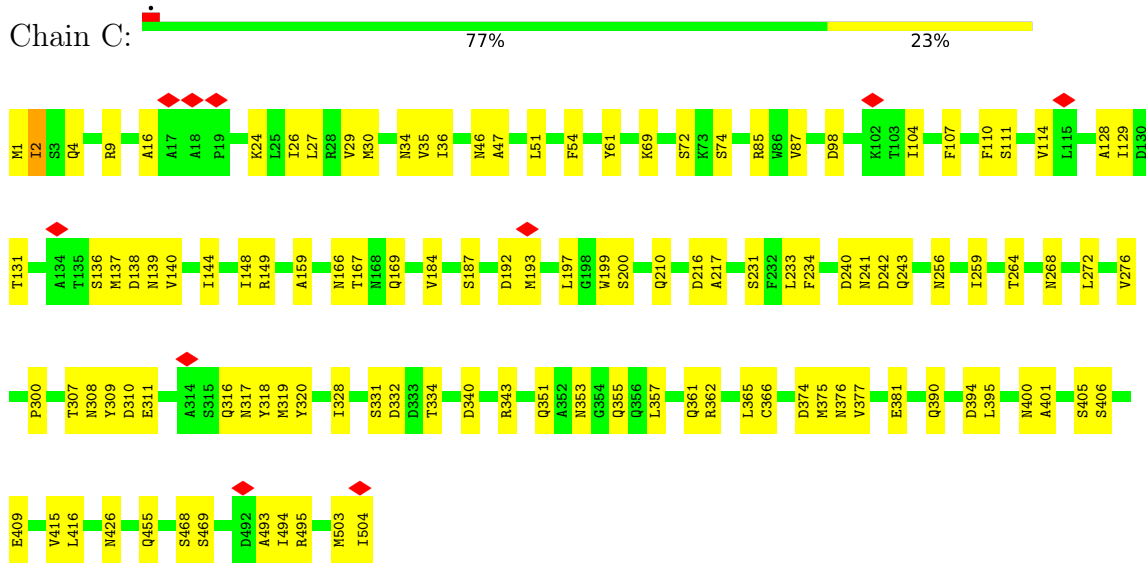

- Molecule 1: Sheath protein gp31

Chain D:

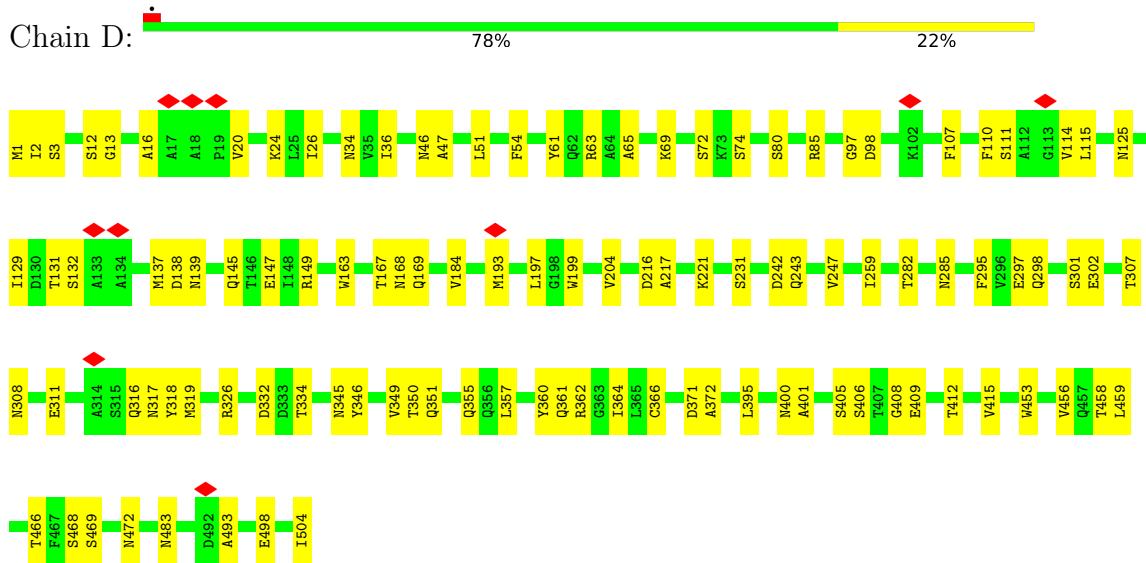

- Molecule 1: Sheath protein gp31

Chain E:

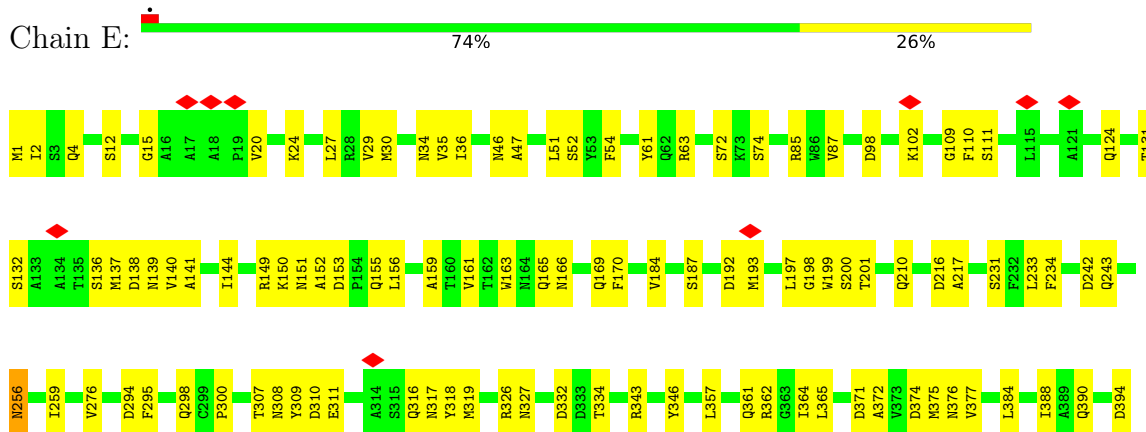



• Molecule 1: Sheath protein gp31

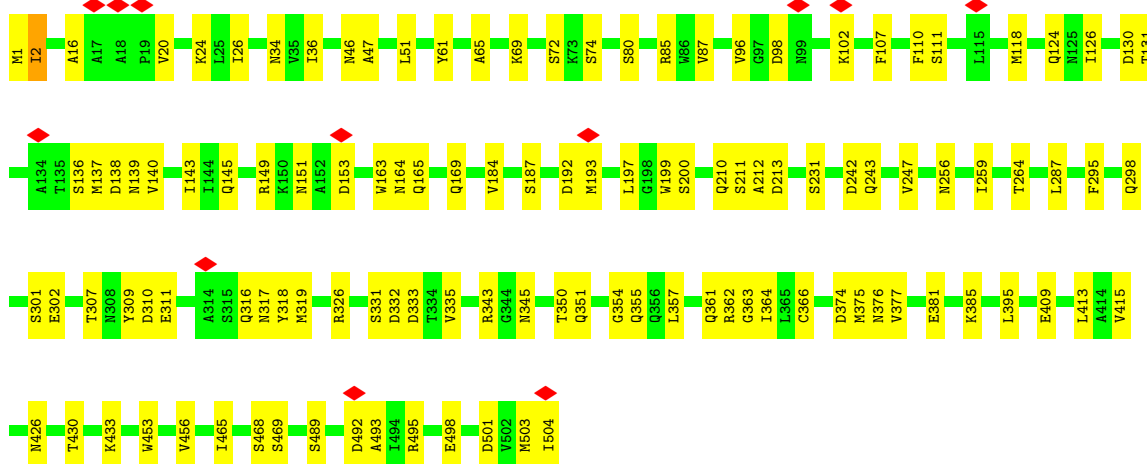
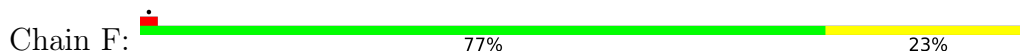

• Molecule 2: Structural protein gp33

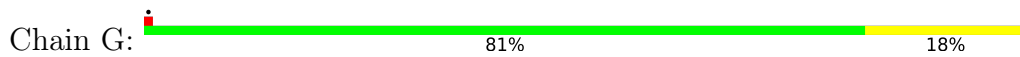

• Molecule 2: Structural protein gp33

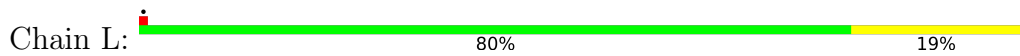

• Molecule 2: Structural protein gp33

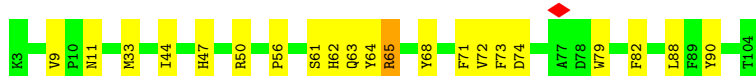
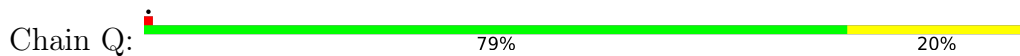

• Molecule 2: Structural protein gp33

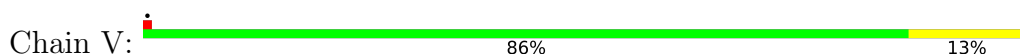

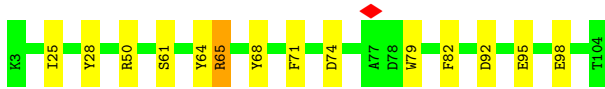

- Molecule 2: Structural protein gp33

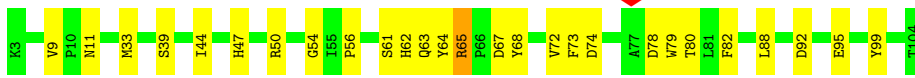
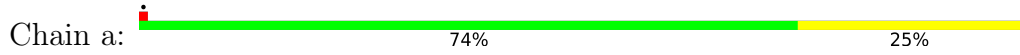

- Molecule 2: Structural protein gp33

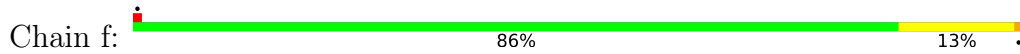

- Molecule 3: Sheath initiator gp34

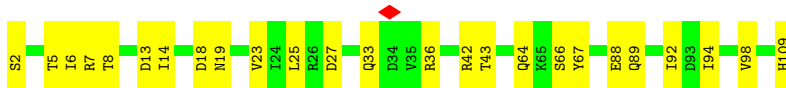
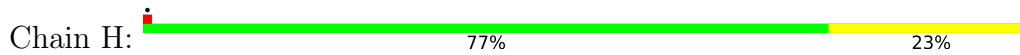

- Molecule 3: Sheath initiator gp34

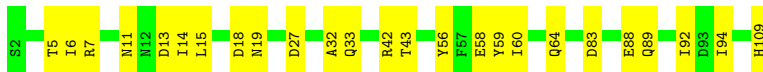
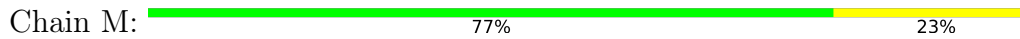

- Molecule 3: Sheath initiator gp34

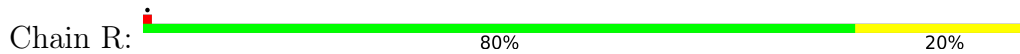

- Molecule 3: Sheath initiator gp34

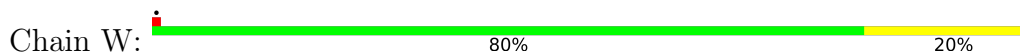

- Molecule 3: Sheath initiator gp34

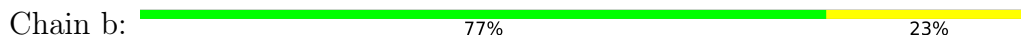

• Molecule 3: Sheath initiator gp34



• Molecule 4: Ripcord gp36

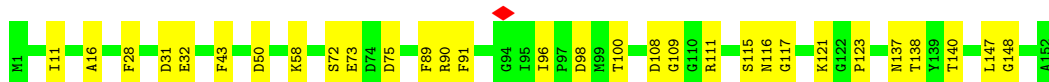
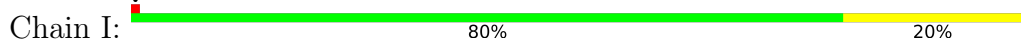

• Molecule 4: Ripcord gp36

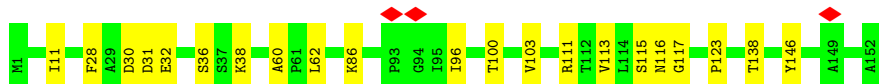

• Molecule 4: Ripcord gp36

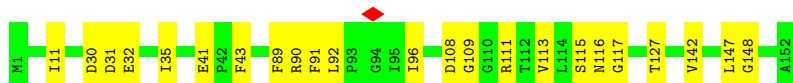
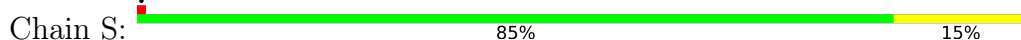

• Molecule 4: Ripcord gp36

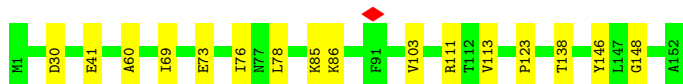

• Molecule 4: Ripcord gp36

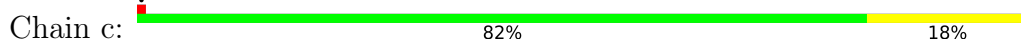

• Molecule 4: Ripcord gp36

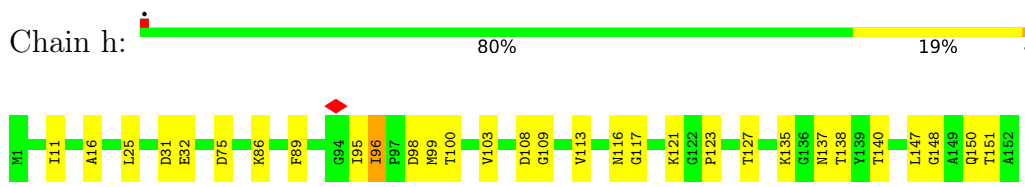

• Molecule 5: Baseplate_J domain-containing protein gp44

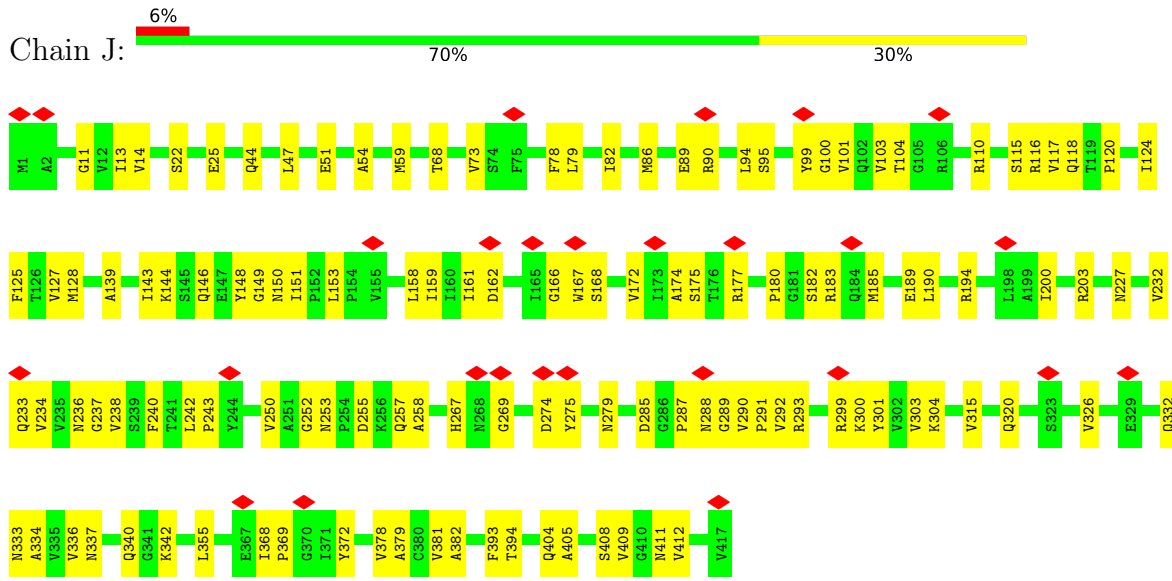

• Molecule 5: Baseplate_J domain-containing protein gp44

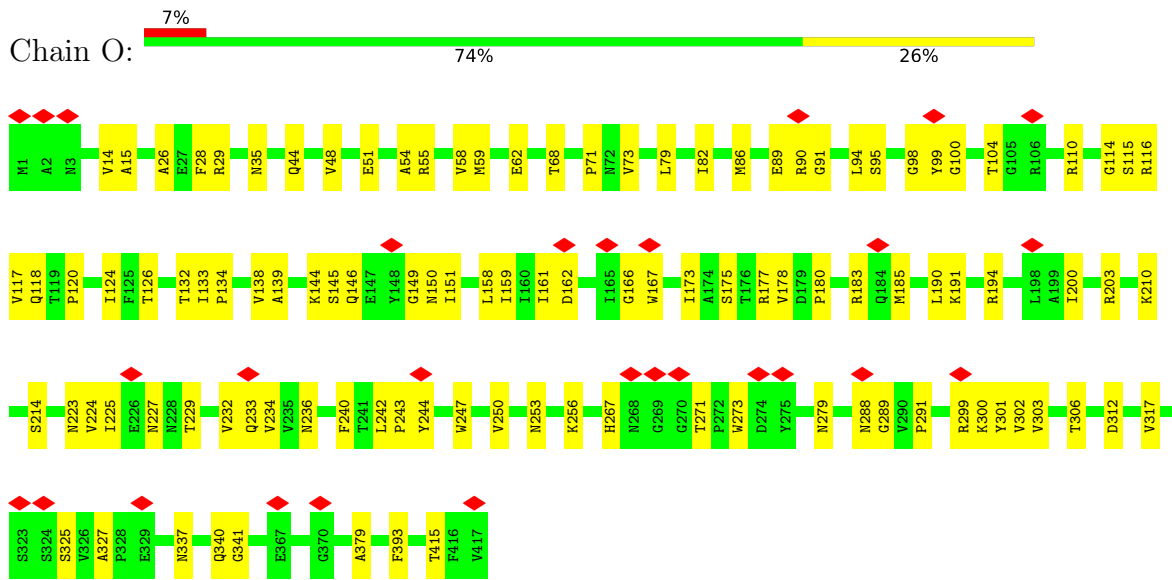

• Molecule 5: Baseplate_J domain-containing protein gp44

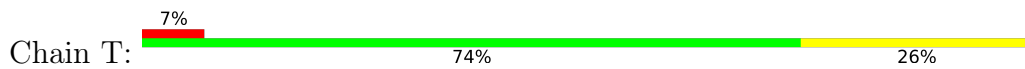

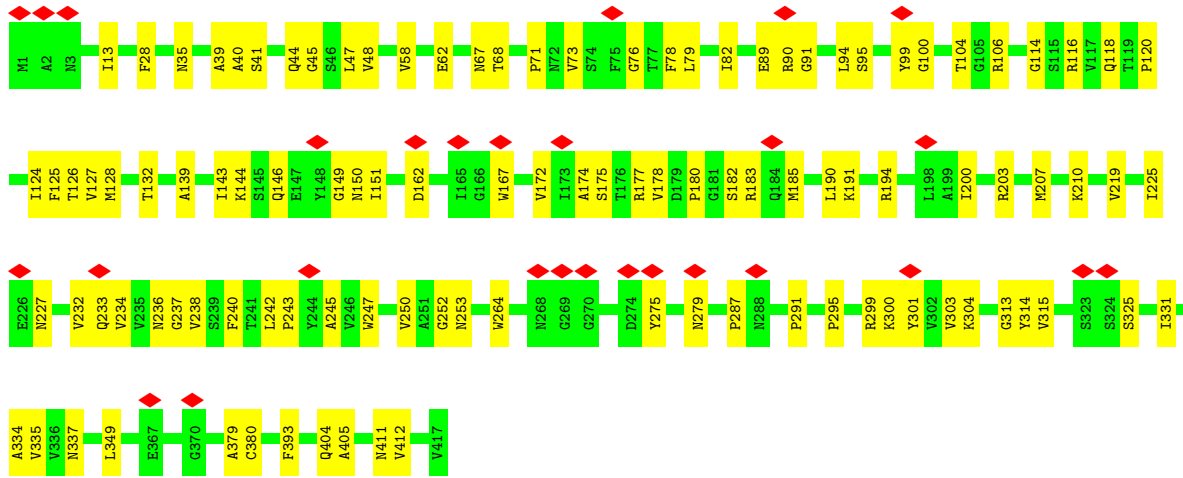

• Molecule 5: Baseplate_J domain-containing protein gp44

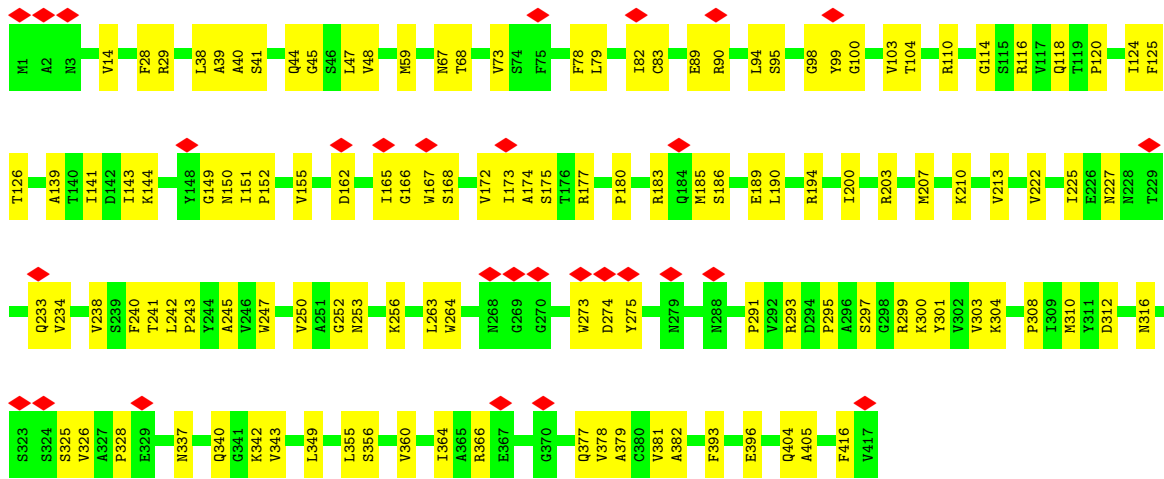

• Molecule 5: Baseplate_J domain-containing protein gp44

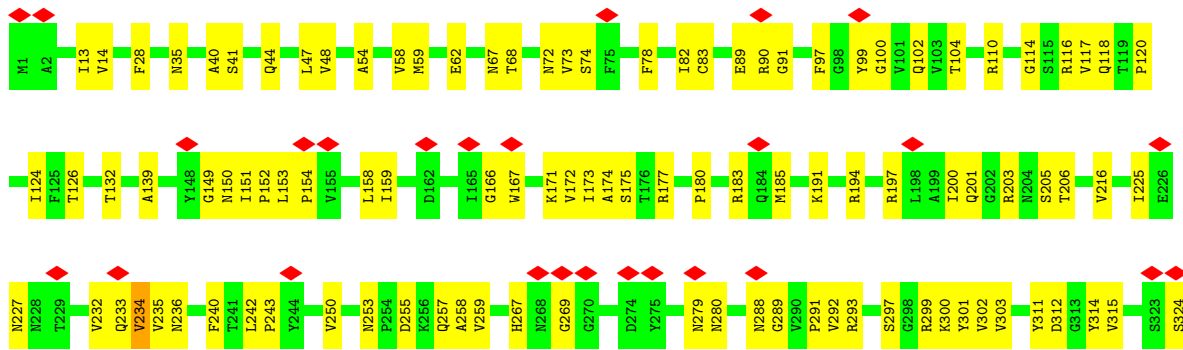
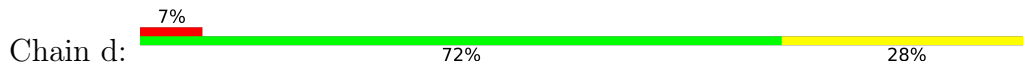

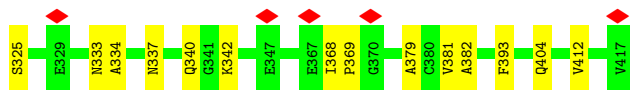

• Molecule 5: Baseplate_J domain-containing protein gp44

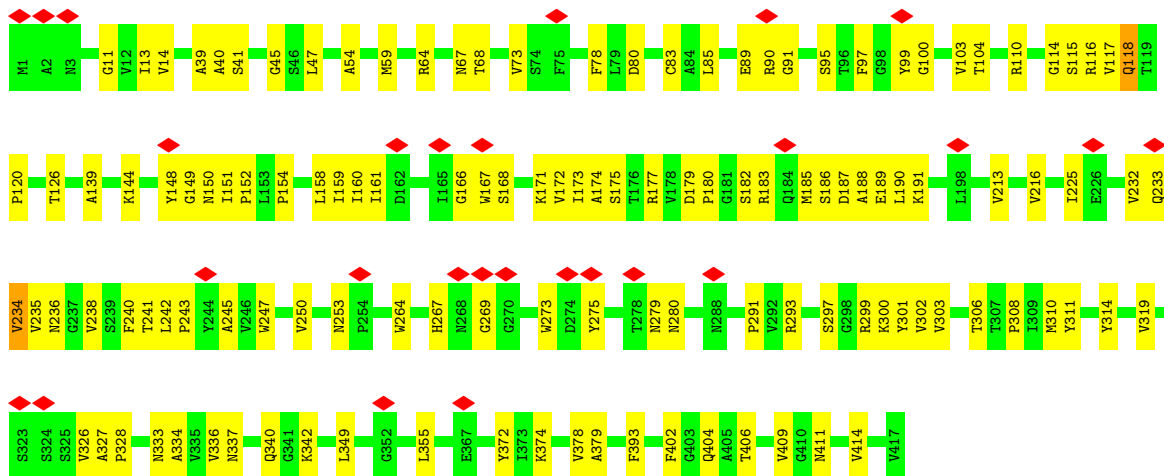

• Molecule 6: Structural protein gp45

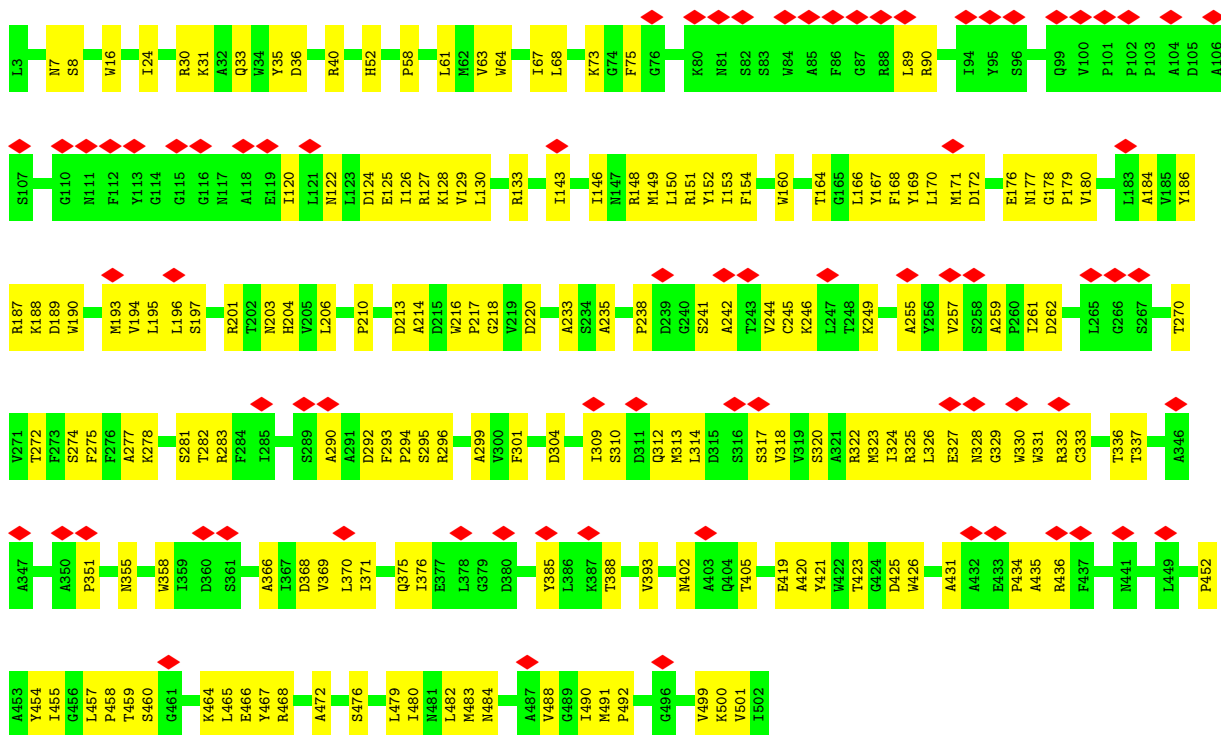

• Molecule 6: Structural protein gp45

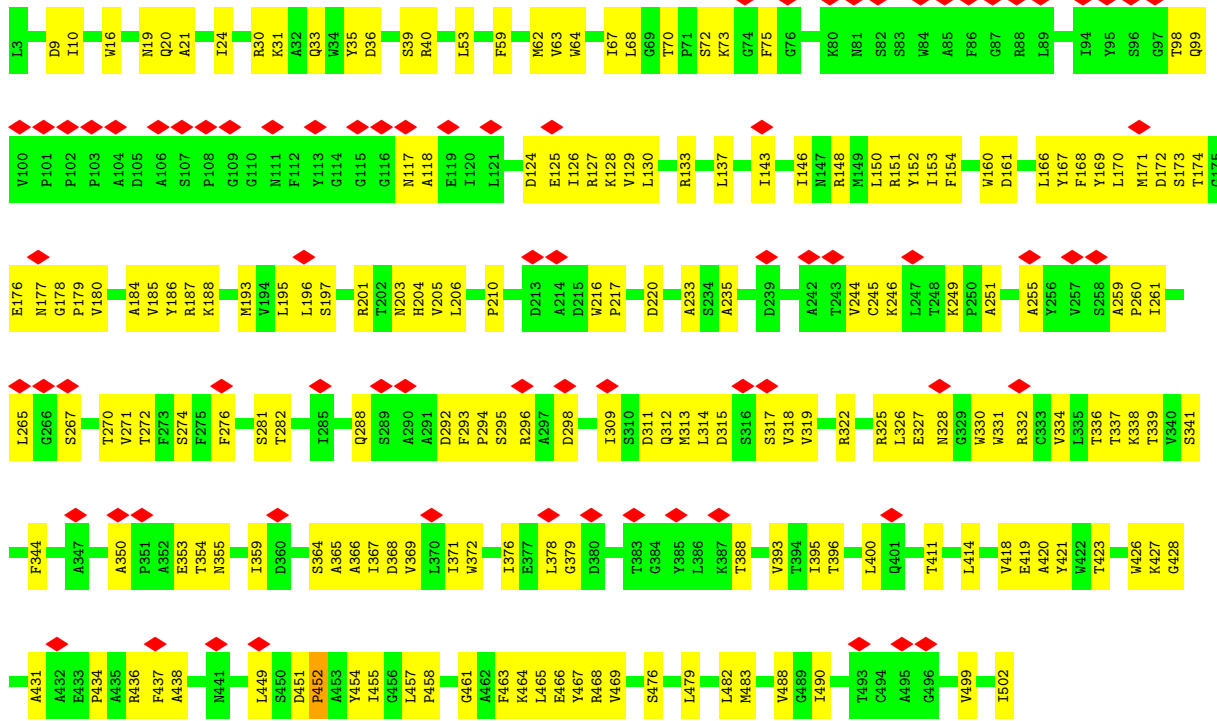

• Molecule 6: Structural protein gp45

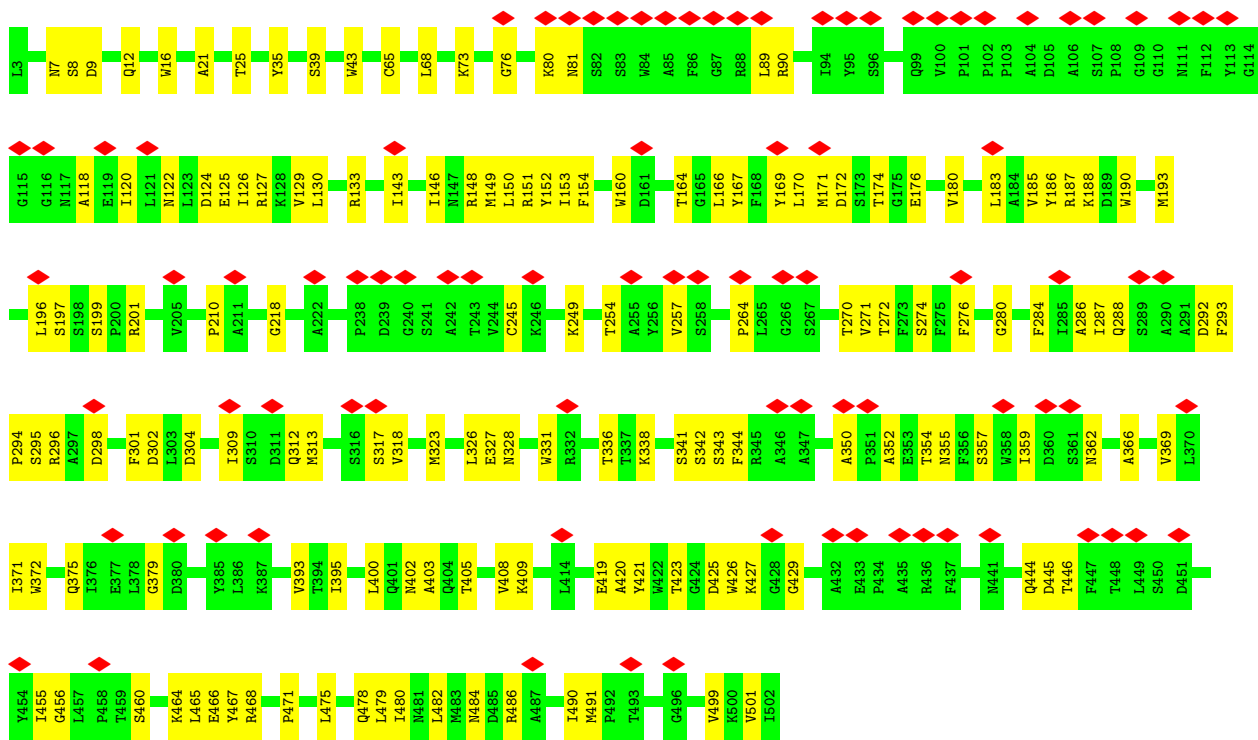

• Molecule 6: Structural protein gp45

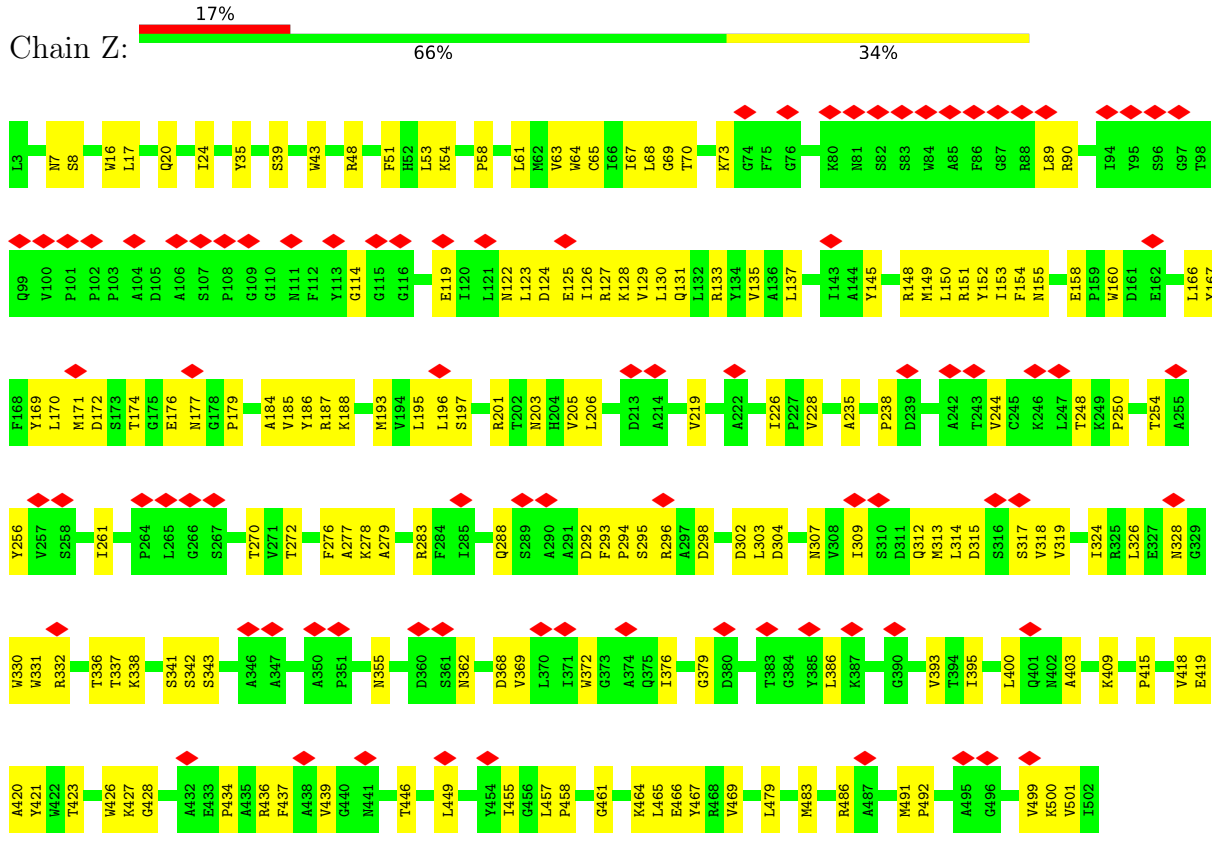

• Molecule 6: Structural protein gp45

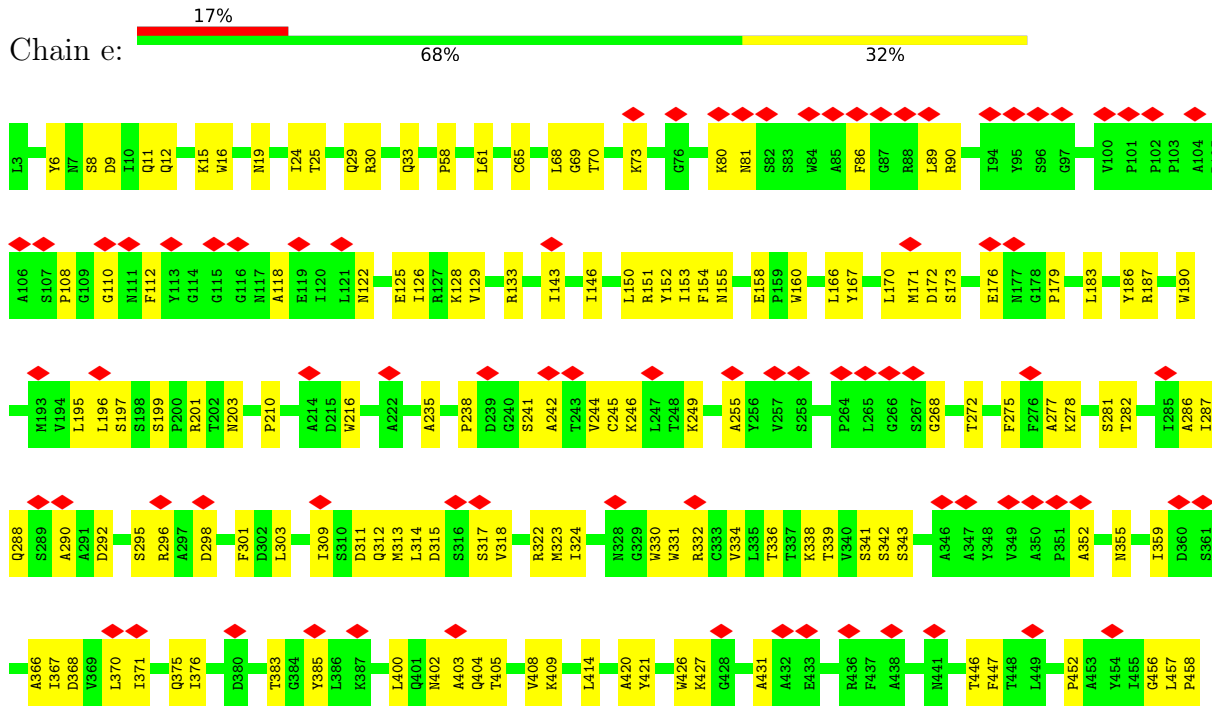

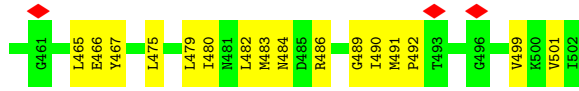

• Molecule 6: Structural protein gp45

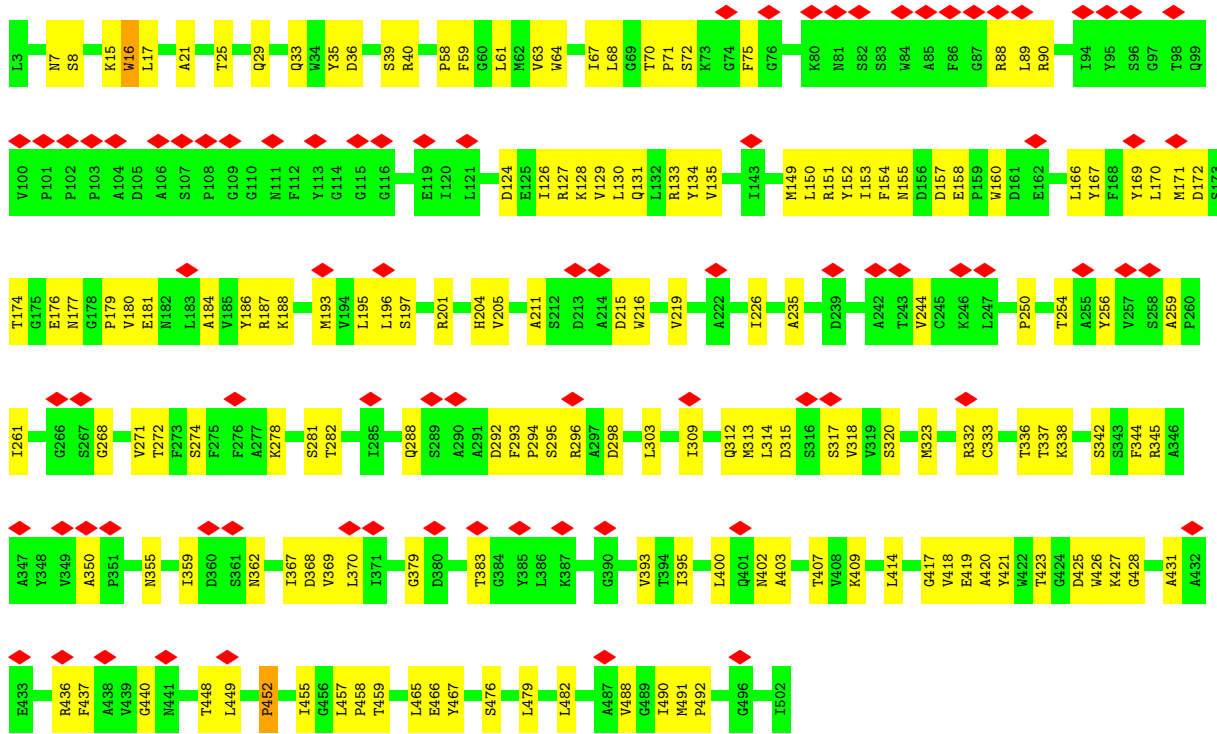

4 Experimental information

Property	Value	Source
EM reconstruction method	SINGLE PARTICLE	Depositor
Imposed symmetry	POINT, C6	Depositor
Number of particles used	9300	Depositor
Resolution determination method	FSC 0.143 CUT-OFF	Depositor
CTF correction method	PHASE FLIPPING AND AMPLITUDE CORRECTION	Depositor
Microscope	TFS KRIOS	Depositor
Voltage (kV)	300	Depositor
Electron dose ($e^-/\text{\AA}^2$)	50	Depositor
Minimum defocus (nm)	500	Depositor
Maximum defocus (nm)	1500	Depositor
Magnification	81000	Depositor
Image detector	GATAN K3 (6k x 4k)	Depositor
Maximum map value	0.091	Depositor
Minimum map value	-0.063	Depositor
Average map value	-0.000	Depositor
Map value standard deviation	0.005	Depositor
Recommended contour level	0.01	Depositor
Map size (Å)	448.0, 448.0, 448.0	wwPDB
Map dimensions	400, 400, 400	wwPDB
Map angles (°)	90.0, 90.0, 90.0	wwPDB
Pixel spacing (Å)	1.12, 1.12, 1.12	Depositor

5 Model quality

5.1 Standard geometry

The Z score for a bond length (or angle) is the number of standard deviations the observed value is removed from the expected value. A bond length (or angle) with $|Z| > 5$ is considered an outlier worth inspection. RMSZ is the root-mean-square of all Z scores of the bond lengths (or angles).

Mol	Chain	Bond lengths		Bond angles	
		RMSZ	# $ Z > 5$	RMSZ	# $ Z > 5$
1	A	0.19	0/3849	0.34	0/5259
1	B	0.19	0/3849	0.34	0/5259
1	C	0.20	0/3849	0.35	0/5259
1	D	0.20	0/3849	0.34	0/5259
1	E	0.20	0/3849	0.34	0/5259
1	F	0.20	0/3849	0.35	0/5259
2	G	0.20	0/839	0.39	0/1139
2	L	0.18	0/839	0.34	0/1139
2	Q	0.18	0/839	0.37	0/1139
2	V	0.19	0/839	0.38	0/1139
2	a	0.20	0/839	0.40	0/1139
2	f	0.18	0/839	0.36	0/1139
3	H	0.20	0/832	0.36	0/1128
3	M	0.20	0/832	0.39	0/1128
3	R	0.20	0/832	0.37	0/1128
3	W	0.20	0/832	0.40	0/1128
3	b	0.20	0/832	0.35	0/1128
3	g	0.20	0/832	0.37	0/1128
4	I	0.24	0/1155	0.40	0/1563
4	N	0.22	0/1155	0.33	0/1563
4	S	0.23	0/1155	0.38	0/1563
4	X	0.23	0/1155	0.34	0/1563
4	c	0.25	0/1155	0.39	0/1563
4	h	0.23	0/1155	0.37	0/1563
5	J	0.16	0/3090	0.37	0/4225
5	O	0.16	0/3090	0.36	0/4225
5	T	0.16	0/3090	0.36	0/4225
5	Y	0.16	0/3090	0.38	1/4225 (0.0%)
5	d	0.17	0/3090	0.39	1/4225 (0.0%)
5	i	0.17	0/3090	0.39	1/4225 (0.0%)
6	K	0.14	0/3922	0.39	0/5363
6	P	0.23	1/3922 (0.0%)	0.45	3/5363 (0.1%)
6	U	0.15	0/3922	0.39	2/5363 (0.0%)
6	Z	0.15	0/3922	0.41	0/5363

Mol	Chain	Bond lengths		Bond angles	
		RMSZ	# Z >5	RMSZ	# Z >5
6	e	0.14	0/3922	0.37	0/5363
6	j	0.15	0/3922	0.40	2/5363 (0.0%)
All	All	0.18	1/82122 (0.0%)	0.37	10/112062 (0.0%)

Chiral center outliers are detected by calculating the chiral volume of a chiral center and verifying if the center is modelled as a planar moiety or with the opposite hand. A planarity outlier is detected by checking planarity of atoms in a peptide group, atoms in a mainchain group or atoms of a sidechain that are expected to be planar.

Mol	Chain	#Chirality outliers	#Planarity outliers
2	G	0	1
2	L	0	1
2	Q	0	1
2	V	0	1
2	a	0	1
2	f	0	1
5	i	0	1
6	j	0	1
All	All	0	8

All (1) bond length outliers are listed below:

Mol	Chain	Res	Type	Atoms	Z	Observed(Å)	Ideal(Å)
6	P	452	PRO	CG-CD	-10.50	1.15	1.50

The worst 5 of 10 bond angle outliers are listed below:

Mol	Chain	Res	Type	Atoms	Z	Observed(°)	Ideal(°)
6	P	452	PRO	N-CD-CG	-13.70	82.65	103.20
6	P	452	PRO	CA-CB-CG	-7.36	90.52	104.50
5	Y	238	VAL	N-CA-C	-7.15	106.34	113.20
6	U	264	PRO	N-CD-CG	-6.82	95.62	103.80
6	P	452	PRO	CA-N-CD	-6.48	102.93	112.00

There are no chirality outliers.

5 of 8 planarity outliers are listed below:

Mol	Chain	Res	Type	Group
2	G	65	ARG	Peptide
2	L	65	ARG	Peptide
2	Q	65	ARG	Peptide

Continued on next page...

Continued from previous page...

Mol	Chain	Res	Type	Group
2	V	65	ARG	Peptide
2	a	65	ARG	Peptide

5.2 Too-close contacts [i](#)

In the following table, the Non-H and H(model) columns list the number of non-hydrogen atoms and hydrogen atoms in the chain respectively. The H(added) column lists the number of hydrogen atoms added and optimized by MolProbity. The Clashes column lists the number of clashes within the asymmetric unit, whereas Symm-Clashes lists symmetry-related clashes.

Mol	Chain	Non-H	H(model)	H(added)	Clashes	Symm-Clashes
1	A	3780	0	3708	84	0
1	B	3780	0	3708	91	0
1	C	3780	0	3708	92	0
1	D	3780	0	3708	88	0
1	E	3780	0	3708	97	0
1	F	3780	0	3708	89	0
2	G	816	0	767	17	0
2	L	816	0	767	15	0
2	Q	816	0	767	19	0
2	V	816	0	767	13	0
2	a	816	0	767	21	0
2	f	816	0	767	14	0
3	H	823	0	800	19	0
3	M	823	0	800	20	0
3	R	823	0	800	17	0
3	W	823	0	800	16	0
3	b	823	0	800	18	0
3	g	823	0	800	23	0
4	I	1133	0	1137	19	0
4	N	1133	0	1137	17	0
4	S	1133	0	1137	14	0
4	X	1133	0	1137	12	0
4	c	1133	0	1137	22	0
4	h	1133	0	1137	19	0
5	J	3036	0	3013	108	0
5	O	3036	0	3013	89	0
5	T	3036	0	3013	90	0
5	Y	3036	0	3013	104	0
5	d	3036	0	3013	112	0
5	i	3036	0	3013	102	0
6	K	3818	0	3706	150	0

Continued on next page...

Continued from previous page...

Mol	Chain	Non-H	H(model)	H(added)	Clashes	Symm-Clashes
6	P	3818	0	3706	165	0
6	U	3818	0	3706	122	0
6	Z	3818	0	3706	146	0
6	e	3818	0	3706	134	0
6	j	3818	0	3706	121	0
All	All	80436	0	78786	2093	0

The all-atom clashscore is defined as the number of clashes found per 1000 atoms (including hydrogen atoms). The all-atom clashscore for this structure is 13.

The worst 5 of 2093 close contacts within the same asymmetric unit are listed below, sorted by their clash magnitude.

Atom-1	Atom-2	Interatomic distance (Å)	Clash overlap (Å)
6:Z:148:ARG:HH21	6:Z:149:MET:HE2	1.28	0.97
6:U:151:ARG:HG3	6:U:160:TRP:HE1	1.31	0.93
5:d:299:ARG:NH2	6:e:171:MET:SD	2.42	0.93
6:Z:151:ARG:HG3	6:Z:160:TRP:HE1	1.34	0.92
6:K:186:TYR:HB2	6:K:421:TYR:HB2	1.52	0.89

There are no symmetry-related clashes.

5.3 Torsion angles [i](#)

5.3.1 Protein backbone [i](#)

In the following table, the Percentiles column shows the percent Ramachandran outliers of the chain as a percentile score with respect to all PDB entries followed by that with respect to all EM entries.

The Analysed column shows the number of residues for which the backbone conformation was analysed, and the total number of residues.

Mol	Chain	Analysed	Favoured	Allowed	Outliers	Percentiles
1	A	502/504 (100%)	485 (97%)	16 (3%)	1 (0%)	43 71
1	B	502/504 (100%)	487 (97%)	14 (3%)	1 (0%)	43 71
1	C	502/504 (100%)	479 (95%)	22 (4%)	1 (0%)	43 71
1	D	502/504 (100%)	483 (96%)	18 (4%)	1 (0%)	43 71
1	E	502/504 (100%)	478 (95%)	23 (5%)	1 (0%)	43 71

Continued on next page...

Continued from previous page...

Mol	Chain	Analysed	Favoured	Allowed	Outliers	Percentiles	
1	F	502/504 (100%)	477 (95%)	24 (5%)	1 (0%)	43	71
2	G	100/102 (98%)	94 (94%)	6 (6%)	0	100	100
2	L	100/102 (98%)	95 (95%)	5 (5%)	0	100	100
2	Q	100/102 (98%)	94 (94%)	6 (6%)	0	100	100
2	V	100/102 (98%)	93 (93%)	7 (7%)	0	100	100
2	a	100/102 (98%)	94 (94%)	6 (6%)	0	100	100
2	f	100/102 (98%)	93 (93%)	7 (7%)	0	100	100
3	H	106/108 (98%)	96 (91%)	8 (8%)	2 (2%)	6	26
3	M	106/108 (98%)	97 (92%)	7 (7%)	2 (2%)	6	26
3	R	106/108 (98%)	97 (92%)	7 (7%)	2 (2%)	6	26
3	W	106/108 (98%)	95 (90%)	10 (9%)	1 (1%)	14	41
3	b	106/108 (98%)	96 (91%)	8 (8%)	2 (2%)	6	26
3	g	106/108 (98%)	94 (89%)	11 (10%)	1 (1%)	14	41
4	I	150/152 (99%)	142 (95%)	6 (4%)	2 (1%)	9	33
4	N	150/152 (99%)	141 (94%)	9 (6%)	0	100	100
4	S	150/152 (99%)	139 (93%)	9 (6%)	2 (1%)	9	33
4	X	150/152 (99%)	141 (94%)	9 (6%)	0	100	100
4	c	150/152 (99%)	143 (95%)	6 (4%)	1 (1%)	18	47
4	h	150/152 (99%)	143 (95%)	5 (3%)	2 (1%)	9	33
5	J	415/417 (100%)	373 (90%)	42 (10%)	0	100	100
5	O	415/417 (100%)	361 (87%)	54 (13%)	0	100	100
5	T	415/417 (100%)	368 (89%)	47 (11%)	0	100	100
5	Y	415/417 (100%)	368 (89%)	47 (11%)	0	100	100
5	d	415/417 (100%)	361 (87%)	54 (13%)	0	100	100
5	i	415/417 (100%)	365 (88%)	50 (12%)	0	100	100
6	K	498/500 (100%)	461 (93%)	36 (7%)	1 (0%)	43	71
6	P	498/500 (100%)	458 (92%)	39 (8%)	1 (0%)	43	71
6	U	498/500 (100%)	457 (92%)	41 (8%)	0	100	100
6	Z	498/500 (100%)	458 (92%)	40 (8%)	0	100	100
6	e	498/500 (100%)	460 (92%)	38 (8%)	0	100	100
6	j	498/500 (100%)	461 (93%)	37 (7%)	0	100	100

Continued on next page...

Continued from previous page...

Mol	Chain	Analysed	Favoured	Allowed	Outliers	Percentiles
All	All	10626/10698 (99%)	9827 (92%)	774 (7%)	25 (0%)	44 71

5 of 25 Ramachandran outliers are listed below:

Mol	Chain	Res	Type
1	A	2	ILE
1	C	2	ILE
1	D	2	ILE
1	F	2	ILE
4	S	89	PHE

5.3.2 Protein sidechains [i](#)

In the following table, the Percentiles column shows the percent sidechain outliers of the chain as a percentile score with respect to all PDB entries followed by that with respect to all EM entries.

The Analysed column shows the number of residues for which the sidechain conformation was analysed, and the total number of residues.

Mol	Chain	Analysed	Rotameric	Outliers	Percentiles
1	A	400/400 (100%)	400 (100%)	0	100 100
1	B	400/400 (100%)	400 (100%)	0	100 100
1	C	400/400 (100%)	400 (100%)	0	100 100
1	D	400/400 (100%)	400 (100%)	0	100 100
1	E	400/400 (100%)	399 (100%)	1 (0%)	86 84
1	F	400/400 (100%)	400 (100%)	0	100 100
2	G	84/84 (100%)	84 (100%)	0	100 100
2	L	84/84 (100%)	84 (100%)	0	100 100
2	Q	84/84 (100%)	84 (100%)	0	100 100
2	V	84/84 (100%)	84 (100%)	0	100 100
2	a	84/84 (100%)	84 (100%)	0	100 100
2	f	84/84 (100%)	84 (100%)	0	100 100
3	H	92/92 (100%)	92 (100%)	0	100 100
3	M	92/92 (100%)	91 (99%)	1 (1%)	65 73
3	R	92/92 (100%)	92 (100%)	0	100 100
3	W	92/92 (100%)	92 (100%)	0	100 100

Continued on next page...

Continued from previous page...

Mol	Chain	Analysed	Rotameric	Outliers	Percentiles	
3	b	92/92 (100%)	92 (100%)	0	100	100
3	g	92/92 (100%)	91 (99%)	1 (1%)	65	73
4	I	124/124 (100%)	124 (100%)	0	100	100
4	N	124/124 (100%)	124 (100%)	0	100	100
4	S	124/124 (100%)	124 (100%)	0	100	100
4	X	124/124 (100%)	124 (100%)	0	100	100
4	c	124/124 (100%)	124 (100%)	0	100	100
4	h	124/124 (100%)	124 (100%)	0	100	100
5	J	320/320 (100%)	320 (100%)	0	100	100
5	O	320/320 (100%)	320 (100%)	0	100	100
5	T	320/320 (100%)	320 (100%)	0	100	100
5	Y	320/320 (100%)	320 (100%)	0	100	100
5	d	320/320 (100%)	320 (100%)	0	100	100
5	i	320/320 (100%)	320 (100%)	0	100	100
6	K	404/404 (100%)	404 (100%)	0	100	100
6	P	404/404 (100%)	404 (100%)	0	100	100
6	U	404/404 (100%)	404 (100%)	0	100	100
6	Z	404/404 (100%)	404 (100%)	0	100	100
6	e	404/404 (100%)	404 (100%)	0	100	100
6	j	404/404 (100%)	404 (100%)	0	100	100
All	All	8544/8544 (100%)	8541 (100%)	3 (0%)	100	100

All (3) residues with a non-rotameric sidechain are listed below:

Mol	Chain	Res	Type
1	E	256	ASN
3	M	33	GLN
3	g	33	GLN

Sometimes sidechains can be flipped to improve hydrogen bonding and reduce clashes. 5 of 85 such sidechains are listed below:

Mol	Chain	Res	Type
6	U	288	GLN
6	e	307	ASN

Continued on next page...

Continued from previous page...

Mol	Chain	Res	Type
2	V	63	GLN
5	Y	332	GLN
3	g	64	GLN

5.3.3 RNA [i](#)

There are no RNA molecules in this entry.

5.4 Non-standard residues in protein, DNA, RNA chains [i](#)

There are no non-standard protein/DNA/RNA residues in this entry.

5.5 Carbohydrates [i](#)

There are no oligosaccharides in this entry.

5.6 Ligand geometry [i](#)

There are no ligands in this entry.

5.7 Other polymers [i](#)

There are no such residues in this entry.

5.8 Polymer linkage issues [i](#)

There are no chain breaks in this entry.

6 Map visualisation [i](#)

This section contains visualisations of the EMDB entry EMD-28280. These allow visual inspection of the internal detail of the map and identification of artifacts.

Images derived from a raw map, generated by summing the deposited half-maps, are presented below the corresponding image components of the primary map to allow further visual inspection and comparison with those of the primary map.

6.1 Orthogonal projections [i](#)

6.1.1 Primary map

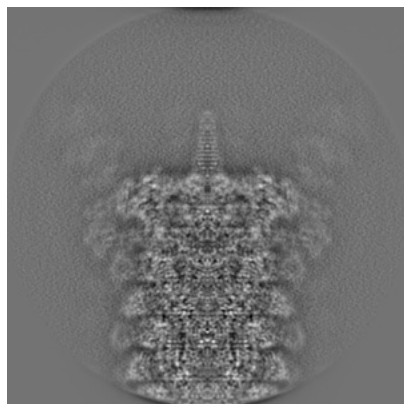

X

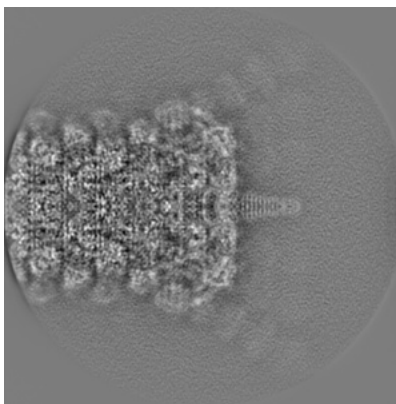

Y

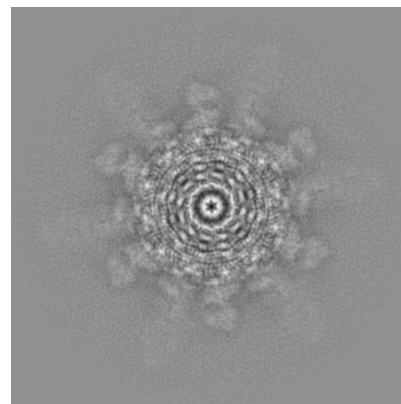

Z

6.1.2 Raw map

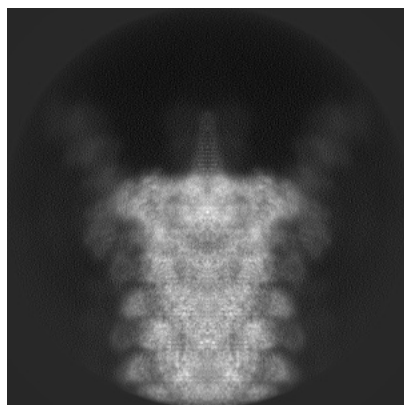

X

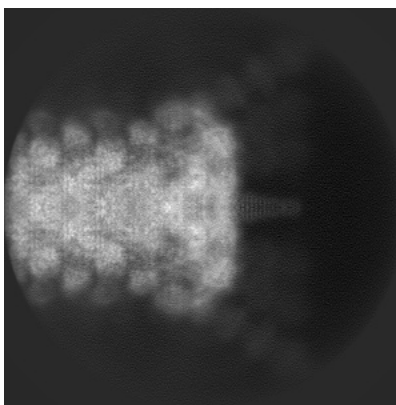

Y

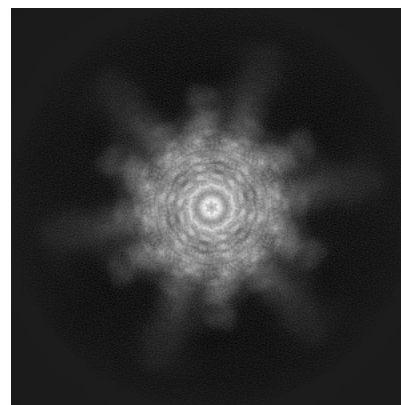

Z

The images above show the map projected in three orthogonal directions.

6.2 Central slices [i](#)

6.2.1 Primary map

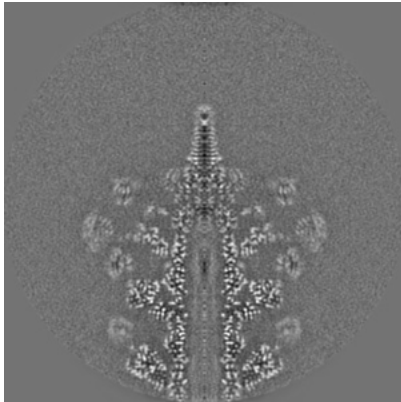

X Index: 200

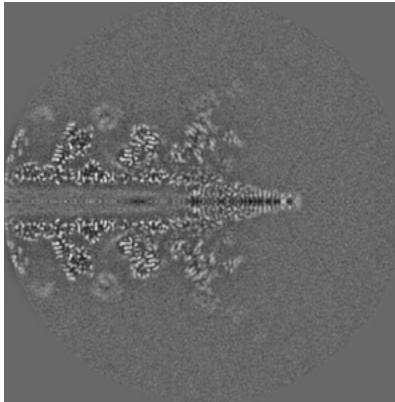

Y Index: 200

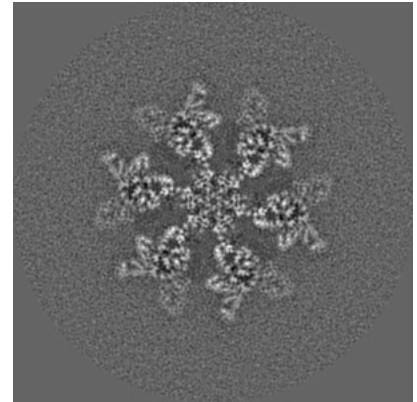

Z Index: 200

6.2.2 Raw map

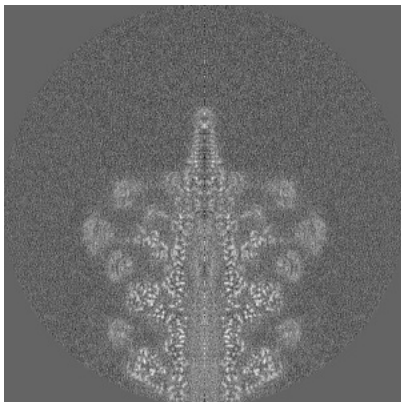

X Index: 200

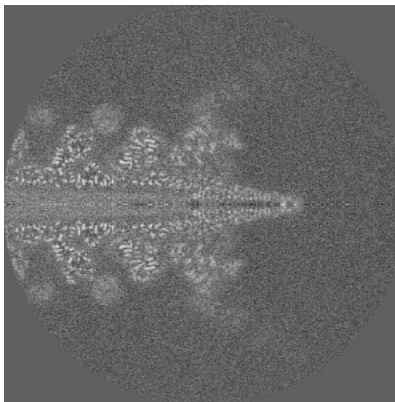

Y Index: 200

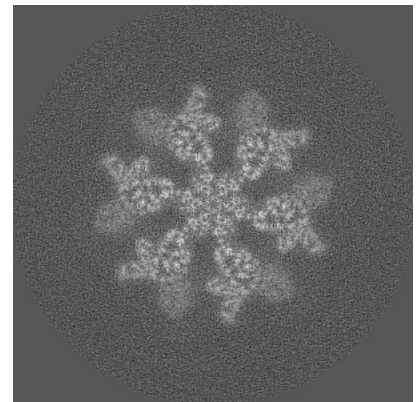

Z Index: 200

The images above show central slices of the map in three orthogonal directions.

6.3 Largest variance slices [i](#)

6.3.1 Primary map

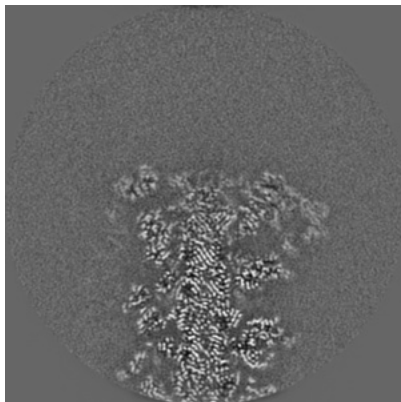

X Index: 180

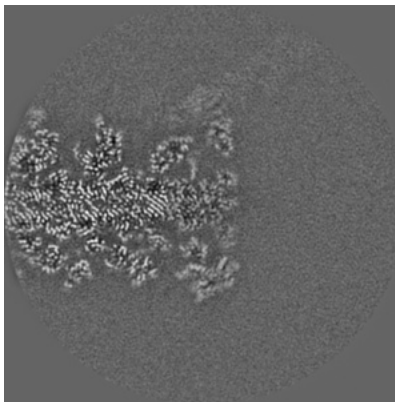

Y Index: 220

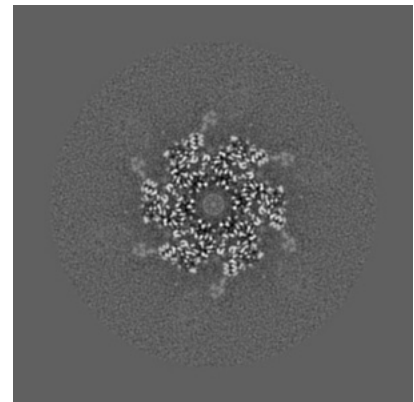

Z Index: 82

6.3.2 Raw map

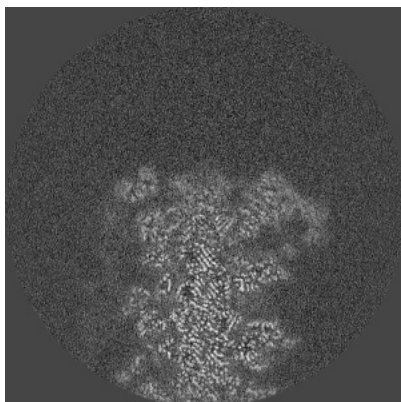

X Index: 179

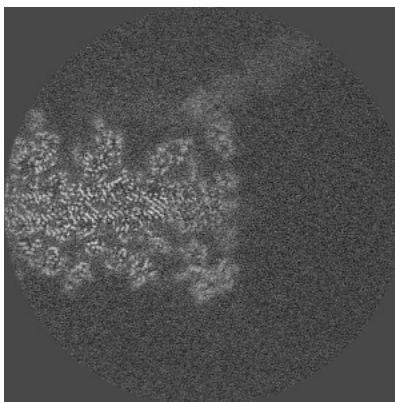

Y Index: 220

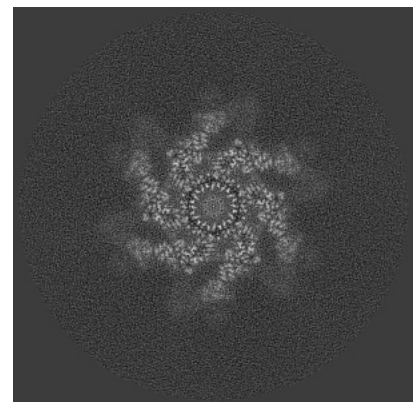

Z Index: 147

The images above show the largest variance slices of the map in three orthogonal directions.

6.4 Orthogonal standard-deviation projections (False-color) [i](#)

6.4.1 Primary map

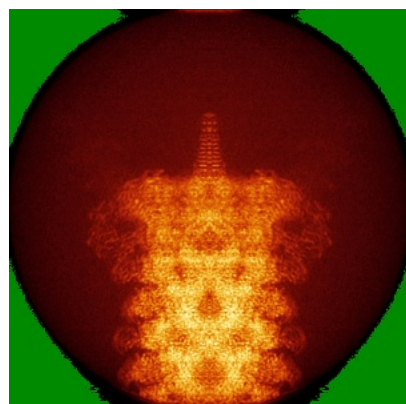

X

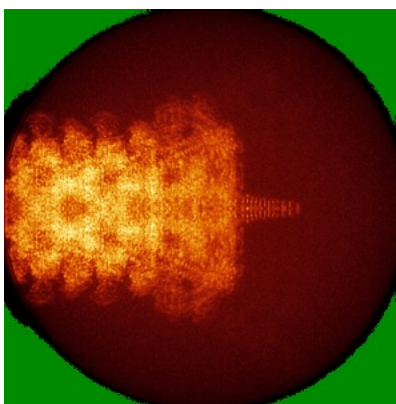

Y

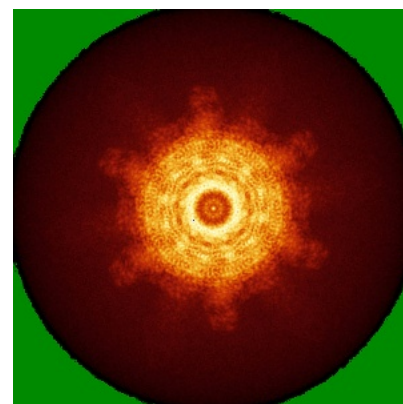

Z

6.4.2 Raw map

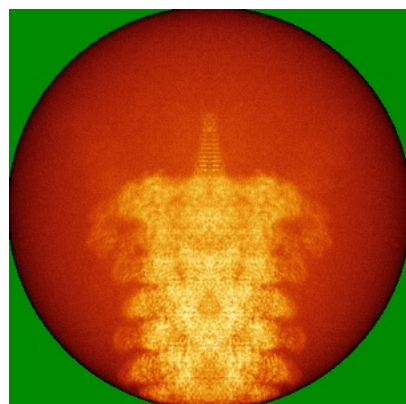

X

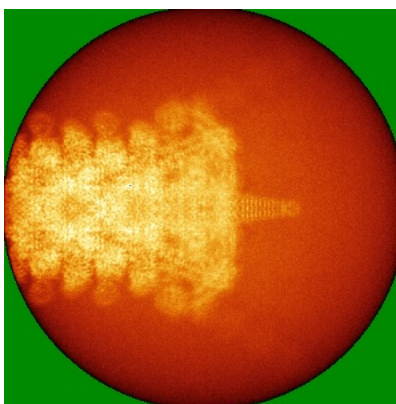

Y

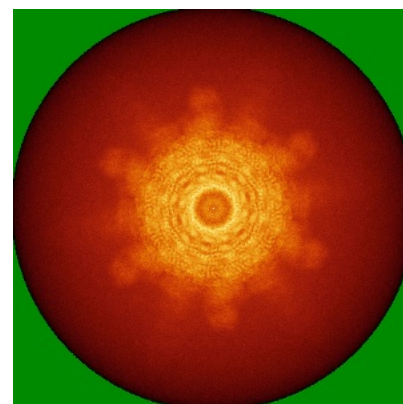

Z

The images above show the map standard deviation projections with false color in three orthogonal directions. Minimum values are shown in green, max in blue, and dark to light orange shades represent small to large values respectively.

6.5 Orthogonal surface views [i](#)

6.5.1 Primary map

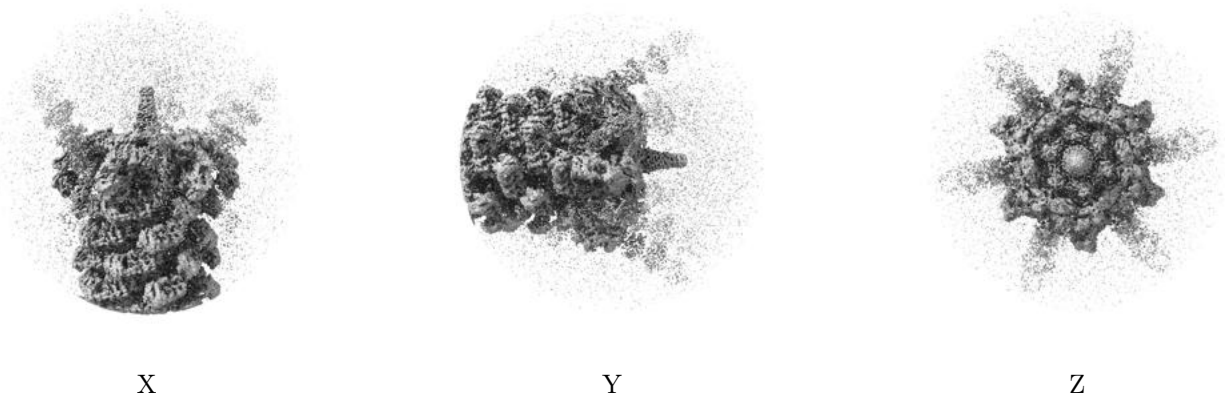

The images above show the 3D surface view of the map at the recommended contour level 0.01. These images, in conjunction with the slice images, may facilitate assessment of whether an appropriate contour level has been provided.

6.5.2 Raw map

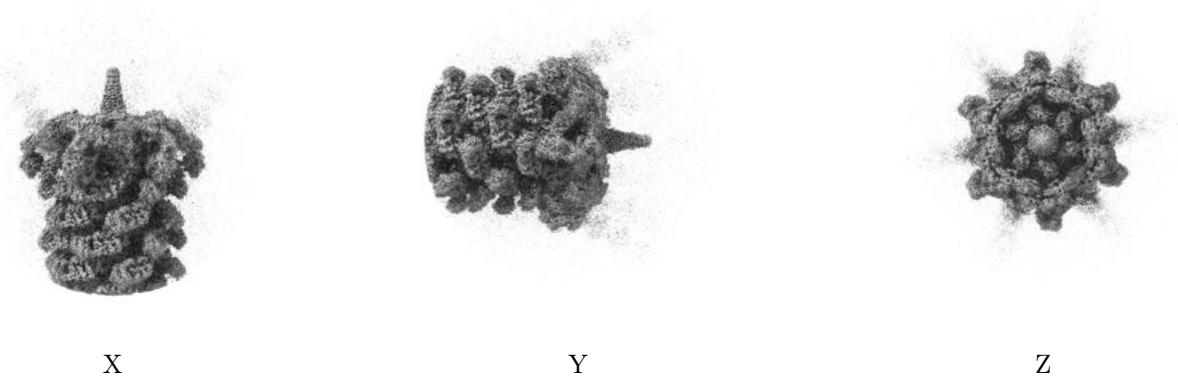

These images show the 3D surface of the raw map. The raw map's contour level was selected so that its surface encloses the same volume as the primary map does at its recommended contour level.

6.6 Mask visualisation [i](#)

This section was not generated. No masks/segmentation were deposited.

7 Map analysis [i](#)

This section contains the results of statistical analysis of the map.

7.1 Map-value distribution [i](#)

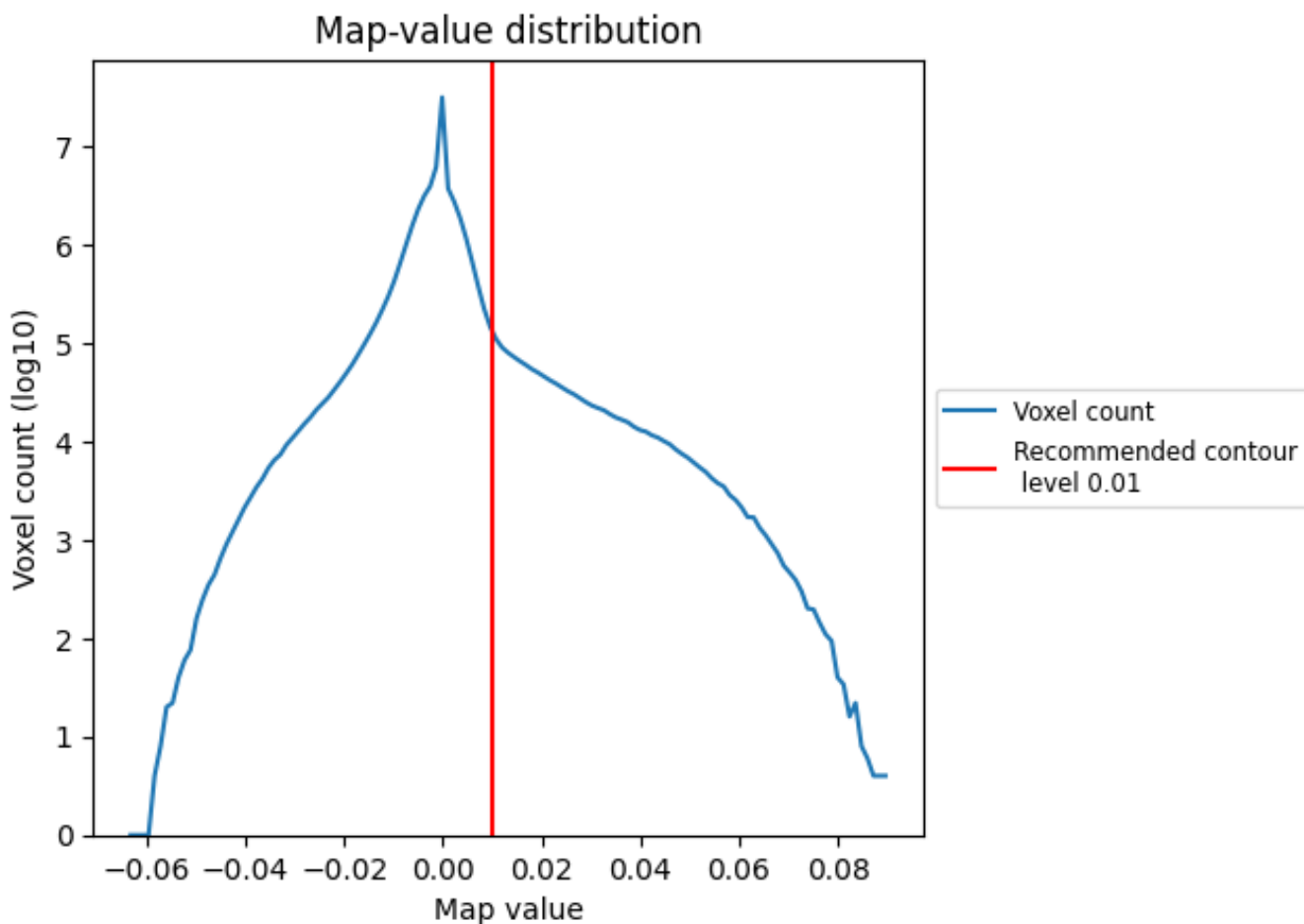

The map-value distribution is plotted in 128 intervals along the x-axis. The y-axis is logarithmic. A spike in this graph at zero usually indicates that the volume has been masked.

7.2 Volume estimate [i](#)

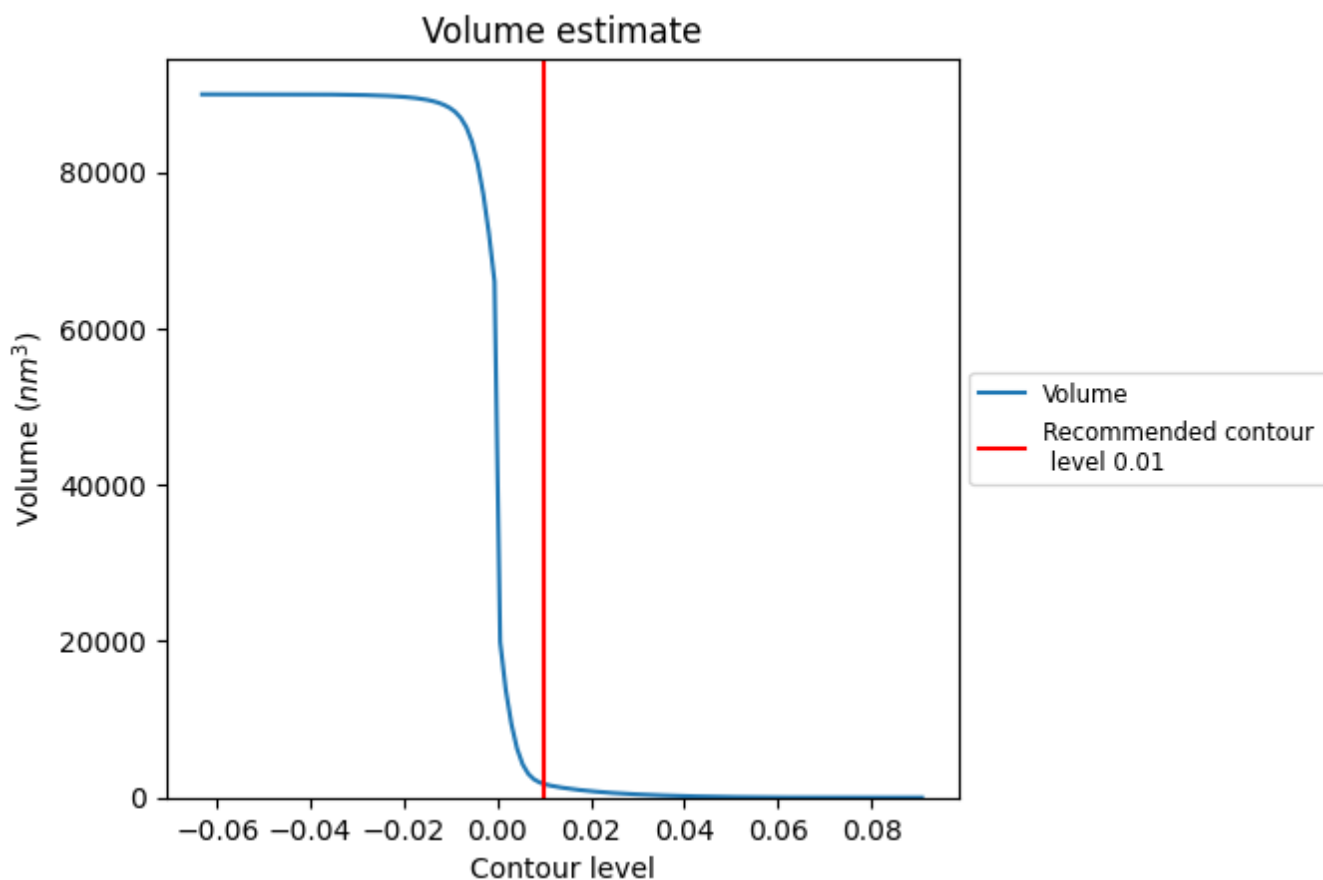

The volume at the recommended contour level is 1739 nm³; this corresponds to an approximate mass of 1571 kDa.

The volume estimate graph shows how the enclosed volume varies with the contour level. The recommended contour level is shown as a vertical line and the intersection between the line and the curve gives the volume of the enclosed surface at the given level.

7.3 Rotationally averaged power spectrum [i](#)

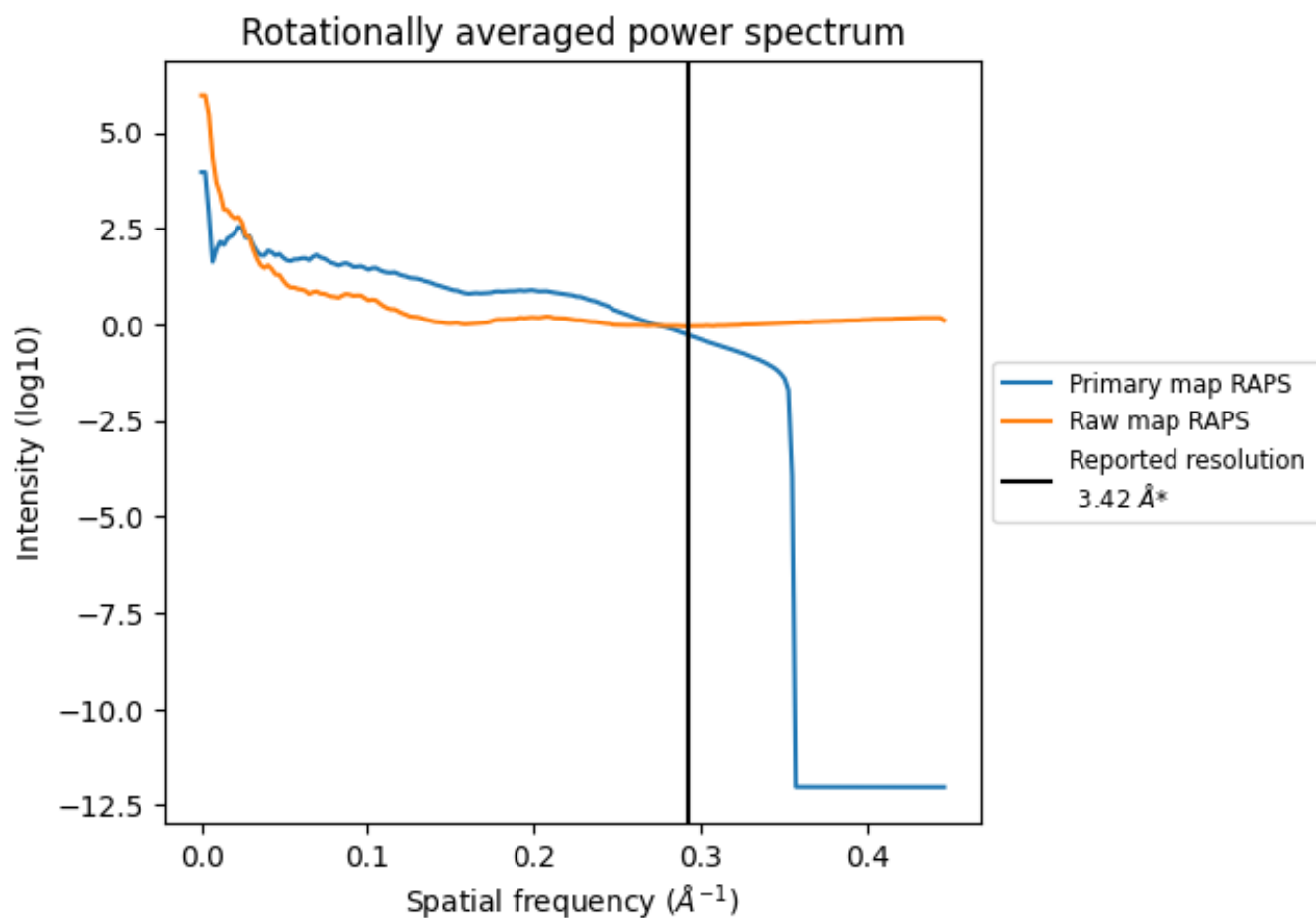

*Reported resolution corresponds to spatial frequency of 0.292 Å⁻¹

8 Fourier-Shell correlation [i](#)

Fourier-Shell Correlation (FSC) is the most commonly used method to estimate the resolution of single-particle and subtomogram-averaged maps. The shape of the curve depends on the imposed symmetry, mask and whether or not the two 3D reconstructions used were processed from a common reference. The reported resolution is shown as a black line. A curve is displayed for the half-bit criterion in addition to lines showing the 0.143 gold standard cut-off and 0.5 cut-off.

8.1 FSC [i](#)

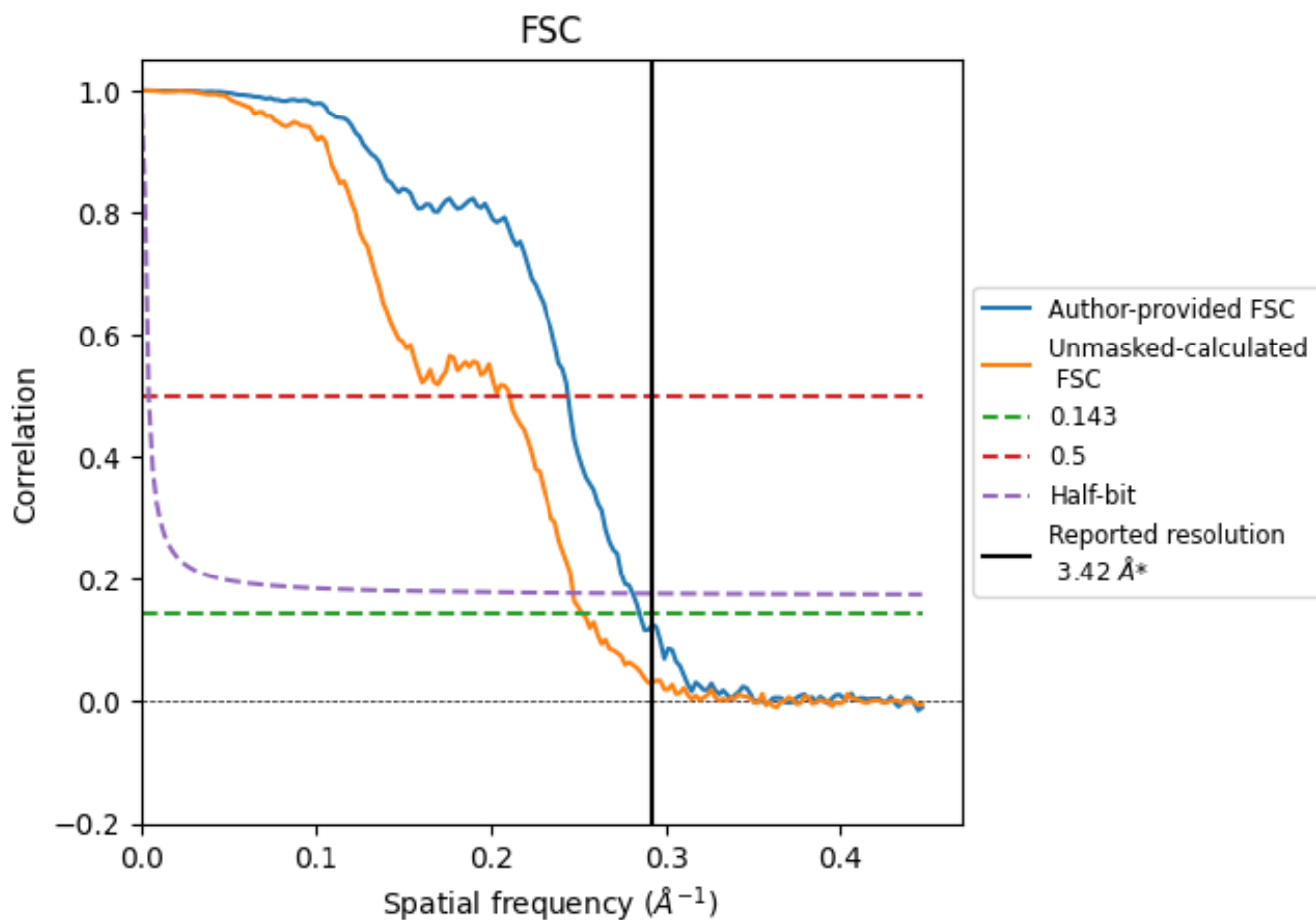

*Reported resolution corresponds to spatial frequency of 0.292 Å⁻¹

8.2 Resolution estimates

Resolution estimate (Å)	Estimation criterion (FSC cut-off)		
	0.143	0.5	Half-bit
Reported by author	3.42	-	-
Author-provided FSC curve	3.51	4.10	3.56
Unmasked-calculated*	3.96	4.75	4.05

*Resolution estimate based on FSC curve calculated by comparison of deposited half-maps. The value from deposited half-maps intersecting FSC 0.143 CUT-OFF 3.96 differs from the reported value 3.42 by more than 10 %

9 Map-model fit [i](#)

This section contains information regarding the fit between EMDB map EMD-28280 and PDB model 8ENV. Per-residue inclusion information can be found in section 3 on page 8.

9.1 Map-model overlay [i](#)

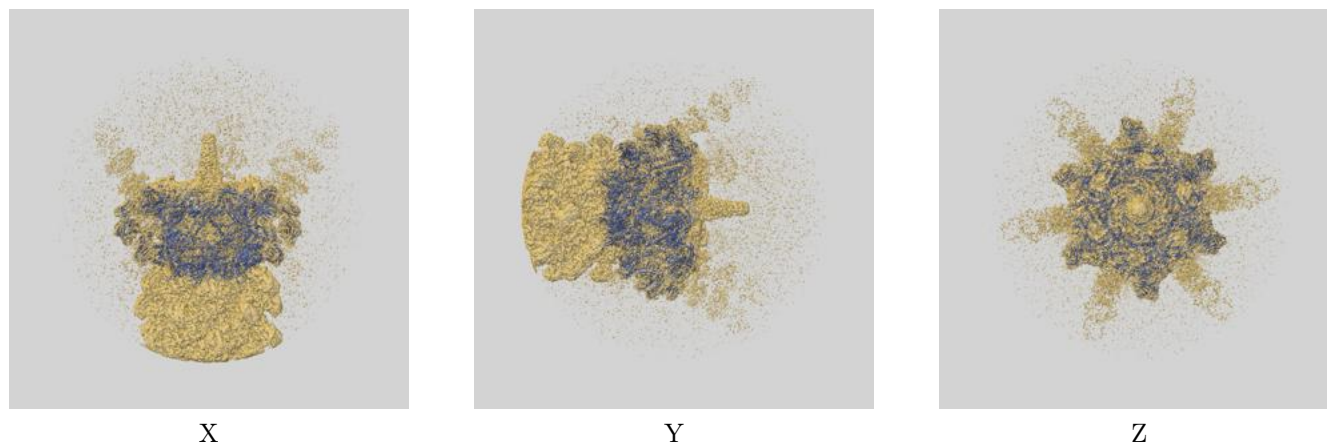

The images above show the 3D surface view of the map at the recommended contour level 0.01 at 50% transparency in yellow overlaid with a ribbon representation of the model coloured in blue. These images allow for the visual assessment of the quality of fit between the atomic model and the map.

9.2 Q-score mapped to coordinate model [i](#)

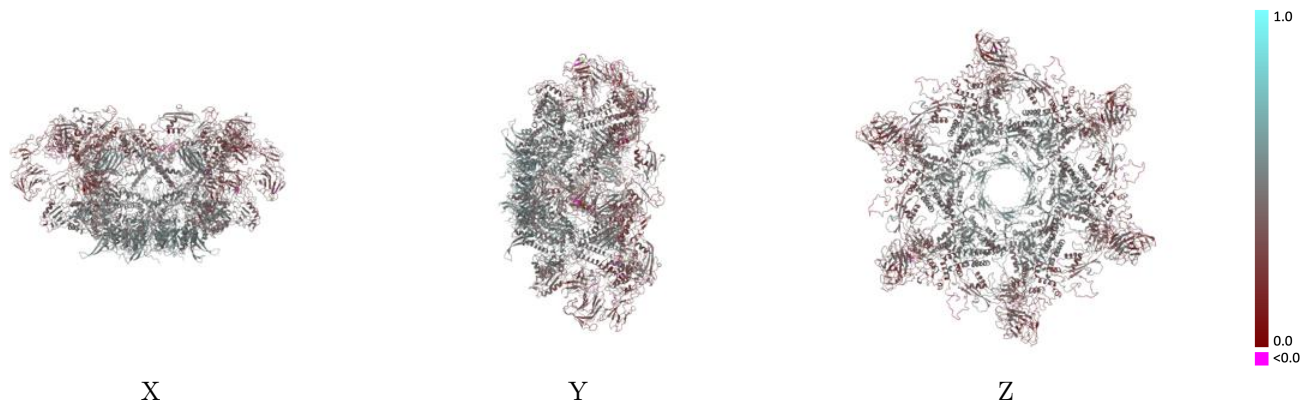

The images above show the model with each residue coloured according to its Q-score. This shows their resolvability in the map with higher Q-score values reflecting better resolvability. Please note: Q-score is calculating the resolvability of atoms, and thus high values are only expected at resolutions at which atoms can be resolved. Low Q-score values may therefore be expected for many entries.

9.3 Atom inclusion mapped to coordinate model [i](#)

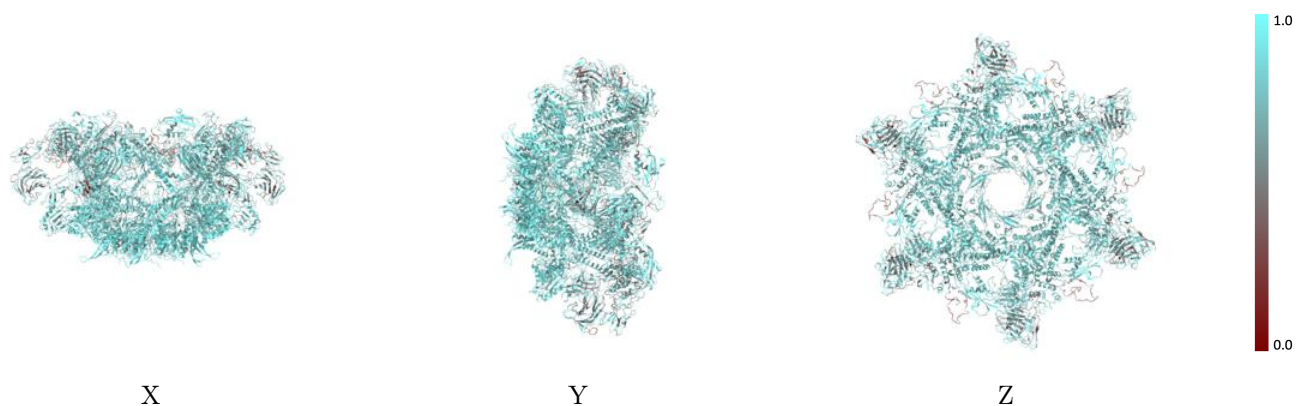

The images above show the model with each residue coloured according to its atom inclusion. This shows to what extent they are inside the map at the recommended contour level (0.01).



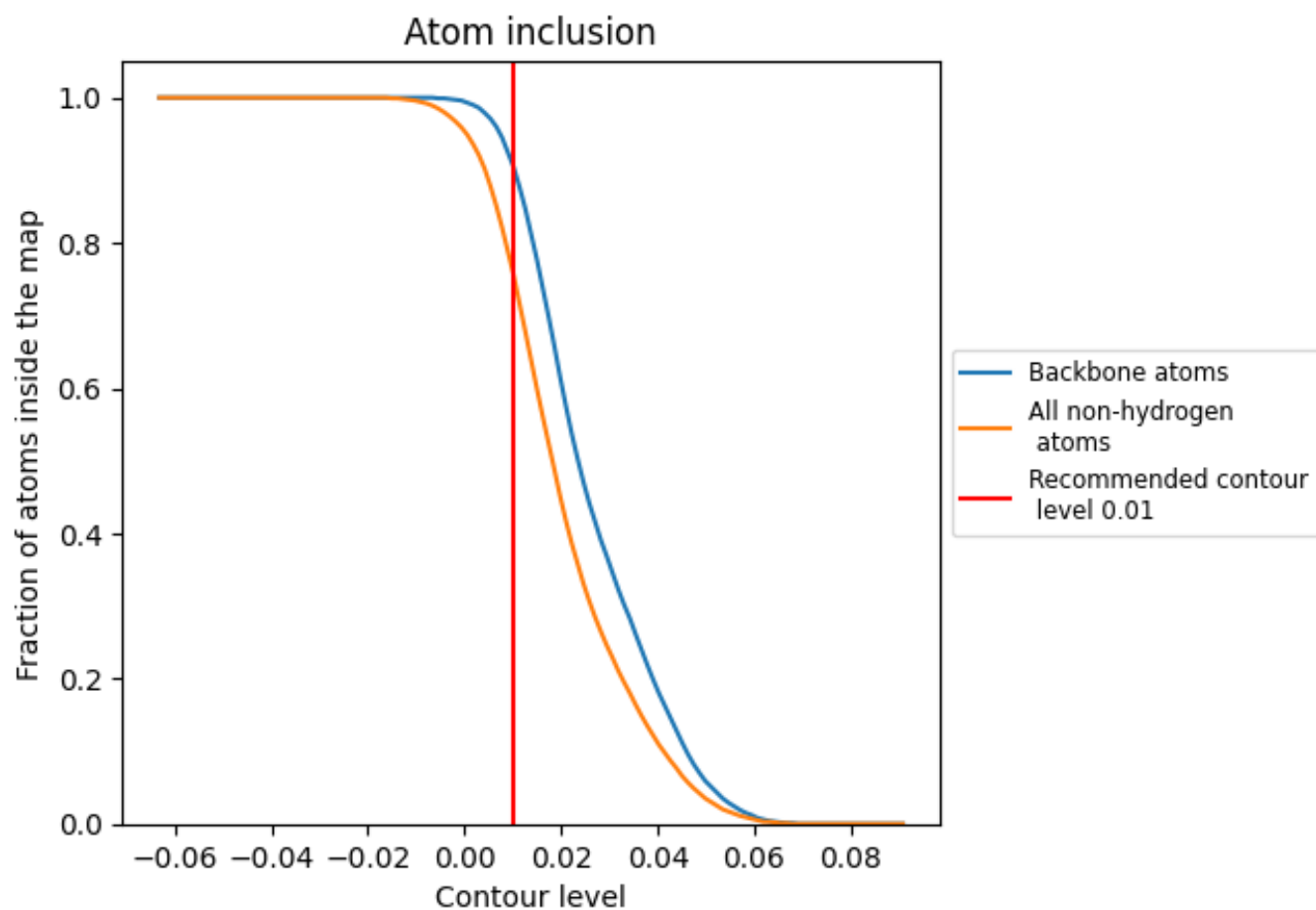



































































9.4 Atom inclusion [i](#)



At the recommended contour level, 91% of all backbone atoms, 76% of all non-hydrogen atoms, are inside the map.

9.5 Map-model fit summary

The table lists the average atom inclusion at the recommended contour level (0.01) and Q-score for the entire model and for each chain.

Chain	Atom inclusion	Q-score
All	 0.7610	 0.4130
A	 0.8390	 0.4620
B	 0.8410	 0.4620
C	 0.8350	 0.4620
D	 0.8340	 0.4610
E	 0.8340	 0.4620
F	 0.8380	 0.4640
G	 0.8330	 0.4750
H	 0.8250	 0.4840
I	 0.8270	 0.5140
J	 0.7360	 0.3740
K	 0.6560	 0.3310
L	 0.8490	 0.4830
M	 0.8270	 0.4850
N	 0.8230	 0.5100
O	 0.7350	 0.3750
P	 0.6560	 0.3340
Q	 0.8310	 0.4860
R	 0.8240	 0.4810
S	 0.8330	 0.5160
T	 0.7370	 0.3770
U	 0.6460	 0.3350
V	 0.8490	 0.4810
W	 0.8310	 0.4850
X	 0.8280	 0.5150
Y	 0.7390	 0.3750
Z	 0.6570	 0.3360
a	 0.8420	 0.4810
b	 0.8270	 0.4810
c	 0.8200	 0.5090
d	 0.7360	 0.3770
e	 0.6550	 0.3290
f	 0.8370	 0.4840
g	 0.8250	 0.4840
h	 0.8320	 0.5150



Continued on next page...

Continued from previous page...

Chain	Atom inclusion	Q-score
i	 0.7380	 0.3780
j	 0.6590	 0.3350