



wwPDB EM Validation Summary Report ⓘ

Mar 5, 2026 – 10:19 AM UTC

PDB ID : 9ER2 / pdb_00009er2
EMDB ID : EMD-19909
Title : PolIII-TCR-STK19 structure.
Authors : Kokic, G.
Deposited on : 2024-03-22
Resolution : 3.30 Å (reported)

This is a wwPDB EM Validation Summary Report for a publicly released PDB entry.

We welcome your comments at validation@mail.wwpdb.org

A user guide is available at

<https://www.wwpdb.org/validation/2017/EMValidationReportHelp>

with specific help available everywhere you see the ⓘ symbol.

The types of validation reports are described at

<http://www.wwpdb.org/validation/2017/FAQs#types>.

The following versions of software and data (see [references ⓘ](#)) were used in the production of this report:

EMDB validation analysis : 0.0.1.dev132
Mogul : 2022.3.0, CSD as543be (2022)
MolProbity : 4-5-2 with Phenix2.0
Buster-report : wwPDB partial adaption of 1.1.7 (2018)
Percentile statistics : 20250101.v01 (using entries in the PDB archive January 1st 2025)
EM percentile statistics : 202505.v01 (Using data in the EMDB archive up until May 2025)
MapQ : 1.9.13
Ideal geometry (proteins) : Engh & Huber (2001)
Ideal geometry (DNA, RNA) : Parkinson et al. (1996)
Validation Pipeline (wwPDB-VP) : 2.49

1 Overall quality at a glance i

The following experimental techniques were used to determine the structure:
ELECTRON MICROSCOPY

The reported resolution of this entry is 3.30 Å.

Percentile scores (ranging between 0-100) for global validation metrics of the entry are shown in the following graphic. The table shows the number of entries on which the scores are based.

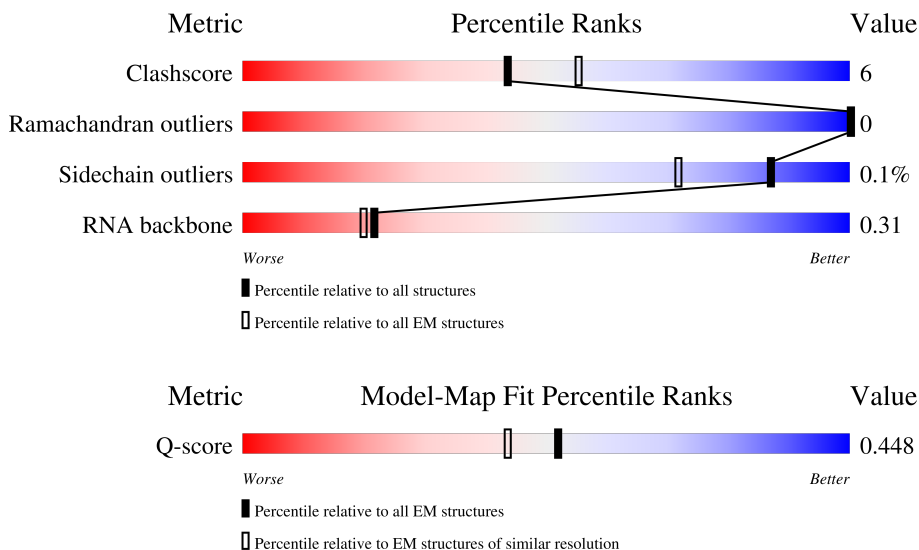













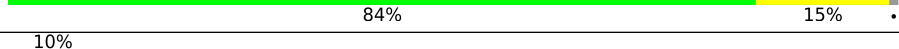
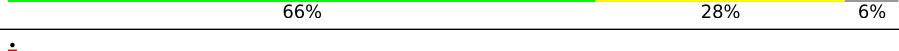
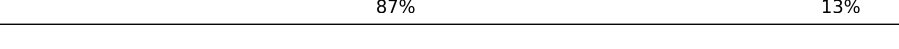
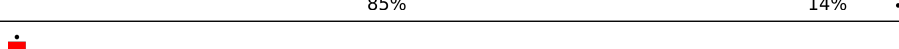
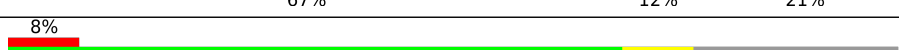

Metric	Whole archive (#Entries)	EM structures (#Entries)	Similar EM resolution (#Entries, resolution range(Å))
Clashscore	229148	23984	-
Ramachandran outliers	224038	23583	-
Sidechain outliers	223484	23102	-
RNA backbone	8273	3508	-
Q-score	-	25397	15087 (2.80 - 3.80)

The table below summarises the geometric issues observed across the polymeric chains and their fit to the map. The red, orange, yellow and green segments of the bar indicate the fraction of residues that contain outliers for ≥ 3 , 2, 1 and 0 types of geometric quality criteria respectively. A grey segment represents the fraction of residues that are not modelled. The numeric value for each fraction is indicated below the corresponding segment, with a dot representing fractions $\leq 5\%$. The upper red bar (where present) indicates the fraction of residues that have poor fit to the EM map (all-atom inclusion $< 40\%$). The numeric value is given above the bar.

Mol	Chain	Length	Quality of chain
1	P	14	
2	Q	258	
3	A	1984	

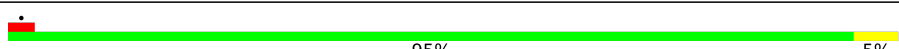
Continued on next page...

Continued from previous page...

Mol	Chain	Length	Quality of chain
4	B	1167	 81% 15%
5	C	275	 83% 12% 5%
6	D	142	 82% 73% 18% 10%
7	E	210	 83% 16%
8	F	127	 51% 13% 35%
9	G	172	 65% 77% 22%
10	H	150	 84% 15%
11	I	125	 10% 66% 28% 6%
12	J	67	 87% 13%
13	K	117	 85% 14%
14	L	58	 67% 12% 21%
15	N	52	 8% 69% 8% 23%
16	T	52	 90% 10%
17	M	709	 16% 5% 79%
17	c	709	 10% 14% 85%
18	O	64	 95% 5%
19	b	1493	 29% 6% 65%
20	a	396	 76% 16% 8%
21	d	1140	 58% 10% 31%

2 Entry composition [i](#)

There are 25 unique types of molecules in this entry. The entry contains 100218 atoms, of which 49569 are hydrogens and 0 are deuteriums.

In the tables below, the AltConf column contains the number of residues with at least one atom in alternate conformation and the Trace column contains the number of residues modelled with at most 2 atoms.

- Molecule 1 is a RNA chain called RNA (5'-R(P*CP*AP*AP*AP*AP*UP*CP*GP*AP*GP*AP*GP*GP*A)-3').

Mol	Chain	Residues	Atoms						AltConf	Trace
			Total	C	H	N	O	P		
1	P	14	458	137	152	63	92	14	0	0

- Molecule 2 is a protein called Isoform 1 of Inactive serine/threonine-protein kinase 19.

Mol	Chain	Residues	Atoms					AltConf	Trace	
			Total	C	H	N	O			S
2	Q	224	3534	1115	1782	312	317	8	0	0

- Molecule 3 is a protein called DNA-directed RNA polymerase subunit.

Mol	Chain	Residues	Atoms						AltConf	Trace
			Total	C	H	N	O	S		
3	A	1410	22478	7028	11308	2000	2071	71	0	0

- Molecule 4 is a protein called DNA-directed RNA polymerase subunit beta.

Mol	Chain	Residues	Atoms						AltConf	Trace
			Total	C	H	N	O	S		
4	B	1130	18132	5725	9084	1591	1668	64	0	0

- Molecule 5 is a protein called DNA-directed RNA polymerase II subunit RPB3.

Mol	Chain	Residues	Atoms						AltConf	Trace
			Total	C	H	N	O	S		
5	C	260	4120	1309	2031	359	415	6	0	0

- Molecule 6 is a protein called RNA polymerase II subunit D.

Mol	Chain	Residues	Atoms						AltConf	Trace
			Total	C	H	N	O	S		
6	D	128	1985	636	972	172	201	4	0	0

- Molecule 7 is a protein called DNA-directed RNA polymerase II subunit E.

Mol	Chain	Residues	Atoms					AltConf	Trace	
			Total	C	H	N	O			S
7	E	209	3457	1089	1737	300	323	8	0	0

- Molecule 8 is a protein called DNA-directed RNA polymerases I, II, and III subunit RPABC2.

Mol	Chain	Residues	Atoms					AltConf	Trace	
			Total	C	H	N	O			S
8	F	82	1341	418	684	113	121	5	0	0

- Molecule 9 is a protein called DNA-directed RNA polymerase subunit.

Mol	Chain	Residues	Atoms					AltConf	Trace	
			Total	C	H	N	O			S
9	G	171	2667	867	1333	216	243	8	0	0

- Molecule 10 is a protein called DNA-directed RNA polymerases I, II, and III subunit RPABC3.

Mol	Chain	Residues	Atoms					AltConf	Trace	
			Total	C	H	N	O			S
10	H	148	2333	750	1147	194	237	5	0	0

- Molecule 11 is a protein called DNA-directed RNA polymerase II subunit RPB9.

Mol	Chain	Residues	Atoms					AltConf	Trace	
			Total	C	H	N	O			S
11	I	117	1828	587	879	169	182	11	0	0

- Molecule 12 is a protein called DNA-directed RNA polymerases I, II, and III subunit RPABC5.

Mol	Chain	Residues	Atoms					AltConf	Trace	
			Total	C	H	N	O			S
12	J	67	1086	345	553	90	92	6	0	0

- Molecule 13 is a protein called DNA-directed RNA polymerase II subunit RPB11-a.

Mol	Chain	Residues	Atoms					AltConf	Trace	
			Total	C	H	N	O			S
13	K	115	1862	593	942	152	173	2	0	0

- Molecule 14 is a protein called RNA polymerase II subunit K.

Mol	Chain	Residues	Atoms					AltConf	Trace	
			Total	C	H	N	O			S
14	L	46	781	241	393	75	66	6	0	0

- Molecule 15 is a DNA chain called NTS.

Mol	Chain	Residues	Atoms					AltConf	Trace	
			Total	C	H	N	O			P
15	N	40	1278	393	449	162	234	40	0	0

- Molecule 16 is a DNA chain called TS.

Mol	Chain	Residues	Atoms					AltConf	Trace	
			Total	C	H	N	O			P
16	T	52	1544	476	553	160	303	52	0	0

- Molecule 17 is a protein called UV-stimulated scaffold protein A.

Mol	Chain	Residues	Atoms					AltConf	Trace	
			Total	C	H	N	O			S
17	c	108	1365	431	634	164	131	5	0	0
17	M	148	2449	771	1234	217	223	4	0	0

- Molecule 18 is a protein called Transcription elongation factor 1 homolog.

Mol	Chain	Residues	Atoms					AltConf	Trace	
			Total	C	H	N	O			S
18	O	64	968	312	463	81	105	7	0	0

- Molecule 19 is a protein called DNA excision repair protein ERCC-6.

Mol	Chain	Residues	Atoms					AltConf	Trace	
			Total	C	H	N	O			S
19	b	520	8558	2746	4299	746	746	21	0	0

- Molecule 20 is a protein called DNA excision repair protein ERCC-8.

Mol	Chain	Residues	Atoms					AltConf	Trace	
			Total	C	H	N	O			S
20	a	365	5618	1775	2769	507	548	19	0	0

- Molecule 21 is a protein called DNA damage-binding protein 1.

Mol	Chain	Residues	Atoms					AltConf	Trace	
			Total	C	H	N	O			S
21	d	781	12320	3916	6159	1038	1173	34	0	0

- Molecule 22 is ZINC ION (CCD ID: ZN) (formula: Zn).

Mol	Chain	Residues	Atoms		AltConf
22	A	2	Total	Zn	0
			2	2	
22	B	1	Total	Zn	0
			1	1	
22	C	1	Total	Zn	0
			1	1	
22	I	2	Total	Zn	0
			2	2	
22	J	1	Total	Zn	0
			1	1	
22	L	1	Total	Zn	0
			1	1	
22	c	2	Total	Zn	0
			2	2	
22	O	1	Total	Zn	0
			1	1	

- Molecule 23 is MAGNESIUM ION (CCD ID: MG) (formula: Mg).

Mol	Chain	Residues	Atoms		AltConf
23	A	1	Total	Mg	0
			1	1	
23	b	1	Total	Mg	0
			1	1	

- Molecule 24 is ADENOSINE-5'-DIPHOSPHATE (CCD ID: ADP) (formula: C₁₀H₁₅N₅O₁₀P₂).

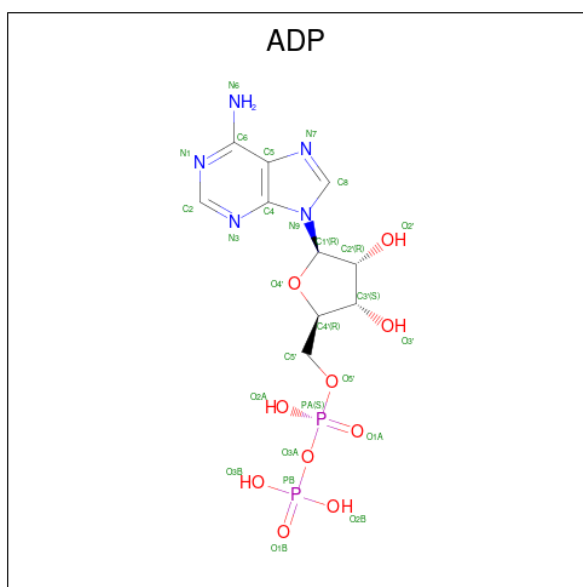

Mol	Chain	Residues	Atoms					AltConf	
			Total	C	H	N	O		P
24	b	1	39	10	12	5	10	2	0

- Molecule 25 is BERYLLIUM TRIFLUORIDE ION (CCD ID: BEF) (formula: BeF₃).

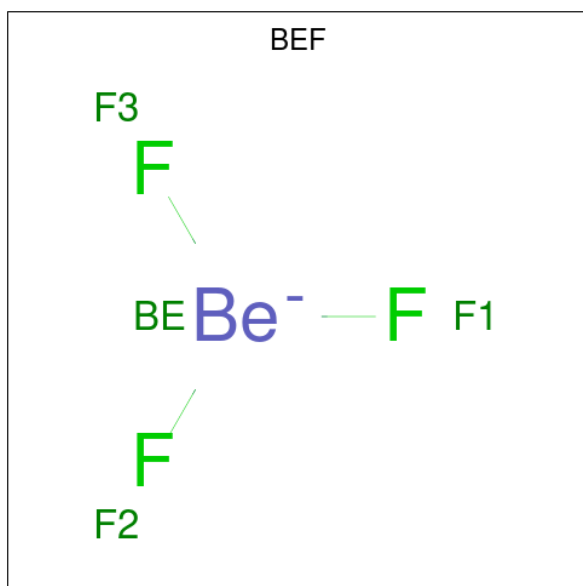

Mol	Chain	Residues	Atoms			AltConf
			Total	Be	F	
25	b	1	4	1	3	0

3 Residue-property plots [i](#)

These plots are drawn for all protein, RNA, DNA and oligosaccharide chains in the entry. The first graphic for a chain summarises the proportions of the various outlier classes displayed in the second graphic. The second graphic shows the sequence view annotated by issues in geometry and atom inclusion in map density. Residues are color-coded according to the number of geometric quality criteria for which they contain at least one outlier: green = 0, yellow = 1, orange = 2 and red = 3 or more. A red diamond above a residue indicates a poor fit to the EM map for this residue (all-atom inclusion < 40%). Stretches of 2 or more consecutive residues without any outlier are shown as a green connector. Residues present in the sample, but not in the model, are shown in grey.

- Molecule 1: RNA (5'-R(P*CP*AP*AP*AP*AP*UP*CP*GP*AP*GP*AP*GP*GP*A)-3')

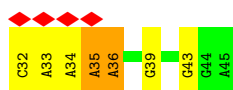

- Molecule 2: Isoform 1 of Inactive serine/threonine-protein kinase 19

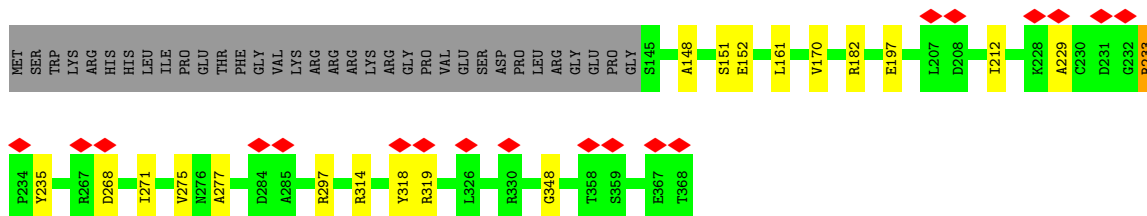
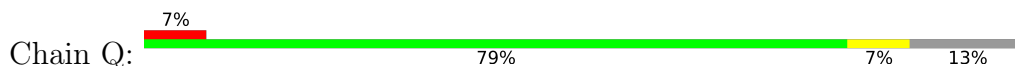

- Molecule 3: DNA-directed RNA polymerase subunit

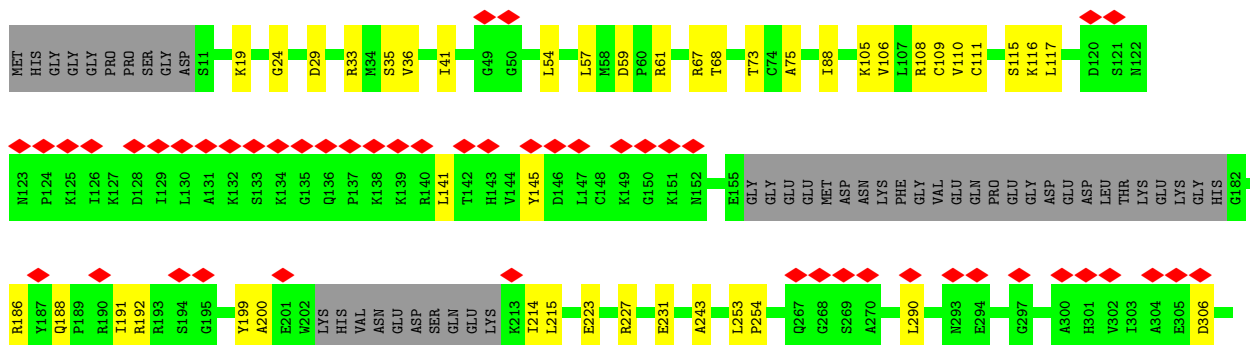

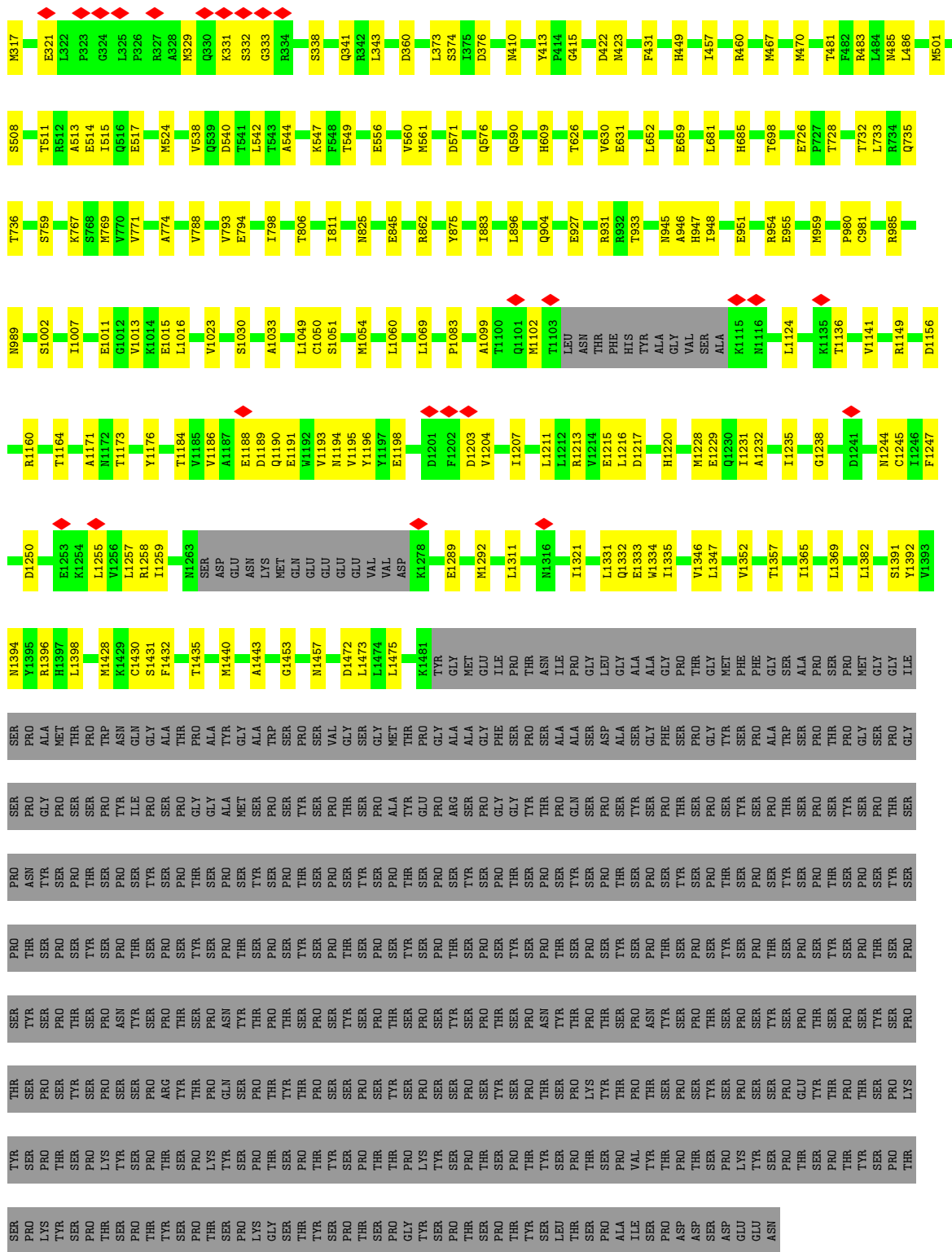

● Molecule 4: DNA-directed RNA polymerase subunit beta

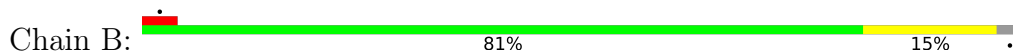

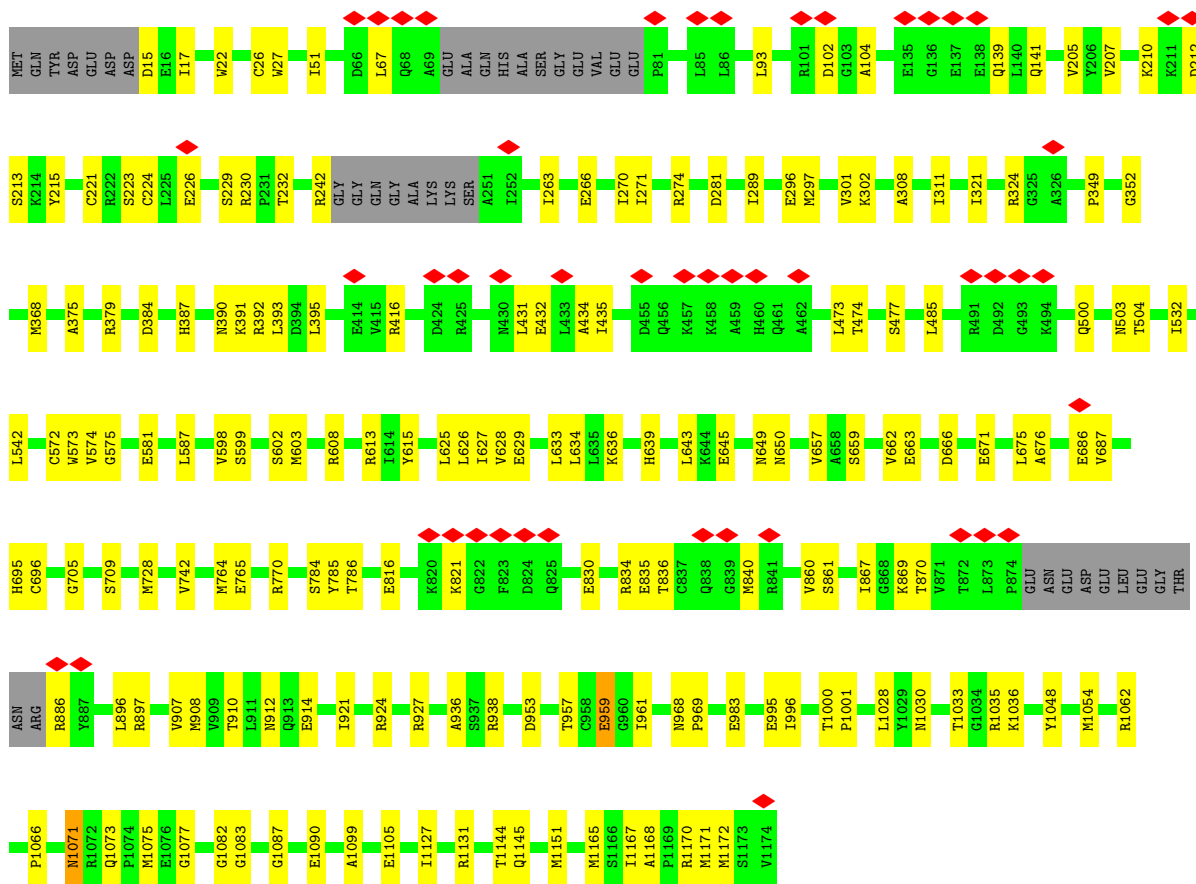

• Molecule 5: DNA-directed RNA polymerase II subunit RPB3

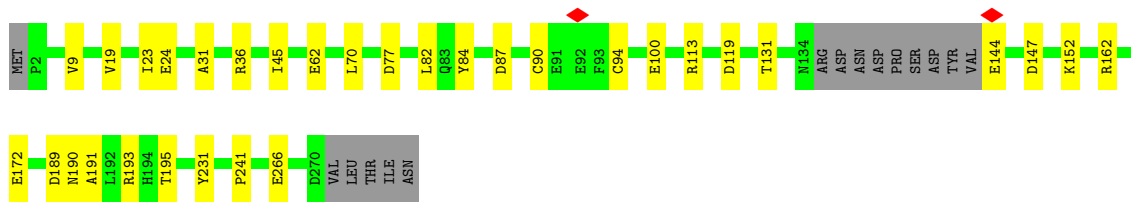
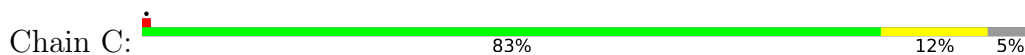

• Molecule 6: RNA polymerase II subunit D

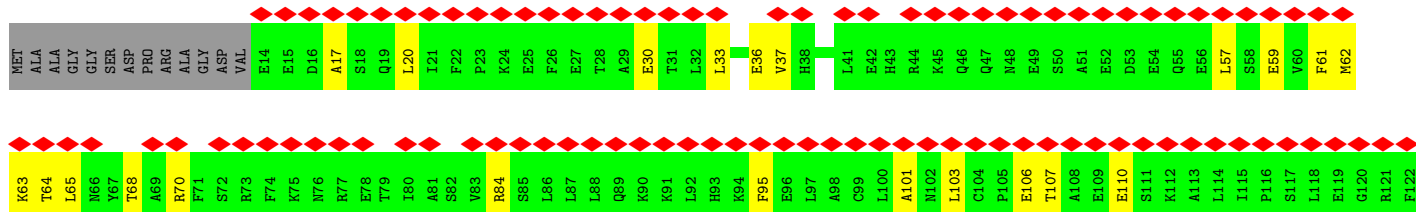
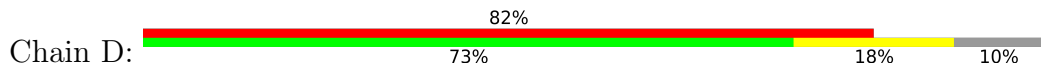



• Molecule 7: DNA-directed RNA polymerase II subunit E

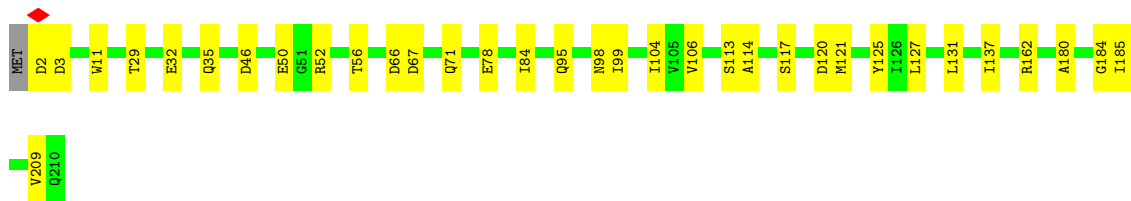
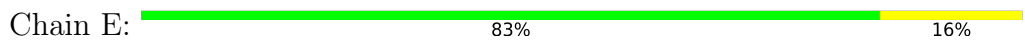

• Molecule 8: DNA-directed RNA polymerases I, II, and III subunit RPABC2

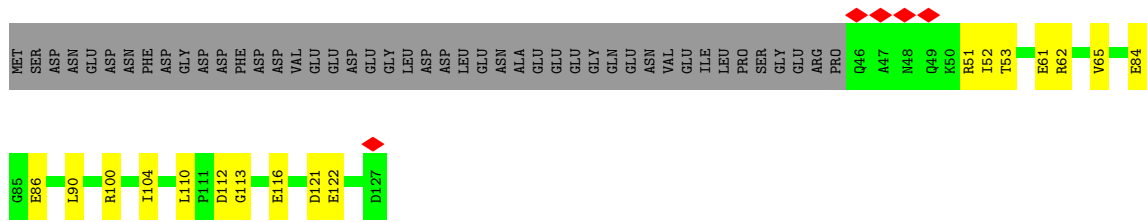

• Molecule 9: DNA-directed RNA polymerase subunit

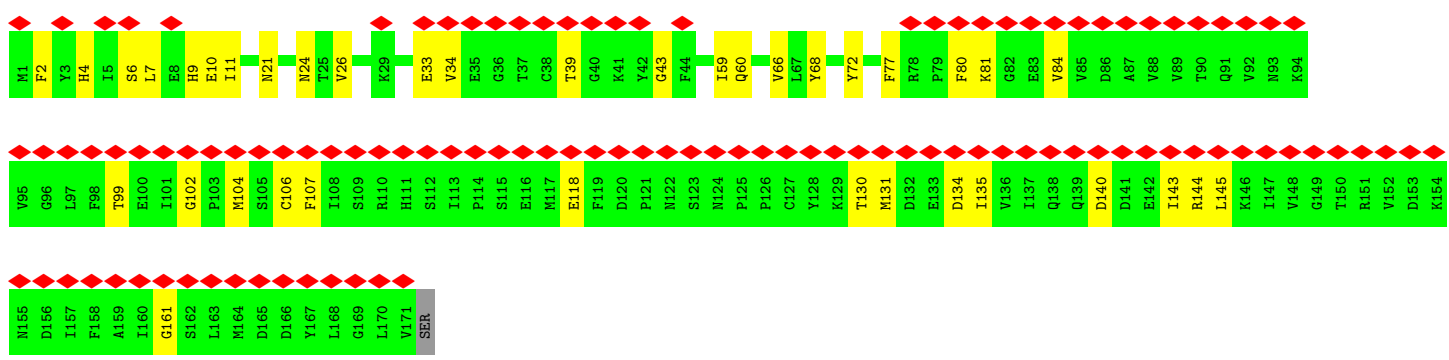
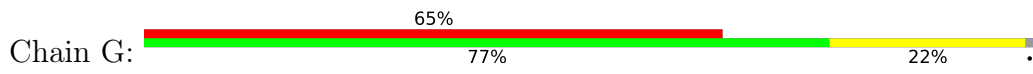

• Molecule 10: DNA-directed RNA polymerases I, II, and III subunit RPABC3

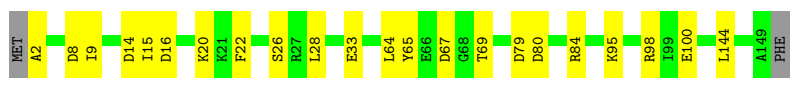
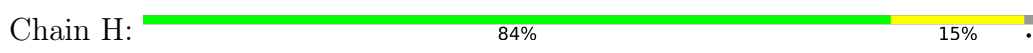

• Molecule 11: DNA-directed RNA polymerase II subunit RPB9

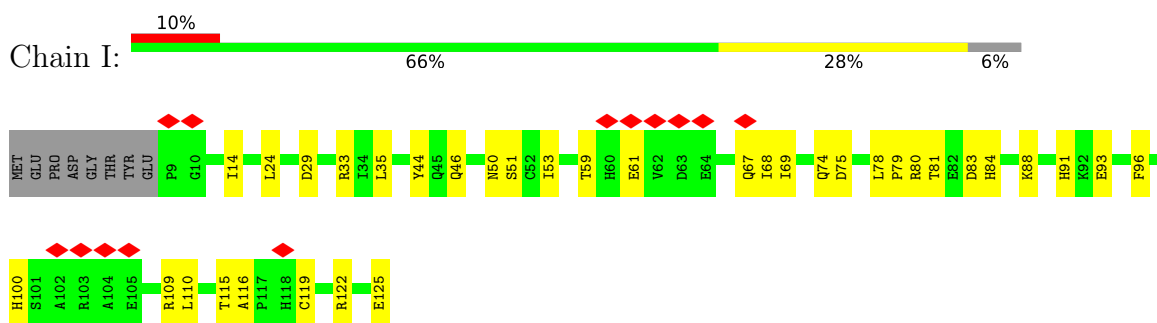

- Molecule 12: DNA-directed RNA polymerases I, II, and III subunit RPABC5

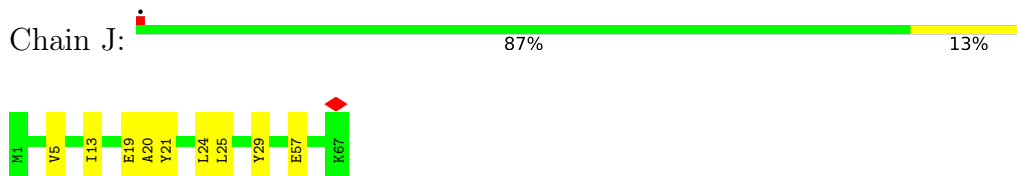

- Molecule 13: DNA-directed RNA polymerase II subunit RPB11-a

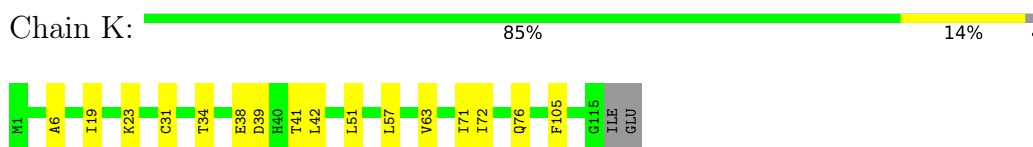

- Molecule 14: RNA polymerase II subunit K

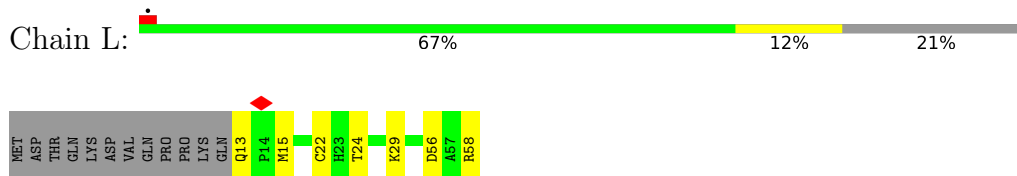

- Molecule 15: NTS

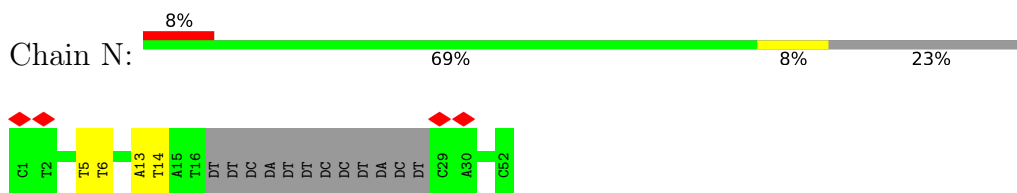

- Molecule 16: TS

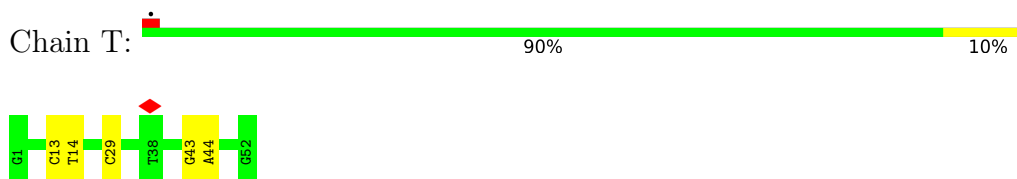

- Molecule 17: UV-stimulated scaffold protein A



4 Experimental information

Property	Value	Source
EM reconstruction method	SINGLE PARTICLE	Depositor
Imposed symmetry	POINT, Not provided	
Number of particles used	113958	Depositor
Resolution determination method	FSC 0.143 CUT-OFF	Depositor
CTF correction method	PHASE FLIPPING AND AMPLITUDE CORRECTION	Depositor
Microscope	TFS GLACIOS	Depositor
Voltage (kV)	200	Depositor
Electron dose ($e^-/\text{\AA}^2$)	39.6	Depositor
Minimum defocus (nm)	500	Depositor
Maximum defocus (nm)	2500	Depositor
Magnification	Not provided	
Image detector	FEI FALCON III (4k x 4k)	Depositor
Maximum map value	7.590	Depositor
Minimum map value	-3.746	Depositor
Average map value	0.014	Depositor
Map value standard deviation	0.140	Depositor
Recommended contour level	0.873	Depositor
Map size (\AA)	442.80002, 442.80002, 442.80002	wwPDB
Map dimensions	360, 360, 360	wwPDB
Map angles ($^\circ$)	90.0, 90.0, 90.0	wwPDB
Pixel spacing (\AA)	1.23, 1.23, 1.23	Depositor

5 Model quality i

5.1 Standard geometry i

Bond lengths and bond angles in the following residue types are not validated in this section: ZN, BEF, MG, ADP

The Z score for a bond length (or angle) is the number of standard deviations the observed value is removed from the expected value. A bond length (or angle) with $|Z| > 5$ is considered an outlier worth inspection. RMSZ is the root-mean-square of all Z scores of the bond lengths (or angles).

Mol	Chain	Bond lengths		Bond angles	
		RMSZ	# Z >5	RMSZ	# Z >5
1	P	0.64	0/344	1.13	6/535 (1.1%)
2	Q	0.31	0/1784	0.46	0/2416
3	A	0.58	1/11373 (0.0%)	0.59	0/15353
4	B	0.65	0/9229	0.58	1/12458 (0.0%)
5	C	0.66	0/2132	0.57	0/2896
6	D	0.18	0/1027	0.41	0/1384
7	E	0.50	0/1751	0.52	0/2366
8	F	0.58	0/667	0.55	0/901
9	G	0.27	0/1365	0.52	0/1853
10	H	0.55	0/1207	0.47	0/1628
11	I	0.54	1/972 (0.1%)	0.57	0/1316
12	J	0.68	0/542	0.58	0/730
13	K	0.57	0/939	0.52	0/1271
14	L	0.51	0/394	0.55	0/524
15	N	0.29	0/932	0.46	0/1435
16	T	0.51	0/1102	0.58	0/1682
17	M	0.23	0/1238	0.42	0/1664
17	c	0.22	0/741	0.49	0/976
18	O	0.42	0/515	0.43	0/700
19	b	0.25	0/4362	0.43	0/5890
20	a	0.53	0/2908	0.56	0/3939
21	d	0.29	0/6268	0.42	0/8466
All	All	0.51	2/51792 (0.0%)	0.54	7/70383 (0.0%)

Chiral center outliers are detected by calculating the chiral volume of a chiral center and verifying if the center is modelled as a planar moiety or with the opposite hand. A planarity outlier is detected by checking planarity of atoms in a peptide group, atoms in a mainchain group or atoms of a sidechain that are expected to be planar.

Mol	Chain	#Chirality outliers	#Planarity outliers
2	Q	0	1

Continued on next page...

Continued from previous page...

Mol	Chain	#Chirality outliers	#Planarity outliers
3	A	0	1
4	B	0	2
20	a	0	3
All	All	0	7

All (2) bond length outliers are listed below:

Mol	Chain	Res	Type	Atoms	Z	Observed(Å)	Ideal(Å)
11	I	24	LEU	C-N	-12.05	1.15	1.33
3	A	243	ALA	C-N	-8.07	1.22	1.33

The worst 5 of 7 bond angle outliers are listed below:

Mol	Chain	Res	Type	Atoms	Z	Observed(°)	Ideal(°)
1	P	36	A	OP1-P-OP2	-14.23	76.90	119.60
1	P	36	A	O5'-P-OP2	-13.72	66.83	108.00
1	P	35	A	OP2-P-O3'	9.97	137.90	108.00
1	P	36	A	O5'-P-OP1	7.09	129.28	108.00
1	P	35	A	OP1-P-O3'	-6.68	87.95	108.00

There are no chirality outliers.

5 of 7 planarity outliers are listed below:

Mol	Chain	Res	Type	Group
3	A	538	VAL	Peptide
4	B	1048	TYR	Sidechain
4	B	959	GLU	Peptide
2	Q	233	ARG	Peptide
20	a	173	LEU	Peptide

5.2 Too-close contacts

In the following table, the Non-H and H(model) columns list the number of non-hydrogen atoms and hydrogen atoms in the chain respectively. The H(added) column lists the number of hydrogen atoms added and optimized by MolProbity. The Clashes column lists the number of clashes within the asymmetric unit, whereas Symm-Clashes lists symmetry-related clashes.

Mol	Chain	Non-H	H(model)	H(added)	Clashes	Symm-Clashes
1	P	306	152	153	1	0
2	Q	1752	1782	1787	14	0

Continued on next page...

Continued from previous page...

Mol	Chain	Non-H	H(model)	H(added)	Clashes	Symm-Clashes
3	A	11170	11308	11311	164	0
4	B	9048	9084	9084	131	0
5	C	2089	2031	2031	21	0
6	D	1013	972	972	18	0
7	E	1720	1737	1737	22	0
8	F	657	684	684	14	0
9	G	1334	1333	1333	29	0
10	H	1186	1147	1147	14	0
11	I	949	879	878	22	0
12	J	533	553	553	8	0
13	K	920	942	942	11	0
14	L	388	393	393	4	0
15	N	829	449	450	3	0
16	T	991	553	553	4	0
17	M	1215	1234	1235	29	0
17	c	731	634	633	7	0
18	O	505	463	463	2	0
19	b	4259	4299	4302	67	0
20	a	2849	2769	2778	51	0
21	d	6161	6159	6159	75	0
22	A	2	0	0	0	0
22	B	1	0	0	0	0
22	C	1	0	0	0	0
22	I	2	0	0	0	0
22	J	1	0	0	0	0
22	L	1	0	0	0	0
22	O	1	0	0	0	0
22	c	2	0	0	0	0
23	A	1	0	0	0	0
23	b	1	0	0	0	0
24	b	27	12	11	2	0
25	b	4	0	0	1	0
All	All	50649	49569	49589	644	0

The all-atom clashscore is defined as the number of clashes found per 1000 atoms (including hydrogen atoms). The all-atom clashscore for this structure is 6.

The worst 5 of 644 close contacts within the same asymmetric unit are listed below, sorted by their clash magnitude.

Atom-1	Atom-2	Interatomic distance (Å)	Clash overlap (Å)
2:Q:318:TYR:OH	17:M:41:ARG:NH1	2.06	0.89

Continued on next page...

Continued from previous page...

Atom-1	Atom-2	Interatomic distance (Å)	Clash overlap (Å)
20:a:210:ARG:NH2	20:a:238:GLU:O	2.10	0.85
5:C:190:ASN:O	5:C:193:ARG:NH1	2.13	0.81
5:C:152:LYS:NZ	12:J:57:GLU:OE2	2.13	0.81
3:A:927:GLU:OE2	3:A:931:ARG:NH2	2.13	0.81

There are no symmetry-related clashes.

5.3 Torsion angles [i](#)

5.3.1 Protein backbone [i](#)

In the following table, the Percentiles column shows the percent Ramachandran outliers of the chain as a percentile score with respect to all PDB entries followed by that with respect to all EM entries.

The Analysed column shows the number of residues for which the backbone conformation was analysed, and the total number of residues.

Mol	Chain	Analysed	Favoured	Allowed	Outliers	Percentiles	
2	Q	222/258 (86%)	212 (96%)	10 (4%)	0	100	100
3	A	1400/1984 (71%)	1294 (92%)	106 (8%)	0	100	100
4	B	1122/1167 (96%)	1031 (92%)	91 (8%)	0	100	100
5	C	256/275 (93%)	238 (93%)	18 (7%)	0	100	100
6	D	126/142 (89%)	119 (94%)	7 (6%)	0	100	100
7	E	207/210 (99%)	193 (93%)	14 (7%)	0	100	100
8	F	80/127 (63%)	74 (92%)	6 (8%)	0	100	100
9	G	169/172 (98%)	158 (94%)	11 (6%)	0	100	100
10	H	146/150 (97%)	136 (93%)	10 (7%)	0	100	100
11	I	115/125 (92%)	105 (91%)	10 (9%)	0	100	100
12	J	65/67 (97%)	62 (95%)	3 (5%)	0	100	100
13	K	113/117 (97%)	109 (96%)	4 (4%)	0	100	100
14	L	44/58 (76%)	35 (80%)	9 (20%)	0	100	100
17	M	146/709 (21%)	142 (97%)	4 (3%)	0	100	100
17	c	104/709 (15%)	101 (97%)	3 (3%)	0	100	100
18	O	62/64 (97%)	62 (100%)	0	0	100	100

Continued on next page...

Continued from previous page...

Mol	Chain	Analysed	Favoured	Allowed	Outliers	Percentiles	
19	b	512/1493 (34%)	484 (94%)	28 (6%)	0	100	100
20	a	363/396 (92%)	316 (87%)	47 (13%)	0	100	100
21	d	765/1140 (67%)	722 (94%)	43 (6%)	0	100	100
All	All	6017/9363 (64%)	5593 (93%)	424 (7%)	0	100	100

There are no Ramachandran outliers to report.

5.3.2 Protein sidechains [i](#)

In the following table, the Percentiles column shows the percent sidechain outliers of the chain as a percentile score with respect to all PDB entries followed by that with respect to all EM entries.

The Analysed column shows the number of residues for which the sidechain conformation was analysed, and the total number of residues.

Mol	Chain	Analysed	Rotameric	Outliers	Percentiles	
2	Q	188/218 (86%)	188 (100%)	0	100	100
3	A	1242/1763 (70%)	1242 (100%)	0	100	100
4	B	992/1021 (97%)	991 (100%)	1 (0%)	88	90
5	C	237/252 (94%)	237 (100%)	0	100	100
6	D	108/126 (86%)	108 (100%)	0	100	100
7	E	191/192 (100%)	191 (100%)	0	100	100
8	F	71/111 (64%)	71 (100%)	0	100	100
9	G	147/153 (96%)	147 (100%)	0	100	100
10	H	129/131 (98%)	129 (100%)	0	100	100
11	I	105/112 (94%)	105 (100%)	0	100	100
12	J	56/56 (100%)	56 (100%)	0	100	100
13	K	104/106 (98%)	104 (100%)	0	100	100
14	L	43/55 (78%)	43 (100%)	0	100	100
17	M	132/608 (22%)	132 (100%)	0	100	100
17	c	60/608 (10%)	60 (100%)	0	100	100
18	O	59/59 (100%)	59 (100%)	0	100	100
19	b	466/1297 (36%)	466 (100%)	0	100	100
20	a	320/348 (92%)	319 (100%)	1 (0%)	86	86

Continued on next page...

Continued from previous page...

Mol	Chain	Analysed	Rotameric	Outliers	Percentiles	
21	d	685/999 (69%)	684 (100%)	1 (0%)	88	90
All	All	5335/8215 (65%)	5332 (100%)	3 (0%)	87	90

All (3) residues with a non-rotameric sidechain are listed below:

Mol	Chain	Res	Type
4	B	1071	ASN
20	a	212	LYS
21	d	796	GLN

Sometimes sidechains can be flipped to improve hydrogen bonding and reduce clashes. 5 of 46 such sidechains are listed below:

Mol	Chain	Res	Type
10	H	131	ASN
19	b	669	HIS
11	I	118	HIS
17	M	140	HIS
19	b	878	GLN

5.3.3 RNA [i](#)

Mol	Chain	Analysed	Backbone Outliers	Pucker Outliers
1	P	13/14 (92%)	6 (46%)	0

5 of 6 RNA backbone outliers are listed below:

Mol	Chain	Res	Type
1	P	33	A
1	P	34	A
1	P	35	A
1	P	36	A
1	P	39	G

There are no RNA pucker outliers to report.

5.4 Non-standard residues in protein, DNA, RNA chains [i](#)

There are no non-standard protein/DNA/RNA residues in this entry.

5.5 Carbohydrates [i](#)

There are no oligosaccharides in this entry.

5.6 Ligand geometry [i](#)

Of 15 ligands modelled in this entry, 13 are monoatomic - leaving 2 for Mogul analysis.

In the following table, the Counts columns list the number of bonds (or angles) for which Mogul statistics could be retrieved, the number of bonds (or angles) that are observed in the model and the number of bonds (or angles) that are defined in the Chemical Component Dictionary. The Link column lists molecule types, if any, to which the group is linked. The Z score for a bond length (or angle) is the number of standard deviations the observed value is removed from the expected value. A bond length (or angle) with $|Z| > 2$ is considered an outlier worth inspection. RMSZ is the root-mean-square of all Z scores of the bond lengths (or angles).

Mol	Type	Chain	Res	Link	Bond lengths			Bond angles		
					Counts	RMSZ	# Z > 2	Counts	RMSZ	# Z > 2
24	ADP	b	1501	23	28,29,29	3.68	10 (35%)	43,45,45	1.89	11 (25%)
25	BEF	b	1502	-	0,3,3	-	-	-		

In the following table, the Chirals column lists the number of chiral outliers, the number of chiral centers analysed, the number of these observed in the model and the number defined in the Chemical Component Dictionary. Similar counts are reported in the Torsion and Rings columns. '-' means no outliers of that kind were identified.

Mol	Type	Chain	Res	Link	Chirals	Torsions	Rings
24	ADP	b	1501	23	-	1/16/32/32	0/3/3/3

The worst 5 of 10 bond length outliers are listed below:

Mol	Chain	Res	Type	Atoms	Z	Observed(Å)	Ideal(Å)
24	b	1501	ADP	PA-O3A	10.95	1.71	1.59
24	b	1501	ADP	O4'-C1'	8.79	1.62	1.42
24	b	1501	ADP	C2'-C1'	-8.20	1.27	1.53
24	b	1501	ADP	O4'-C4'	-5.82	1.32	1.45
24	b	1501	ADP	C6-N6	4.85	1.46	1.34

The worst 5 of 11 bond angle outliers are listed below:

Mol	Chain	Res	Type	Atoms	Z	Observed(°)	Ideal(°)
24	b	1501	ADP	N3-C2-N1	-5.60	120.10	128.58
24	b	1501	ADP	C5-C4-N3	-4.86	120.02	126.72
24	b	1501	ADP	N9-C8-N7	-4.08	108.14	113.94

Continued on next page...

Continued from previous page...

Mol	Chain	Res	Type	Atoms	Z	Observed(°)	Ideal(°)
24	b	1501	ADP	N6-C6-N1	-3.65	110.24	118.38
24	b	1501	ADP	C2-N3-C4	3.36	120.04	111.83

There are no chirality outliers.

All (1) torsion outliers are listed below:

Mol	Chain	Res	Type	Atoms
24	b	1501	ADP	C5'-O5'-PA-O1A

There are no ring outliers.

2 monomers are involved in 3 short contacts:

Mol	Chain	Res	Type	Clashes	Symm-Clashes
24	b	1501	ADP	2	0
25	b	1502	BEF	1	0

The following is a two-dimensional graphical depiction of Mogul quality analysis of bond lengths, bond angles, torsion angles, and ring geometry for all instances of the Ligand of Interest. In addition, ligands with molecular weight > 250 and outliers as shown on the validation Tables will also be included. For torsion angles, if less than 5% of the Mogul distribution of torsion angles is within 10 degrees of the torsion angle in question, then that torsion angle is considered an outlier. Any bond that is central to one or more torsion angles identified as an outlier by Mogul will be highlighted in the graph. For rings, the root-mean-square deviation (RMSD) between the ring in question and similar rings identified by Mogul is calculated over all ring torsion angles. If the average RMSD is greater than 60 degrees and the minimal RMSD between the ring in question and any Mogul-identified rings is also greater than 60 degrees, then that ring is considered an outlier. The outliers are highlighted in purple. The color gray indicates Mogul did not find sufficient equivalents in the CSD to analyse the geometry.

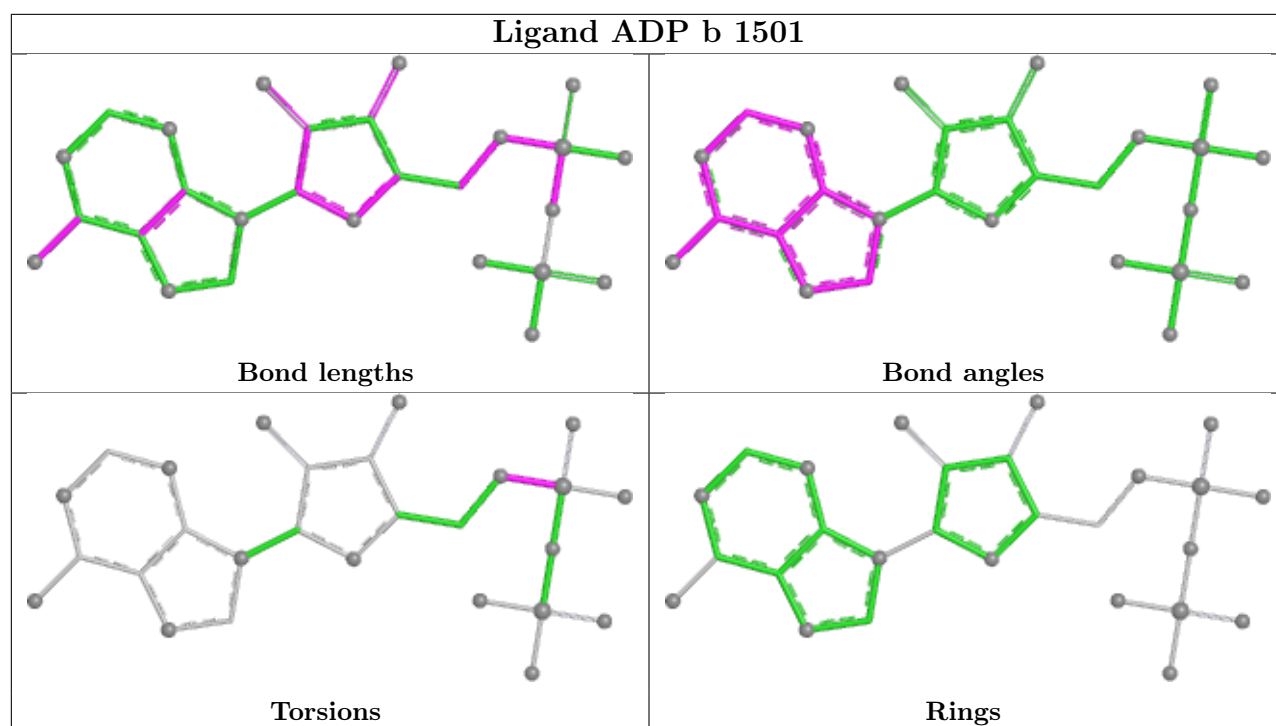

5.7 Other polymers [i](#)

There are no such residues in this entry.

5.8 Polymer linkage issues [i](#)

The following chains have linkage breaks:

Mol	Chain	Number of breaks
11	I	1

All chain breaks are listed below:

Model	Chain	Residue-1	Atom-1	Residue-2	Atom-2	Distance (Å)
1	I	24:LEU	C	25:TYR	N	1.15

6 Map visualisation [i](#)

This section contains visualisations of the EMDB entry EMD-19909. These allow visual inspection of the internal detail of the map and identification of artifacts.

Images derived from a raw map, generated by summing the deposited half-maps, are presented below the corresponding image components of the primary map to allow further visual inspection and comparison with those of the primary map.

6.1 Orthogonal projections [i](#)

6.1.1 Primary map

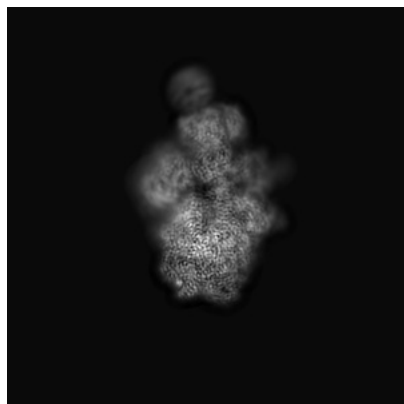

X

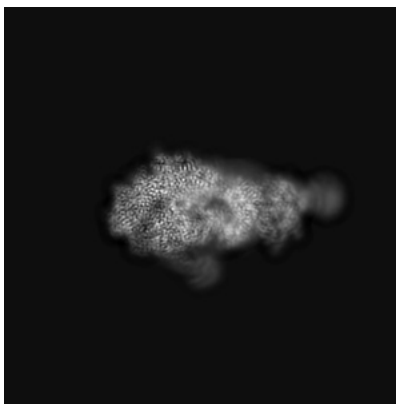

Y

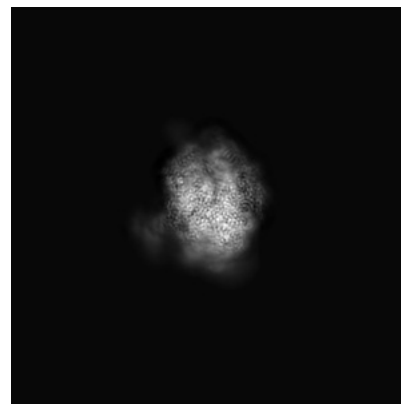

Z

6.1.2 Raw map

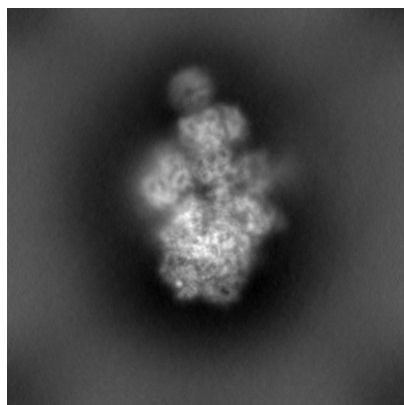

X

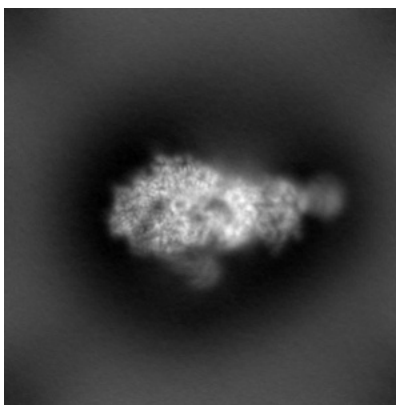

Y

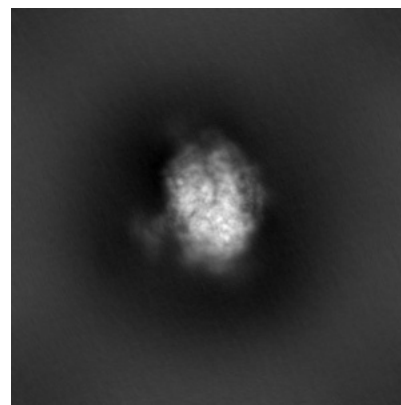

Z

The images above show the map projected in three orthogonal directions.

6.2 Central slices [i](#)

6.2.1 Primary map

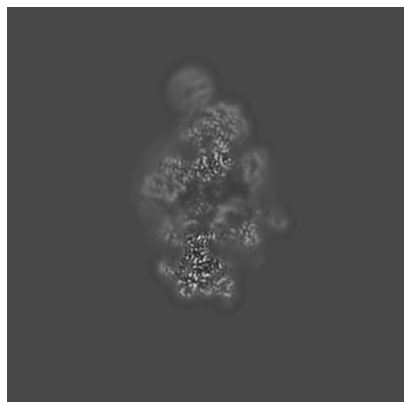

X Index: 180

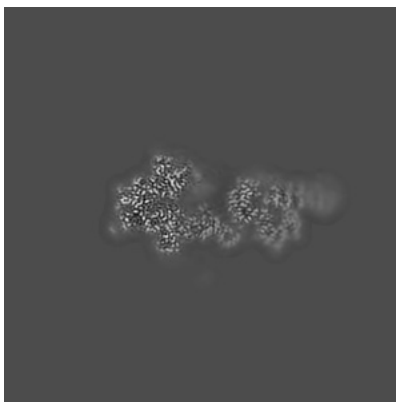

Y Index: 180

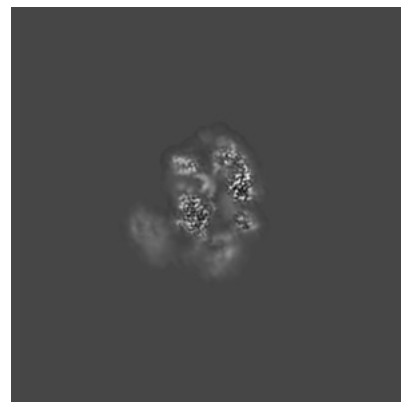

Z Index: 180

6.2.2 Raw map

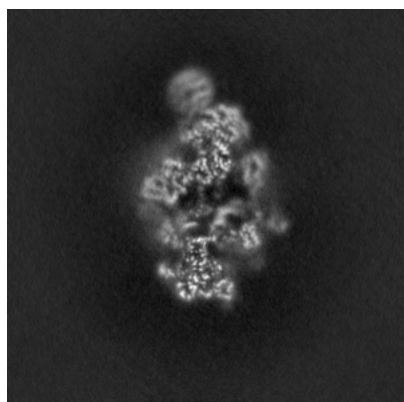

X Index: 180

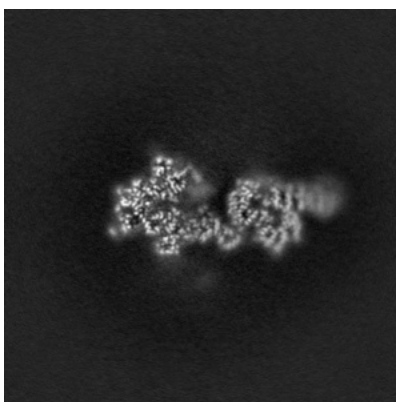

Y Index: 180

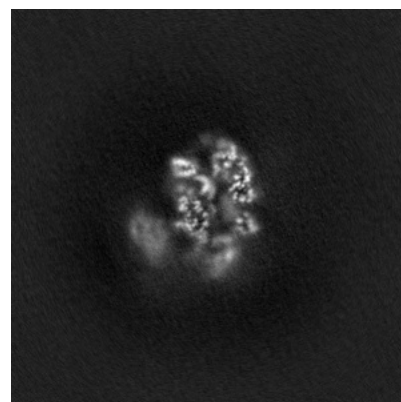

Z Index: 180

The images above show central slices of the map in three orthogonal directions.

6.3 Largest variance slices [i](#)

6.3.1 Primary map

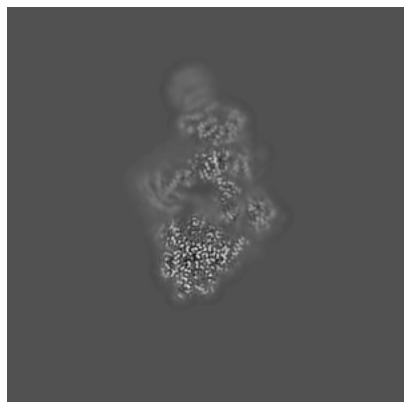

X Index: 194

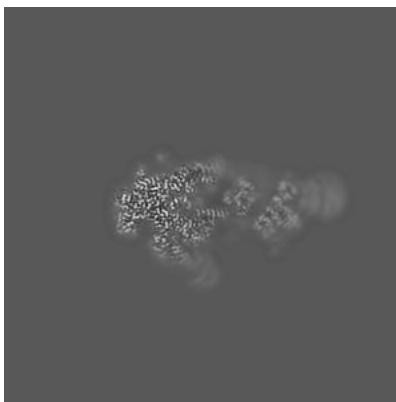

Y Index: 168

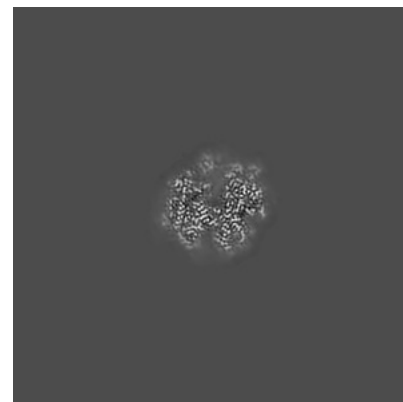

Z Index: 145

6.3.2 Raw map

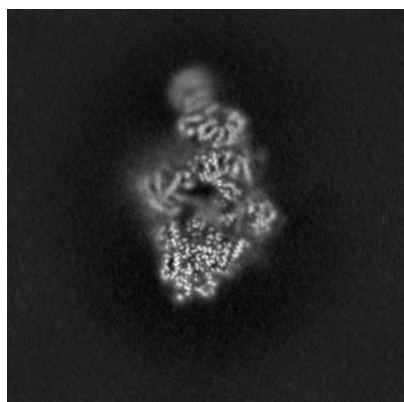

X Index: 194

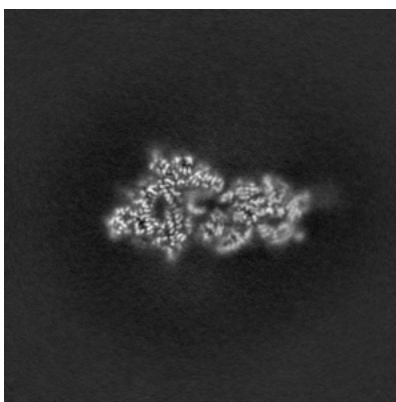

Y Index: 189

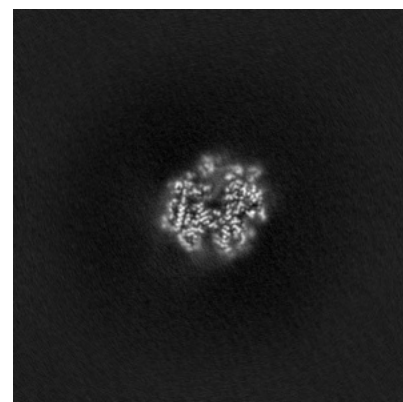

Z Index: 145

The images above show the largest variance slices of the map in three orthogonal directions.

6.4 Orthogonal standard-deviation projections (False-color) [i](#)

6.4.1 Primary map

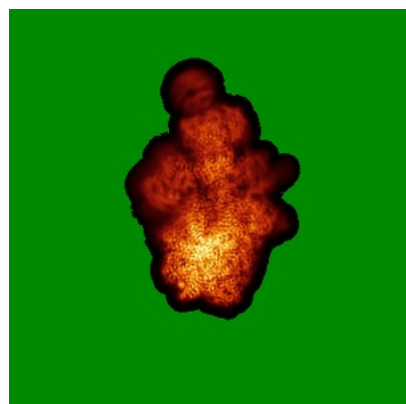

X

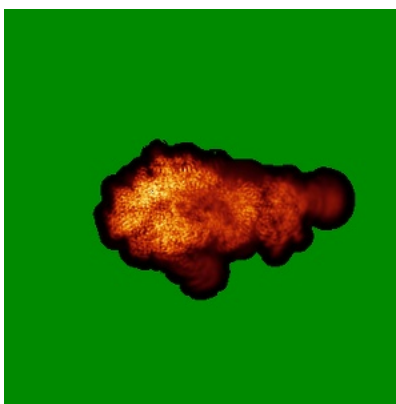

Y

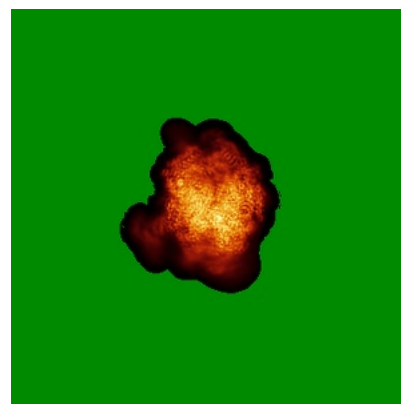

Z

6.4.2 Raw map

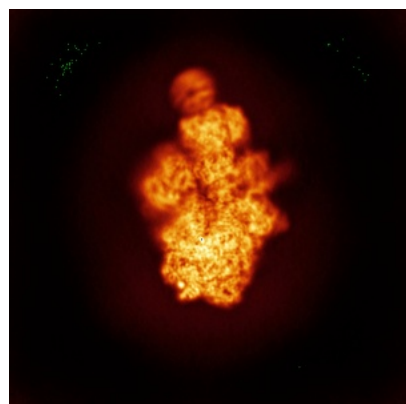

X

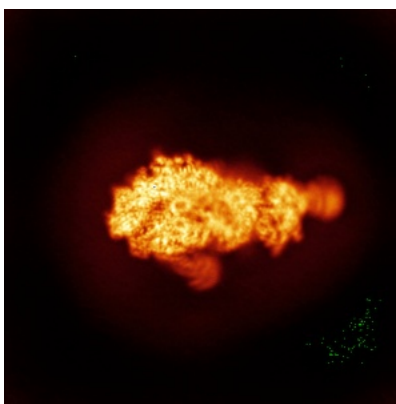

Y

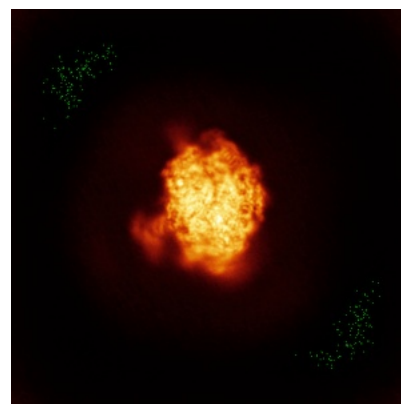

Z

The images above show the map standard deviation projections with false color in three orthogonal directions. Minimum values are shown in green, max in blue, and dark to light orange shades represent small to large values respectively.

6.5 Orthogonal surface views [i](#)

6.5.1 Primary map

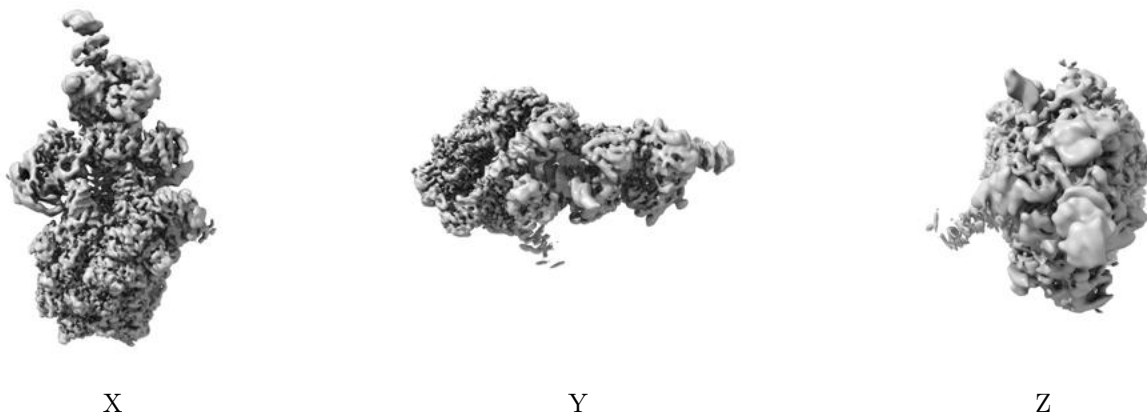

The images above show the 3D surface view of the map at the recommended contour level 0.873. These images, in conjunction with the slice images, may facilitate assessment of whether an appropriate contour level has been provided.

6.5.2 Raw map

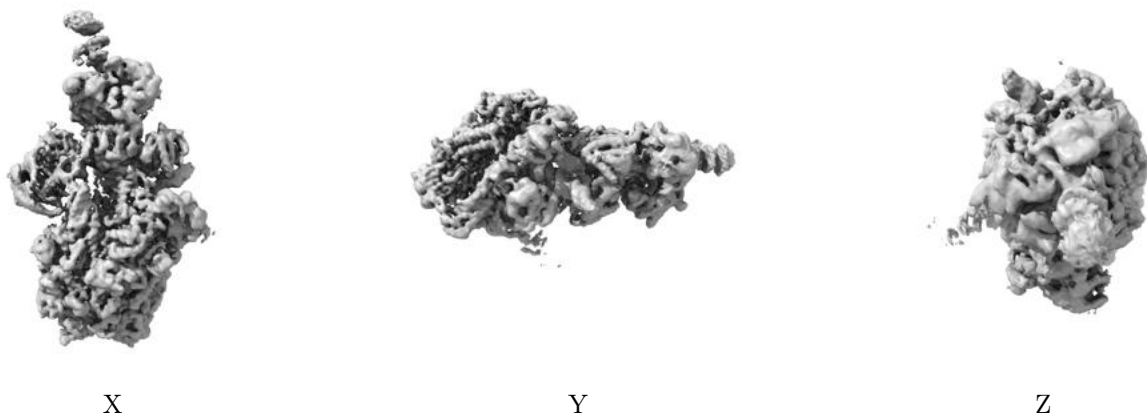

These images show the 3D surface of the raw map. The raw map's contour level was selected so that its surface encloses the same volume as the primary map does at its recommended contour level.

6.6 Mask visualisation [i](#)

This section was not generated. No masks/segmentation were deposited.

7 Map analysis [i](#)

This section contains the results of statistical analysis of the map.

7.1 Map-value distribution [i](#)

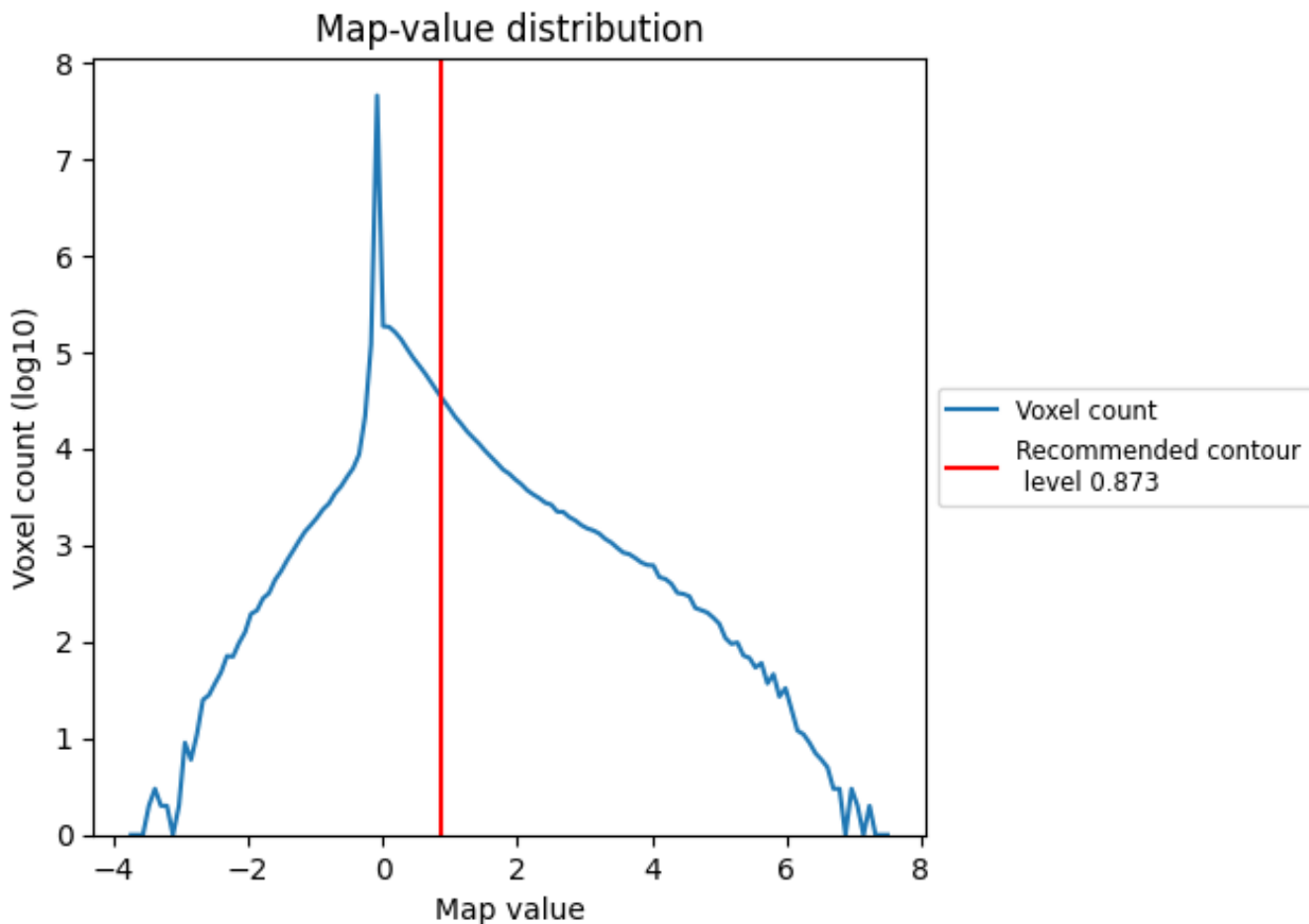

The map-value distribution is plotted in 128 intervals along the x-axis. The y-axis is logarithmic. A spike in this graph at zero usually indicates that the volume has been masked.

7.2 Volume estimate [i](#)

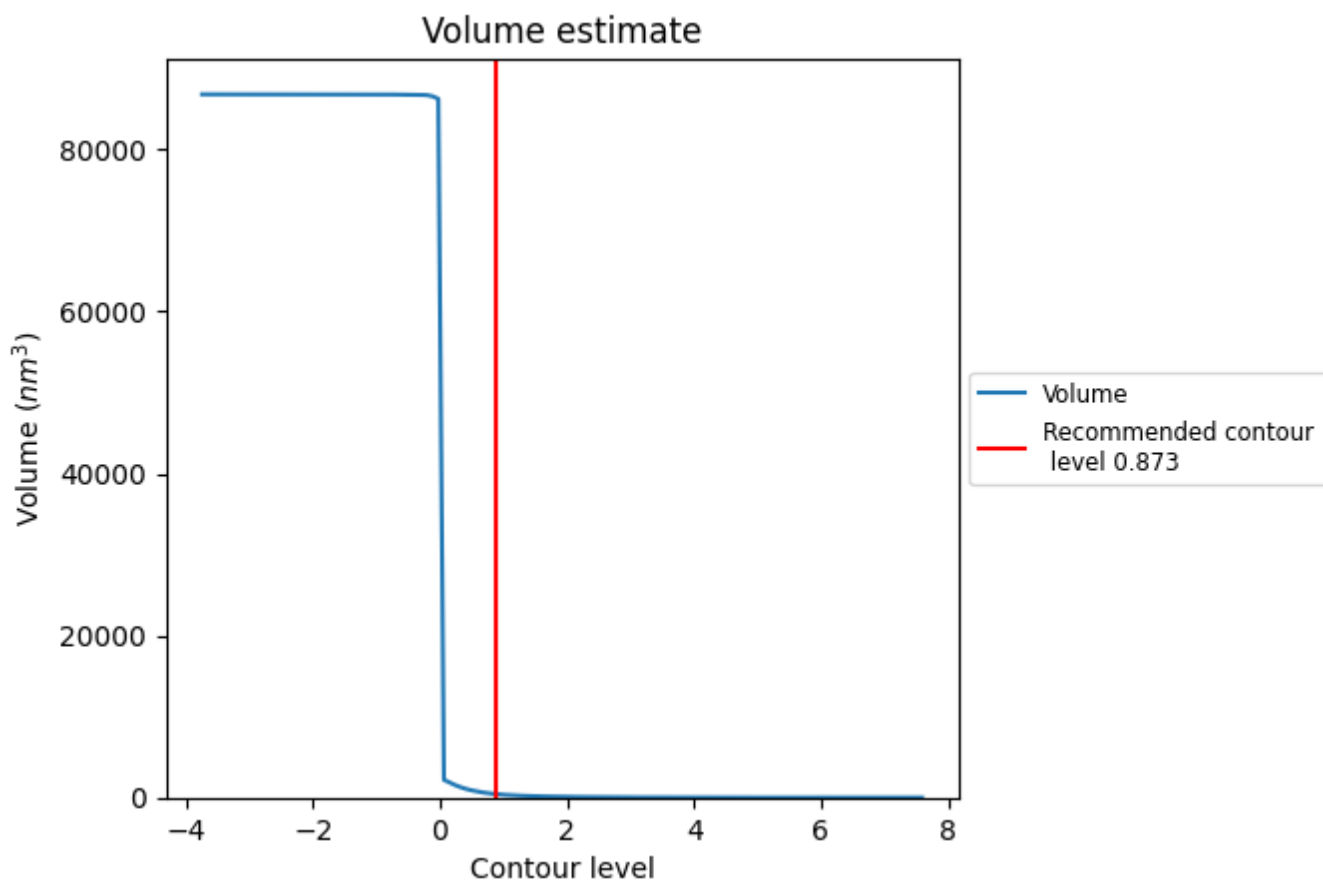

The volume at the recommended contour level is 432 nm³; this corresponds to an approximate mass of 390 kDa.

The volume estimate graph shows how the enclosed volume varies with the contour level. The recommended contour level is shown as a vertical line and the intersection between the line and the curve gives the volume of the enclosed surface at the given level.

7.3 Rotationally averaged power spectrum i

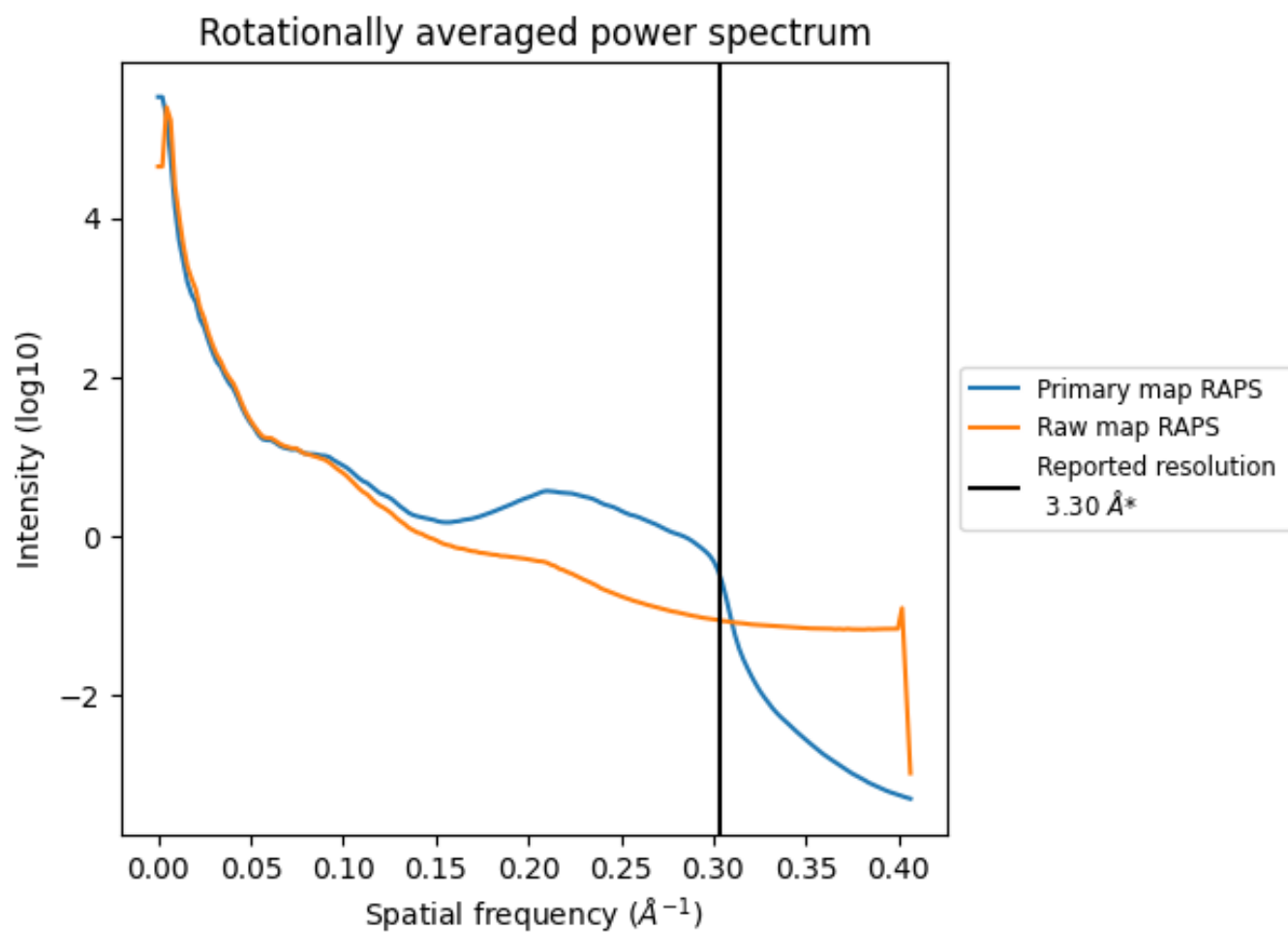

*Reported resolution corresponds to spatial frequency of 0.303 Å⁻¹

8 Fourier-Shell correlation [i](#)

Fourier-Shell Correlation (FSC) is the most commonly used method to estimate the resolution of single-particle and subtomogram-averaged maps. The shape of the curve depends on the imposed symmetry, mask and whether or not the two 3D reconstructions used were processed from a common reference. The reported resolution is shown as a black line. A curve is displayed for the half-bit criterion in addition to lines showing the 0.143 gold standard cut-off and 0.5 cut-off.

8.1 FSC [i](#)

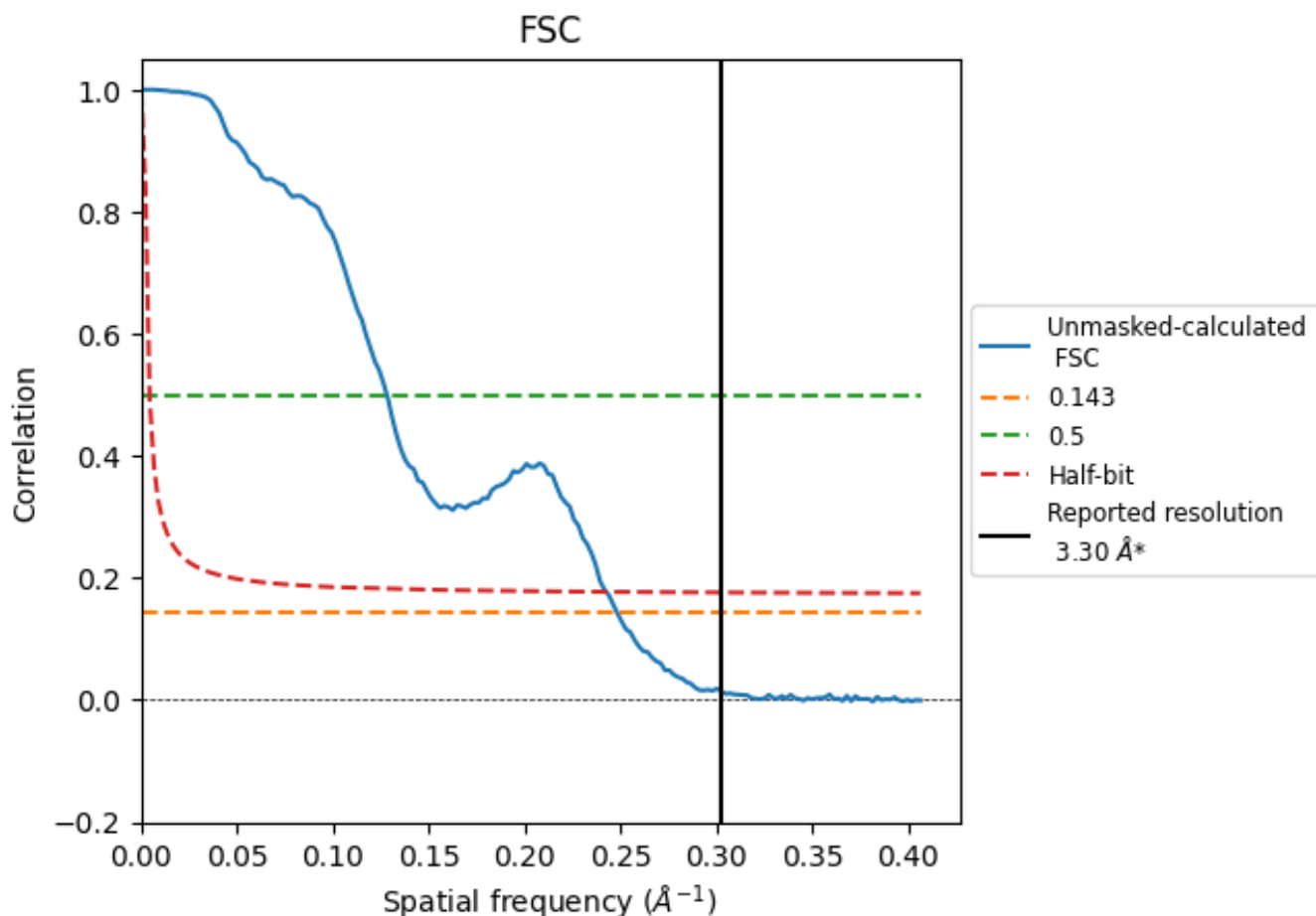

*Reported resolution corresponds to spatial frequency of 0.303 Å⁻¹

8.2 Resolution estimates [i](#)

Resolution estimate (Å)	Estimation criterion (FSC cut-off)		
	0.143	0.5	Half-bit
Reported by author	3.30	-	-
Author-provided FSC curve	-	-	-
Unmasked-calculated*	4.03	7.80	4.12

*Resolution estimate based on FSC curve calculated by comparison of deposited half-maps. The value from deposited half-maps intersecting FSC 0.143 CUT-OFF 4.03 differs from the reported value 3.3 by more than 10 %

9 Map-model fit [i](#)

This section contains information regarding the fit between EMDB map EMD-19909 and PDB model 9ER2. Per-residue inclusion information can be found in section 3 on page 9.

9.1 Map-model overlay [i](#)

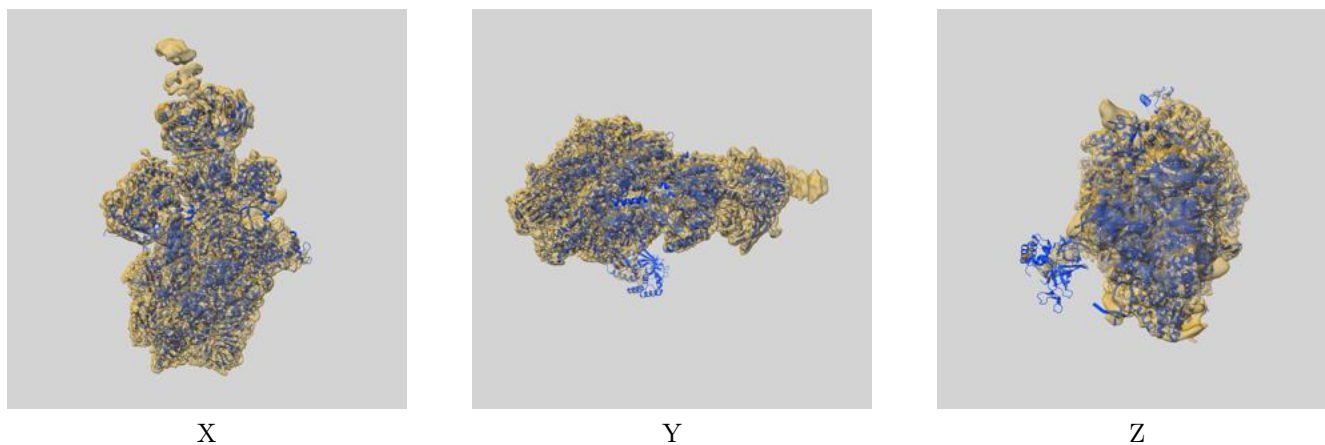

The images above show the 3D surface view of the map at the recommended contour level 0.873 at 50% transparency in yellow overlaid with a ribbon representation of the model coloured in blue. These images allow for the visual assessment of the quality of fit between the atomic model and the map.

9.2 Q-score mapped to coordinate model [i](#)

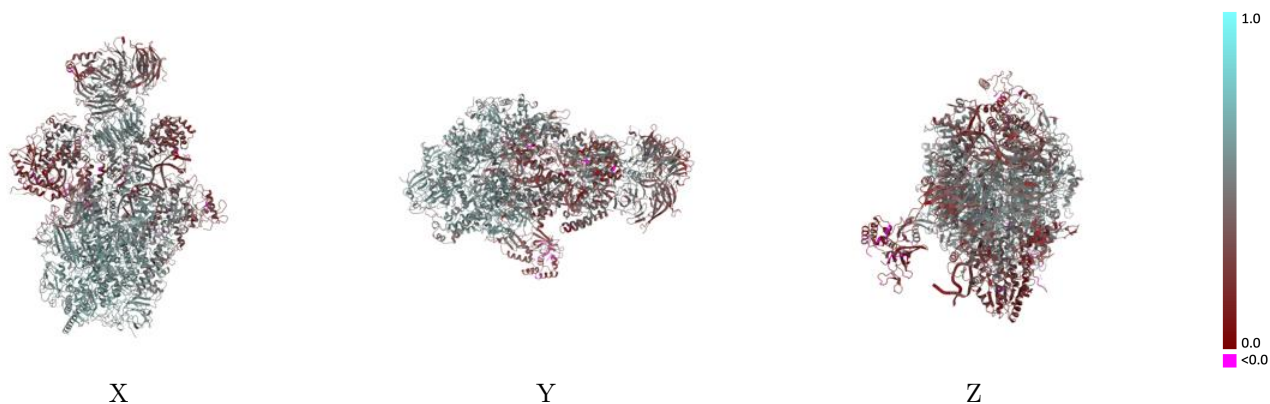

The images above show the model with each residue coloured according to its Q-score. This shows their resolvability in the map with higher Q-score values reflecting better resolvability. Please note: Q-score is calculating the resolvability of atoms, and thus high values are only expected at resolutions at which atoms can be resolved. Low Q-score values may therefore be expected for many entries.

9.3 Atom inclusion mapped to coordinate model [i](#)

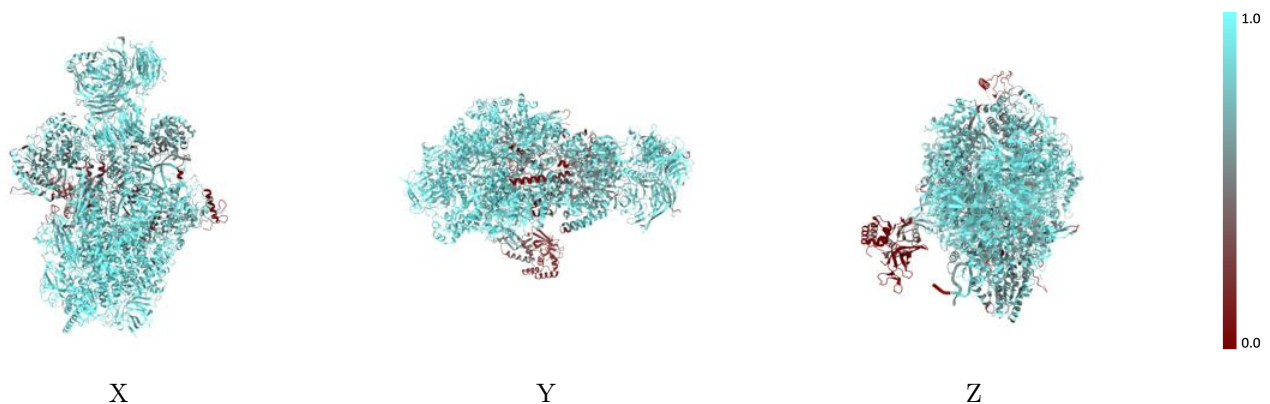

The images above show the model with each residue coloured according to its atom inclusion. This shows to what extent they are inside the map at the recommended contour level (0.873).



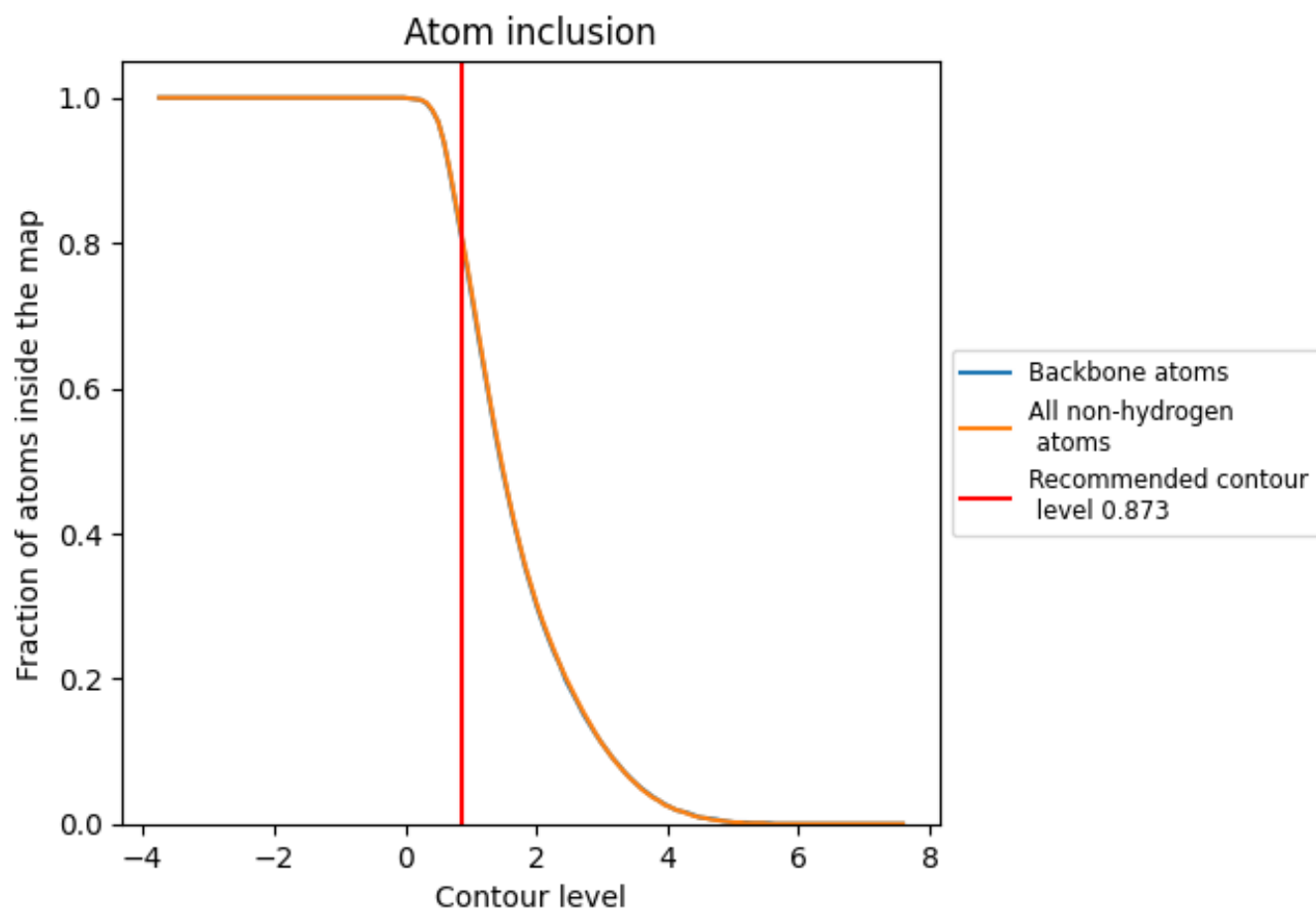











































9.4 Atom inclusion [i](#)



At the recommended contour level, 80% of all backbone atoms, 81% of all non-hydrogen atoms, are inside the map.

9.5 Map-model fit summary

The table lists the average atom inclusion at the recommended contour level (0.873) and Q-score for the entire model and for each chain.

Chain	Atom inclusion	Q-score
All	 0.8060	 0.4480
A	 0.8620	 0.5050
B	 0.8960	 0.5290
C	 0.9420	 0.5440
D	 0.0910	 0.1640
E	 0.8930	 0.4760
F	 0.8970	 0.5420
G	 0.2930	 0.2570
H	 0.9350	 0.5320
I	 0.7570	 0.4490
J	 0.9560	 0.5740
K	 0.9450	 0.5510
L	 0.8980	 0.4830
M	 0.6460	 0.2760
N	 0.7470	 0.2810
O	 0.8400	 0.4930
P	 0.7650	 0.4700
Q	 0.7610	 0.3910
T	 0.8530	 0.3680
a	 0.9020	 0.5180
b	 0.7170	 0.3140
c	 0.3100	 0.2670
d	 0.8320	 0.3790

