



Full wwPDB EM Validation Report ⓘ

Mar 6, 2026 – 06:30 PM UTC

PDB ID : 8FRU / pdb_00008fru
EMDB ID : EMD-29407
Title : 60S subunit of the Giardia lamblia 80S ribosome
Authors : Eiler, D.R.; Wimberly, B.T.; Bilodeau, D.Y.; Rissland, O.S.; Kieft, J.S.
Deposited on : 2023-01-08
Resolution : 2.49 Å (reported)

This is a Full wwPDB EM Validation Report for a publicly released PDB entry.

We welcome your comments at validation@mail.wwpdb.org

A user guide is available at

<https://www.wwpdb.org/validation/2017/EMValidationReportHelp>

with specific help available everywhere you see the ⓘ symbol.

The types of validation reports are described at

<http://www.wwpdb.org/validation/2017/FAQs#types>.

The following versions of software and data (see [references ⓘ](#)) were used in the production of this report:

EMDB validation analysis : 0.0.1.dev132
Mogul : 2022.3.0, CSD as543be (2022)
MolProbity : 4-5-2 with Phenix2.0
Percentile statistics : 20250101.v01 (using entries in the PDB archive January 1st 2025)
EM percentile statistics : 202505.v01 (Using data in the EMDB archive up until May 2025)
MapQ : 1.9.13
Ideal geometry (proteins) : Engh & Huber (2001)
Ideal geometry (DNA, RNA) : Parkinson et al. (1996)
Validation Pipeline (wwPDB-VP) : 2.49

1 Overall quality at a glance i

The following experimental techniques were used to determine the structure:
ELECTRON MICROSCOPY

The reported resolution of this entry is 2.49 Å.

Percentile scores (ranging between 0-100) for global validation metrics of the entry are shown in the following graphic. The table shows the number of entries on which the scores are based.

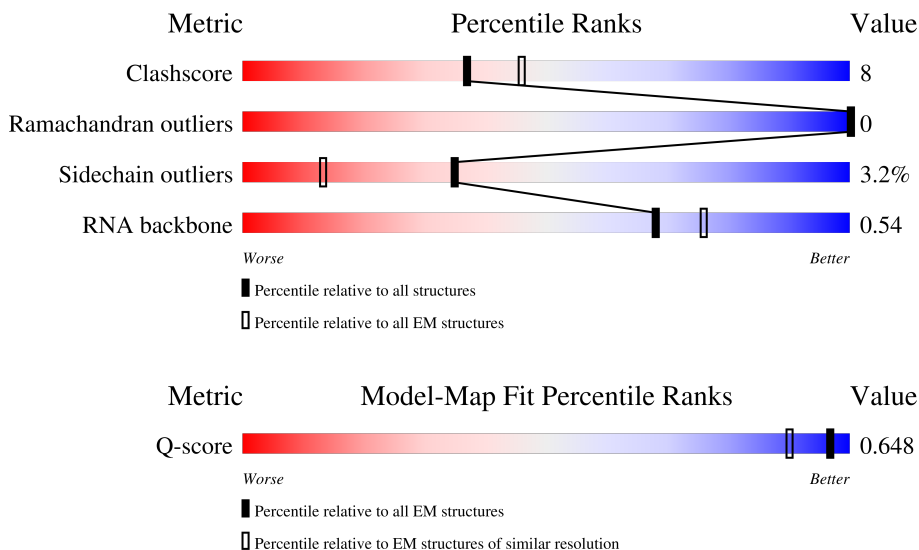

Metric	Whole archive (#Entries)	EM structures (#Entries)	Similar EM resolution (#Entries, resolution range(Å))
Clashscore	229148	23984	-
Ramachandran outliers	224038	23583	-
Sidechain outliers	223484	23102	-
RNA backbone	8273	3508	-
Q-score	-	25397	6237 (2.00 - 2.99)

The table below summarises the geometric issues observed across the polymeric chains and their fit to the map. The red, orange, yellow and green segments of the bar indicate the fraction of residues that contain outliers for ≥ 3 , 2, 1 and 0 types of geometric quality criteria respectively. A grey segment represents the fraction of residues that are not modelled. The numeric value for each fraction is indicated below the corresponding segment, with a dot representing fractions $\leq 5\%$. The upper red bar (where present) indicates the fraction of residues that have poor fit to the EM map (all-atom inclusion $< 40\%$). The numeric value is given above the bar.

Mol	Chain	Length	Quality of chain
1	B	379	84% 15%
2	a	149	85% 14%
3	C	316	78% 19%



Continued on next page...

Continued from previous page...

Mol	Chain	Length	Quality of chain
4	I	210	8% 68% 26% 6%
5	p	94	6% 71% 27% ..
6	D	297	18% 63% 32% ..
7	H	185	8% 62% 35% ..
8	G	225	13% 61% 24% 12%
9	J	173	21% 61% 31% 8%
10	O	197	5% 80% 18% ..
11	L	234	8% 72% 14% 14%
12	M	131	8% 70% 27% ..
13	N	204	84% 15%
14	Q	179	84% 16% .
15	S	205	5% 64% 20% 16%
16	R	196	16% 73% 19% 6%
17	T	159	8% 69% 25% ..
18	V	142	6% 77% 18% ..
19	P	164	9% 79% 15% 7%
20	X	141	58% 23% 18%
21	Y	135	6% 79% 20% .
22	W	102	55% 8% 37%
23	Z	135	20% 60% 36% ..
24	b	62	71% 21% 8%
25	h	124	10% 77% 20% ..
26	F	235	7% 67% 26% 6%
27	d	106	5% 64% 24% 8%
28	e	136	5% 74% 17% 9%

Continued on next page...

Continued from previous page...

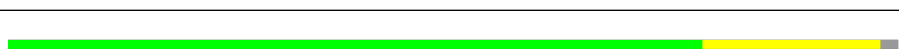
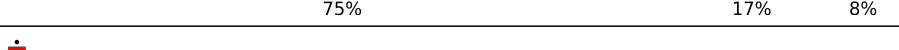
Mol	Chain	Length	Quality of chain
29	g	120	
30	f	123	
31	i	90	
32	k	77	
33	o	106	
34	U	171	
35	c	109	
36	j	100	
37	l	51	
38	m	127	
39	A	251	
40	n	25	
41	3	120	
42	4	141	
43	1	2687	

2 Entry composition [i](#)

There are 49 unique types of molecules in this entry. The entry contains 140991 atoms, of which 30508 are hydrogens and 0 are deuteriums.

In the tables below, the AltConf column contains the number of residues with at least one atom in alternate conformation and the Trace column contains the number of residues modelled with at most 2 atoms.

- Molecule 1 is a protein called 60S ribosomal protein uL3.

Mol	Chain	Residues	Atoms					AltConf	Trace
			Total	C	N	O	S		
1	B	378	Total	C	N	O	S	0	0
			2982	1884	565	512	21		

- Molecule 2 is a protein called 60S ribosomal protein uL15.

Mol	Chain	Residues	Atoms					AltConf	Trace
			Total	C	N	O	S		
2	a	148	Total	C	N	O	S	0	0
			1201	759	240	199	3		

- Molecule 3 is a protein called 60S ribosomal protein uL4.

Mol	Chain	Residues	Atoms					AltConf	Trace
			Total	C	N	O	S		
3	C	313	Total	C	N	O	S	0	0
			2430	1531	472	418	9		

- Molecule 4 is a protein called 60S ribosomal protein uL16.

Mol	Chain	Residues	Atoms					AltConf	Trace
			Total	C	N	O	S		
4	I	198	Total	C	N	O	S	0	0
			1610	1012	315	274	9		

- Molecule 5 is a protein called 60S ribosomal protein eL43.

Mol	Chain	Residues	Atoms					AltConf	Trace
			Total	C	N	O	S		
5	p	93	Total	C	N	O	S	0	0
			722	444	147	125	6		

- Molecule 6 is a protein called 60S ribosomal protein uL18.

Mol	Chain	Residues	Atoms					AltConf	Trace
			Total	C	N	O	S		
6	D	290	Total	C	N	O	S	0	0
			2323	1474	430	411	8		

- Molecule 7 is a protein called 60S ribosomal protein uL6.

Mol	Chain	Residues	Atoms					AltConf	Trace
			Total	C	N	O	S		
7	H	183	1439	912	262	254	11	0	0

- Molecule 8 is a protein called 60S ribosomal protein eL8.

Mol	Chain	Residues	Atoms					AltConf	Trace
			Total	C	N	O	S		
8	G	197	1573	1002	286	280	5	0	0

- Molecule 9 is a protein called 60S ribosomal protein uL5.

Mol	Chain	Residues	Atoms					AltConf	Trace
			Total	C	N	O	S		
9	J	159	1272	802	233	232	5	0	0

- Molecule 10 is a protein called 60S ribosomal protein uL13.

Mol	Chain	Residues	Atoms					AltConf	Trace
			Total	C	N	O	S		
10	O	196	1595	1003	311	269	12	0	0

- Molecule 11 is a protein called 60S ribosomal protein eL13.

Mol	Chain	Residues	Atoms					AltConf	Trace
			Total	C	N	O	S		
11	L	202	1611	1002	327	276	6	0	0

- Molecule 12 is a protein called 60S ribosomal protein eL14.

Mol	Chain	Residues	Atoms					AltConf	Trace
			Total	C	N	O	S		
12	M	130	1020	647	186	181	6	0	0

- Molecule 13 is a protein called 60S ribosomal protein eL15.

Mol	Chain	Residues	Atoms					AltConf	Trace
			Total	C	N	O	S		
13	N	203	1707	1080	357	264	6	0	0

- Molecule 14 is a protein called 60S ribosomal protein eL18.

Mol	Chain	Residues	Atoms					AltConf	Trace
			Total	C	N	O	S		
14	Q	179	1407	876	280	241	10	0	0

- Molecule 15 is a protein called 60S ribosomal protein eL20.

Mol	Chain	Residues	Atoms					AltConf	Trace
			Total	C	N	O	S		
15	S	173	1447	914	276	247	10	0	0

- Molecule 16 is a protein called 60S ribosomal protein eL19.

Mol	Chain	Residues	Atoms					AltConf	Trace
			Total	C	N	O	S		
16	R	184	1532	944	325	258	5	0	0

- Molecule 17 is a protein called 60S ribosomal protein eL21.

Mol	Chain	Residues	Atoms					AltConf	Trace
			Total	C	N	O	S		
17	T	153	1231	767	256	201	7	0	0

- Molecule 18 is a protein called 60S ribosomal protein uL14.

Mol	Chain	Residues	Atoms					AltConf	Trace
			Total	C	N	O	S		
18	V	137	1040	654	200	181	5	0	0

- Molecule 19 is a protein called 60S ribosomal protein uL22.

Mol	Chain	Residues	Atoms					AltConf	Trace
			Total	C	N	O	S		
19	P	153	1228	777	239	208	4	0	0

- Molecule 20 is a protein called 60S ribosomal protein uL23.

Mol	Chain	Residues	Atoms					AltConf	Trace
			Total	C	N	O	S		
20	X	116	936	601	169	163	3	0	0

- Molecule 21 is a protein called 60S ribosomal protein uL24.

Mol	Chain	Residues	Atoms					AltConf	Trace
21	Y	135	Total	C	N	O	S	0	0
			1087	671	222	186	8		

- Molecule 22 is a protein called 60S ribosomal protein eL24.

Mol	Chain	Residues	Atoms					AltConf	Trace
22	W	64	Total	C	N	O	S	0	0
			531	337	107	84	3		

- Molecule 23 is a protein called 60S ribosomal protein eL27.

Mol	Chain	Residues	Atoms					AltConf	Trace
23	Z	134	Total	C	N	O	S	0	0
			1062	666	200	189	7		

- Molecule 24 is a protein called 60S ribosomal protein eL29.

Mol	Chain	Residues	Atoms					AltConf	Trace
24	b	57	Total	C	N	O	S	0	0
			471	284	106	79	2		

- Molecule 25 is a protein called 60S ribosomal protein uL29.

Mol	Chain	Residues	Atoms					AltConf	Trace
25	h	122	Total	C	N	O	S	0	0
			985	628	190	162	5		

- Molecule 26 is a protein called 60S ribosomal protein uL30.

Mol	Chain	Residues	Atoms					AltConf	Trace
26	F	221	Total	C	N	O	S	0	0
			1776	1129	322	320	5		

- Molecule 27 is a protein called 60S ribosomal protein eL31.

Mol	Chain	Residues	Atoms					AltConf	Trace
27	d	97	Total	C	N	O	S	0	0
			795	507	155	132	1		

- Molecule 28 is a protein called 60S ribosomal protein eL32.

Mol	Chain	Residues	Atoms					AltConf	Trace
			Total	C	N	O	S		
28	e	124	1025	650	206	163	6	0	0

- Molecule 29 is a protein called 60S ribosomal protein eL34.

Mol	Chain	Residues	Atoms					AltConf	Trace
			Total	C	N	O	S		
29	g	97	782	483	162	132	5	0	0

- Molecule 30 is a protein called 60S ribosomal protein eL33.

Mol	Chain	Residues	Atoms					AltConf	Trace
			Total	C	N	O	S		
30	f	122	967	616	179	168	4	0	0

- Molecule 31 is a protein called 60S ribosomal protein eL36.

Mol	Chain	Residues	Atoms					AltConf	Trace
			Total	C	N	O	S		
31	i	83	677	430	135	108	4	0	0

- Molecule 32 is a protein called 60S ribosomal protein eL38.

Mol	Chain	Residues	Atoms					AltConf	Trace
			Total	C	N	O	S		
32	k	76	588	369	103	112	4	0	0

- Molecule 33 is a protein called 60S ribosomal protein eL42.

Mol	Chain	Residues	Atoms					AltConf	Trace
			Total	C	N	O	S		
33	o	93	767	478	159	125	5	0	0

- Molecule 34 is a protein called 60S ribosomal protein eL22.

Mol	Chain	Residues	Atoms					AltConf	Trace
			Total	C	N	O	S		
34	U	100	822	525	141	154	2	0	0

- Molecule 35 is a protein called 60S ribosomal protein eL30.

Mol	Chain	Residues	Atoms					AltConf	Trace
35	c	99	Total	C	N	O	S	0	0
			738	464	128	142	4		

- Molecule 36 is a protein called 60S ribosomal protein eL37.

Mol	Chain	Residues	Atoms					AltConf	Trace
36	j	88	Total	C	N	O	S	0	0
			707	432	151	117	7		

- Molecule 37 is a protein called 60S ribosomal protein eL39.

Mol	Chain	Residues	Atoms					AltConf	Trace
37	l	50	Total	C	N	O	S	0	0
			450	289	98	62	1		

- Molecule 38 is a protein called 60S ribosomal protein eL40.

Mol	Chain	Residues	Atoms					AltConf	Trace
38	m	50	Total	C	N	O	S	0	0
			414	252	87	68	7		

- Molecule 39 is a protein called 60S ribosomal protein uL2.

Mol	Chain	Residues	Atoms					AltConf	Trace
39	A	248	Total	C	N	O	S	0	0
			1857	1146	381	318	12		

- Molecule 40 is a protein called 60S ribosomal protein eL41.

Mol	Chain	Residues	Atoms				AltConf	Trace
40	n	25	Total	C	N	O	0	0
			125	75	25	25		

- Molecule 41 is a RNA chain called 5S rRNA.

Mol	Chain	Residues	Atoms					AltConf	Trace	
41	3	117	Total	C	H	N	O	P	0	0
			3762	1116	1265	457	808	116		

- Molecule 42 is a RNA chain called 5.8S rRNA.

Mol	Chain	Residues	Atoms						AltConf	Trace
			Total	C	H	N	O	P		
42	4	141	4550	1341	1536	560	973	140	0	0

There is a discrepancy between the modelled and reference sequences:

Chain	Residue	Modelled	Actual	Comment	Reference
4	138	C	-	insertion	GB 583967408

- Molecule 43 is a RNA chain called 28S rRNA.

Mol	Chain	Residues	Atoms						AltConf	Trace
			Total	C	H	N	O	P		
43	1	2551	82424	24325	27707	10140	17706	2546	0	0

There is a discrepancy between the modelled and reference sequences:

Chain	Residue	Modelled	Actual	Comment	Reference
1	1894	U	-	insertion	GB 2333213660

- Molecule 44 is POTASSIUM ION (CCD ID: K) (formula: K).

Mol	Chain	Residues	Atoms	AltConf
44	B	1	Total K 1 1	0
44	A	1	Total K 1 1	0
44	1	25	Total K 25 25	0

- Molecule 45 is MAGNESIUM ION (CCD ID: MG) (formula: Mg).

Mol	Chain	Residues	Atoms	AltConf
45	a	1	Total Mg 1 1	0
45	V	1	Total Mg 1 1	0
45	P	1	Total Mg 1 1	0
45	3	1	Total Mg 1 1	0
45	4	5	Total Mg 5 5	0

Continued on next page...

Continued from previous page...

Mol	Chain	Residues	Atoms		AltConf
45	1	120	Total	Mg	0
			120	120	

- Molecule 46 is ZINC ION (CCD ID: ZN) (formula: Zn).

Mol	Chain	Residues	Atoms		AltConf
46	j	1	Total	Zn	0
			1	1	
46	m	1	Total	Zn	0
			1	1	

- Molecule 47 is SODIUM ION (CCD ID: NA) (formula: Na).

Mol	Chain	Residues	Atoms		AltConf
47	4	2	Total	Na	0
			2	2	
47	1	31	Total	Na	0
			31	31	

- Molecule 48 is SPERMIDINE (CCD ID: SPD) (formula: C₇H₁₉N₃).

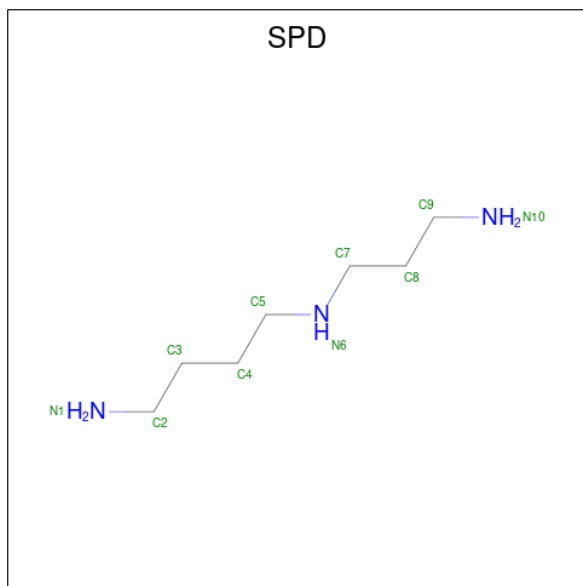

Mol	Chain	Residues	Atoms			AltConf
48	1	1	Total	C	N	0
			10	7	3	

- Molecule 49 is water.

Mol	Chain	Residues	Atoms		AltConf
49	B	31	Total 31	O 31	0
49	a	33	Total 33	O 33	0
49	C	34	Total 34	O 34	0
49	I	11	Total 11	O 11	0
49	p	1	Total 1	O 1	0
49	D	7	Total 7	O 7	0
49	H	4	Total 4	O 4	0
49	G	5	Total 5	O 5	0
49	O	9	Total 9	O 9	0
49	L	23	Total 23	O 23	0
49	N	45	Total 45	O 45	0
49	Q	11	Total 11	O 11	0
49	S	2	Total 2	O 2	0
49	R	8	Total 8	O 8	0
49	T	24	Total 24	O 24	0
49	V	6	Total 6	O 6	0
49	P	18	Total 18	O 18	0
49	X	9	Total 9	O 9	0
49	Y	6	Total 6	O 6	0
49	W	1	Total 1	O 1	0
49	Z	1	Total 1	O 1	0
49	b	7	Total 7	O 7	0

Continued on next page...

Continued from previous page...

Mol	Chain	Residues	Atoms		AltConf
49	h	2	Total 2	O 2	0
49	F	4	Total 4	O 4	0
49	d	3	Total 3	O 3	0
49	e	20	Total 20	O 20	0
49	g	12	Total 12	O 12	0
49	f	9	Total 9	O 9	0
49	i	2	Total 2	O 2	0
49	o	12	Total 12	O 12	0
49	j	23	Total 23	O 23	0
49	l	14	Total 14	O 14	0
49	A	23	Total 23	O 23	0
49	n	2	Total 2	O 2	0
49	3	29	Total 29	O 29	0
49	4	150	Total 150	O 150	0
49	1	2521	Total 2521	O 2521	0

3 Residue-property plots [i](#)

These plots are drawn for all protein, RNA, DNA and oligosaccharide chains in the entry. The first graphic for a chain summarises the proportions of the various outlier classes displayed in the second graphic. The second graphic shows the sequence view annotated by issues in geometry and atom inclusion in map density. Residues are color-coded according to the number of geometric quality criteria for which they contain at least one outlier: green = 0, yellow = 1, orange = 2 and red = 3 or more. A red diamond above a residue indicates a poor fit to the EM map for this residue (all-atom inclusion < 40%). Stretches of 2 or more consecutive residues without any outlier are shown as a green connector. Residues present in the sample, but not in the model, are shown in grey.

- Molecule 1: 60S ribosomal protein uL3

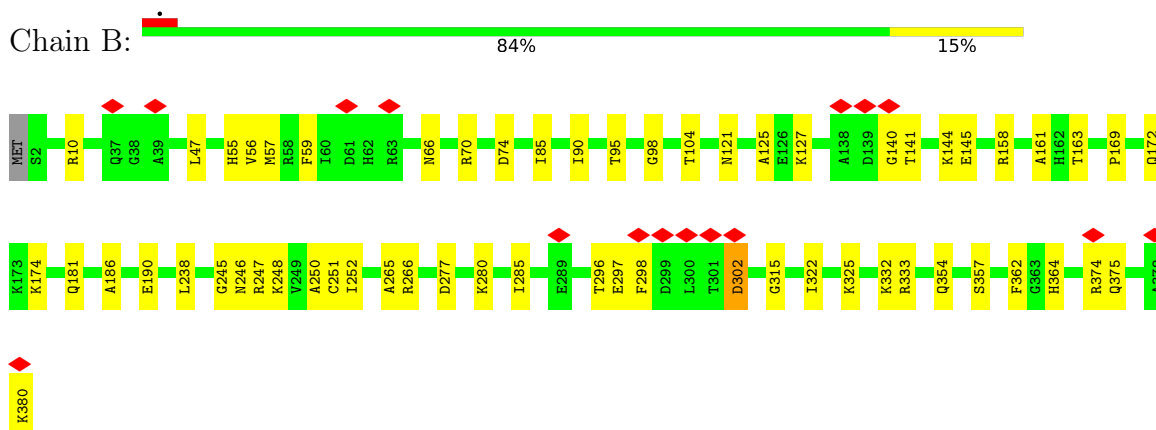

- Molecule 2: 60S ribosomal protein uL15

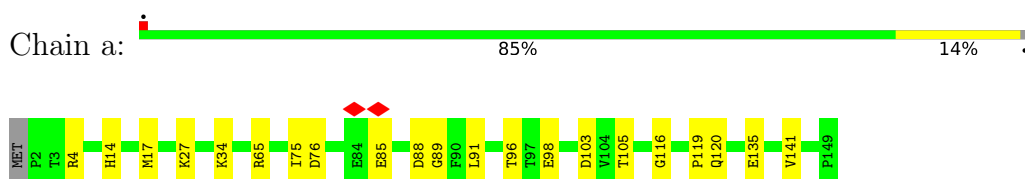

- Molecule 3: 60S ribosomal protein uL4

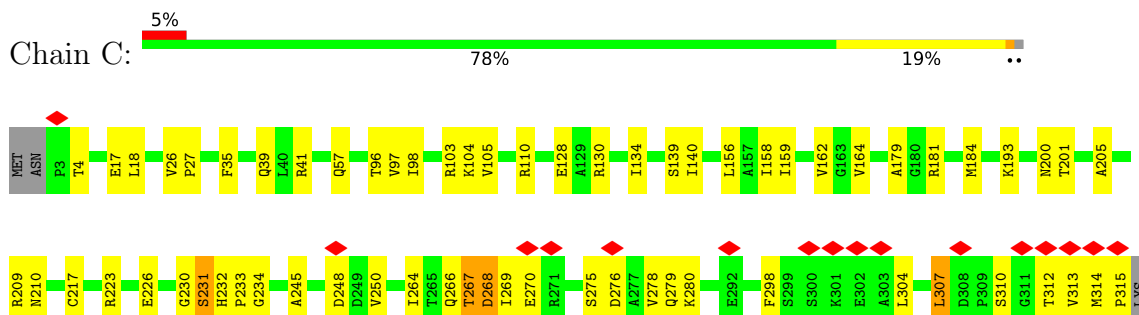

- Molecule 4: 60S ribosomal protein uL16



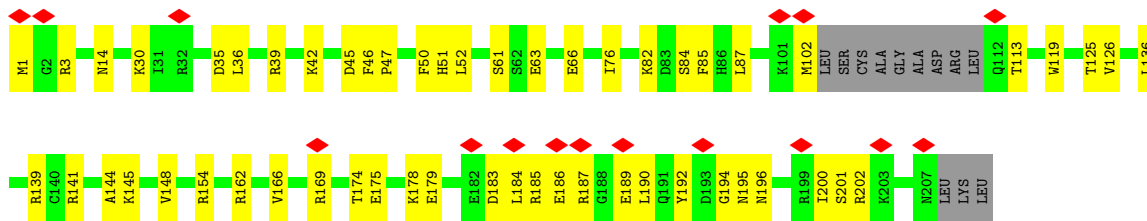

• Molecule 5: 60S ribosomal protein eL43



• Molecule 6: 60S ribosomal protein uL18



• Molecule 7: 60S ribosomal protein uL6

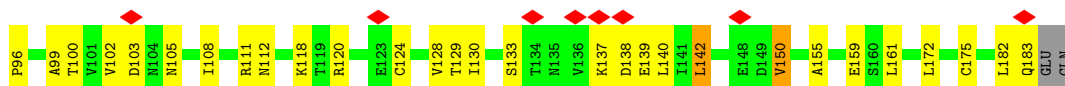

• Molecule 8: 60S ribosomal protein eL8



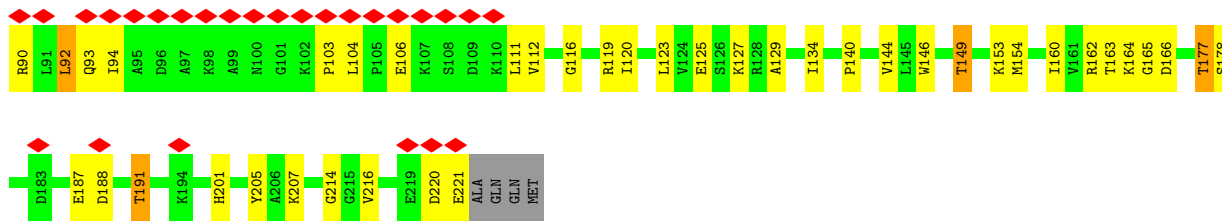

• Molecule 9: 60S ribosomal protein uL5

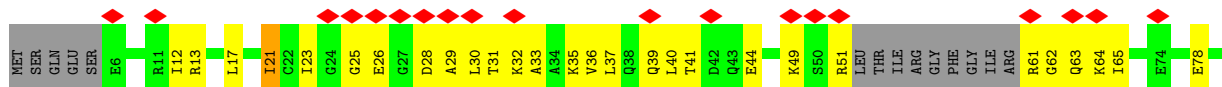

• Molecule 10: 60S ribosomal protein uL13

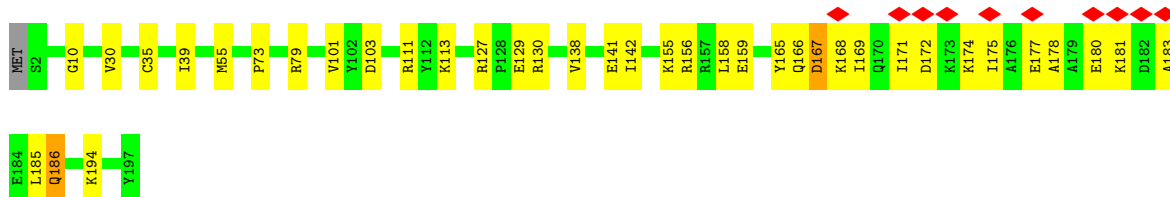
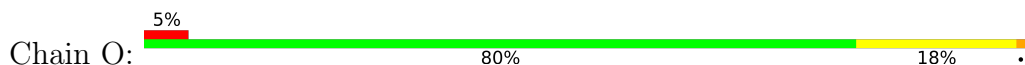

• Molecule 11: 60S ribosomal protein eL13

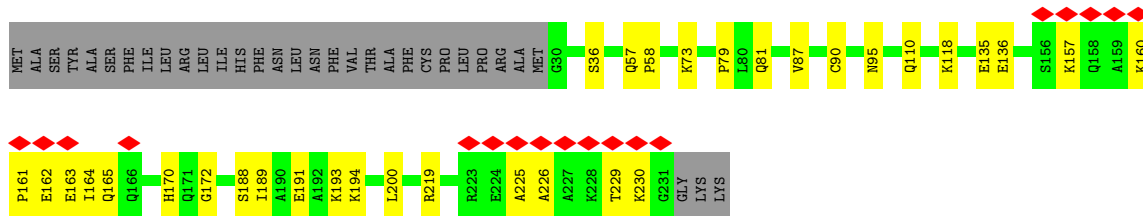

• Molecule 12: 60S ribosomal protein eL14

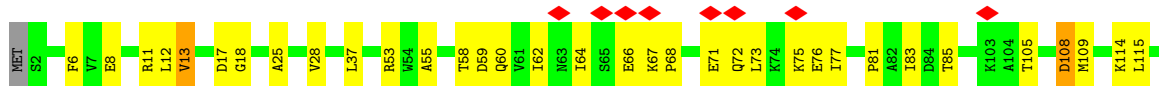

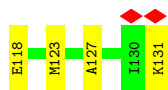

• Molecule 13: 60S ribosomal protein eL15

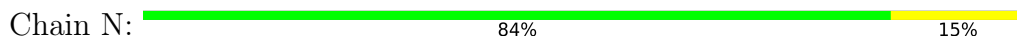

• Molecule 14: 60S ribosomal protein eL18

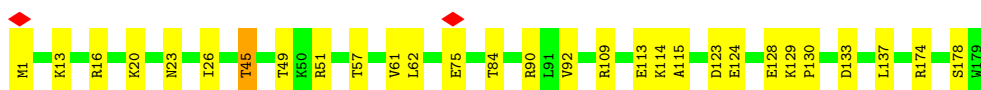
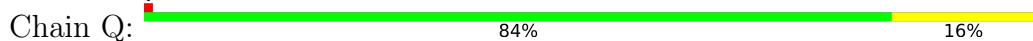

• Molecule 15: 60S ribosomal protein eL20

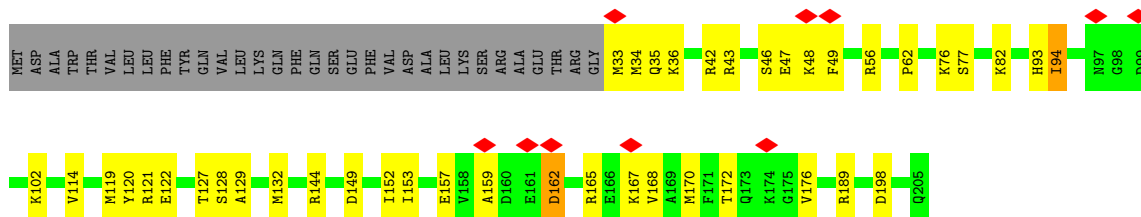

• Molecule 16: 60S ribosomal protein eL19

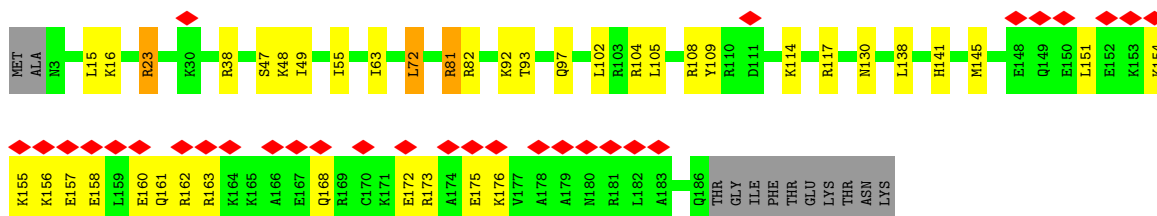
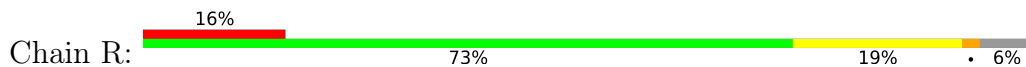

• Molecule 17: 60S ribosomal protein eL21



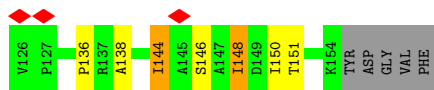

• Molecule 18: 60S ribosomal protein uL14

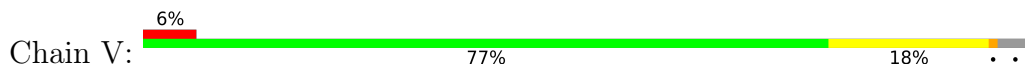

• Molecule 19: 60S ribosomal protein uL22

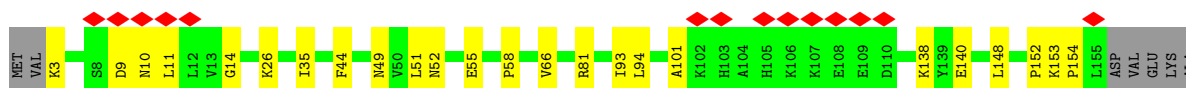
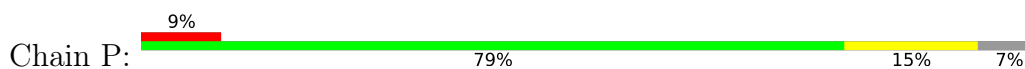

• Molecule 20: 60S ribosomal protein uL23

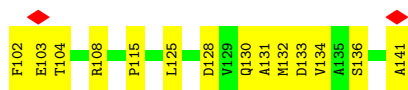
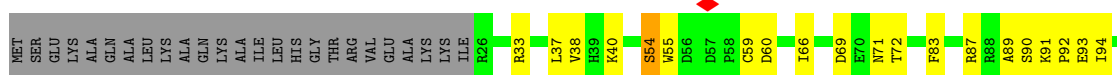

• Molecule 21: 60S ribosomal protein uL24

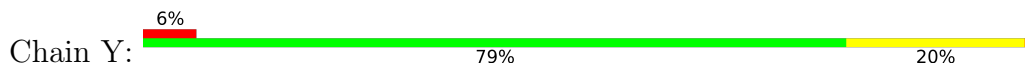

• Molecule 22: 60S ribosomal protein eL24

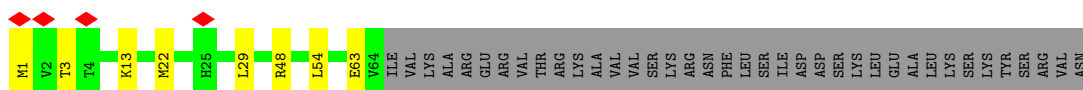

• Molecule 23: 60S ribosomal protein eL27

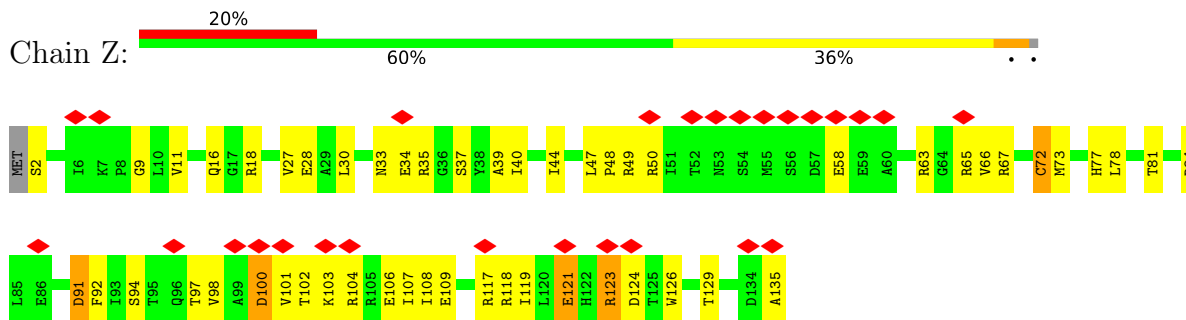

• Molecule 24: 60S ribosomal protein eL29

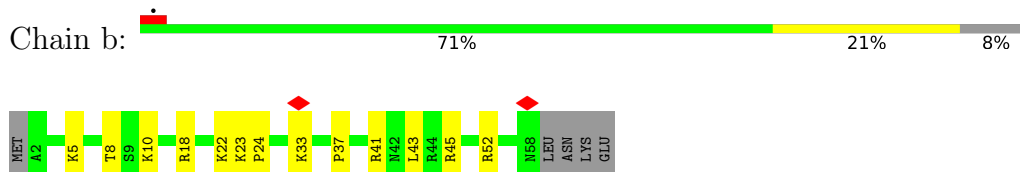

• Molecule 25: 60S ribosomal protein uL29

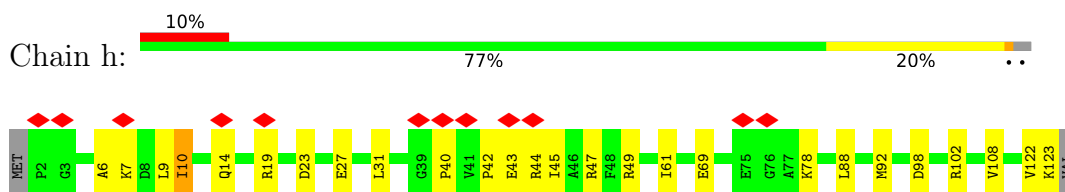

• Molecule 26: 60S ribosomal protein uL30

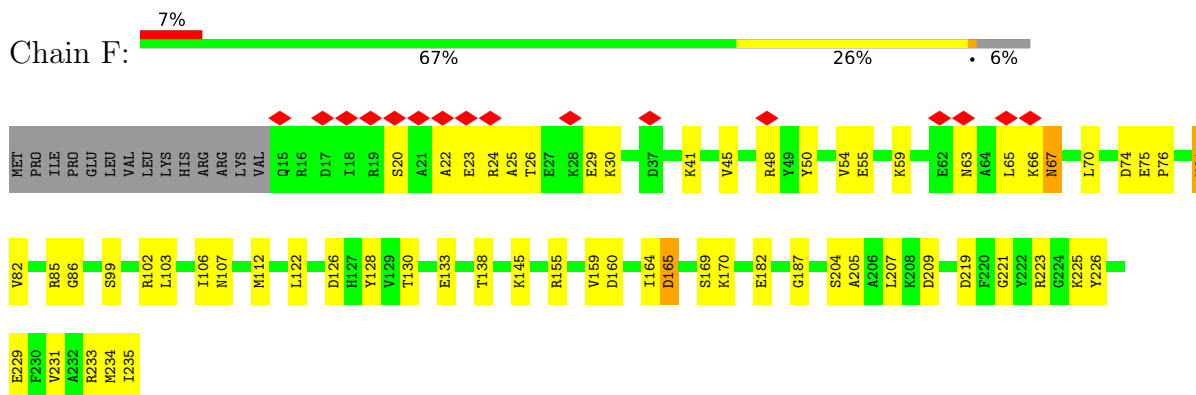

• Molecule 27: 60S ribosomal protein eL31

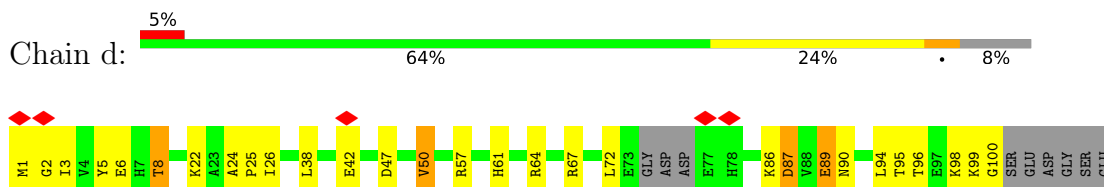

• Molecule 28: 60S ribosomal protein eL32

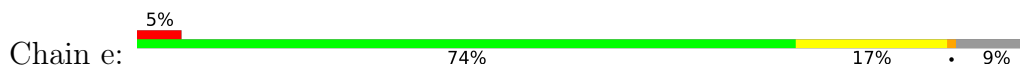



• Molecule 29: 60S ribosomal protein eL34

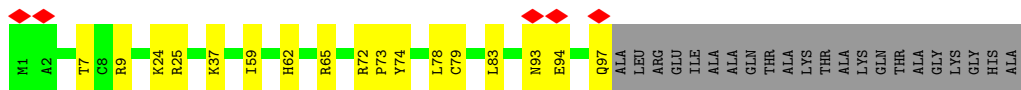

• Molecule 30: 60S ribosomal protein eL33

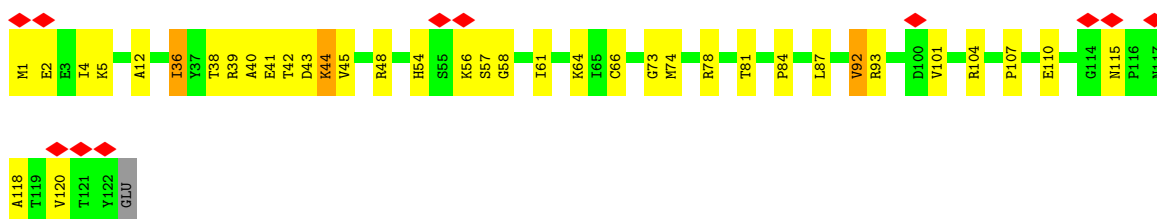

• Molecule 31: 60S ribosomal protein eL36

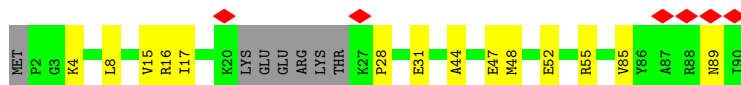
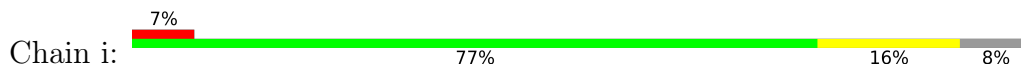

• Molecule 32: 60S ribosomal protein eL38

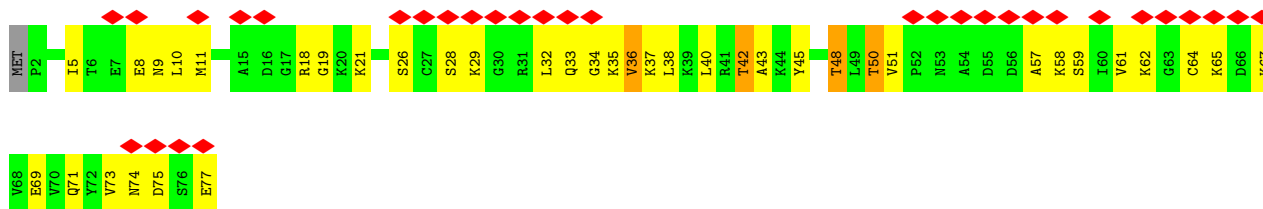

• Molecule 33: 60S ribosomal protein eL42

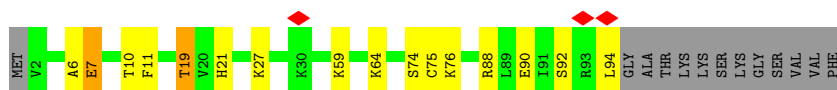

• Molecule 34: 60S ribosomal protein eL22

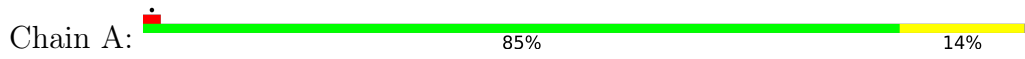

• Molecule 40: 60S ribosomal protein eL41



• Molecule 41: 5S rRNA

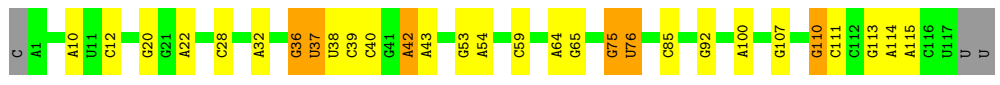

• Molecule 42: 5.8S rRNA

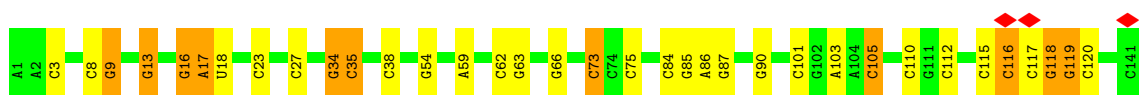
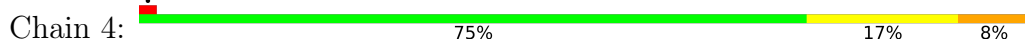

• Molecule 43: 28S rRNA

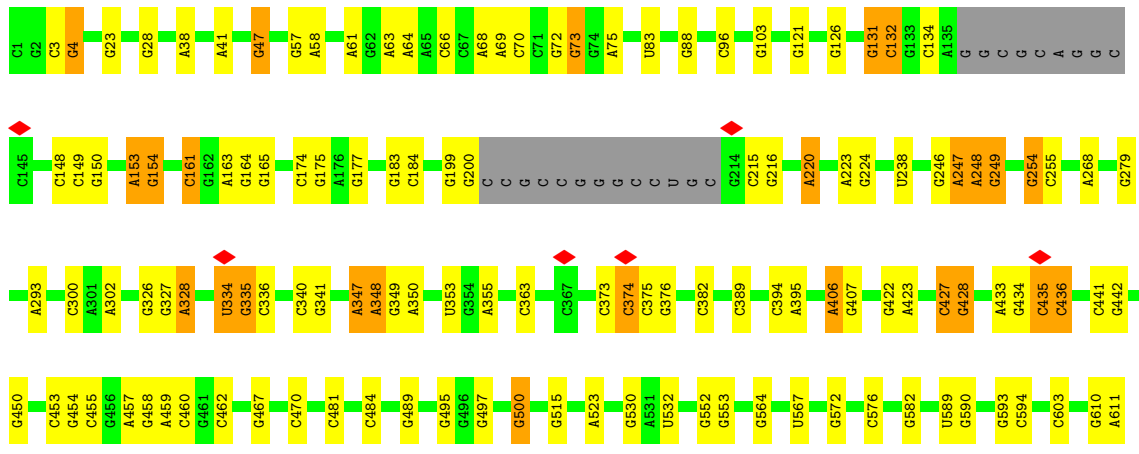

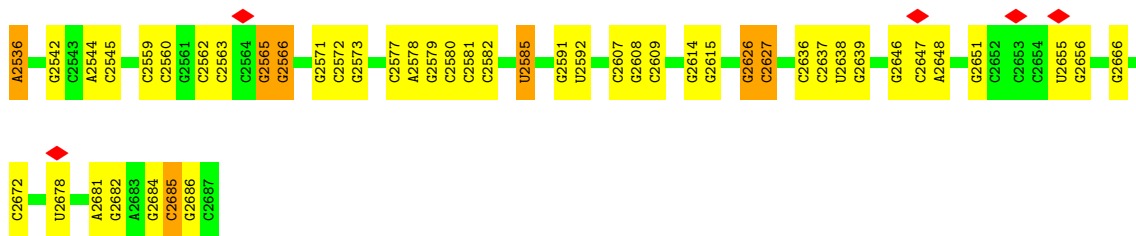

4 Experimental information

Property	Value	Source
EM reconstruction method	SINGLE PARTICLE	Depositor
Imposed symmetry	POINT, Not provided	
Number of particles used	289618	Depositor
Resolution determination method	FSC 0.143 CUT-OFF	Depositor
CTF correction method	PHASE FLIPPING AND AMPLITUDE CORRECTION	Depositor
Microscope	TFS KRIOS	Depositor
Voltage (kV)	300	Depositor
Electron dose ($e^-/\text{\AA}^2$)	72.26	Depositor
Minimum defocus (nm)	500	Depositor
Maximum defocus (nm)	1900	Depositor
Magnification	Not provided	
Image detector	GATAN K3 (6k x 4k)	Depositor
Maximum map value	3.990	Depositor
Minimum map value	-1.460	Depositor
Average map value	-0.001	Depositor
Map value standard deviation	0.152	Depositor
Recommended contour level	0.461	Depositor
Map size (Å)	369.495, 369.495, 369.495	wwPDB
Map dimensions	450, 450, 450	wwPDB
Map angles (°)	90.0, 90.0, 90.0	wwPDB
Pixel spacing (Å)	0.8211, 0.8211, 0.8211	Depositor

5 Model quality [i](#)

5.1 Standard geometry [i](#)

Bond lengths and bond angles in the following residue types are not validated in this section: NA, ZN, MG, SPD, K

The Z score for a bond length (or angle) is the number of standard deviations the observed value is removed from the expected value. A bond length (or angle) with $|Z| > 5$ is considered an outlier worth inspection. RMSZ is the root-mean-square of all Z scores of the bond lengths (or angles).

Mol	Chain	Bond lengths		Bond angles	
		RMSZ	$\# Z > 5$	RMSZ	$\# Z > 5$
1	B	0.23	0/3053	0.33	0/4122
2	a	0.26	0/1231	0.34	0/1647
3	C	0.23	0/2482	0.35	0/3368
4	I	0.21	0/1646	0.30	0/2203
5	p	0.23	0/731	0.39	0/975
6	D	0.20	0/2365	0.34	1/3172 (0.0%)
7	H	0.20	0/1466	0.31	0/1980
8	G	0.21	0/1603	0.36	0/2167
9	J	0.17	0/1295	0.27	0/1739
10	O	0.23	0/1627	0.31	0/2182
11	L	0.22	0/1634	0.32	0/2188
12	M	0.20	0/1033	0.25	0/1385
13	N	0.27	0/1750	0.36	0/2346
14	Q	0.22	0/1430	0.30	0/1913
15	S	0.22	0/1482	0.30	0/1991
16	R	0.21	0/1548	0.30	0/2047
17	T	0.24	0/1255	0.33	0/1686
18	V	0.22	0/1060	0.34	0/1430
19	P	0.23	0/1254	0.31	0/1677
20	X	0.21	0/956	0.34	0/1293
21	Y	0.23	0/1102	0.32	0/1467
22	W	0.22	0/542	0.30	0/724
23	Z	0.18	0/1080	0.31	0/1458
24	b	0.23	0/479	0.35	0/635
25	h	0.22	0/998	0.34	0/1330
26	F	0.24	0/1806	0.36	0/2436
27	d	0.22	0/808	0.29	0/1083
28	e	0.24	0/1047	0.34	0/1394
29	g	0.23	0/797	0.30	0/1070
30	f	0.23	0/987	0.36	0/1328
31	i	0.20	0/686	0.30	0/909
32	k	0.16	0/592	0.31	0/790

Mol	Chain	Bond lengths		Bond angles	
		RMSZ	# Z >5	RMSZ	# Z >5
33	o	0.21	0/778	0.29	0/1029
34	U	0.16	0/838	0.33	0/1127
35	c	0.20	0/746	0.34	0/1011
36	j	0.28	0/722	0.41	0/956
37	l	0.25	0/460	0.28	0/609
38	m	0.22	0/419	0.36	0/558
39	A	0.26	0/1890	0.40	0/2539
41	3	0.28	0/2793	0.32	0/4354
42	4	0.34	0/3367	0.38	0/5253
43	1	0.34	0/61178	0.38	0/95481
All	All	0.30	0/115016	0.36	1/169052 (0.0%)

There are no bond length outliers.

All (1) bond angle outliers are listed below:

Mol	Chain	Res	Type	Atoms	Z	Observed(°)	Ideal(°)
6	D	257	PRO	CA-N-CD	-7.41	101.63	112.00

There are no chirality outliers.

There are no planarity outliers.

5.2 Too-close contacts [i](#)

In the following table, the Non-H and H(model) columns list the number of non-hydrogen atoms and hydrogen atoms in the chain respectively. The H(added) column lists the number of hydrogen atoms added and optimized by MolProbity. The Clashes column lists the number of clashes within the asymmetric unit, whereas Symm-Clashes lists symmetry-related clashes.

Mol	Chain	Non-H	H(model)	H(added)	Clashes	Symm-Clashes
1	B	2982	0	3021	46	0
2	a	1201	0	1233	21	0
3	C	2430	0	2516	50	0
4	I	1610	0	1621	52	0
5	p	722	0	762	23	0
6	D	2323	0	2380	104	0
7	H	1439	0	1489	52	0
8	G	1573	0	1649	47	0
9	J	1272	0	1275	58	0
10	O	1595	0	1634	28	0
11	L	1611	0	1710	30	0

Continued on next page...

Continued from previous page...

Mol	Chain	Non-H	H(model)	H(added)	Clashes	Symm-Clashes
12	M	1020	0	1087	35	0
13	N	1707	0	1785	24	0
14	Q	1407	0	1487	24	0
15	S	1447	0	1450	35	0
16	R	1532	0	1636	39	0
17	T	1231	0	1272	40	0
18	V	1040	0	1075	16	0
19	P	1228	0	1263	19	0
20	X	936	0	984	27	0
21	Y	1087	0	1149	18	0
22	W	531	0	563	9	0
23	Z	1062	0	1089	50	0
24	b	471	0	495	15	0
25	h	985	0	1091	21	0
26	F	1776	0	1805	46	0
27	d	795	0	849	23	0
28	e	1025	0	1083	16	0
29	g	782	0	815	14	0
30	f	967	0	993	31	0
31	i	677	0	735	12	0
32	k	588	0	628	37	0
33	o	767	0	825	12	0
34	U	822	0	811	49	0
35	c	738	0	755	43	0
36	j	707	0	703	9	0
37	l	450	0	500	11	0
38	m	414	0	428	6	0
39	A	1857	0	1906	29	0
40	n	125	0	27	0	0
41	3	2497	1265	1266	17	0
42	4	3014	1536	1542	30	0
43	1	54717	27707	27810	298	0
44	1	25	0	0	0	0
44	A	1	0	0	0	0
44	B	1	0	0	0	0
45	1	120	0	0	0	0
45	3	1	0	0	0	0
45	4	5	0	0	0	0
45	P	1	0	0	0	0
45	V	1	0	0	0	0
45	a	1	0	0	0	0
46	j	1	0	0	0	0

Continued on next page...

Continued from previous page...

Mol	Chain	Non-H	H(model)	H(added)	Clashes	Symm-Clashes
46	m	1	0	0	0	0
47	1	31	0	0	0	0
47	4	2	0	0	0	0
48	1	10	0	19	0	0
49	1	2521	0	0	63	0
49	3	29	0	0	2	0
49	4	150	0	0	5	0
49	A	23	0	0	2	0
49	B	31	0	0	2	0
49	C	34	0	0	3	0
49	D	7	0	0	0	0
49	F	4	0	0	1	0
49	G	5	0	0	0	0
49	H	4	0	0	1	0
49	I	11	0	0	0	0
49	L	23	0	0	1	0
49	N	45	0	0	4	0
49	O	9	0	0	0	0
49	P	18	0	0	2	0
49	Q	11	0	0	0	0
49	R	8	0	0	1	0
49	S	2	0	0	0	0
49	T	24	0	0	3	0
49	V	6	0	0	0	0
49	W	1	0	0	0	0
49	X	9	0	0	2	0
49	Y	6	0	0	0	0
49	Z	1	0	0	1	0
49	a	33	0	0	2	0
49	b	7	0	0	0	0
49	d	3	0	0	0	0
49	e	20	0	0	0	0
49	f	9	0	0	1	0
49	g	12	0	0	0	0
49	h	2	0	0	1	0
49	i	2	0	0	0	0
49	j	23	0	0	0	0
49	l	14	0	0	3	0
49	n	2	0	0	0	0
49	o	12	0	0	0	0
49	p	1	0	0	0	0
All	All	110483	30508	79216	1413	0

The all-atom clashscore is defined as the number of clashes found per 1000 atoms (including hydrogen atoms). The all-atom clashscore for this structure is 8.

All (1413) close contacts within the same asymmetric unit are listed below, sorted by their clash magnitude.

Atom-1	Atom-2	Interatomic distance (Å)	Clash overlap (Å)
35:c:48:MET:HE1	35:c:57:LYS:HG2	1.40	1.02
11:L:162:GLU:OE1	11:L:162:GLU:N	2.07	0.86
43:1:103:G:O6	49:1:2902:HOH:O	1.94	0.86
43:1:1880:G:OP1	49:1:2901:HOH:O	1.92	0.85
14:Q:23:ASN:HB3	14:Q:26:ILE:HD12	1.60	0.84
38:m:104:PRO:HG2	38:m:107:ALA:HB2	1.60	0.83
43:1:1294:C:O2	43:1:1454:C:N4	2.10	0.83
35:c:34:ALA:O	35:c:38:ILE:HG13	1.79	0.83
43:1:2259:A:N6	43:1:2271:G:O2'	2.13	0.82
11:L:163:GLU:OE2	11:L:164:ILE:HG12	1.81	0.81
43:1:2274:G:OP2	49:1:2903:HOH:O	1.98	0.81
13:N:172:ARG:HD3	43:1:28:G:H5''	1.61	0.81
43:1:293:A:OP2	49:1:2904:HOH:O	1.99	0.81
43:1:1858:A:N1	49:1:2939:HOH:O	2.14	0.80
2:a:14:HIS:O	49:a:301:HOH:O	1.99	0.80
9:J:106:ILE:HD13	9:J:112:LEU:HD21	1.63	0.80
35:c:72:ARG:HD3	35:c:108:LEU:HB3	1.63	0.80
6:D:291:ALA:O	6:D:295:LEU:HG	1.81	0.80
43:1:1498:G:N7	49:1:2942:HOH:O	2.15	0.80
4:I:169:ARG:HG3	4:I:169:ARG:HH11	1.47	0.79
9:J:26:GLU:HG2	9:J:64:LYS:HB2	1.64	0.79
43:1:1256:C:OP1	49:1:2907:HOH:O	2.00	0.79
1:B:140:GLY:O	1:B:144:LYS:HG2	1.83	0.79
14:Q:61:VAL:HG12	14:Q:84:THR:HG23	1.65	0.79
43:1:2430:G:OP2	49:1:2908:HOH:O	2.01	0.79
10:O:181:LYS:HE3	10:O:181:LYS:HA	1.64	0.79
43:1:427:C:OP2	49:1:2905:HOH:O	2.00	0.79
43:1:1563:A:OP2	49:1:2906:HOH:O	2.00	0.79
12:M:81:PRO:O	12:M:85:THR:HG22	1.82	0.79
43:1:1905:A:OP2	49:1:2912:HOH:O	2.01	0.79
32:k:26:SER:OG	32:k:74:ASN:OD1	2.00	0.78
5:p:79:ALA:O	5:p:83:ILE:HG12	1.84	0.78
6:D:286:ALA:HA	6:D:289:LEU:HD21	1.65	0.78
43:1:898:C:N4	43:1:900:G:O6	2.16	0.78
43:1:1414:C:O2'	43:1:1415:C:OP1	2.02	0.78
43:1:2307:U:O4	49:1:2911:HOH:O	2.01	0.78
6:D:270:VAL:HG23	6:D:273:ALA:HB3	1.64	0.77

Continued on next page...

Continued from previous page...

Atom-1	Atom-2	Interatomic distance (Å)	Clash overlap (Å)
34:U:116:THR:CG2	34:U:119:TYR:HB3	2.13	0.77
35:c:87:ARG:HH11	35:c:87:ARG:HG2	1.49	0.77
43:1:406:A:OP1	49:1:2913:HOH:O	2.02	0.77
43:1:1793:G:O2'	43:1:1796:U:OP2	2.02	0.77
3:C:266:GLN:O	3:C:269:ILE:HG22	1.83	0.77
23:Z:106:GLU:HA	23:Z:109:GLU:OE2	1.84	0.77
41:3:65:G:O6	49:3:301:HOH:O	2.02	0.77
11:L:90:CYS:O	49:L:301:HOH:O	2.02	0.77
28:e:105:VAL:O	28:e:110:ARG:NH1	2.16	0.77
3:C:267:THR:HA	3:C:270:GLU:OE2	1.84	0.76
6:D:81:HIS:O	6:D:84:PRO:HD2	1.84	0.76
43:1:2530:G:N7	49:1:2949:HOH:O	2.18	0.76
20:X:108:ARG:NH2	43:1:1279:C:OP1	2.18	0.76
1:B:296:THR:HG22	1:B:297:GLU:H	1.50	0.76
2:a:103:ASP:OD1	2:a:105:THR:OG1	2.04	0.76
43:1:2580:C:OP2	49:1:2915:HOH:O	2.03	0.76
6:D:212:ASP:O	6:D:216:GLU:HG2	1.85	0.75
15:S:48:LYS:HE3	15:S:49:PHE:CZ	2.21	0.75
24:b:23:LYS:HE2	24:b:24:PRO:HD2	1.68	0.75
34:U:155:LYS:NZ	34:U:156:PRO:O	2.19	0.75
43:1:2239:U:OP1	49:1:2914:HOH:O	2.03	0.75
43:1:1276:A:OP2	49:1:2917:HOH:O	2.05	0.75
5:p:92:ASP:OD1	5:p:93:ALA:N	2.19	0.75
34:U:120:GLU:OE1	34:U:120:GLU:HA	1.87	0.75
7:H:7:MET:SD	7:H:67:ARG:NH1	2.60	0.75
43:1:2096:A:O2'	43:1:2097:C:OP2	2.02	0.75
5:p:6:LYS:HB3	5:p:6:LYS:NZ	2.00	0.75
6:D:206:MET:HB3	6:D:243:GLU:HG2	1.67	0.75
15:S:33:MET:HE3	15:S:33:MET:O	1.87	0.74
5:p:87:ARG:NH1	39:A:96:LEU:O	2.20	0.74
19:P:138:LYS:HD3	19:P:140:GLU:HG3	1.69	0.74
43:1:497:G:OP1	49:1:2919:HOH:O	2.05	0.74
43:1:834:G:OP2	49:1:2922:HOH:O	2.06	0.74
17:T:108:ARG:NH2	43:1:806:G:O2'	2.20	0.74
28:e:67:GLU:HA	28:e:67:GLU:OE2	1.86	0.74
43:1:1000:A:O2'	43:1:1001:A:OP2	2.06	0.74
34:U:116:THR:HG21	34:U:119:TYR:HB3	1.68	0.74
1:B:141:THR:O	1:B:145:GLU:HG3	1.87	0.74
25:h:49:ARG:NH2	49:h:201:HOH:O	2.20	0.74
43:1:1631:A:OP1	49:1:2921:HOH:O	2.06	0.74
4:I:30:LYS:HD3	4:I:63:GLU:HG3	1.70	0.74

Continued on next page...

Continued from previous page...

Atom-1	Atom-2	Interatomic distance (Å)	Clash overlap (Å)
42:4:8:C:O2'	42:4:9:G:O5'	2.05	0.74
10:O:185:LEU:HD21	12:M:123:MET:HE1	1.69	0.73
17:T:138:ALA:HA	26:F:74:ASP:OD1	1.88	0.73
7:H:155:ALA:O	7:H:159:GLU:HG3	1.88	0.73
26:F:207:LEU:HB3	26:F:219:ASP:OD2	1.88	0.73
8:G:123:LEU:HD13	8:G:129:ALA:HB2	1.68	0.73
6:D:99:TYR:OH	6:D:176:ASP:OD2	2.05	0.73
43:1:861:A:OP2	49:1:2918:HOH:O	2.05	0.73
8:G:163:THR:HG22	8:G:165:GLY:H	1.51	0.73
15:S:168:VAL:O	15:S:172:THR:HG23	1.88	0.73
39:A:117:GLU:HB2	39:A:122:ASP:OD1	1.89	0.72
43:1:1136:G:OP2	49:1:2920:HOH:O	2.06	0.72
5:p:49:ARG:NH2	43:1:1434:C:OP2	2.22	0.72
17:T:118:LEU:O	17:T:121:GLU:HG3	1.90	0.72
9:J:21:ILE:HD13	9:J:33:ALA:HB1	1.71	0.72
10:O:183:ALA:HA	10:O:186:GLN:HG3	1.72	0.72
20:X:33:ARG:O	49:X:201:HOH:O	2.08	0.72
43:1:1768:U:OP1	43:1:2393:G:O2'	2.06	0.72
5:p:90:ARG:NH1	39:A:106:ASN:O	2.20	0.72
16:R:82:ARG:NH1	16:R:82:ARG:HB3	2.05	0.72
43:1:523:A:OP2	49:1:2924:HOH:O	2.07	0.72
21:Y:26:ARG:O	21:Y:30:MET:HG3	1.90	0.72
23:Z:49:ARG:HB3	23:Z:63:ARG:O	1.89	0.72
3:C:181:ARG:NH2	49:C:402:HOH:O	2.22	0.71
9:J:65:ILE:HD11	43:1:2103:C:H5'	1.72	0.71
34:U:70:SER:HA	34:U:73:LYS:HD3	1.72	0.71
23:Z:117:ARG:NH1	23:Z:117:ARG:HB3	2.04	0.71
27:d:2:GLY:O	27:d:100:GLY:HA3	1.89	0.71
24:b:23:LYS:HE2	24:b:24:PRO:CD	2.20	0.71
9:J:142:ARG:NH1	43:1:2086:C:OP2	2.23	0.71
34:U:141:VAL:HG22	34:U:142:PHE:HD1	1.56	0.71
6:D:222:GLU:O	6:D:226:ARG:HG3	1.91	0.71
35:c:14:ILE:O	35:c:17:THR:HG22	1.91	0.71
43:1:2099:G:O2'	43:1:2101:G:N2	2.24	0.71
30:f:38:THR:O	30:f:42:THR:HG23	1.90	0.71
23:Z:94:SER:H	23:Z:97:THR:HG22	1.55	0.71
24:b:5:LYS:HE2	24:b:8:THR:OG1	1.90	0.71
28:e:111:LYS:O	28:e:115:GLU:HG3	1.91	0.71
43:1:1526:A:OP2	49:1:2925:HOH:O	2.09	0.71
8:G:125:GLU:HA	8:G:154:MET:HE3	1.73	0.71
6:D:286:ALA:HA	6:D:289:LEU:CD2	2.20	0.70

Continued on next page...

Continued from previous page...

Atom-1	Atom-2	Interatomic distance (Å)	Clash overlap (Å)
37:l:29:LEU:HD12	37:l:30:LYS:N	2.06	0.70
41:3:37:U:O2'	41:3:42:A:N6	2.20	0.70
2:a:98:GLU:OE1	2:a:98:GLU:HA	1.91	0.70
8:G:36:ARG:O	8:G:40:ILE:HG12	1.91	0.70
28:e:91:PHE:C	28:e:92:MET:HE2	2.16	0.70
20:X:132:MET:HE3	20:X:132:MET:O	1.92	0.70
26:F:48:ARG:HB2	26:F:48:ARG:NH1	2.05	0.70
26:F:107:ASN:ND2	26:F:204:SER:HA	2.06	0.70
34:U:122:ALA:HB1	43:1:1340:G:OP2	1.91	0.70
33:o:75:CYS:C	33:o:76:LYS:HE2	2.17	0.70
43:1:1307:C:O2'	43:1:1308:C:OP1	2.10	0.70
6:D:242:LEU:CD1	6:D:245:MET:HE2	2.21	0.70
35:c:16:LEU:HD13	35:c:20:LEU:HD23	1.74	0.70
42:4:112:C:OP2	43:1:1463:G:N2	2.20	0.70
43:1:1900:G:N7	49:1:2964:HOH:O	2.23	0.70
31:i:44:ALA:HB3	31:i:47:GLU:OE1	1.91	0.70
31:i:48:MET:O	31:i:52:GLU:HG2	1.91	0.70
5:p:6:LYS:HB3	5:p:6:LYS:HZ2	1.56	0.69
43:1:220:A:N6	43:1:247:A:O2'	2.25	0.69
26:F:204:SER:O	26:F:233:ARG:NH2	2.24	0.69
15:S:36:LYS:HG3	15:S:94:ILE:HG23	1.74	0.69
43:1:2403:C:OP2	49:1:2931:HOH:O	2.11	0.69
17:T:50:LYS:NZ	49:T:202:HOH:O	2.24	0.69
10:O:175:ILE:HD12	12:M:127:ALA:HA	1.74	0.69
15:S:127:THR:HG22	15:S:129:ALA:H	1.58	0.69
3:C:268:ASP:N	3:C:268:ASP:OD1	2.24	0.69
23:Z:11:VAL:O	23:Z:81:THR:OG1	2.08	0.69
23:Z:65:ARG:HH11	23:Z:67:ARG:HH12	1.38	0.69
27:d:95:THR:HG22	27:d:96:THR:H	1.58	0.69
32:k:67:LYS:HD3	32:k:67:LYS:N	2.07	0.69
43:1:328:A:N6	43:1:341:G:O2'	2.25	0.69
43:1:2577:C:OP1	49:1:2930:HOH:O	2.10	0.69
15:S:34:MET:HE1	15:S:62:PRO:HD3	1.74	0.69
43:1:61:A:OP2	49:1:2928:HOH:O	2.09	0.69
8:G:134:ILE:HB	8:G:160:ILE:HD13	1.75	0.68
14:Q:113:GLU:OE2	14:Q:113:GLU:HA	1.93	0.68
32:k:57:ALA:O	32:k:61:VAL:HG12	1.94	0.68
43:1:590:G:OP2	49:1:2927:HOH:O	2.09	0.68
30:f:5:LYS:HE2	30:f:5:LYS:HA	1.73	0.68
43:1:450:G:N2	43:1:453:C:OP2	2.27	0.68
16:R:157:GLU:O	16:R:161:GLN:HG3	1.94	0.68

Continued on next page...

Continued from previous page...

Atom-1	Atom-2	Interatomic distance (Å)	Clash overlap (Å)
43:1:917:C:O2'	43:1:984:A:N1	2.26	0.68
9:J:117:ASP:OD2	9:J:120:MET:N	2.27	0.68
26:F:170:LYS:H	26:F:170:LYS:HE2	1.59	0.68
32:k:32:LEU:HA	32:k:35:LYS:NZ	2.09	0.68
7:H:118:LYS:HE3	7:H:120:ARG:CZ	2.24	0.68
43:1:2565:G:O2'	43:1:2566:G:OP1	2.11	0.68
5:p:26:LEU:HD11	39:A:180:LEU:HD22	1.76	0.68
6:D:117:ILE:HD13	6:D:121:ALA:HA	1.75	0.68
42:4:18:U:OP2	49:4:301:HOH:O	2.10	0.68
32:k:21:LYS:HD3	32:k:71:GLN:OE1	1.93	0.67
23:Z:121:GLU:OE1	23:Z:123:ARG:NH1	2.27	0.67
7:H:10:LYS:HD3	7:H:50:THR:HG22	1.76	0.67
30:f:61:ILE:HD13	43:1:374:C:H42	1.57	0.67
17:T:150:ILE:HG13	17:T:151:THR:H	1.58	0.67
43:1:1687:G:N7	49:1:2983:HOH:O	2.27	0.67
43:1:2400:U:OP1	49:1:2933:HOH:O	2.13	0.67
5:p:39:CYS:HB3	5:p:42:CYS:O	1.93	0.67
23:Z:126:TRP:O	23:Z:129:THR:HG22	1.95	0.67
4:I:14:ASN:OD1	49:1:2922:HOH:O	2.11	0.67
9:J:33:ALA:O	9:J:36:VAL:HG22	1.95	0.67
34:U:78:ASN:HB3	34:U:81:GLU:OE1	1.95	0.67
34:U:65:PHE:CE1	34:U:123:LYS:HG2	2.30	0.66
6:D:241:ARG:HH11	6:D:241:ARG:HA	1.59	0.66
13:N:121:VAL:HG11	13:N:131:GLU:HG3	1.76	0.66
30:f:87:LEU:HD11	43:1:374:C:H41	1.59	0.66
43:1:825:G:OP2	49:1:2935:HOH:O	2.13	0.66
42:4:35:C:OP1	49:4:303:HOH:O	2.13	0.66
12:M:115:LEU:HD23	12:M:118:GLU:OE1	1.95	0.66
31:i:28:PRO:O	31:i:31:GLU:HG3	1.94	0.66
43:1:2365:G:O5'	49:1:2932:HOH:O	2.12	0.66
10:O:185:LEU:CD2	12:M:123:MET:HE1	2.25	0.66
3:C:205:ALA:O	3:C:209:ARG:HG3	1.96	0.66
3:C:245:ALA:O	3:C:248:ASP:HB2	1.95	0.66
42:4:105:C:OP2	49:4:302:HOH:O	2.12	0.66
3:C:210:ASN:O	49:C:401:HOH:O	2.14	0.66
4:I:194:GLY:HA3	43:1:722:G:O2'	1.96	0.66
6:D:270:VAL:HA	6:D:273:ALA:CB	2.26	0.66
15:S:102:LYS:HD3	15:S:157:GLU:OE1	1.96	0.66
17:T:33:VAL:O	49:T:201:HOH:O	2.12	0.66
23:Z:33:ASN:OD1	23:Z:34:GLU:N	2.29	0.66
6:D:241:ARG:HH12	6:D:244:ALA:HB3	1.61	0.66

Continued on next page...

Continued from previous page...

Atom-1	Atom-2	Interatomic distance (Å)	Clash overlap (Å)
39:A:234:LYS:HG2	39:A:238:ILE:HG12	1.76	0.66
26:F:59:LYS:HE3	26:F:63:ASN:HD21	1.61	0.65
43:1:1294:C:C2'	43:1:1454:C:H42	2.08	0.65
20:X:90:SER:O	20:X:94:ILE:HG13	1.97	0.65
23:Z:100:ASP:OD1	23:Z:100:ASP:N	2.22	0.65
27:d:1:MET:HE1	27:d:100:GLY:C	2.22	0.65
34:U:148:ASP:HB3	34:U:151:THR:HG22	1.77	0.65
42:4:54:G:N7	49:4:304:HOH:O	2.29	0.65
1:B:10:ARG:O	49:B:501:HOH:O	2.14	0.65
26:F:20:SER:O	26:F:24:ARG:HG3	1.96	0.65
6:D:272:GLN:HG3	41:3:59:C:H4'	1.78	0.65
43:1:2358:G:OP2	49:1:2941:HOH:O	2.14	0.65
1:B:169:PRO:CB	1:B:315:GLY:HA3	2.26	0.65
33:o:76:LYS:HE2	33:o:76:LYS:N	2.12	0.65
43:1:2033:U:OP1	49:1:2934:HOH:O	2.13	0.65
43:1:2280:U:O2'	49:1:2937:HOH:O	2.13	0.65
7:H:16:GLU:OE2	7:H:27:LYS:HE2	1.96	0.65
4:I:47:PRO:O	4:I:178:LYS:NZ	2.30	0.65
13:N:83:LYS:NZ	49:N:301:HOH:O	2.29	0.65
12:M:64:ILE:HA	12:M:76:GLU:OE1	1.97	0.65
26:F:20:SER:HB3	26:F:23:GLU:OE2	1.97	0.65
43:1:1136:G:OP2	49:1:2940:HOH:O	2.14	0.65
15:S:33:MET:HE1	15:S:35:GLN:OE1	1.96	0.65
16:R:93:THR:O	16:R:97:GLN:HG3	1.97	0.65
30:f:12:ALA:HB3	30:f:92:VAL:HG22	1.79	0.65
43:1:1360:A:H62	43:1:1412:A:H2	1.43	0.65
3:C:200:ASN:ND2	3:C:201:THR:HG23	2.12	0.65
3:C:223:ARG:NH2	3:C:226:GLU:OE2	2.30	0.65
25:h:19:ARG:HD2	25:h:23:ASP:OD2	1.97	0.65
34:U:149:LYS:O	34:U:149:LYS:HG2	1.95	0.64
26:F:112:MET:HE1	26:F:122:LEU:HD22	1.79	0.64
2:a:65:ARG:HH21	43:1:96:C:H42	1.44	0.64
16:R:55:ILE:HD12	43:1:1503:U:H5''	1.77	0.64
6:D:5:LYS:HD3	43:1:749:C:H5''	1.78	0.64
6:D:154:LEU:HD21	6:D:156:ILE:HD11	1.80	0.64
9:J:78:GLU:N	9:J:78:GLU:OE1	2.31	0.64
32:k:26:SER:OG	32:k:74:ASN:HA	1.97	0.64
43:1:2626:G:O2'	43:1:2627:C:OP2	2.16	0.64
17:T:83:ARG:NH1	17:T:85:MET:HE3	2.13	0.64
26:F:67:ASN:O	26:F:67:ASN:ND2	2.26	0.64
30:f:42:THR:CG2	30:f:73:GLY:HA2	2.28	0.64

Continued on next page...

Continued from previous page...

Atom-1	Atom-2	Interatomic distance (Å)	Clash overlap (Å)
9:J:28:ASP:HB3	9:J:32:LYS:HE2	1.78	0.64
36:j:78:MET:HE2	42:4:35:C:H1'	1.79	0.64
10:O:73:PRO:HG2	10:O:103:ASP:OD1	1.98	0.64
11:L:225:ALA:O	11:L:229:THR:HG23	1.98	0.64
11:L:226:ALA:HB1	11:L:230:LYS:HZ1	1.62	0.64
43:1:268:A:OP2	49:1:2945:HOH:O	2.16	0.64
7:H:30:LYS:HZ3	7:H:82:TYR:HA	1.63	0.63
29:g:37:LYS:NZ	43:1:1266:G:OP2	2.31	0.63
12:M:58:THR:HG22	12:M:60:GLN:H	1.62	0.63
24:b:52:ARG:O	24:b:52:ARG:HD3	1.97	0.63
30:f:54:HIS:HD2	30:f:57:SER:H	1.44	0.63
8:G:50:ARG:NH1	8:G:216:VAL:O	2.32	0.63
16:R:168:GLN:HG2	16:R:172:GLU:OE2	1.97	0.63
43:1:2095:G:O6	43:1:2096:A:N6	2.31	0.63
26:F:165:ASP:O	26:F:169:SER:HB3	1.99	0.63
41:3:42:A:OP2	49:3:302:HOH:O	2.15	0.63
43:1:2264:C:OP2	43:1:2265:C:N4	2.31	0.63
6:D:141:GLU:OE1	6:D:141:GLU:HA	1.98	0.63
43:1:1293:C:O2'	43:1:1294:C:OP1	2.15	0.63
35:c:20:LEU:HB3	35:c:103:ASP:OD1	1.97	0.63
21:Y:1:MET:N	43:1:177:G:OP2	2.32	0.63
12:M:73:LEU:HD13	12:M:77:ILE:HG13	1.81	0.63
15:S:162:ASP:N	15:S:162:ASP:OD1	2.30	0.63
37:l:50:LYS:NZ	49:l:101:HOH:O	2.25	0.62
26:F:29:GLU:OE1	26:F:29:GLU:HA	1.96	0.62
16:R:158:GLU:HA	16:R:161:GLN:HE21	1.64	0.62
24:b:43:LEU:HD12	24:b:43:LEU:O	1.98	0.62
1:B:121:ASN:ND2	49:B:505:HOH:O	2.32	0.62
3:C:159:ILE:HG23	3:C:164:VAL:CG1	2.29	0.62
9:J:23:ILE:HD12	9:J:23:ILE:O	2.00	0.62
31:i:55:ARG:HG3	31:i:55:ARG:HH11	1.65	0.62
34:U:127:LYS:HG2	34:U:131:LYS:HE2	1.82	0.62
20:X:37:LEU:HD23	20:X:38:VAL:N	2.15	0.62
30:f:2:GLU:CD	30:f:2:GLU:H	2.07	0.62
32:k:5:ILE:HG21	32:k:10:LEU:HD23	1.82	0.62
3:C:275:SER:O	3:C:279:GLN:HG2	1.99	0.62
14:Q:61:VAL:HG12	14:Q:84:THR:CG2	2.29	0.62
6:D:225:TYR:CE2	6:D:233:ILE:HD11	2.35	0.62
3:C:314:MET:HB2	3:C:315:PRO:HD3	1.82	0.62
6:D:191:TYR:HA	6:D:196:PHE:HB2	1.81	0.62
8:G:51:LEU:O	8:G:214:GLY:HA3	2.00	0.62

Continued on next page...

Continued from previous page...

Atom-1	Atom-2	Interatomic distance (Å)	Clash overlap (Å)
25:h:6:ALA:O	25:h:10:ILE:HG23	2.00	0.62
2:a:17:MET:SD	49:a:301:HOH:O	2.56	0.62
3:C:96:THR:HG22	3:C:98:ILE:H	1.65	0.62
4:I:200:ILE:HG23	4:I:202:ARG:HH22	1.65	0.62
23:Z:94:SER:H	23:Z:97:THR:CG2	2.13	0.62
34:U:67:VAL:O	34:U:111:SER:HB3	2.00	0.62
9:J:35:LYS:HD3	9:J:35:LYS:C	2.25	0.62
13:N:176:ASN:O	13:N:185:ARG:NH2	2.33	0.61
20:X:90:SER:N	20:X:93:GLU:OE2	2.30	0.61
43:1:215:C:H2'	43:1:216:G:C8	2.35	0.61
27:d:47:ASP:O	27:d:50:VAL:HG13	2.00	0.61
34:U:141:VAL:HG22	34:U:142:PHE:CD1	2.35	0.61
3:C:181:ARG:NH1	3:C:184:MET:SD	2.73	0.61
6:D:121:ALA:HB3	6:D:124:GLN:NE2	2.15	0.61
6:D:226:ARG:HG2	6:D:226:ARG:HH11	1.64	0.61
17:T:144:ILE:HD11	26:F:70:LEU:HG	1.82	0.61
30:f:66:CYS:SG	30:f:78:ARG:HG3	2.41	0.61
43:1:1982:C:O2'	43:1:1983:C:O4'	2.19	0.61
14:Q:109:ARG:O	14:Q:113:GLU:HG2	2.01	0.61
1:B:186:ALA:N	1:B:190:GLU:OE1	2.27	0.61
9:J:161:ALA:O	9:J:164:GLU:HG3	2.01	0.61
34:U:93:ASN:ND2	34:U:93:ASN:O	2.34	0.61
10:O:174:LYS:O	10:O:177:GLU:HG2	2.01	0.61
14:Q:13:LYS:HE2	43:1:814:G:O6	2.00	0.61
7:H:1:MET:HG3	7:H:2:PRO:HD2	1.83	0.61
42:4:118:G:O2'	42:4:119:G:O5'	2.18	0.61
43:1:347:A:H4'	43:1:348:A:OP1	2.01	0.61
4:I:1:MET:CE	4:I:3:ARG:HB3	2.31	0.60
4:I:144:ALA:O	4:I:148:VAL:HG23	2.01	0.60
6:D:133:THR:O	6:D:198:SER:OG	2.19	0.60
11:L:157:LYS:H	11:L:157:LYS:HD2	1.66	0.60
21:Y:33:ARG:HH21	21:Y:45:LYS:HD3	1.66	0.60
24:b:5:LYS:HG2	49:1:4169:HOH:O	1.99	0.60
30:f:61:ILE:CD1	43:1:374:C:H42	2.15	0.60
6:D:277:LEU:O	6:D:283:ARG:NH2	2.33	0.60
32:k:21:LYS:O	32:k:40:LEU:HD12	2.02	0.60
43:1:334:U:O2'	43:1:335:G:OP1	2.18	0.60
41:3:75:G:O2'	41:3:76:U:OP2	2.18	0.60
1:B:57:MET:HE1	22:W:1:MET:HE2	1.82	0.60
43:1:743:C:O2'	43:1:744:U:O5'	2.09	0.60
3:C:104:LYS:HA	43:1:427:C:H5	1.66	0.60

Continued on next page...

Continued from previous page...

Atom-1	Atom-2	Interatomic distance (Å)	Clash overlap (Å)
8:G:67:ASN:O	8:G:71:GLU:HG2	2.02	0.60
35:c:48:MET:HG2	35:c:93:ILE:HD13	1.83	0.60
43:1:2685:C:H3'	43:1:2686:G:H21	1.66	0.60
15:S:56:ARG:HD2	17:T:148:ILE:HD11	1.83	0.60
21:Y:57:ILE:HD13	21:Y:104:CYS:HB3	1.83	0.60
28:e:94:ASN:ND2	28:e:121:GLY:O	2.34	0.60
43:1:163:A:H8	43:1:183:G:HO2'	1.50	0.60
16:R:151:LEU:HD22	16:R:151:LEU:O	2.02	0.60
20:X:136:SER:HA	20:X:141:ALA:HB3	1.82	0.60
43:1:2292:G:O6	49:1:2936:HOH:O	2.13	0.60
13:N:65:ARG:HD3	13:N:127:TYR:CD1	2.36	0.60
23:Z:49:ARG:HG3	23:Z:50:ARG:H	1.66	0.60
34:U:145:LEU:O	34:U:153:THR:HG22	2.02	0.60
7:H:137:LYS:HG3	7:H:138:ASP:N	2.17	0.60
28:e:9:LEU:HD12	28:e:96:THR:HG23	1.84	0.60
34:U:78:ASN:HB3	34:U:81:GLU:CD	2.27	0.60
37:l:13:LEU:HD13	49:1:5049:HOH:O	2.02	0.60
5:p:16:THR:HG22	43:1:1557:G:C8	2.37	0.59
27:d:6:GLU:OE2	27:d:86:LYS:HE3	2.02	0.59
6:D:285:ASP:O	6:D:289:LEU:HD23	2.02	0.59
23:Z:28:GLU:OE1	23:Z:30:LEU:HD13	2.02	0.59
6:D:288:LYS:HE2	6:D:288:LYS:N	2.18	0.59
8:G:103:PRO:HA	8:G:106:GLU:OE1	2.02	0.59
24:b:5:LYS:HA	49:1:4169:HOH:O	2.01	0.59
11:L:188:SER:HB3	11:L:191:GLU:HG2	1.84	0.59
12:M:123:MET:CA	12:M:123:MET:HE2	2.32	0.59
16:R:151:LEU:O	16:R:151:LEU:HD13	2.03	0.59
24:b:45:ARG:HD3	43:1:785:G:C4	2.37	0.59
32:k:28:SER:HA	32:k:34:GLY:H	1.68	0.59
6:D:108:ARG:NH1	6:D:259:ALA:HB2	2.18	0.59
11:L:226:ALA:HB1	11:L:230:LYS:NZ	2.17	0.59
14:Q:45:THR:O	14:Q:49:THR:HG23	2.03	0.59
12:M:17:ASP:OD1	12:M:18:GLY:N	2.36	0.59
23:Z:100:ASP:OD2	23:Z:103:LYS:HG3	2.03	0.59
4:I:184:LEU:HB3	4:I:190:LEU:HD13	1.84	0.58
8:G:220:ASP:HB3	8:G:221:GLU:OE1	2.03	0.58
9:J:165:ARG:O	9:J:165:ARG:HG2	2.02	0.58
17:T:26:ASN:O	17:T:29:THR:HG23	2.02	0.58
20:X:133:ASP:OD1	20:X:134:VAL:N	2.36	0.58
23:Z:117:ARG:HB3	23:Z:117:ARG:CZ	2.32	0.58
26:F:50:TYR:O	26:F:54:VAL:HG23	2.03	0.58

Continued on next page...

Continued from previous page...

Atom-1	Atom-2	Interatomic distance (Å)	Clash overlap (Å)
32:k:69:GLU:CD	32:k:71:GLN:HE22	2.10	0.58
8:G:103:PRO:O	8:G:106:GLU:HB2	2.03	0.58
9:J:28:ASP:CG	9:J:32:LYS:HE2	2.28	0.58
31:i:85:VAL:O	31:i:89:ASN:HB3	2.03	0.58
43:1:327:G:O2'	43:1:328:A:OP2	2.15	0.58
23:Z:65:ARG:NH1	23:Z:67:ARG:HH12	2.01	0.58
29:g:78:LEU:HD11	29:g:83:LEU:HB2	1.84	0.58
34:U:141:VAL:O	34:U:142:PHE:HB2	2.03	0.58
5:p:83:ILE:CD1	39:A:111:THR:HG23	2.33	0.58
6:D:92:LEU:O	6:D:93:THR:OG1	2.17	0.58
11:L:136:GLU:H	11:L:136:GLU:CD	2.11	0.58
35:c:100:GLY:H	35:c:103:ASP:CG	2.10	0.58
36:j:13:SER:HB2	43:1:1626:C:H5	1.69	0.58
23:Z:58:GLU:OE1	23:Z:58:GLU:HA	2.02	0.58
3:C:130:ARG:HD3	3:C:234:GLY:O	2.03	0.58
21:Y:50:ARG:HG2	21:Y:51:ARG:N	2.19	0.58
30:f:5:LYS:HE2	30:f:5:LYS:CA	2.33	0.58
36:j:50:TYR:CD2	36:j:51:PRO:HA	2.38	0.58
43:1:1380:C:H4'	43:1:1381:G:O5'	2.04	0.58
43:1:1906:C:HO2'	43:1:1907:U:H6	1.51	0.58
1:B:298:PHE:CG	22:W:1:MET:HE1	2.39	0.58
3:C:41:ARG:NH2	43:1:1066:A:O2'	2.36	0.58
6:D:271:ARG:NH1	41:3:20:G:H21	2.02	0.58
12:M:58:THR:HG22	12:M:59:ASP:N	2.19	0.58
34:U:105:CYS:SG	34:U:114:ILE:HG12	2.44	0.58
17:T:2:THR:N	43:1:2054:G:O6	2.37	0.58
39:A:215:ASN:ND2	43:1:2389:A:N7	2.52	0.58
4:I:1:MET:HE1	4:I:3:ARG:HB3	1.86	0.57
7:H:1:MET:HE2	7:H:4:CYS:H	1.68	0.57
10:O:171:ILE:HG23	12:M:131:LYS:O	2.04	0.57
13:N:188:LYS:HD3	43:1:47:G:O6	2.04	0.57
8:G:50:ARG:NH1	8:G:50:ARG:HB3	2.19	0.57
24:b:10:LYS:HE2	49:1:4606:HOH:O	2.02	0.57
26:F:59:LYS:HE3	26:F:63:ASN:ND2	2.18	0.57
7:H:7:MET:HE1	7:H:67:ARG:HD2	1.86	0.57
9:J:28:ASP:CB	9:J:32:LYS:HE2	2.34	0.57
20:X:132:MET:HE1	20:X:141:ALA:HB2	1.87	0.57
6:D:270:VAL:HA	6:D:273:ALA:HB3	1.85	0.57
17:T:79:ARG:HD3	17:T:81:ARG:O	2.03	0.57
6:D:226:ARG:HG2	6:D:226:ARG:NH1	2.20	0.57
7:H:82:TYR:HE1	7:H:182:LEU:HD13	1.69	0.57

Continued on next page...

Continued from previous page...

Atom-1	Atom-2	Interatomic distance (Å)	Clash overlap (Å)
13:N:177:LYS:HG3	13:N:185:ARG:NH2	2.20	0.57
26:F:48:ARG:HB2	26:F:48:ARG:HH11	1.70	0.57
9:J:23:ILE:HD11	9:J:30:LEU:HD22	1.86	0.57
43:1:1414:C:O2'	43:1:1415:C:P	2.63	0.57
43:1:2010:C:O2'	43:1:2011:G:OP2	2.21	0.57
6:D:270:VAL:CG2	6:D:273:ALA:HB3	2.33	0.57
17:T:48:TYR:O	17:T:52:MET:HE3	2.05	0.57
20:X:132:MET:CE	20:X:141:ALA:HB2	2.35	0.57
13:N:128:LYS:NZ	49:N:302:HOH:O	2.38	0.56
15:S:33:MET:HE3	15:S:33:MET:C	2.29	0.56
23:Z:66:VAL:HG21	23:Z:119:ILE:HD12	1.87	0.56
25:h:19:ARG:HB3	25:h:19:ARG:CZ	2.34	0.56
35:c:14:ILE:HG22	35:c:107:ILE:CG2	2.35	0.56
7:H:133:SER:CB	7:H:139:GLU:HB3	2.35	0.56
9:J:25:GLY:O	9:J:30:LEU:HD23	2.05	0.56
9:J:108:GLU:OE2	9:J:111:ASP:HB3	2.05	0.56
3:C:26:VAL:HG13	3:C:27:PRO:HD2	1.85	0.56
6:D:59:ASP:HA	6:D:93:THR:HG22	1.87	0.56
6:D:136:GLU:OE1	6:D:185:MET:HG3	2.05	0.56
21:Y:59:THR:HG22	21:Y:103:ASN:HB2	1.88	0.56
30:f:1:MET:HE2	30:f:58:GLY:O	2.04	0.56
34:U:102:LYS:O	34:U:116:THR:HG23	2.04	0.56
1:B:169:PRO:HB3	1:B:315:GLY:HA3	1.87	0.56
12:M:68:PRO:HG2	12:M:73:LEU:HD23	1.86	0.56
19:P:49:ASN:HB3	19:P:55:GLU:HG3	1.85	0.56
21:Y:39:ARG:HD2	21:Y:44:ILE:O	2.06	0.56
32:k:58:LYS:HE2	32:k:58:LYS:H	1.70	0.56
43:1:389:C:OP2	49:1:2946:HOH:O	2.18	0.56
8:G:188:ASP:O	8:G:191:THR:HG23	2.05	0.56
10:O:127:ARG:NE	10:O:129:GLU:OE2	2.39	0.56
14:Q:84:THR:HG21	43:1:422:G:O6	2.06	0.56
15:S:153:ILE:O	17:T:150:ILE:HD11	2.06	0.56
34:U:153:THR:O	34:U:154:LEU:HD23	2.06	0.56
43:1:427:C:OP1	49:1:2947:HOH:O	2.18	0.56
6:D:119:GLU:OE2	6:D:119:GLU:HA	2.04	0.56
7:H:30:LYS:NZ	7:H:82:TYR:HA	2.21	0.56
35:c:100:GLY:N	35:c:103:ASP:OD2	2.37	0.56
43:1:254:G:OP1	49:1:2948:HOH:O	2.18	0.56
6:D:281:LYS:HD2	41:3:107:G:H5''	1.88	0.56
25:h:7:LYS:HE2	42:4:66:G:OP1	2.05	0.56
43:1:2176:G:H4'	43:1:2177:C:OP2	2.06	0.56

Continued on next page...

Continued from previous page...

Atom-1	Atom-2	Interatomic distance (Å)	Clash overlap (Å)
15:S:36:LYS:CG	15:S:94:ILE:HG23	2.36	0.56
17:T:136:PRO:HB2	26:F:75:GLU:HB2	1.87	0.56
18:V:69:ASP:OD1	18:V:69:ASP:N	2.36	0.56
20:X:66:ILE:HG22	20:X:71:ASN:ND2	2.20	0.56
26:F:63:ASN:O	26:F:66:LYS:HG2	2.05	0.56
43:1:2098:G:N3	43:1:2099:G:N1	2.53	0.56
3:C:313:VAL:HG12	3:C:315:PRO:HD2	1.87	0.56
9:J:26:GLU:CG	9:J:64:LYS:HB2	2.36	0.56
30:f:38:THR:HG22	30:f:40:ALA:H	1.71	0.56
43:1:1728:A:OP2	49:1:2950:HOH:O	2.18	0.56
6:D:286:ALA:O	6:D:289:LEU:HG	2.06	0.55
43:1:1365:C:O2'	43:1:1366:C:OP1	2.21	0.55
30:f:38:THR:HB	30:f:41:GLU:HG3	1.88	0.55
39:A:5:ILE:HG22	39:A:6:ARG:N	2.21	0.55
15:S:42:ARG:HG2	15:S:43:ARG:O	2.06	0.55
18:V:114:LEU:HD11	18:V:119:ILE:HD11	1.87	0.55
19:P:58:PRO:O	49:P:301:HOH:O	2.18	0.55
6:D:289:LEU:O	6:D:293:LYS:HG2	2.07	0.55
32:k:42:THR:HG22	32:k:45:TYR:H	1.70	0.55
1:B:247:ARG:NH2	43:1:1827:A:OP2	2.40	0.55
12:M:73:LEU:HD13	12:M:73:LEU:O	2.06	0.55
17:T:104:ASN:O	17:T:107:GLU:HG2	2.07	0.55
8:G:88:LYS:O	8:G:92:LEU:HD12	2.07	0.55
12:M:66:GLU:HG2	12:M:67:LYS:HG3	1.89	0.55
15:S:153:ILE:HG23	17:T:151:THR:O	2.07	0.55
35:c:103:ASP:OD1	35:c:103:ASP:N	2.38	0.55
24:b:41:ARG:O	24:b:45:ARG:HG3	2.07	0.55
43:1:340:C:H2'	43:1:341:G:O4'	2.07	0.55
6:D:6:VAL:HG12	6:D:9:THR:HG22	1.89	0.55
6:D:214:MET:CE	6:D:239:PRO:HD3	2.37	0.55
37:l:29:LEU:HD12	37:l:29:LEU:C	2.32	0.55
4:I:169:ARG:HG3	4:I:169:ARG:NH1	2.19	0.55
6:D:290:GLU:OE1	6:D:291:ALA:N	2.40	0.55
29:g:65:ARG:NH2	43:1:1455:G:OP1	2.39	0.55
30:f:40:ALA:O	30:f:43:ASP:HB2	2.07	0.55
35:c:14:ILE:HG22	35:c:107:ILE:HG21	1.89	0.55
27:d:8:THR:HG22	27:d:67:ARG:HH11	1.72	0.55
35:c:20:LEU:HD12	35:c:102:ALA:HB3	1.89	0.55
7:H:88:MET:HB2	7:H:140:LEU:HB2	1.89	0.54
23:Z:30:LEU:HD22	23:Z:30:LEU:H	1.72	0.54
7:H:82:TYR:CE1	7:H:182:LEU:HD13	2.43	0.54

Continued on next page...

Continued from previous page...

Atom-1	Atom-2	Interatomic distance (Å)	Clash overlap (Å)
9:J:36:VAL:HG13	9:J:120:MET:HE3	1.89	0.54
32:k:37:LYS:HG2	32:k:50:THR:OG1	2.07	0.54
43:1:1235:G:O2'	43:1:1236:G:OP2	2.20	0.54
12:M:123:MET:HE2	12:M:123:MET:N	2.23	0.54
43:1:839:G:H4'	49:1:4687:HOH:O	2.07	0.54
5:p:4:ARG:NH2	43:1:553:G:O6	2.40	0.54
6:D:220:GLU:OE1	6:D:221:ASP:N	2.41	0.54
11:L:157:LYS:HD2	11:L:157:LYS:N	2.21	0.54
11:L:165:GLN:N	11:L:165:GLN:OE1	2.40	0.54
28:e:131:LEU:O	28:e:132:ARG:HD3	2.06	0.54
31:i:16:ARG:HG3	31:i:17:ILE:N	2.22	0.54
26:F:76:PRO:HB3	26:F:133:GLU:HG2	1.89	0.54
42:4:34:G:N3	42:4:34:G:H2'	2.22	0.54
31:i:48:MET:HE3	31:i:48:MET:HA	1.89	0.54
35:c:40:ASP:HB3	35:c:42:LYS:CD	2.38	0.54
36:j:75:MET:HG2	36:j:78:MET:HB2	1.90	0.54
6:D:238:GLU:OE1	6:D:238:GLU:N	2.37	0.54
20:X:69:ASP:HA	20:X:72:THR:HG22	1.88	0.54
22:W:13:LYS:HB3	22:W:13:LYS:HZ2	1.72	0.54
23:Z:104:ARG:O	23:Z:108:ILE:HG12	2.08	0.54
26:F:65:LEU:O	26:F:65:LEU:HD13	2.06	0.54
33:o:6:ALA:HB2	33:o:92:SER:O	2.08	0.54
9:J:29:ALA:HA	9:J:123:TYR:OH	2.07	0.54
16:R:47:SER:O	16:R:48:LYS:HB2	2.07	0.54
23:Z:47:LEU:HB3	23:Z:48:PRO:CD	2.38	0.54
9:J:155:THR:HG23	9:J:158:GLU:OE2	2.08	0.54
4:I:102:MET:HE1	4:I:113:THR:O	2.07	0.54
11:L:160:LYS:HB3	11:L:162:GLU:CD	2.33	0.54
15:S:46:SER:OG	15:S:47:GLU:N	2.41	0.54
34:U:78:ASN:HB3	34:U:81:GLU:OE2	2.07	0.54
42:4:16:G:O2'	42:4:17:A:O5'	2.25	0.54
6:D:224:THR:HA	6:D:227:LYS:HG2	1.89	0.53
7:H:161:LEU:HD12	7:H:175:CYS:SG	2.48	0.53
10:O:10:GLY:HA2	10:O:39:ILE:HD12	1.89	0.53
15:S:76:LYS:HG3	15:S:82:LYS:HG2	1.89	0.53
33:o:10:THR:HG22	33:o:11:PHE:N	2.23	0.53
38:m:113:CYS:O	38:m:114:ARG:HB2	2.08	0.53
41:3:75:G:O2'	41:3:76:U:P	2.66	0.53
1:B:186:ALA:HB3	1:B:190:GLU:OE2	2.08	0.53
14:Q:51:ARG:HH21	14:Q:137:LEU:HD22	1.73	0.53
21:Y:126:ASN:O	21:Y:130:LEU:HG	2.08	0.53

Continued on next page...

Continued from previous page...

Atom-1	Atom-2	Interatomic distance (Å)	Clash overlap (Å)
35:c:87:ARG:HH11	35:c:87:ARG:CG	2.21	0.53
37:l:17:ILE:HG13	49:l:105:HOH:O	2.08	0.53
43:1:1365:C:HO2'	43:1:1366:C:P	2.31	0.53
8:G:201:HIS:C	8:G:201:HIS:HD1	2.17	0.53
16:R:82:ARG:HB3	16:R:82:ARG:HH11	1.71	0.53
20:X:54:SER:OG	20:X:55:TRP:N	2.39	0.53
39:A:210:PRO:HG2	39:A:235:VAL:HG21	1.90	0.53
6:D:90:VAL:HG22	6:D:91:GLY:H	1.74	0.53
23:Z:48:PRO:HG3	23:Z:119:ILE:HD13	1.91	0.53
26:F:81:VAL:HG22	26:F:103:LEU:HD11	1.91	0.53
32:k:42:THR:HG23	32:k:43:ALA:N	2.24	0.53
27:d:87:ASP:N	27:d:87:ASP:OD1	2.41	0.53
10:O:175:ILE:CD1	12:M:127:ALA:HA	2.37	0.53
26:F:23:GLU:N	26:F:23:GLU:OE1	2.37	0.53
16:R:173:ARG:NH2	16:R:176:LYS:HD2	2.24	0.53
3:C:134:ILE:HD12	3:C:134:ILE:C	2.34	0.53
9:J:26:GLU:HG3	9:J:63:GLN:OE1	2.09	0.53
15:S:144:ARG:NH1	43:1:993:G:O2'	2.39	0.53
11:L:57:GLN:HB3	11:L:58:PRO:HD3	1.90	0.53
32:k:38:LEU:O	32:k:48:THR:HA	2.08	0.53
34:U:141:VAL:HG13	34:U:142:PHE:CD1	2.44	0.53
35:c:62:TYR:O	35:c:66:LEU:HD13	2.09	0.53
39:A:179:LEU:O	39:A:180:LEU:HB3	2.08	0.53
6:D:220:GLU:OE1	6:D:221:ASP:HB2	2.09	0.52
9:J:65:ILE:HD11	43:1:2103:C:C5'	2.37	0.52
16:R:63:ILE:HG13	49:R:1502:HOH:O	2.09	0.52
8:G:50:ARG:HB3	8:G:50:ARG:HH11	1.74	0.52
8:G:68:LEU:O	8:G:72:ILE:HG13	2.08	0.52
9:J:162:TRP:O	9:J:166:GLU:HB2	2.08	0.52
16:R:172:GLU:O	16:R:175:GLU:HG3	2.10	0.52
19:P:153:LYS:HD2	19:P:154:PRO:HD2	1.91	0.52
26:F:22:ALA:O	26:F:26:THR:HG23	2.10	0.52
43:1:248:A:O3'	43:1:249:G:H4'	2.08	0.52
4:I:66:GLU:OE1	4:I:66:GLU:HA	2.08	0.52
8:G:90:ARG:HG3	8:G:94:ILE:CG1	2.39	0.52
9:J:110:ILE:HD11	9:J:122:ILE:HG22	1.91	0.52
4:I:187:ARG:NE	4:I:189:GLU:OE2	2.40	0.52
6:D:277:LEU:C	6:D:283:ARG:HE	2.17	0.52
23:Z:117:ARG:NH1	23:Z:117:ARG:CB	2.71	0.52
24:b:37:PRO:O	24:b:41:ARG:HG3	2.09	0.52
34:U:63:ILE:HG13	34:U:120:GLU:OE1	2.09	0.52

Continued on next page...

Continued from previous page...

Atom-1	Atom-2	Interatomic distance (Å)	Clash overlap (Å)
34:U:93:ASN:C	34:U:93:ASN:HD22	2.16	0.52
7:H:1:MET:HE2	7:H:3:LEU:HB3	1.92	0.52
7:H:129:THR:O	7:H:142:LEU:HA	2.09	0.52
15:S:114:VAL:HG12	15:S:114:VAL:O	2.10	0.52
15:S:132:MET:HE1	15:S:152:ILE:HD12	1.91	0.52
43:1:334:U:C2'	43:1:335:G:OP1	2.57	0.52
7:H:64:ALA:O	7:H:68:THR:HG23	2.09	0.52
26:F:130:THR:OG1	26:F:223:ARG:HD2	2.09	0.52
43:1:897:G:O2'	43:1:1007:G:N2	2.43	0.52
7:H:15:VAL:HG23	7:H:81:THR:HG22	1.90	0.52
8:G:163:THR:HG22	8:G:165:GLY:N	2.23	0.52
13:N:3:ALA:O	13:N:7:VAL:HG23	2.10	0.52
29:g:78:LEU:HD12	29:g:79:CYS:O	2.10	0.52
6:D:116:GLY:O	6:D:118:LYS:HE2	2.10	0.52
14:Q:75:GLU:N	14:Q:75:GLU:OE1	2.43	0.52
9:J:44:GLU:CD	9:J:44:GLU:H	2.18	0.52
26:F:85:ARG:HG2	26:F:128:TYR:CE2	2.45	0.52
30:f:61:ILE:HD11	43:1:374:C:N3	2.25	0.52
4:I:50:PHE:HZ	4:I:145:LYS:HG3	1.75	0.51
4:I:189:GLU:O	4:I:190:LEU:HD12	2.10	0.51
12:M:108:ASP:OD1	12:M:108:ASP:N	2.29	0.51
29:g:65:ARG:HD2	43:1:1309:G:H5'	1.91	0.51
32:k:36:VAL:HG22	32:k:51:VAL:HG22	1.91	0.51
38:m:94:MET:HE3	38:m:119:ARG:O	2.10	0.51
43:1:2565:G:O2'	43:1:2566:G:P	2.68	0.51
4:I:183:ASP:OD1	4:I:187:ARG:HD3	2.09	0.51
9:J:32:LYS:O	9:J:36:VAL:HG13	2.10	0.51
9:J:155:THR:OG1	9:J:158:GLU:HG3	2.10	0.51
12:M:6:PHE:H	12:M:11:ARG:NH2	2.08	0.51
37:l:46:ARG:HB2	37:l:46:ARG:CZ	2.39	0.51
4:I:30:LYS:HE2	4:I:66:GLU:CB	2.41	0.51
11:L:95:ASN:OD1	43:1:70:C:O2'	2.28	0.51
16:R:92:LYS:NZ	43:1:572:G:OP2	2.43	0.51
16:R:109:TYR:CE2	16:R:114:LYS:HD2	2.44	0.51
43:1:1427:G:H2'	43:1:1428:G:C8	2.45	0.51
4:I:184:LEU:HB3	4:I:190:LEU:CD1	2.41	0.51
8:G:146:TRP:O	8:G:149:THR:HG23	2.11	0.51
9:J:28:ASP:HA	9:J:31:THR:HB	1.91	0.51
12:M:28:VAL:HG22	12:M:37:LEU:O	2.11	0.51
14:Q:174:ARG:HB2	14:Q:178:SER:OG	2.10	0.51
19:P:10:ASN:HD21	19:P:152:PRO:CD	2.23	0.51

Continued on next page...

Continued from previous page...

Atom-1	Atom-2	Interatomic distance (Å)	Clash overlap (Å)
27:d:3:ILE:HD12	27:d:99:LYS:O	2.10	0.51
4:I:183:ASP:OD1	4:I:183:ASP:C	2.53	0.51
6:D:242:LEU:HD11	6:D:245:MET:HE2	1.91	0.51
7:H:65:LEU:O	7:H:69:ILE:HG12	2.10	0.51
8:G:140:PRO:HG3	13:N:43:THR:O	2.11	0.51
23:Z:91:ASP:OD1	23:Z:92:PHE:HD1	1.93	0.51
30:f:42:THR:HG21	30:f:73:GLY:HA2	1.93	0.51
1:B:74:ASP:OD2	1:B:325:LYS:HG3	2.11	0.51
14:Q:1:MET:HB3	43:1:868:C:OP1	2.11	0.51
14:Q:124:GLU:O	14:Q:128:GLU:HG3	2.11	0.51
37:l:8:GLU:OE1	42:4:110:C:OP2	2.29	0.51
43:1:1014:G:HO2'	43:1:1015:G:P	2.32	0.51
1:B:238:LEU:HB2	1:B:246:ASN:HB2	1.93	0.51
3:C:230:GLY:O	3:C:231:SER:HB3	2.11	0.51
3:C:245:ALA:HA	3:C:248:ASP:OD2	2.11	0.51
10:O:111:ARG:HD2	43:1:2572:C:C5	2.45	0.51
17:T:150:ILE:HG13	17:T:151:THR:N	2.25	0.51
28:e:13:ILE:O	28:e:13:ILE:HG13	2.09	0.51
34:U:69:CYS:HA	34:U:154:LEU:HD12	1.91	0.51
4:I:84:SER:HA	4:I:141:ARG:NH1	2.25	0.51
5:p:3:LYS:HE3	43:1:567:U:C4	2.46	0.51
22:W:54:LEU:HD11	22:W:63:GLU:HG2	1.93	0.51
43:1:2407:A:OP2	49:1:2952:HOH:O	2.20	0.51
1:B:172:GLN:NE2	1:B:174:LYS:O	2.39	0.51
6:D:79:TYR:HB2	6:D:82:GLU:OE1	2.11	0.51
12:M:8:GLU:OE2	12:M:11:ARG:NH2	2.44	0.51
34:U:77:LEU:CD1	34:U:133:PHE:HE2	2.24	0.51
36:j:28:GLY:O	36:j:36:HIS:HA	2.11	0.51
27:d:95:THR:HG22	27:d:96:THR:N	2.26	0.50
29:g:59:ILE:HD11	29:g:62:HIS:CD2	2.46	0.50
34:U:76:GLU:OE1	34:U:76:GLU:N	2.44	0.50
43:1:1535:G:OP2	49:1:2951:HOH:O	2.19	0.50
3:C:4:THR:OG1	3:C:17:GLU:OE2	2.27	0.50
3:C:193:LYS:HE3	43:1:1068:G:OP1	2.11	0.50
23:Z:118:ARG:HG3	23:Z:123:ARG:NH2	2.27	0.50
35:c:21:VAL:HA	35:c:103:ASP:OD2	2.10	0.50
43:1:631:G:H5'	43:1:632:A:OP1	2.11	0.50
43:1:888:C:O2'	43:1:889:C:O5'	2.28	0.50
1:B:59:PHE:HB2	1:B:354:GLN:NE2	2.26	0.50
1:B:362:PHE:O	43:1:2636:C:H4'	2.12	0.50
35:c:48:MET:CE	35:c:57:LYS:HG2	2.27	0.50

Continued on next page...

Continued from previous page...

Atom-1	Atom-2	Interatomic distance (Å)	Clash overlap (Å)
42:4:16:G:O2'	42:4:17:A:H8	1.95	0.50
5:p:41:PHE:CD2	5:p:62:LYS:HD2	2.47	0.50
9:J:117:ASP:OD2	9:J:120:MET:HB2	2.11	0.50
10:O:165:TYR:O	10:O:169:ILE:HG13	2.11	0.50
35:c:48:MET:HG2	35:c:93:ILE:CD1	2.40	0.50
39:A:242:ARG:NH2	39:A:246:SER:HB3	2.26	0.50
35:c:81:LEU:O	35:c:85:VAL:HG22	2.12	0.50
43:1:1014:G:O2'	43:1:1015:G:OP2	2.27	0.50
4:I:200:ILE:CG2	4:I:202:ARG:HH22	2.24	0.50
18:V:76:ARG:NH1	43:1:1781:A:OP2	2.44	0.50
21:Y:125:ARG:HD2	43:1:150:G:O2'	2.11	0.50
29:g:9:ARG:O	29:g:9:ARG:HG3	2.11	0.50
4:I:183:ASP:HA	4:I:186:GLU:HG2	1.93	0.50
6:D:270:VAL:HA	6:D:273:ALA:HB2	1.91	0.50
18:V:108:ILE:HD11	18:V:112:GLY:HA2	1.93	0.50
23:Z:102:THR:O	23:Z:106:GLU:HG3	2.11	0.50
27:d:24:ALA:HB3	27:d:25:PRO:HD3	1.94	0.50
1:B:250:ALA:HB1	43:1:2367:G:C2	2.47	0.50
3:C:159:ILE:HG23	3:C:164:VAL:HG13	1.93	0.50
8:G:127:LYS:HB3	8:G:127:LYS:NZ	2.27	0.50
20:X:115:PRO:HG3	43:1:1204:U:C4	2.47	0.50
35:c:30:GLY:HA3	43:1:1393:G:O6	2.12	0.50
37:l:36:ARG:HD2	37:l:36:ARG:C	2.37	0.50
43:1:1906:C:O2'	43:1:1907:U:H6	1.94	0.50
6:D:144:ASN:HB3	6:D:147:VAL:O	2.11	0.50
7:H:65:LEU:N	7:H:66:PRO:HD2	2.26	0.50
8:G:116:GLY:O	8:G:120:ILE:HG12	2.11	0.50
20:X:125:LEU:HD12	20:X:131:ALA:HA	1.93	0.50
32:k:32:LEU:HA	32:k:35:LYS:HZ1	1.75	0.50
35:c:16:LEU:HD13	35:c:16:LEU:C	2.37	0.50
2:a:91:LEU:HD11	14:Q:92:VAL:HG11	1.94	0.49
6:D:107:ARG:HD2	6:D:177:ALA:HB1	1.93	0.49
11:L:160:LYS:HB3	11:L:162:GLU:OE1	2.12	0.49
21:Y:37:GLU:H	21:Y:37:GLU:CD	2.16	0.49
28:e:55:ARG:HB2	28:e:56:PRO:HD2	1.94	0.49
33:o:59:LYS:HE2	43:1:2216:U:OP1	2.13	0.49
39:A:83:TYR:CZ	39:A:86:GLN:HB2	2.47	0.49
2:a:119:PRO:O	2:a:141:VAL:HG21	2.11	0.49
16:R:55:ILE:HG23	43:1:1503:U:H5'	1.94	0.49
17:T:83:ARG:CZ	17:T:85:MET:HE3	2.42	0.49
20:X:37:LEU:HD23	20:X:37:LEU:C	2.37	0.49

Continued on next page...

Continued from previous page...

Atom-1	Atom-2	Interatomic distance (Å)	Clash overlap (Å)
23:Z:73:MET:SD	23:Z:78:LEU:HD21	2.52	0.49
32:k:18:ARG:HG3	32:k:18:ARG:HH11	1.76	0.49
34:U:97:HIS:C	34:U:97:HIS:HD1	2.20	0.49
6:D:271:ARG:HG3	6:D:272:GLN:N	2.27	0.49
15:S:132:MET:HE3	15:S:132:MET:HA	1.92	0.49
34:U:82:PHE:CD1	34:U:112:LEU:HD22	2.48	0.49
41:3:110:G:H2'	41:3:111:C:C6	2.47	0.49
42:4:105:C:O2	42:4:105:C:O4'	2.27	0.49
43:1:1453:C:H2'	43:1:1454:C:C5	2.47	0.49
3:C:310:SER:OG	3:C:312:THR:HG23	2.12	0.49
6:D:140:ASP:HA	6:D:143:GLU:OE2	2.12	0.49
7:H:1:MET:HE2	7:H:4:CYS:N	2.26	0.49
14:Q:90:ARG:HD2	43:1:500:G:C6	2.48	0.49
23:Z:94:SER:N	23:Z:97:THR:HG22	2.24	0.49
32:k:33:GLN:O	32:k:35:LYS:HG3	2.12	0.49
10:O:156:ARG:O	10:O:159:GLU:HG2	2.13	0.49
20:X:60:ASP:OD1	20:X:60:ASP:C	2.54	0.49
39:A:30:ARG:NH1	39:A:36:GLU:OE1	2.43	0.49
1:B:10:ARG:HB2	1:B:10:ARG:CZ	2.42	0.49
7:H:18:THR:HG23	7:H:25:THR:HB	1.95	0.49
8:G:63:PRO:HG2	8:G:162:ARG:NH1	2.27	0.49
13:N:2:GLY:N	49:N:305:HOH:O	2.45	0.49
23:Z:49:ARG:HG3	23:Z:50:ARG:N	2.27	0.49
27:d:57:ARG:HB2	27:d:61:HIS:O	2.12	0.49
13:N:188:LYS:HD3	43:1:47:G:C6	2.48	0.49
14:Q:113:GLU:OE2	14:Q:113:GLU:CA	2.61	0.49
23:Z:30:LEU:HD22	23:Z:30:LEU:N	2.28	0.49
42:4:112:C:P	43:1:1463:G:H22	2.33	0.49
2:a:85:GLU:H	2:a:85:GLU:CD	2.18	0.49
7:H:82:TYR:HE1	7:H:182:LEU:CD1	2.25	0.49
19:P:153:LYS:CD	19:P:154:PRO:HD2	2.42	0.49
23:Z:39:ALA:O	23:Z:72:CYS:HA	2.13	0.49
36:j:50:TYR:CG	36:j:51:PRO:HA	2.47	0.49
9:J:40:LEU:C	9:J:40:LEU:HD13	2.38	0.49
21:Y:51:ARG:HB2	42:4:73:C:OP2	2.13	0.49
25:h:42:PRO:HA	25:h:45:ILE:HD11	1.94	0.49
25:h:98:ASP:O	25:h:102:ARG:HG2	2.12	0.49
34:U:85:TYR:CD2	34:U:133:PHE:HB2	2.47	0.49
6:D:257:PRO:HD2	6:D:258:GLN:CD	2.38	0.49
16:R:173:ARG:CZ	16:R:176:LYS:HD2	2.42	0.49
26:F:160:ASP:OD1	26:F:160:ASP:C	2.56	0.49

Continued on next page...

Continued from previous page...

Atom-1	Atom-2	Interatomic distance (Å)	Clash overlap (Å)
33:o:7:GLU:OE1	33:o:94:LEU:HD22	2.13	0.49
42:4:8:C:H42	43:1:363:C:H42	1.60	0.49
43:1:1078:C:H3'	43:1:1079:G:H5'	1.93	0.49
6:D:277:LEU:HD12	6:D:284:ILE:HG13	1.95	0.48
19:P:66:VAL:HG13	19:P:81:ARG:HG3	1.95	0.48
43:1:981:C:N4	43:1:982:C:H41	2.11	0.48
43:1:1588:G:H2'	43:1:1589:U:C6	2.48	0.48
10:O:181:LYS:HE3	10:O:181:LYS:CA	2.29	0.48
12:M:62:ILE:HG22	12:M:64:ILE:HG23	1.95	0.48
15:S:198:ASP:OD1	43:1:2585:U:N3	2.41	0.48
17:T:102:ARG:HD3	43:1:772:G:H4'	1.95	0.48
23:Z:77:HIS:ND1	49:Z:201:HOH:O	2.35	0.48
25:h:31:LEU:HD21	25:h:44:ARG:HH21	1.77	0.48
4:I:119:TRP:O	43:1:835:G:OP1	2.31	0.48
17:T:117:ARG:HD3	17:T:120:LYS:HZ1	1.76	0.48
26:F:155:ARG:NH1	49:F:302:HOH:O	2.41	0.48
39:A:242:ARG:CZ	39:A:246:SER:HB3	2.44	0.48
43:1:215:C:H2'	43:1:216:G:H8	1.78	0.48
3:C:276:ASP:O	3:C:280:LYS:HG3	2.13	0.48
4:I:35:ASP:O	4:I:36:LEU:HD13	2.13	0.48
12:M:11:ARG:NH1	12:M:58:THR:O	2.46	0.48
13:N:5:LYS:O	13:N:9:GLU:OE1	2.31	0.48
18:V:132:PRO:O	18:V:135:SER:OG	2.31	0.48
27:d:8:THR:HG22	27:d:67:ARG:NH1	2.27	0.48
42:4:116:C:HO2'	42:4:117:C:H6	1.61	0.48
43:1:164:G:O2'	43:1:165:G:H2'	2.14	0.48
6:D:213:TYR:HB2	41:3:32:A:C2	2.49	0.48
12:M:58:THR:CG2	12:M:59:ASP:N	2.76	0.48
25:h:6:ALA:HA	25:h:9:LEU:HB2	1.95	0.48
28:e:12:LYS:HG2	28:e:13:ILE:N	2.29	0.48
35:c:20:LEU:HD12	35:c:102:ALA:CB	2.44	0.48
43:1:982:C:O2'	43:1:983:G:O4'	2.31	0.48
1:B:158:ARG:HG2	1:B:181:GLN:HA	1.96	0.48
2:a:119:PRO:HG3	14:Q:92:VAL:HG21	1.94	0.48
3:C:39:GLN:OE1	3:C:103:ARG:HG2	2.13	0.48
7:H:1:MET:HB3	7:H:4:CYS:O	2.14	0.48
25:h:6:ALA:HB1	25:h:61:ILE:HD11	1.95	0.48
32:k:67:LYS:N	32:k:67:LYS:CD	2.76	0.48
35:c:40:ASP:HB3	35:c:42:LYS:HD3	1.96	0.48
4:I:84:SER:HA	4:I:141:ARG:HH12	1.76	0.48
16:R:162:ARG:HB3	16:R:163:ARG:HH21	1.78	0.48

Continued on next page...

Continued from previous page...

Atom-1	Atom-2	Interatomic distance (Å)	Clash overlap (Å)
21:Y:121:ARG:HG2	21:Y:125:ARG:NH2	2.29	0.48
24:b:22:LYS:HA	24:b:22:LYS:HD3	1.71	0.48
27:d:3:ILE:HG23	27:d:72:LEU:HB2	1.94	0.48
32:k:29:LYS:HG3	43:1:1413:C:N3	2.28	0.48
33:o:90:GLU:N	33:o:90:GLU:OE2	2.47	0.48
2:a:120:GLN:HA	2:a:141:VAL:CG2	2.43	0.48
6:D:59:ASP:HB2	6:D:80:SER:HB2	1.95	0.48
7:H:99:ALA:HB1	7:H:108:ILE:HD11	1.94	0.48
11:L:136:GLU:CD	11:L:136:GLU:N	2.72	0.48
15:S:56:ARG:HD2	17:T:148:ILE:CD1	2.43	0.48
17:T:81:ARG:HD3	49:T:223:HOH:O	2.13	0.48
28:e:129:ALA:HB2	43:1:1098:C:H5''	1.96	0.48
43:1:786:C:O2	43:1:786:C:H2'	2.14	0.48
6:D:143:GLU:HG2	6:D:148:HIS:HA	1.96	0.48
9:J:32:LYS:HG2	9:J:120:MET:SD	2.54	0.48
12:M:13:VAL:CG2	12:M:55:ALA:HB1	2.44	0.48
28:e:105:VAL:CG1	28:e:109:SER:HB2	2.43	0.48
29:g:73:PRO:O	43:1:1447:G:OP1	2.31	0.48
36:j:30:CYS:O	36:j:34:GLY:HA2	2.14	0.48
2:a:4:ARG:NH2	43:1:1113:U:OP2	2.45	0.48
14:Q:114:LYS:O	14:Q:115:ALA:HB3	2.13	0.48
30:f:45:VAL:O	30:f:48:ARG:HG3	2.14	0.48
3:C:231:SER:O	3:C:231:SER:OG	2.28	0.47
4:I:185:ARG:HG3	4:I:192:TYR:OH	2.14	0.47
6:D:190:GLY:O	6:D:196:PHE:HB2	2.14	0.47
7:H:35:ARG:NH2	49:H:201:HOH:O	2.47	0.47
12:M:71:GLU:HG2	12:M:72:GLN:N	2.28	0.47
20:X:102:PHE:O	20:X:104:THR:HG22	2.14	0.47
26:F:235:ILE:HG22	26:F:235:ILE:O	2.13	0.47
29:g:24:LYS:NZ	43:1:1332:A:OP1	2.46	0.47
6:D:220:GLU:OE1	6:D:220:GLU:C	2.57	0.47
25:h:88:LEU:HB3	25:h:92:MET:HG3	1.96	0.47
43:1:1598:G:O2'	43:1:1599:A:H5'	2.14	0.47
1:B:104:THR:HG22	43:1:2559:C:O2'	2.13	0.47
1:B:277:ASP:HB3	1:B:280:LYS:HE2	1.96	0.47
49:C:403:HOH:O	13:N:204:ARG:NH2	2.46	0.47
8:G:149:THR:HB	8:G:205:TYR:OH	2.14	0.47
12:M:53:ARG:O	15:S:189:ARG:NH2	2.47	0.47
16:R:47:SER:OG	16:R:49:ILE:HG12	2.13	0.47
22:W:3:THR:HG23	22:W:3:THR:O	2.14	0.47
26:F:41:LYS:O	26:F:45:VAL:HG23	2.13	0.47

Continued on next page...

Continued from previous page...

Atom-1	Atom-2	Interatomic distance (Å)	Clash overlap (Å)
27:d:89:GLU:HG2	27:d:90:ASN:HD22	1.79	0.47
30:f:36:ILE:HG23	30:f:41:GLU:HB2	1.96	0.47
43:1:2096:A:H2	43:1:2102:A:H62	1.61	0.47
6:D:221:ASP:OD2	6:D:224:THR:HB	2.14	0.47
32:k:36:VAL:HG21	32:k:57:ALA:HB2	1.96	0.47
32:k:65:LYS:HD2	32:k:65:LYS:C	2.40	0.47
35:c:107:ILE:O	35:c:108:LEU:HD13	2.14	0.47
43:1:593:G:OP2	49:1:2954:HOH:O	2.20	0.47
1:B:285:ILE:HG12	1:B:322:ILE:HG13	1.95	0.47
6:D:97:ALA:O	6:D:101:THR:HG22	2.15	0.47
23:Z:2:SER:N	35:c:67:SER:O	2.47	0.47
39:A:113:VAL:HG23	39:A:134:CYS:HB2	1.96	0.47
42:4:34:G:N3	42:4:34:G:C2'	2.77	0.47
3:C:270:GLU:H	3:C:270:GLU:CD	2.22	0.47
34:U:141:VAL:HG22	34:U:142:PHE:N	2.30	0.47
42:4:118:G:O2'	42:4:119:G:P	2.72	0.47
43:1:1699:A:H2'	43:1:1700:C:C6	2.50	0.47
6:D:140:ASP:OD1	6:D:140:ASP:N	2.33	0.47
6:D:269:PRO:HG2	6:D:271:ARG:HG2	1.96	0.47
9:J:167:PHE:N	9:J:167:PHE:CD1	2.81	0.47
13:N:121:VAL:O	13:N:122:ALA:HB2	2.13	0.47
17:T:116:ARG:HD3	43:1:804:G:H5'	1.97	0.47
30:f:74:MET:HE3	30:f:74:MET:HB3	1.77	0.47
30:f:93:ARG:NH1	49:f:201:HOH:O	2.46	0.47
41:3:75:G:C2'	41:3:76:U:OP2	2.63	0.47
43:1:1129:A:H2'	43:1:1130:G:C8	2.50	0.47
43:1:1982:C:O2'	43:1:1983:C:O5'	2.33	0.47
10:O:168:LYS:HD3	10:O:172:ASP:OD2	2.14	0.47
16:R:92:LYS:HE2	43:1:1326:A:O2'	2.15	0.47
27:d:3:ILE:HG23	27:d:3:ILE:O	2.14	0.47
29:g:72:ARG:NH1	43:1:1304:C:OP2	2.44	0.47
34:U:85:TYR:HE1	34:U:89:HIS:ND1	2.12	0.47
39:A:98:ILE:O	39:A:166:ILE:O	2.32	0.47
43:1:1344:G:H2'	43:1:1345:G:C8	2.49	0.47
15:S:35:GLN:HG2	15:S:93:HIS:NE2	2.30	0.47
19:P:26:LYS:NZ	49:P:302:HOH:O	2.44	0.47
4:I:187:ARG:NH2	4:I:189:GLU:OE2	2.45	0.47
6:D:22:ARG:HB3	6:D:28:THR:HG22	1.97	0.47
6:D:281:LYS:HE2	41:3:107:G:OP1	2.15	0.47
7:H:172:LEU:O	38:m:78:MET:HE3	2.15	0.47
12:M:73:LEU:CD1	12:M:77:ILE:HG13	2.44	0.47

Continued on next page...

Continued from previous page...

Atom-1	Atom-2	Interatomic distance (Å)	Clash overlap (Å)
21:Y:132:ARG:O	21:Y:132:ARG:HG2	2.14	0.47
23:Z:30:LEU:HD21	23:Z:40:ILE:HG13	1.97	0.47
27:d:22:LYS:O	27:d:26:ILE:HG12	2.15	0.47
32:k:38:LEU:N	32:k:38:LEU:HD23	2.30	0.47
32:k:42:THR:CG2	32:k:43:ALA:N	2.76	0.47
39:A:122:ASP:OD1	39:A:122:ASP:C	2.57	0.47
3:C:232:HIS:HA	3:C:233:PRO:HD3	1.78	0.46
9:J:37:LEU:O	9:J:41:THR:HG23	2.15	0.46
10:O:35:CYS:SG	10:O:101:VAL:HG13	2.55	0.46
20:X:89:ALA:HA	20:X:93:GLU:OE2	2.15	0.46
30:f:1:MET:HG2	30:f:5:LYS:NZ	2.29	0.46
35:c:104:LEU:O	35:c:106:SER:N	2.46	0.46
3:C:105:VAL:O	3:C:110:ARG:NH1	2.49	0.46
3:C:223:ARG:HG2	43:1:436:C:C2	2.51	0.46
6:D:269:PRO:CG	6:D:271:ARG:HG2	2.45	0.46
12:M:105:THR:O	12:M:109:MET:HG3	2.14	0.46
27:d:3:ILE:CG2	27:d:72:LEU:HB2	2.45	0.46
27:d:3:ILE:CG2	27:d:72:LEU:HD22	2.45	0.46
1:B:296:THR:HG22	1:B:297:GLU:N	2.26	0.46
26:F:226:TYR:O	26:F:229:GLU:HG2	2.15	0.46
32:k:69:GLU:OE2	32:k:71:GLN:NE2	2.48	0.46
35:c:40:ASP:HB3	35:c:42:LYS:HD2	1.97	0.46
35:c:72:ARG:CD	35:c:108:LEU:HB3	2.41	0.46
35:c:87:ARG:CG	35:c:87:ARG:NH1	2.78	0.46
37:l:47:SER:HB3	49:l:114:HOH:O	2.14	0.46
43:1:2291:C:H5'	43:1:2292:G:OP1	2.16	0.46
4:I:82:LYS:O	4:I:82:LYS:HG2	2.15	0.46
6:D:245:MET:HG3	6:D:246:TYR:N	2.30	0.46
8:G:104:LEU:C	8:G:104:LEU:HD13	2.40	0.46
32:k:8:GLU:H	32:k:8:GLU:CD	2.23	0.46
16:R:117:ARG:NE	43:1:1382:C:OP1	2.42	0.46
32:k:32:LEU:HA	32:k:35:LYS:HZ3	1.81	0.46
43:1:2111:G:N3	43:1:2111:G:H2'	2.29	0.46
2:a:88:ASP:OD1	2:a:89:GLY:N	2.49	0.46
6:D:270:VAL:C	6:D:273:ALA:H	2.24	0.46
7:H:4:CYS:HB3	7:H:56:TRP:CE3	2.51	0.46
7:H:100:THR:OG1	7:H:111:ARG:NH2	2.49	0.46
17:T:2:THR:HA	43:1:2048:G:C6	2.51	0.46
20:X:130:GLN:O	20:X:133:ASP:OD1	2.34	0.46
30:f:54:HIS:CD2	30:f:56:LYS:HB3	2.50	0.46
30:f:54:HIS:CD2	30:f:57:SER:H	2.30	0.46

Continued on next page...

Continued from previous page...

Atom-1	Atom-2	Interatomic distance (Å)	Clash overlap (Å)
34:U:85:TYR:O	34:U:88:THR:HG22	2.16	0.46
43:1:435:C:OP2	43:1:435:C:H4'	2.15	0.46
43:1:2562:C:C5	43:1:2563:C:C5	3.03	0.46
9:J:37:LEU:HD21	9:J:125:MET:HE3	1.98	0.46
16:R:173:ARG:NH1	16:R:176:LYS:HD2	2.31	0.46
20:X:66:ILE:HG22	20:X:71:ASN:HD22	1.81	0.46
33:o:27:LYS:HB2	33:o:27:LYS:HE3	1.74	0.46
33:o:88:ARG:HD3	33:o:88:ARG:N	2.31	0.46
34:U:127:LYS:HG3	34:U:144:VAL:HG11	1.97	0.46
39:A:5:ILE:HD12	39:A:208:ASP:O	2.15	0.46
6:D:108:ARG:CZ	6:D:259:ALA:HB2	2.46	0.46
6:D:241:ARG:HB3	6:D:241:ARG:NH1	2.30	0.46
14:Q:23:ASN:CB	14:Q:26:ILE:HD12	2.38	0.46
18:V:115:LYS:O	18:V:115:LYS:HG2	2.16	0.46
26:F:126:ASP:OD1	26:F:221:GLY:HA2	2.16	0.46
26:F:205:ALA:HB2	26:F:234:MET:HE3	1.97	0.46
35:c:16:LEU:HD13	35:c:16:LEU:O	2.15	0.46
1:B:374:ARG:NH2	1:B:375:GLN:OE1	2.49	0.46
11:L:160:LYS:HE3	11:L:161:PRO:HD2	1.98	0.46
20:X:90:SER:O	20:X:93:GLU:HG2	2.16	0.46
25:h:44:ARG:NH2	25:h:47:ARG:HG2	2.31	0.46
30:f:115:ASN:OD1	30:f:118:ALA:HB2	2.15	0.46
34:U:85:TYR:CE1	34:U:89:HIS:ND1	2.83	0.46
37:l:19:MET:HE3	37:l:19:MET:HA	1.97	0.46
42:4:115:C:O2'	42:4:118:G:O6	2.27	0.46
43:1:1307:C:HO2'	43:1:1308:C:P	2.38	0.46
7:H:30:LYS:HB2	7:H:80:VAL:O	2.16	0.46
9:J:35:LYS:HB3	9:J:120:MET:CE	2.46	0.46
15:S:120:TYR:OH	15:S:122:GLU:OE2	2.24	0.46
26:F:29:GLU:OE1	26:F:29:GLU:CA	2.64	0.46
34:U:85:TYR:CD2	34:U:133:PHE:HD1	2.33	0.46
43:1:3:C:O2'	43:1:4:G:OP2	2.26	0.46
4:I:61:SER:HA	4:I:126:VAL:HG12	1.98	0.45
15:S:36:LYS:CD	15:S:94:ILE:HG23	2.46	0.45
17:T:83:ARG:HE	17:T:83:ARG:HB3	1.46	0.45
22:W:22:MET:O	22:W:29:LEU:HD12	2.16	0.45
27:d:98:LYS:HE3	43:1:2681:A:OP1	2.16	0.45
34:U:64:ARG:HB3	34:U:64:ARG:CZ	2.45	0.45
43:1:1981:G:H2'	43:1:1982:C:O4'	2.15	0.45
4:I:85:PHE:HA	4:I:139:ARG:O	2.16	0.45
4:I:174:THR:HG22	4:I:196:ASN:OD1	2.16	0.45

Continued on next page...

Continued from previous page...

Atom-1	Atom-2	Interatomic distance (Å)	Clash overlap (Å)
9:J:35:LYS:HB3	9:J:120:MET:HE1	1.97	0.45
10:O:158:LEU:HD23	10:O:158:LEU:HA	1.75	0.45
13:N:76:VAL:HG13	49:1:4859:HOH:O	2.17	0.45
16:R:82:ARG:HB3	16:R:82:ARG:CZ	2.45	0.45
23:Z:33:ASN:OD1	23:Z:35:ARG:N	2.45	0.45
39:A:5:ILE:CG2	39:A:6:ARG:N	2.79	0.45
43:1:2626:G:O2'	43:1:2682:G:N2	2.49	0.45
15:S:36:LYS:HG3	15:S:36:LYS:O	2.16	0.45
16:R:104:ARG:HD3	16:R:108:ARG:NH2	2.32	0.45
18:V:16:ARG:O	18:V:17:ILE:HD13	2.16	0.45
18:V:125:LYS:HE3	18:V:125:LYS:HB3	1.80	0.45
23:Z:117:ARG:HH22	23:Z:123:ARG:HH12	1.63	0.45
25:h:43:GLU:CD	25:h:43:GLU:H	2.24	0.45
28:e:92:MET:HE2	28:e:92:MET:N	2.31	0.45
34:U:67:VAL:C	34:U:111:SER:HB3	2.42	0.45
34:U:93:ASN:ND2	34:U:93:ASN:C	2.73	0.45
43:1:1906:C:O2'	43:1:1907:U:C6	2.68	0.45
1:B:250:ALA:HB3	43:1:2301:U:O2	2.17	0.45
6:D:126:TYR:N	6:D:127:PRO:HD3	2.32	0.45
6:D:270:VAL:CA	6:D:273:ALA:HB3	2.47	0.45
6:D:272:GLN:HG3	41:3:59:C:C4'	2.46	0.45
7:H:1:MET:CE	7:H:3:LEU:HB3	2.45	0.45
9:J:108:GLU:OE1	9:J:110:ILE:N	2.49	0.45
9:J:166:GLU:C	9:J:167:PHE:HD1	2.24	0.45
12:M:12:LEU:HD12	12:M:25:ALA:O	2.17	0.45
23:Z:9:GLY:HA3	23:Z:84:ARG:NH2	2.32	0.45
23:Z:94:SER:O	23:Z:98:VAL:HG13	2.17	0.45
32:k:19:GLY:HA3	32:k:40:LEU:HD11	1.98	0.45
39:A:2:GLY:N	49:A:404:HOH:O	2.48	0.45
43:1:353:U:OP2	49:1:2958:HOH:O	2.21	0.45
3:C:264:ILE:HD13	14:Q:123:ASP:CG	2.41	0.45
6:D:141:GLU:OE1	6:D:141:GLU:CA	2.65	0.45
8:G:207:LYS:HB3	8:G:207:LYS:HE3	1.73	0.45
15:S:167:LYS:HA	15:S:170:MET:HE2	1.99	0.45
25:h:42:PRO:HA	25:h:45:ILE:CD1	2.47	0.45
32:k:11:MET:SD	32:k:11:MET:N	2.86	0.45
35:c:88:GLN:OE1	35:c:88:GLN:N	2.49	0.45
43:1:1599:A:C2'	43:1:1600:A:OP2	2.65	0.45
9:J:21:ILE:HD11	9:J:123:TYR:CD2	2.52	0.45
23:Z:65:ARG:HG2	23:Z:66:VAL:N	2.32	0.45
25:h:122:VAL:O	25:h:123:LYS:HB2	2.17	0.45

Continued on next page...

Continued from previous page...

Atom-1	Atom-2	Interatomic distance (Å)	Clash overlap (Å)
27:d:64:ARG:NH1	43:1:2474:G:OP2	2.50	0.45
29:g:78:LEU:CD1	29:g:83:LEU:HB2	2.46	0.45
35:c:108:LEU:N	35:c:108:LEU:HD22	2.32	0.45
1:B:302:ASP:N	1:B:302:ASP:OD1	2.48	0.45
8:G:50:ARG:HH11	8:G:50:ARG:CB	2.29	0.45
10:O:130:ARG:NH1	43:1:1013:C:H2'	2.31	0.45
26:F:55:GLU:OE1	26:F:55:GLU:HA	2.17	0.45
42:4:16:G:O2'	42:4:17:A:P	2.75	0.45
43:1:2118:A:H2'	43:1:2119:A:C8	2.52	0.45
43:1:2261:C:H2'	43:1:2262:G:O4'	2.16	0.45
4:I:154:ARG:NH1	43:1:2259:A:OP1	2.50	0.45
5:p:60:CYS:O	5:p:61:SER:HB2	2.16	0.45
9:J:35:LYS:NZ	9:J:39:GLN:HB2	2.32	0.45
9:J:65:ILE:HD11	43:1:2103:C:C4'	2.47	0.45
21:Y:59:THR:CG2	21:Y:103:ASN:HB2	2.46	0.45
7:H:137:LYS:HG3	7:H:138:ASP:H	1.81	0.45
8:G:94:ILE:HG23	8:G:106:GLU:HG2	1.99	0.45
14:Q:129:LYS:HD3	14:Q:133:ASP:O	2.17	0.45
18:V:77:LYS:HE2	18:V:77:LYS:HB2	1.73	0.45
21:Y:39:ARG:HD3	21:Y:45:LYS:HA	1.99	0.45
43:1:1293:C:HO2'	43:1:1294:C:P	2.39	0.45
43:1:1514:C:H2'	43:1:1515:G:O4'	2.17	0.45
43:1:2008:C:C4'	43:1:2008:C:OP2	2.65	0.45
43:1:2099:G:N3	43:1:2099:G:H2'	2.31	0.45
1:B:125:ALA:O	1:B:127:LYS:HE3	2.17	0.45
8:G:162:ARG:HA	8:G:162:ARG:HD3	1.82	0.45
13:N:121:VAL:CG1	13:N:131:GLU:HG3	2.46	0.45
18:V:130:ARG:O	18:V:130:ARG:HG3	2.16	0.45
26:F:182:GLU:OE2	26:F:187:GLY:HA3	2.17	0.45
43:1:1983:C:H2'	43:1:1984:G:C4'	2.47	0.45
1:B:47:LEU:HD22	1:B:163:THR:HG21	2.00	0.44
3:C:17:GLU:O	3:C:18:LEU:HD23	2.17	0.44
3:C:128:GLU:HG2	3:C:134:ILE:HD11	2.00	0.44
9:J:51:ARG:O	9:J:61:ARG:HG3	2.17	0.44
22:W:48:ARG:HB3	22:W:48:ARG:HH11	1.81	0.44
23:Z:135:ALA:HB3	29:g:74:TYR:CE2	2.52	0.44
28:e:95:LYS:HD2	28:e:95:LYS:HA	1.69	0.44
33:o:19:THR:HG23	33:o:21:HIS:CE1	2.52	0.44
43:1:131:G:O2'	43:1:132:C:H6	1.99	0.44
43:1:867:A:N3	43:1:867:A:H2'	2.30	0.44
43:1:1804:C:H2'	43:1:1805:C:O4'	2.17	0.44

Continued on next page...

Continued from previous page...

Atom-1	Atom-2	Interatomic distance (Å)	Clash overlap (Å)
43:1:2609:C:H42	43:1:2685:C:N4	2.15	0.44
4:I:201:SER:O	4:I:202:ARG:NH1	2.50	0.44
9:J:106:ILE:HD13	9:J:112:LEU:CD2	2.40	0.44
43:1:919:C:H3'	43:1:920:G:H5'	1.98	0.44
43:1:1130:G:H2'	43:1:1131:C:O4'	2.17	0.44
43:1:2303:U:H2'	43:1:2304:U:C6	2.52	0.44
5:p:26:LEU:CD1	39:A:180:LEU:HD22	2.46	0.44
17:T:119:ALA:O	17:T:123:GLY:N	2.49	0.44
18:V:63:LEU:HD22	18:V:78:VAL:HG12	1.97	0.44
32:k:64:CYS:C	32:k:67:LYS:HG2	2.42	0.44
1:B:104:THR:HG23	43:1:2560:C:H4'	1.99	0.44
1:B:251:CYS:HA	49:1:2901:HOH:O	2.18	0.44
2:a:76:ASP:HB3	2:a:116:GLY:HA3	1.99	0.44
12:M:75:LYS:HB3	12:M:75:LYS:HE3	1.80	0.44
13:N:76:VAL:HG12	13:N:77:HIS:ND1	2.32	0.44
19:P:10:ASN:HD21	19:P:152:PRO:HD2	1.82	0.44
19:P:14:GLY:HA3	19:P:101:ALA:HB2	1.98	0.44
21:Y:120:LYS:HB3	21:Y:120:LYS:HE3	1.74	0.44
43:1:2169:A:H2'	43:1:2170:A:C8	2.52	0.44
43:1:2496:C:HO2'	43:1:2497:C:P	2.40	0.44
4:I:87:LEU:HD11	4:I:136:LEU:HD23	2.00	0.44
5:p:51:ALA:HB3	5:p:54:ILE:HD12	1.99	0.44
11:L:189:ILE:HG22	11:L:193:LYS:HE3	1.99	0.44
13:N:124:ASP:OD1	13:N:124:ASP:C	2.60	0.44
35:c:16:LEU:CD1	35:c:20:LEU:HD23	2.46	0.44
43:1:1906:C:O2'	43:1:1907:U:P	2.75	0.44
43:1:1980:G:H2'	43:1:1981:G:O4'	2.18	0.44
43:1:2319:G:H4'	43:1:2320:C:OP2	2.18	0.44
11:L:118:LYS:HE3	11:L:118:LYS:HB3	1.73	0.44
11:L:135:GLU:OE1	31:i:15:VAL:CG1	2.66	0.44
16:R:154:LYS:NZ	16:R:155:LYS:HE3	2.32	0.44
39:A:66:MET:HE2	39:A:66:MET:HB2	1.81	0.44
1:B:55:HIS:O	1:B:56:VAL:HG13	2.17	0.44
1:B:90:ILE:HD13	1:B:104:THR:HB	1.99	0.44
7:H:3:LEU:HD12	7:H:3:LEU:HA	1.83	0.44
9:J:44:GLU:OE2	41:3:39:C:O2'	2.36	0.44
13:N:189:ARG:NH1	49:N:303:HOH:O	2.39	0.44
15:S:119:MET:HE2	15:S:121:ARG:HH11	1.83	0.44
16:R:130:ASN:CG	16:R:130:ASN:O	2.61	0.44
24:b:18:ARG:HG2	43:1:685:C:OP1	2.17	0.44
26:F:106:ILE:O	26:F:107:ASN:HB2	2.18	0.44

Continued on next page...

Continued from previous page...

Atom-1	Atom-2	Interatomic distance (Å)	Clash overlap (Å)
1:B:55:HIS:HB2	1:B:357:SER:HB3	2.00	0.44
2:a:98:GLU:OE1	2:a:98:GLU:CA	2.63	0.44
4:I:202:ARG:HB2	4:I:202:ARG:CZ	2.47	0.44
8:G:163:THR:HG23	49:1:4722:HOH:O	2.18	0.44
18:V:89:VAL:HA	18:V:99:TYR:HB3	2.00	0.44
18:V:108:ILE:CG1	18:V:109:ASN:N	2.80	0.44
21:Y:81:GLU:O	21:Y:81:GLU:HG2	2.18	0.44
25:h:40:PRO:HB2	25:h:45:ILE:HG21	2.00	0.44
26:F:20:SER:HB3	26:F:23:GLU:CD	2.43	0.44
35:c:48:MET:HE3	35:c:48:MET:HB3	1.83	0.44
43:1:457:A:HO2'	43:1:470:C:HO2'	1.66	0.44
43:1:1858:A:OP2	49:1:2959:HOH:O	2.21	0.44
1:B:374:ARG:HD3	1:B:380:LYS:O	2.18	0.44
4:I:169:ARG:NH1	4:I:169:ARG:CG	2.79	0.44
39:A:7:VAL:CG1	43:1:1669:A:H5''	2.48	0.44
42:4:16:G:O2'	42:4:17:A:C8	2.71	0.44
43:1:867:A:N6	49:1:3188:HOH:O	2.50	0.44
43:1:1861:G:O2'	43:1:1863:G:OP2	2.24	0.44
6:D:293:LYS:HA	6:D:293:LYS:HD3	1.68	0.43
11:L:79:PRO:HB3	11:L:170:HIS:HB3	2.00	0.43
11:L:87:VAL:HB	43:1:73:G:H5'	2.00	0.43
43:1:2105:U:H2'	43:1:2106:C:C6	2.53	0.43
43:1:2419:G:OP2	49:1:2957:HOH:O	2.21	0.43
43:1:2496:C:O2'	43:1:2497:C:O5'	2.35	0.43
43:1:2626:G:O2'	43:1:2627:C:P	2.76	0.43
7:H:91:ALA:HB1	38:m:78:MET:CE	2.48	0.43
9:J:49:LYS:HD2	9:J:64:LYS:HD2	2.00	0.43
10:O:155:LYS:HB3	10:O:155:LYS:HE3	1.66	0.43
10:O:166:GLN:HA	10:O:169:ILE:HD12	2.00	0.43
11:L:73:LYS:HB2	11:L:73:LYS:HE3	1.64	0.43
20:X:40:LYS:NZ	42:4:116:C:N4	2.66	0.43
21:Y:43:LYS:HB2	21:Y:43:LYS:HE2	1.73	0.43
34:U:97:HIS:C	34:U:97:HIS:ND1	2.75	0.43
34:U:148:ASP:CG	34:U:149:LYS:H	2.25	0.43
3:C:96:THR:HG22	3:C:97:VAL:N	2.33	0.43
4:I:42:LYS:HE2	4:I:42:LYS:HB2	1.79	0.43
4:I:195:ASN:HD21	43:1:722:G:C4'	2.31	0.43
6:D:58:LYS:C	6:D:93:THR:HG21	2.43	0.43
6:D:241:ARG:HB3	6:D:241:ARG:CZ	2.49	0.43
7:H:142:LEU:HD12	7:H:150:VAL:HG23	1.99	0.43
8:G:56:THR:O	8:G:59:GLN:HG2	2.17	0.43

Continued on next page...

Continued from previous page...

Atom-1	Atom-2	Interatomic distance (Å)	Clash overlap (Å)
16:R:163:ARG:HE	16:R:163:ARG:N	2.17	0.43
30:f:101:VAL:HB	30:f:104:ARG:HB2	2.00	0.43
43:1:2010:C:O2'	43:1:2011:G:H5''	2.19	0.43
43:1:2638:U:H2'	43:1:2639:G:O4'	2.18	0.43
4:I:52:LEU:HD23	4:I:136:LEU:HD13	2.01	0.43
15:S:122:GLU:HG3	15:S:165:ARG:HG2	2.00	0.43
20:X:103:GLU:OE2	20:X:103:GLU:HA	2.17	0.43
31:i:16:ARG:HG3	31:i:17:ILE:H	1.83	0.43
42:4:16:G:H1'	43:1:355:A:N6	2.33	0.43
43:1:459:A:H4'	43:1:460:C:OP1	2.18	0.43
43:1:1893:C:H2'	43:1:1894:U:C6	2.54	0.43
1:B:332:LYS:O	1:B:333:ARG:HB2	2.19	0.43
3:C:104:LYS:HA	43:1:427:C:C5	2.50	0.43
6:D:156:ILE:CG2	6:D:159:ALA:HB3	2.48	0.43
16:R:105:LEU:HD23	16:R:138:LEU:HD23	2.01	0.43
20:X:128:ASP:OD1	20:X:128:ASP:N	2.48	0.43
43:1:804:G:H2'	43:1:805:C:C6	2.52	0.43
43:1:1892:C:H2'	43:1:1893:C:C6	2.53	0.43
8:G:144:VAL:HG11	8:G:177:THR:HG23	2.00	0.43
10:O:167:ASP:O	10:O:171:ILE:HG12	2.19	0.43
13:N:148:ILE:O	13:N:148:ILE:HG13	2.19	0.43
18:V:57:SER:O	18:V:60:ASP:OD1	2.37	0.43
30:f:84:PRO:HG3	43:1:374:C:H5	1.83	0.43
43:1:706:C:O2	43:1:2059:A:H2'	2.18	0.43
43:1:875:C:H2'	43:1:876:C:O4'	2.18	0.43
23:Z:117:ARG:CB	23:Z:117:ARG:HH11	2.30	0.43
28:e:12:LYS:HG2	28:e:13:ILE:H	1.83	0.43
32:k:77:GLU:N	32:k:77:GLU:OE1	2.52	0.43
35:c:32:ASP:O	35:c:36:ARG:HG3	2.18	0.43
1:B:66:ASN:O	1:B:70:ARG:NE	2.52	0.43
6:D:119:GLU:OE2	6:D:119:GLU:CA	2.66	0.43
6:D:283:ARG:H	6:D:283:ARG:HG3	1.67	0.43
7:H:118:LYS:HE3	7:H:120:ARG:NH1	2.33	0.43
7:H:124:CYS:HB3	7:H:128:VAL:HB	2.01	0.43
10:O:111:ARG:HA	10:O:111:ARG:HD3	1.83	0.43
13:N:96:ARG:NH1	13:N:104:GLN:OE1	2.52	0.43
23:Z:101:VAL:HG13	23:Z:102:THR:N	2.34	0.43
34:U:133:PHE:O	34:U:136:GLN:HB2	2.19	0.43
43:1:1312:C:H2'	43:1:1313:C:C6	2.53	0.43
43:1:2380:C:H2'	43:1:2381:G:C8	2.54	0.43
3:C:139:SER:O	3:C:140:ILE:HD13	2.19	0.43

Continued on next page...

Continued from previous page...

Atom-1	Atom-2	Interatomic distance (Å)	Clash overlap (Å)
4:I:39:ARG:HD3	43:1:722:G:OP1	2.18	0.43
6:D:103:LEU:HD12	6:D:177:ALA:HB2	2.01	0.43
9:J:90:GLU:OE1	9:J:172:THR:HG23	2.19	0.43
16:R:141:HIS:CD2	16:R:145:MET:HE3	2.54	0.43
18:V:71:LYS:HD2	18:V:71:LYS:HA	1.76	0.43
19:P:93:ILE:HG22	19:P:148:LEU:HD12	2.01	0.43
20:X:91:LYS:N	20:X:92:PRO:HD2	2.33	0.43
38:m:119:ARG:HD2	38:m:120:LYS:O	2.19	0.43
42:4:16:G:HO2'	42:4:17:A:P	2.41	0.43
43:1:1587:G:H2'	43:1:1588:G:N9	2.33	0.43
6:D:71:LYS:HD3	41:3:113:G:O2'	2.18	0.43
9:J:90:GLU:CD	9:J:172:THR:HG23	2.43	0.43
12:M:13:VAL:HG21	12:M:55:ALA:HB1	2.01	0.43
25:h:78:LYS:HA	25:h:78:LYS:HD2	1.77	0.43
34:U:134:LEU:O	34:U:137:ASP:O	2.37	0.43
43:1:223:A:H2'	43:1:224:G:O4'	2.19	0.43
7:H:19:ILE:CD1	7:H:24:VAL:HG13	2.49	0.42
7:H:89:ARG:HD2	7:H:89:ARG:HA	1.73	0.42
10:O:55:MET:HE1	10:O:142:ILE:HB	2.01	0.42
16:R:15:LEU:C	16:R:16:LYS:HE2	2.43	0.42
18:V:87:ARG:HD3	18:V:101:GLN:O	2.19	0.42
19:P:9:ASP:C	19:P:11:LEU:HD23	2.43	0.42
27:d:5:TYR:CE1	27:d:98:LYS:HG3	2.54	0.42
35:c:45:LEU:HD11	35:c:72:ARG:HG3	2.00	0.42
43:1:1096:C:H2'	43:1:1097:C:C6	2.54	0.42
6:D:59:ASP:CA	6:D:93:THR:HG22	2.48	0.42
6:D:241:ARG:HH12	6:D:244:ALA:CB	2.31	0.42
9:J:116:TYR:OH	9:J:118:PRO:HA	2.19	0.42
17:T:81:ARG:NH1	43:1:2150:G:OP2	2.44	0.42
42:4:118:G:H1'	42:4:119:G:O4'	2.19	0.42
43:1:2535:U:H4'	43:1:2536:A:OP1	2.17	0.42
3:C:156:LEU:HD23	3:C:156:LEU:HA	1.78	0.42
15:S:128:SER:O	15:S:132:MET:HG2	2.19	0.42
16:R:156:LYS:O	16:R:160:GLU:HB2	2.19	0.42
25:h:45:ILE:HD11	49:4:383:HOH:O	2.18	0.42
26:F:102:ARG:HD2	43:1:810:G:H5''	2.01	0.42
26:F:107:ASN:HD22	26:F:204:SER:HA	1.82	0.42
32:k:37:LYS:C	32:k:38:LEU:HD23	2.44	0.42
1:B:57:MET:CE	22:W:1:MET:HE2	2.49	0.42
3:C:134:ILE:C	3:C:134:ILE:CD1	2.92	0.42
6:D:185:MET:HE2	6:D:196:PHE:CZ	2.55	0.42

Continued on next page...

Continued from previous page...

Atom-1	Atom-2	Interatomic distance (Å)	Clash overlap (Å)
9:J:21:ILE:HD13	9:J:33:ALA:CB	2.45	0.42
11:L:81:GLN:HG3	11:L:172:GLY:O	2.19	0.42
11:L:110:GLN:OE1	11:L:110:GLN:HA	2.19	0.42
17:T:56:TYR:CZ	17:T:78:LYS:HG3	2.54	0.42
43:1:1376:C:H2'	43:1:1377:G:O4'	2.19	0.42
43:1:1471:G:H2'	43:1:1471:G:N3	2.34	0.42
5:p:83:ILE:HD12	39:A:111:THR:HG23	1.99	0.42
6:D:3:TRP:N	6:D:3:TRP:CE3	2.87	0.42
6:D:156:ILE:HG22	6:D:159:ALA:HB3	2.01	0.42
6:D:270:VAL:O	6:D:270:VAL:HG22	2.19	0.42
7:H:183:GLN:HG3	7:H:183:GLN:O	2.19	0.42
9:J:61:ARG:HG2	9:J:62:GLY:N	2.34	0.42
14:Q:62:LEU:HD12	14:Q:62:LEU:HA	1.86	0.42
19:P:152:PRO:O	19:P:153:LYS:HB2	2.18	0.42
23:Z:18:ARG:HB2	43:1:1300:G:O6	2.20	0.42
33:o:19:THR:HG23	33:o:21:HIS:HE1	1.85	0.42
35:c:48:MET:HE1	35:c:57:LYS:CG	2.29	0.42
43:1:2263:C:O2	43:1:2263:C:H2'	2.18	0.42
4:I:175:GLU:OE1	4:I:175:GLU:N	2.50	0.42
8:G:29:THR:N	8:G:30:PRO:HD2	2.35	0.42
8:G:64:ILE:CG2	8:G:65:SER:N	2.83	0.42
29:g:93:ASN:HB3	29:g:97:GLN:OE1	2.20	0.42
43:1:1422:U:H2'	43:1:1423:C:C6	2.54	0.42
1:B:95:THR:OG1	1:B:98:GLY:O	2.32	0.42
1:B:186:ALA:HB3	1:B:190:GLU:CD	2.45	0.42
3:C:35:PHE:O	3:C:39:GLN:HG2	2.20	0.42
3:C:298:PHE:HE2	26:F:145:LYS:HE3	1.84	0.42
11:L:161:PRO:O	11:L:165:GLN:HG2	2.19	0.42
17:T:17:ARG:NH1	17:T:47:ALA:HB2	2.35	0.42
27:d:3:ILE:HG21	27:d:72:LEU:HD22	2.02	0.42
43:1:1887:A:N3	43:1:1887:A:H2'	2.34	0.42
1:B:245:GLY:HA3	43:1:1519:G:H5''	2.01	0.42
2:a:135:GLU:OE2	11:L:200:LEU:HB3	2.20	0.42
10:O:79:ARG:HD3	10:O:79:ARG:HA	1.85	0.42
16:R:154:LYS:HB3	16:R:154:LYS:HE3	1.64	0.42
16:R:154:LYS:HD2	16:R:154:LYS:O	2.20	0.42
23:Z:118:ARG:HD3	23:Z:124:ASP:OD2	2.19	0.42
25:h:7:LYS:CE	42:4:66:G:OP1	2.68	0.42
34:U:92:ILE:HG13	34:U:99:VAL:HG22	2.02	0.42
34:U:151:THR:OG1	34:U:152:TYR:N	2.52	0.42
39:A:126:LEU:O	43:1:1664:G:OP2	2.37	0.42

Continued on next page...

Continued from previous page...

Atom-1	Atom-2	Interatomic distance (Å)	Clash overlap (Å)
43:1:1579:G:N2	43:1:1585:C:C2	2.88	0.42
15:S:159:ALA:HB3	15:S:162:ASP:OD1	2.20	0.42
17:T:51:GLY:HA3	17:T:92:ARG:HG2	2.02	0.42
32:k:58:LYS:O	32:k:62:LYS:HG3	2.20	0.42
36:j:5:ALA:HA	43:1:603:C:OP2	2.20	0.42
2:a:34:LYS:HE2	2:a:34:LYS:HB2	1.80	0.42
4:I:45:ASP:O	4:I:46:PHE:HB2	2.19	0.42
7:H:161:LEU:HD23	7:H:161:LEU:HA	1.83	0.42
11:L:135:GLU:OE1	31:i:15:VAL:HG13	2.20	0.42
16:R:23:ARG:HD3	16:R:23:ARG:HA	1.84	0.42
17:T:116:ARG:O	17:T:120:LYS:NZ	2.48	0.42
30:f:4:ILE:O	30:f:4:ILE:HG13	2.19	0.42
35:c:52:CYS:SG	35:c:53:PRO:HD2	2.60	0.42
43:1:1419:G:H2'	43:1:1420:C:C6	2.55	0.42
43:1:2614:G:O2'	43:1:2615:G:H2'	2.20	0.42
1:B:364:HIS:NE2	43:1:2501:C:OP1	2.53	0.41
5:p:17:ARG:O	43:1:1618:A:N1	2.53	0.41
8:G:220:ASP:CB	8:G:221:GLU:OE1	2.68	0.41
10:O:177:GLU:HG3	10:O:178:ALA:N	2.35	0.41
17:T:56:TYR:OH	17:T:78:LYS:HG3	2.20	0.41
19:P:44:PHE:CE1	19:P:94:LEU:HD23	2.55	0.41
29:g:65:ARG:CD	43:1:1309:G:H5'	2.50	0.41
31:i:8:LEU:HD23	31:i:8:LEU:HA	1.73	0.41
39:A:9:ARG:NH1	49:A:401:HOH:O	2.30	0.41
43:1:1809:G:N3	49:1:2921:HOH:O	2.37	0.41
2:a:4:ARG:HG3	49:1:3981:HOH:O	2.19	0.41
3:C:307:LEU:HD13	3:C:307:LEU:HA	1.92	0.41
5:p:6:LYS:NZ	5:p:6:LYS:CB	2.78	0.41
7:H:26:VAL:HG12	7:H:80:VAL:HG21	2.01	0.41
8:G:64:ILE:HD13	8:G:64:ILE:HA	1.78	0.41
8:G:187:GLU:CD	8:G:187:GLU:H	2.28	0.41
15:S:119:MET:HE2	15:S:121:ARG:NH1	2.35	0.41
20:X:87:ARG:HB2	49:X:202:HOH:O	2.19	0.41
43:1:1377:G:O2'	43:1:1378:G:H5'	2.20	0.41
1:B:85:ILE:O	1:B:161:ALA:HA	2.20	0.41
4:I:162:ARG:HE	4:I:162:ARG:HB3	1.77	0.41
4:I:185:ARG:HE	4:I:185:ARG:HB3	1.63	0.41
9:J:23:ILE:HD12	9:J:23:ILE:C	2.44	0.41
13:N:9:GLU:OE1	13:N:9:GLU:N	2.53	0.41
14:Q:16:ARG:NH2	14:Q:20:LYS:HD2	2.34	0.41
26:F:30:LYS:HB3	26:F:30:LYS:HE3	1.63	0.41

Continued on next page...

Continued from previous page...

Atom-1	Atom-2	Interatomic distance (Å)	Clash overlap (Å)
42:4:116:C:H2'	42:4:117:C:C6	2.55	0.41
43:1:161:C:H2'	43:1:163:A:H2	1.86	0.41
43:1:1693:A:H2'	43:1:1694:C:O4'	2.20	0.41
4:I:195:ASN:HD21	43:1:722:G:H4'	1.85	0.41
6:D:253:ILE:O	6:D:257:PRO:HB3	2.20	0.41
6:D:283:ARG:HG3	6:D:283:ARG:HH11	1.84	0.41
7:H:111:ARG:O	7:H:112:ASN:HB3	2.20	0.41
17:T:20:ARG:C	17:T:21:ARG:HG2	2.45	0.41
32:k:58:LYS:HE2	32:k:58:LYS:N	2.33	0.41
35:c:16:LEU:O	35:c:20:LEU:HD23	2.20	0.41
41:3:36:G:O2'	41:3:43:A:N1	2.49	0.41
43:1:1587:G:H2'	43:1:1588:G:C8	2.55	0.41
1:B:265:ALA:C	1:B:266:ARG:HG2	2.46	0.41
4:I:76:ILE:HG23	4:I:85:PHE:CZ	2.55	0.41
5:p:25:GLN:HA	5:p:25:GLN:OE1	2.19	0.41
5:p:28:LYS:HE3	5:p:28:LYS:HB3	1.90	0.41
6:D:275:LEU:H	6:D:275:LEU:CD2	2.33	0.41
6:D:288:LYS:HA	6:D:288:LYS:HD3	1.85	0.41
7:H:102:VAL:O	7:H:103:ASP:HB2	2.20	0.41
8:G:47:LEU:HD23	8:G:47:LEU:HA	1.92	0.41
23:Z:103:LYS:O	23:Z:107:ILE:HG13	2.21	0.41
39:A:7:VAL:HG11	43:1:1669:A:H5''	2.02	0.41
6:D:59:ASP:HA	6:D:93:THR:CG2	2.49	0.41
6:D:248:LYS:HE3	6:D:248:LYS:HB3	1.81	0.41
9:J:28:ASP:HB3	9:J:32:LYS:CE	2.47	0.41
9:J:108:GLU:OE1	9:J:110:ILE:HB	2.20	0.41
11:L:219:ARG:O	11:L:219:ARG:HG2	2.19	0.41
16:R:38:ARG:HH12	43:1:1273:G:H3'	1.84	0.41
17:T:118:LEU:O	17:T:122:THR:HG22	2.20	0.41
19:P:153:LYS:CG	19:P:154:PRO:HD2	2.50	0.41
25:h:14:GLN:OE1	25:h:14:GLN:HA	2.20	0.41
28:e:126:ASN:OD1	28:e:126:ASN:N	2.53	0.41
34:U:69:CYS:HA	34:U:154:LEU:CD1	2.50	0.41
4:I:30:LYS:HE2	4:I:66:GLU:HB3	2.03	0.41
6:D:135:GLU:C	6:D:135:GLU:OE1	2.64	0.41
9:J:166:GLU:HB3	9:J:167:PHE:CD1	2.56	0.41
12:M:72:GLN:C	12:M:72:GLN:OE1	2.63	0.41
16:R:81:ARG:O	16:R:81:ARG:CG	2.68	0.41
22:W:54:LEU:CD1	22:W:63:GLU:HG2	2.50	0.41
24:b:33:LYS:HE3	43:1:2144:C:OP1	2.20	0.41
25:h:88:LEU:HB3	25:h:92:MET:CG	2.51	0.41

Continued on next page...

Continued from previous page...

Atom-1	Atom-2	Interatomic distance (Å)	Clash overlap (Å)
30:f:107:PRO:HB2	30:f:110:GLU:OE1	2.20	0.41
35:c:99:ALA:HB1	35:c:103:ASP:HB2	2.02	0.41
43:1:1324:G:H2'	43:1:1325:C:C6	2.55	0.41
1:B:248:LYS:HB3	1:B:248:LYS:HE2	1.68	0.41
1:B:252:ILE:HG13	43:1:1880:G:H5'	2.03	0.41
3:C:269:ILE:HG23	3:C:270:GLU:N	2.35	0.41
7:H:77:PHE:O	7:H:81:THR:HG23	2.21	0.41
16:R:72:LEU:HD12	16:R:72:LEU:HA	1.80	0.41
16:R:102:LEU:HD22	16:R:138:LEU:HD22	2.03	0.41
32:k:18:ARG:HG3	32:k:18:ARG:NH1	2.35	0.41
39:A:5:ILE:N	39:A:5:ILE:HD13	2.34	0.41
43:1:148:C:O2'	43:1:149:C:H5'	2.21	0.41
43:1:1982:C:H2'	43:1:1983:C:C6	2.56	0.41
2:a:76:ASP:OD1	2:a:76:ASP:C	2.63	0.41
3:C:57:GLN:HG2	36:j:62:TYR:OH	2.21	0.41
3:C:179:ALA:HB2	43:1:1106:C:C5	2.55	0.41
3:C:304:LEU:HD12	3:C:304:LEU:HA	1.83	0.41
4:I:46:PHE:N	4:I:47:PRO:HD3	2.35	0.41
4:I:179:GLU:CD	4:I:179:GLU:H	2.29	0.41
5:p:52:CYS:O	5:p:68:ALA:HA	2.20	0.41
6:D:213:TYR:O	6:D:216:GLU:HG3	2.21	0.41
6:D:281:LYS:HE3	6:D:281:LYS:HB3	1.93	0.41
7:H:6:SER:HA	7:H:53:VAL:O	2.20	0.41
7:H:96:PRO:O	7:H:112:ASN:ND2	2.51	0.41
8:G:177:THR:HG22	8:G:178:SER:OG	2.21	0.41
8:G:201:HIS:C	8:G:201:HIS:ND1	2.77	0.41
12:M:105:THR:H	12:M:108:ASP:CG	2.29	0.41
19:P:10:ASN:OD1	19:P:10:ASN:C	2.64	0.41
19:P:51:LEU:HD12	19:P:51:LEU:HA	1.84	0.41
23:Z:91:ASP:OD1	23:Z:92:PHE:CD1	2.72	0.41
31:i:4:LYS:NZ	43:1:69:A:O2'	2.47	0.41
34:U:142:PHE:CD1	34:U:142:PHE:N	2.88	0.41
37:l:8:GLU:CD	37:l:8:GLU:H	2.28	0.41
43:1:1293:C:H3'	43:1:1294:C:C5	2.56	0.41
43:1:2074:U:OP2	49:1:2960:HOH:O	2.22	0.41
43:1:2318:C:OP2	43:1:2320:C:N4	2.52	0.41
43:1:2398:U:H3'	43:1:2399:U:C5'	2.51	0.41
9:J:108:GLU:OE1	9:J:111:ASP:N	2.52	0.41
19:P:3:LYS:HG2	42:4:13:G:OP1	2.21	0.41
24:b:10:LYS:HG3	49:1:4721:HOH:O	2.21	0.41
26:F:25:ALA:O	26:F:29:GLU:HG2	2.21	0.41

Continued on next page...

Continued from previous page...

Atom-1	Atom-2	Interatomic distance (Å)	Clash overlap (Å)
26:F:85:ARG:HG3	26:F:86:GLY:N	2.35	0.41
26:F:164:ILE:H	26:F:164:ILE:HG13	1.73	0.41
32:k:73:VAL:HG12	32:k:75:ASP:H	1.86	0.41
43:1:788:G:N2	43:1:791:C:OP2	2.49	0.41
43:1:1875:C:H2'	43:1:1876:A:C8	2.56	0.41
43:1:2097:C:C2	43:1:2098:G:N7	2.89	0.41
2:a:27:LYS:HE3	2:a:27:LYS:HB3	1.94	0.40
4:I:51:HIS:HB2	4:I:166:VAL:HG23	2.02	0.40
6:D:117:ILE:HG23	6:D:121:ALA:CB	2.51	0.40
6:D:268:LYS:HE2	6:D:268:LYS:HB2	1.86	0.40
8:G:153:LYS:HE2	8:G:153:LYS:HB2	1.85	0.40
11:L:194:LYS:HB2	11:L:194:LYS:HE2	1.82	0.40
17:T:2:THR:HG22	43:1:2048:G:N7	2.35	0.40
23:Z:94:SER:O	23:Z:97:THR:HG22	2.21	0.40
27:d:94:LEU:HD23	27:d:94:LEU:HA	1.85	0.40
43:1:427:C:H5'	43:1:428:G:OP2	2.20	0.40
43:1:1247:C:H2'	43:1:1248:C:C6	2.56	0.40
43:1:1437:G:OP2	43:1:1437:G:C8	2.74	0.40
43:1:1906:C:O2'	43:1:1907:U:O5'	2.39	0.40
43:1:2381:G:H2'	43:1:2382:U:C6	2.56	0.40
3:C:278:VAL:HG22	14:Q:130:PRO:HG3	2.03	0.40
6:D:41:LYS:HD2	6:D:41:LYS:HA	1.65	0.40
6:D:114:SER:OG	6:D:123:ALA:HB2	2.21	0.40
8:G:93:GLN:CD	8:G:94:ILE:HD13	2.46	0.40
8:G:134:ILE:HB	8:G:160:ILE:CD1	2.49	0.40
10:O:130:ARG:HH12	43:1:1013:C:H2'	1.86	0.40
10:O:180:GLU:O	10:O:186:GLN:NE2	2.54	0.40
17:T:75:GLN:HG2	17:T:88:ARG:HG2	2.03	0.40
17:T:79:ARG:HA	17:T:84:ILE:HD13	2.04	0.40
17:T:83:ARG:HG2	17:T:84:ILE:N	2.36	0.40
35:c:40:ASP:CB	35:c:42:LYS:HD3	2.51	0.40
41:3:113:G:O2'	41:3:114:A:O5'	2.39	0.40
43:1:246:G:O2'	43:1:247:A:H5'	2.20	0.40
43:1:454:G:H2'	43:1:455:C:C6	2.56	0.40
43:1:2348:C:H2'	43:1:2349:C:C6	2.56	0.40
2:a:85:GLU:OE1	2:a:85:GLU:N	2.40	0.40
7:H:21:LYS:O	7:H:22:ARG:HB2	2.22	0.40
8:G:90:ARG:HG3	8:G:94:ILE:HG12	2.03	0.40
8:G:119:ARG:O	8:G:123:LEU:HG	2.22	0.40
23:Z:33:ASN:CG	23:Z:34:GLU:N	2.78	0.40
26:F:225:LYS:HE2	26:F:225:LYS:HB2	1.91	0.40

Continued on next page...

Continued from previous page...

Atom-1	Atom-2	Interatomic distance (Å)	Clash overlap (Å)
34:U:85:TYR:CE2	34:U:133:PHE:HB2	2.56	0.40
39:A:118:GLU:HG3	39:A:126:LEU:HD21	2.03	0.40
43:1:2098:G:N1	43:1:2102:A:C2	2.88	0.40
43:1:2318:C:O2'	43:1:2319:G:H3'	2.22	0.40
2:a:96:THR:O	2:a:96:THR:CG2	2.70	0.40
3:C:158:ILE:O	3:C:162:VAL:HG22	2.21	0.40
4:I:46:PHE:CD1	4:I:141:ARG:HG3	2.57	0.40
7:H:92:TYR:CD1	7:H:92:TYR:C	2.99	0.40
8:G:164:LYS:HE3	8:G:164:LYS:HB2	1.88	0.40
12:M:114:LYS:O	12:M:118:GLU:HG3	2.21	0.40
13:N:145:ASP:OD1	13:N:145:ASP:C	2.63	0.40
16:R:158:GLU:O	16:R:161:GLN:NE2	2.55	0.40
23:Z:30:LEU:H	23:Z:30:LEU:CD2	2.34	0.40
33:o:64:LYS:HG2	43:1:2214:G:H5''	2.03	0.40
43:1:153:A:O2'	43:1:154:G:O5'	2.28	0.40
43:1:199:G:H2'	43:1:200:G:O4'	2.21	0.40
7:H:105:ASN:O	7:H:130:ILE:HG22	2.22	0.40
9:J:12:ILE:HG22	9:J:13:ARG:N	2.37	0.40
15:S:56:ARG:HH11	17:T:148:ILE:HG12	1.87	0.40
19:P:153:LYS:HG3	19:P:154:PRO:HD2	2.02	0.40
23:Z:47:LEU:HD23	23:Z:47:LEU:HA	1.95	0.40
30:f:38:THR:CG2	30:f:39:ARG:N	2.84	0.40
30:f:44:LYS:O	30:f:44:LYS:HG3	2.21	0.40

There are no symmetry-related clashes.

5.3 Torsion angles [i](#)

5.3.1 Protein backbone [i](#)

In the following table, the Percentiles column shows the percent Ramachandran outliers of the chain as a percentile score with respect to all PDB entries followed by that with respect to all EM entries.

The Analysed column shows the number of residues for which the backbone conformation was analysed, and the total number of residues.

Mol	Chain	Analysed	Favoured	Allowed	Outliers	Percentiles
1	B	376/379 (99%)	361 (96%)	15 (4%)	0	100 100
2	a	146/149 (98%)	141 (97%)	5 (3%)	0	100 100

Continued on next page...

Continued from previous page...

Mol	Chain	Analysed	Favoured	Allowed	Outliers	Percentiles	
3	C	311/316 (98%)	296 (95%)	15 (5%)	0	100	100
4	I	194/210 (92%)	182 (94%)	12 (6%)	0	100	100
5	p	91/94 (97%)	85 (93%)	6 (7%)	0	100	100
6	D	286/297 (96%)	274 (96%)	12 (4%)	0	100	100
7	H	181/185 (98%)	170 (94%)	11 (6%)	0	100	100
8	G	195/225 (87%)	185 (95%)	10 (5%)	0	100	100
9	J	155/173 (90%)	150 (97%)	5 (3%)	0	100	100
10	O	194/197 (98%)	192 (99%)	2 (1%)	0	100	100
11	L	200/234 (86%)	197 (98%)	3 (2%)	0	100	100
12	M	128/131 (98%)	123 (96%)	5 (4%)	0	100	100
13	N	201/204 (98%)	195 (97%)	6 (3%)	0	100	100
14	Q	177/179 (99%)	173 (98%)	4 (2%)	0	100	100
15	S	171/205 (83%)	164 (96%)	7 (4%)	0	100	100
16	R	182/196 (93%)	176 (97%)	6 (3%)	0	100	100
17	T	151/159 (95%)	148 (98%)	3 (2%)	0	100	100
18	V	135/142 (95%)	131 (97%)	4 (3%)	0	100	100
19	P	151/164 (92%)	145 (96%)	6 (4%)	0	100	100
20	X	114/141 (81%)	108 (95%)	6 (5%)	0	100	100
21	Y	133/135 (98%)	132 (99%)	1 (1%)	0	100	100
22	W	62/102 (61%)	61 (98%)	1 (2%)	0	100	100
23	Z	132/135 (98%)	123 (93%)	9 (7%)	0	100	100
24	b	55/62 (89%)	55 (100%)	0	0	100	100
25	h	120/124 (97%)	117 (98%)	3 (2%)	0	100	100
26	F	219/235 (93%)	212 (97%)	7 (3%)	0	100	100
27	d	93/106 (88%)	92 (99%)	1 (1%)	0	100	100
28	e	122/136 (90%)	116 (95%)	6 (5%)	0	100	100
29	g	95/120 (79%)	93 (98%)	2 (2%)	0	100	100
30	f	120/123 (98%)	112 (93%)	8 (7%)	0	100	100
31	i	79/90 (88%)	76 (96%)	3 (4%)	0	100	100
32	k	74/77 (96%)	70 (95%)	4 (5%)	0	100	100
33	o	91/106 (86%)	88 (97%)	3 (3%)	0	100	100

Continued on next page...

Continued from previous page...

Mol	Chain	Analysed	Favoured	Allowed	Outliers	Percentiles	
34	U	98/171 (57%)	89 (91%)	9 (9%)	0	100	100
35	c	97/109 (89%)	96 (99%)	1 (1%)	0	100	100
36	j	85/100 (85%)	83 (98%)	2 (2%)	0	100	100
37	l	48/51 (94%)	47 (98%)	1 (2%)	0	100	100
38	m	48/127 (38%)	45 (94%)	3 (6%)	0	100	100
39	A	246/251 (98%)	237 (96%)	9 (4%)	0	100	100
All	All	5756/6340 (91%)	5540 (96%)	216 (4%)	0	100	100

There are no Ramachandran outliers to report.

5.3.2 Protein sidechains [i](#)

In the following table, the Percentiles column shows the percent sidechain outliers of the chain as a percentile score with respect to all PDB entries followed by that with respect to all EM entries.

The Analysed column shows the number of residues for which the sidechain conformation was analysed, and the total number of residues.

Mol	Chain	Analysed	Rotameric	Outliers	Percentiles	
1	B	311/313 (99%)	310 (100%)	1 (0%)	86	94
2	a	126/127 (99%)	125 (99%)	1 (1%)	73	88
3	C	257/263 (98%)	251 (98%)	6 (2%)	44	72
4	I	166/177 (94%)	165 (99%)	1 (1%)	78	91
5	p	72/73 (99%)	70 (97%)	2 (3%)	38	66
6	D	233/242 (96%)	222 (95%)	11 (5%)	23	47
7	H	160/164 (98%)	153 (96%)	7 (4%)	25	50
8	G	174/198 (88%)	165 (95%)	9 (5%)	21	42
9	J	135/149 (91%)	130 (96%)	5 (4%)	30	57
10	O	164/165 (99%)	157 (96%)	7 (4%)	26	51
11	L	169/197 (86%)	168 (99%)	1 (1%)	78	91
12	M	109/111 (98%)	106 (97%)	3 (3%)	38	66
13	N	174/175 (99%)	169 (97%)	5 (3%)	37	65
14	Q	153/155 (99%)	151 (99%)	2 (1%)	61	82
15	S	154/182 (85%)	149 (97%)	5 (3%)	34	62

Continued on next page...

Continued from previous page...

Mol	Chain	Analysed	Rotameric	Outliers	Percentiles	
16	R	157/167 (94%)	154 (98%)	3 (2%)	50	76
17	T	127/133 (96%)	120 (94%)	7 (6%)	19	40
18	V	109/114 (96%)	103 (94%)	6 (6%)	19	40
19	P	129/139 (93%)	127 (98%)	2 (2%)	55	79
20	X	104/123 (85%)	101 (97%)	3 (3%)	37	65
21	Y	114/115 (99%)	107 (94%)	7 (6%)	17	35
22	W	57/92 (62%)	57 (100%)	0	100	100
23	Z	117/119 (98%)	108 (92%)	9 (8%)	12	25
24	b	52/57 (91%)	52 (100%)	0	100	100
25	h	105/107 (98%)	101 (96%)	4 (4%)	29	56
26	F	187/204 (92%)	178 (95%)	9 (5%)	23	46
27	d	85/92 (92%)	79 (93%)	6 (7%)	13	29
28	e	110/120 (92%)	106 (96%)	4 (4%)	31	58
29	g	86/100 (86%)	83 (96%)	3 (4%)	32	58
30	f	101/103 (98%)	95 (94%)	6 (6%)	18	37
31	i	71/78 (91%)	71 (100%)	0	100	100
32	k	66/68 (97%)	60 (91%)	6 (9%)	9	19
33	o	83/93 (89%)	80 (96%)	3 (4%)	31	58
34	U	88/153 (58%)	85 (97%)	3 (3%)	32	60
35	c	82/92 (89%)	80 (98%)	2 (2%)	43	70
36	j	72/83 (87%)	71 (99%)	1 (1%)	59	81
37	l	48/49 (98%)	48 (100%)	0	100	100
38	m	45/110 (41%)	42 (93%)	3 (7%)	15	31
39	A	186/192 (97%)	181 (97%)	5 (3%)	39	67
All	All	4938/5394 (92%)	4780 (97%)	158 (3%)	35	62

All (158) residues with a non-rotameric sidechain are listed below:

Mol	Chain	Res	Type
1	B	302	ASP
2	a	75	ILE
3	C	217	CYS
3	C	231	SER
3	C	250	VAL

Continued on next page...

Continued from previous page...

Mol	Chain	Res	Type
3	C	267	THR
3	C	268	ASP
3	C	307	LEU
4	I	125	THR
5	p	3	LYS
5	p	56	THR
6	D	28	THR
6	D	56	THR
6	D	65	THR
6	D	81	HIS
6	D	114	SER
6	D	115	VAL
6	D	140	ASP
6	D	196	PHE
6	D	199	SER
6	D	277	LEU
6	D	289	LEU
7	H	3	LEU
7	H	14	ASP
7	H	18	THR
7	H	20	ASN
7	H	46	HIS
7	H	142	LEU
7	H	150	VAL
8	G	53	VAL
8	G	64	ILE
8	G	92	LEU
8	G	111	LEU
8	G	112	VAL
8	G	149	THR
8	G	166	ASP
8	G	177	THR
8	G	191	THR
9	J	17	LEU
9	J	21	ILE
9	J	91	LEU
9	J	93	TYR
9	J	129	VAL
10	O	30	VAL
10	O	113	LYS
10	O	138	VAL
10	O	141	GLU

Continued on next page...

Continued from previous page...

Mol	Chain	Res	Type
10	O	167	ASP
10	O	186	GLN
10	O	194	LYS
11	L	36	SER
12	M	13	VAL
12	M	83	ILE
12	M	108	ASP
13	N	9	GLU
13	N	19	LEU
13	N	27	THR
13	N	187	SER
13	N	197	THR
14	Q	45	THR
14	Q	57	THR
15	S	77	SER
15	S	94	ILE
15	S	149	ASP
15	S	162	ASP
15	S	176	VAL
16	R	23	ARG
16	R	72	LEU
16	R	81	ARG
17	T	3	HIS
17	T	29	THR
17	T	63	THR
17	T	122	THR
17	T	144	ILE
17	T	146	SER
17	T	148	ILE
18	V	13	ASN
18	V	17	ILE
18	V	74	LEU
18	V	79	THR
18	V	123	VAL
18	V	130	ARG
19	P	35	ILE
19	P	52	ASN
20	X	54	SER
20	X	59	CYS
20	X	83	PHE
21	Y	24	GLU
21	Y	32	SER

Continued on next page...

Continued from previous page...

Mol	Chain	Res	Type
21	Y	38	LEU
21	Y	80	VAL
21	Y	86	LYS
21	Y	104	CYS
21	Y	111	MET
23	Z	16	GLN
23	Z	27	VAL
23	Z	37	SER
23	Z	44	ILE
23	Z	72	CYS
23	Z	91	ASP
23	Z	100	ASP
23	Z	121	GLU
23	Z	123	ARG
25	h	10	ILE
25	h	27	GLU
25	h	69	GLU
25	h	108	VAL
26	F	67	ASN
26	F	81	VAL
26	F	82	VAL
26	F	99	SER
26	F	138	THR
26	F	159	VAL
26	F	165	ASP
26	F	209	ASP
26	F	231	VAL
27	d	8	THR
27	d	38	LEU
27	d	42	GLU
27	d	50	VAL
27	d	87	ASP
27	d	89	GLU
28	e	47	MET
28	e	82	SER
28	e	109	SER
28	e	128	ASP
29	g	7	THR
29	g	25	ARG
29	g	94	GLU
30	f	36	ILE
30	f	44	LYS

Continued on next page...

Continued from previous page...

Mol	Chain	Res	Type
30	f	64	LYS
30	f	81	THR
30	f	92	VAL
30	f	120	VAL
32	k	9	ASN
32	k	36	VAL
32	k	42	THR
32	k	48	THR
32	k	50	THR
32	k	59	SER
33	o	7	GLU
33	o	19	THR
33	o	74	SER
34	U	62	ASN
34	U	70	SER
34	U	97	HIS
35	c	47	PHE
35	c	103	ASP
36	j	76	SER
38	m	78	MET
38	m	81	THR
38	m	124	SER
39	A	7	VAL
39	A	84	THR
39	A	102	LEU
39	A	146	THR
39	A	223	SER

Sometimes sidechains can be flipped to improve hydrogen bonding and reduce clashes. All (43) such sidechains are listed below:

Mol	Chain	Res	Type
1	B	109	HIS
1	B	214	GLN
1	B	256	HIS
1	B	259	ASN
1	B	318	GLN
1	B	347	ASN
2	a	66	ASN
4	I	195	ASN
7	H	46	HIS
8	G	48	GLN
8	G	172	HIS

Continued on next page...

Continued from previous page...

Mol	Chain	Res	Type
8	G	185	ASN
9	J	20	ASN
9	J	68	HIS
11	L	98	GLN
13	N	74	GLN
14	Q	87	ASN
14	Q	134	ASN
15	S	63	ASN
15	S	97	ASN
16	R	99	GLN
17	T	54	HIS
17	T	133	ASN
18	V	13	ASN
18	V	39	ASN
19	P	52	ASN
19	P	103	HIS
21	Y	62	HIS
21	Y	85	GLN
21	Y	112	ASN
22	W	5	ASN
24	b	7	HIS
26	F	167	GLN
30	f	24	GLN
30	f	54	HIS
31	i	82	GLN
34	U	93	ASN
35	c	33	GLN
35	c	37	ASN
36	j	86	ASN
38	m	109	ASN
39	A	32	ASN
39	A	187	HIS

5.3.3 RNA [i](#)

Mol	Chain	Analysed	Backbone Outliers	Pucker Outliers
41	3	116/120 (96%)	19 (16%)	1 (0%)
42	4	140/141 (99%)	26 (18%)	1 (0%)
43	1	2544/2687 (94%)	353 (13%)	21 (0%)
All	All	2800/2948 (94%)	398 (14%)	23 (0%)

All (398) RNA backbone outliers are listed below:

Mol	Chain	Res	Type
41	3	10	A
41	3	12	C
41	3	22	A
41	3	28	C
41	3	36	G
41	3	37	U
41	3	38	U
41	3	40	C
41	3	42	A
41	3	53	G
41	3	54	A
41	3	64	A
41	3	75	G
41	3	76	U
41	3	85	C
41	3	92	G
41	3	100	A
41	3	110	G
41	3	115	A
42	4	3	C
42	4	9	G
42	4	13	G
42	4	17	A
42	4	23	C
42	4	27	C
42	4	34	G
42	4	35	C
42	4	38	C
42	4	59	A
42	4	62	C
42	4	63	G
42	4	73	C
42	4	75	C
42	4	84	C
42	4	85	G
42	4	86	A
42	4	87	G
42	4	90	G
42	4	101	C
42	4	103	A
42	4	105	C
42	4	116	C
42	4	118	G

Continued on next page...

Continued from previous page...

Mol	Chain	Res	Type
42	4	119	G
42	4	120	C
43	1	4	G
43	1	23	G
43	1	38	A
43	1	41	A
43	1	47	G
43	1	57	G
43	1	58	A
43	1	63	A
43	1	64	A
43	1	66	C
43	1	68	A
43	1	72	G
43	1	73	G
43	1	75	A
43	1	83	U
43	1	88	G
43	1	121	G
43	1	126	G
43	1	131	G
43	1	132	C
43	1	134	C
43	1	153	A
43	1	154	G
43	1	161	C
43	1	175	G
43	1	184	C
43	1	220	A
43	1	238	U
43	1	247	A
43	1	248	A
43	1	249	G
43	1	254	G
43	1	255	C
43	1	279	G
43	1	300	C
43	1	302	A
43	1	326	G
43	1	328	A
43	1	335	G
43	1	336	C

Continued on next page...

Continued from previous page...

Mol	Chain	Res	Type
43	1	347	A
43	1	348	A
43	1	349	G
43	1	350	A
43	1	373	C
43	1	374	C
43	1	375	C
43	1	376	G
43	1	382	C
43	1	394	C
43	1	395	A
43	1	406	A
43	1	407	G
43	1	423	A
43	1	427	C
43	1	428	G
43	1	433	A
43	1	434	G
43	1	435	C
43	1	436	C
43	1	441	C
43	1	442	G
43	1	458	G
43	1	462	C
43	1	467	G
43	1	481	C
43	1	484	C
43	1	489	G
43	1	495	G
43	1	500	G
43	1	515	G
43	1	530	G
43	1	532	U
43	1	552	G
43	1	564	G
43	1	576	C
43	1	582	G
43	1	589	U
43	1	594	C
43	1	610	G
43	1	611	A
43	1	612	G

Continued on next page...

Continued from previous page...

Mol	Chain	Res	Type
43	1	622	G
43	1	629	A
43	1	631	G
43	1	632	A
43	1	636	A
43	1	638	C
43	1	640	A
43	1	652	G
43	1	659	G
43	1	674	C
43	1	675	C
43	1	693	C
43	1	707	G
43	1	721	G
43	1	725	G
43	1	726	G
43	1	744	U
43	1	746	G
43	1	748	C
43	1	758	A
43	1	774	G
43	1	775	C
43	1	786	C
43	1	806	G
43	1	807	A
43	1	812	G
43	1	825	G
43	1	839	G
43	1	852	G
43	1	861	A
43	1	863	C
43	1	889	C
43	1	896	C
43	1	899	G
43	1	907	G
43	1	915	G
43	1	920	G
43	1	983	G
43	1	985	A
43	1	1000	A
43	1	1001	A
43	1	1002	A

Continued on next page...

Continued from previous page...

Mol	Chain	Res	Type
43	1	1003	U
43	1	1005	G
43	1	1006	A
43	1	1007	G
43	1	1014	G
43	1	1015	G
43	1	1028	G
43	1	1029	C
43	1	1030	G
43	1	1043	G
43	1	1051	G
43	1	1071	C
43	1	1073	G
43	1	1079	G
43	1	1108	G
43	1	1120	G
43	1	1123	C
43	1	1138	C
43	1	1148	C
43	1	1149	G
43	1	1150	C
43	1	1164	G
43	1	1165	G
43	1	1166	G
43	1	1212	G
43	1	1218	G
43	1	1231	A
43	1	1235	G
43	1	1236	G
43	1	1237	A
43	1	1240	G
43	1	1244	G
43	1	1246	G
43	1	1251	C
43	1	1256	C
43	1	1259	A
43	1	1260	C
43	1	1265	A
43	1	1274	A
43	1	1294	C
43	1	1295	C
43	1	1298	C

Continued on next page...

Continued from previous page...

Mol	Chain	Res	Type
43	1	1304	C
43	1	1307	C
43	1	1308	C
43	1	1310	C
43	1	1321	C
43	1	1352	G
43	1	1366	C
43	1	1370	A
43	1	1379	A
43	1	1380	C
43	1	1387	C
43	1	1391	G
43	1	1404	G
43	1	1413	C
43	1	1415	C
43	1	1434	C
43	1	1437	G
43	1	1438	A
43	1	1453	C
43	1	1454	C
43	1	1455	G
43	1	1460	C
43	1	1471	G
43	1	1472	A
43	1	1480	A
43	1	1496	C
43	1	1508	C
43	1	1509	G
43	1	1516	A
43	1	1536	G
43	1	1580	C
43	1	1588	G
43	1	1598	G
43	1	1599	A
43	1	1600	A
43	1	1609	G
43	1	1618	A
43	1	1627	U
43	1	1630	A
43	1	1645	A
43	1	1646	G
43	1	1674	A

Continued on next page...

Continued from previous page...

Mol	Chain	Res	Type
43	1	1691	C
43	1	1692	G
43	1	1694	C
43	1	1695	C
43	1	1711	U
43	1	1732	G
43	1	1735	G
43	1	1742	A
43	1	1758	G
43	1	1759	G
43	1	1766	A
43	1	1784	U
43	1	1793	G
43	1	1796	U
43	1	1799	A
43	1	1801	G
43	1	1820	U
43	1	1821	G
43	1	1822	U
43	1	1849	A
43	1	1859	A
43	1	1860	C
43	1	1861	G
43	1	1864	C
43	1	1871	C
43	1	1879	G
43	1	1883	C
43	1	1887	A
43	1	1888	A
43	1	1889	G
43	1	1890	A
43	1	1896	U
43	1	1897	U
43	1	1906	C
43	1	1907	U
43	1	1982	C
43	1	1983	C
43	1	1984	G
43	1	1985	C
43	1	1987	G
43	1	1988	C
43	1	1998	C

Continued on next page...

Continued from previous page...

Mol	Chain	Res	Type
43	1	2008	C
43	1	2010	C
43	1	2011	G
43	1	2015	A
43	1	2016	C
43	1	2028	G
43	1	2029	G
43	1	2036	G
43	1	2048	G
43	1	2049	C
43	1	2074	U
43	1	2077	C
43	1	2078	A
43	1	2079	C
43	1	2097	C
43	1	2098	G
43	1	2099	G
43	1	2102	A
43	1	2103	C
43	1	2111	G
43	1	2113	A
43	1	2118	A
43	1	2126	A
43	1	2136	G
43	1	2138	C
43	1	2150	G
43	1	2151	U
43	1	2174	G
43	1	2175	G
43	1	2176	G
43	1	2177	C
43	1	2184	A
43	1	2198	C
43	1	2199	G
43	1	2217	G
43	1	2221	G
43	1	2222	A
43	1	2231	C
43	1	2235	G
43	1	2237	G
43	1	2238	A
43	1	2264	C

Continued on next page...

Continued from previous page...

Mol	Chain	Res	Type
43	1	2265	C
43	1	2266	G
43	1	2292	G
43	1	2294	U
43	1	2296	U
43	1	2308	A
43	1	2319	G
43	1	2320	C
43	1	2344	U
43	1	2354	C
43	1	2355	A
43	1	2356	A
43	1	2362	C
43	1	2363	G
43	1	2367	G
43	1	2391	A
43	1	2398	U
43	1	2399	U
43	1	2403	C
43	1	2414	C
43	1	2415	C
43	1	2428	C
43	1	2429	G
43	1	2445	A
43	1	2446	G
43	1	2465	G
43	1	2497	C
43	1	2503	G
43	1	2513	G
43	1	2514	G
43	1	2530	G
43	1	2533	U
43	1	2536	A
43	1	2542	G
43	1	2544	A
43	1	2545	C
43	1	2566	G
43	1	2571	G
43	1	2573	G
43	1	2578	A
43	1	2579	G
43	1	2582	C

Continued on next page...

Continued from previous page...

Mol	Chain	Res	Type
43	1	2585	U
43	1	2591	G
43	1	2592	U
43	1	2607	C
43	1	2608	G
43	1	2626	G
43	1	2627	C
43	1	2637	C
43	1	2646	G
43	1	2647	C
43	1	2648	A
43	1	2651	G
43	1	2655	U
43	1	2656	G
43	1	2666	G
43	1	2672	C
43	1	2678	U
43	1	2684	G
43	1	2685	C

All (23) RNA pucker outliers are listed below:

Mol	Chain	Res	Type
41	3	75	G
42	4	16	G
43	1	174	C
43	1	334	U
43	1	347	A
43	1	375	C
43	1	434	G
43	1	631	G
43	1	1014	G
43	1	1165	G
43	1	1293	C
43	1	1365	C
43	1	1414	C
43	1	1436	U
43	1	1599	A
43	1	1645	A
43	1	2176	G
43	1	2319	G
43	1	2353	U

Continued on next page...

Continued from previous page...

Mol	Chain	Res	Type
43	1	2354	C
43	1	2535	U
43	1	2565	G
43	1	2581	C

5.4 Non-standard residues in protein, DNA, RNA chains [i](#)

There are no non-standard protein/DNA/RNA residues in this entry.

5.5 Carbohydrates [i](#)

There are no oligosaccharides in this entry.

5.6 Ligand geometry [i](#)

Of 192 ligands modelled in this entry, 191 are monoatomic - leaving 1 for Mogul analysis.

In the following table, the Counts columns list the number of bonds (or angles) for which Mogul statistics could be retrieved, the number of bonds (or angles) that are observed in the model and the number of bonds (or angles) that are defined in the Chemical Component Dictionary. The Link column lists molecule types, if any, to which the group is linked. The Z score for a bond length (or angle) is the number of standard deviations the observed value is removed from the expected value. A bond length (or angle) with $|Z| > 2$ is considered an outlier worth inspection. RMSZ is the root-mean-square of all Z scores of the bond lengths (or angles).

Mol	Type	Chain	Res	Link	Bond lengths			Bond angles		
					Counts	RMSZ	$\# Z > 2$	Counts	RMSZ	$\# Z > 2$
48	SPD	1	2701	-	9,9,9	0.31	0	8,8,8	0.89	0

In the following table, the Chirals column lists the number of chiral outliers, the number of chiral centers analysed, the number of these observed in the model and the number defined in the Chemical Component Dictionary. Similar counts are reported in the Torsion and Rings columns. '-' means no outliers of that kind were identified.

Mol	Type	Chain	Res	Link	Chirals	Torsions	Rings
48	SPD	1	2701	-	-	3/7/7/7	-

There are no bond length outliers.

There are no bond angle outliers.

There are no chirality outliers.

All (3) torsion outliers are listed below:

Mol	Chain	Res	Type	Atoms
48	1	2701	SPD	C3-C4-C5-N6
48	1	2701	SPD	C2-C3-C4-C5
48	1	2701	SPD	N1-C2-C3-C4

There are no ring outliers.

No monomer is involved in short contacts.

5.7 Other polymers [i](#)

There are no such residues in this entry.

5.8 Polymer linkage issues [i](#)

There are no chain breaks in this entry.

6 Map visualisation [i](#)

This section contains visualisations of the EMDB entry EMD-29407. These allow visual inspection of the internal detail of the map and identification of artifacts.

Images derived from a raw map, generated by summing the deposited half-maps, are presented below the corresponding image components of the primary map to allow further visual inspection and comparison with those of the primary map.

6.1 Orthogonal projections [i](#)

6.1.1 Primary map

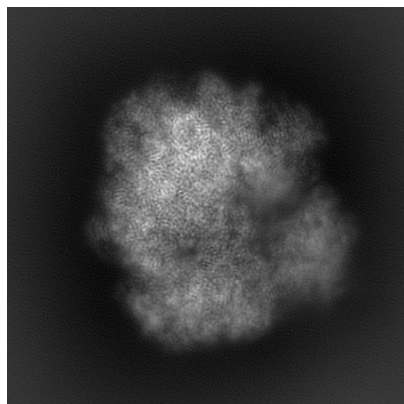

X

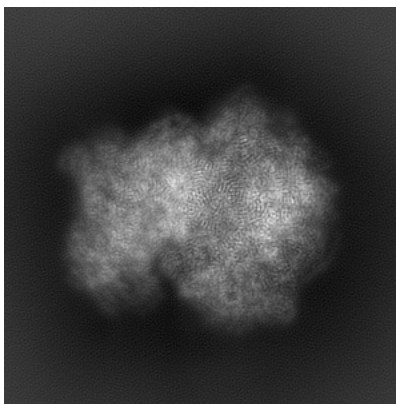

Y

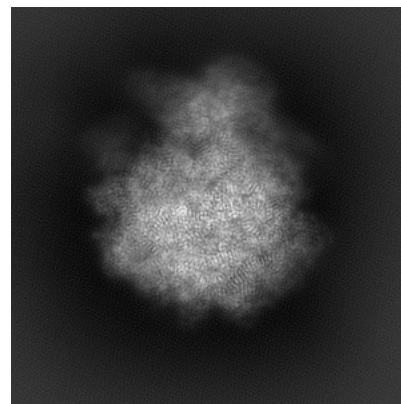

Z

6.1.2 Raw map

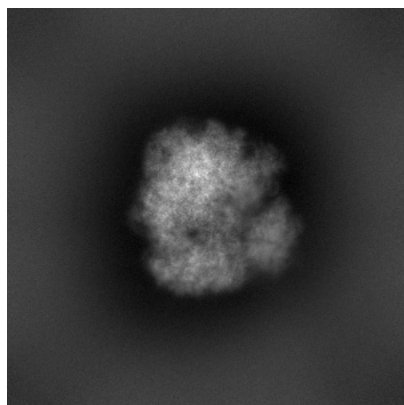

X

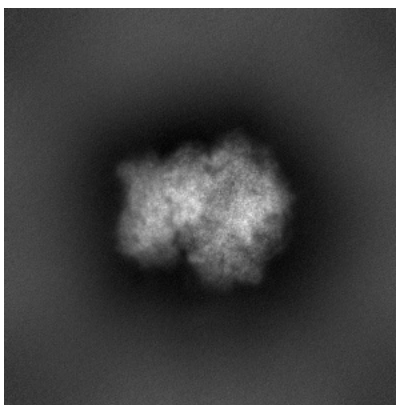

Y

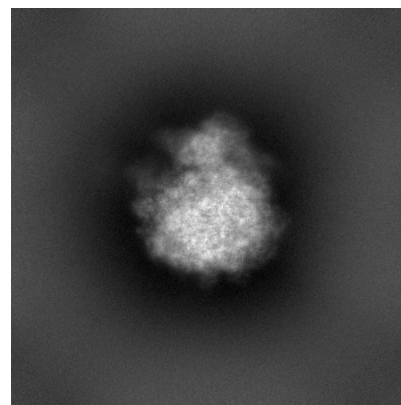

Z

The images above show the map projected in three orthogonal directions.

6.2 Central slices [i](#)

6.2.1 Primary map

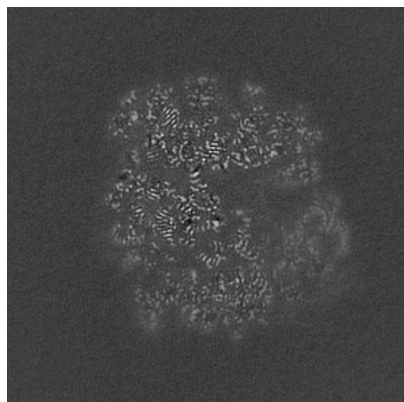

X Index: 225

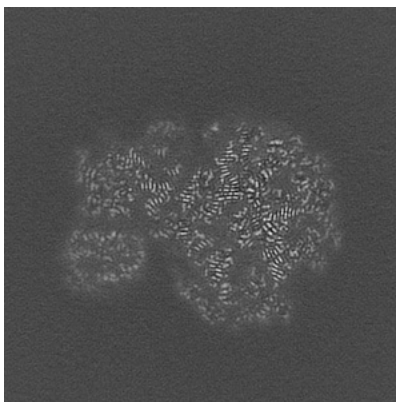

Y Index: 225

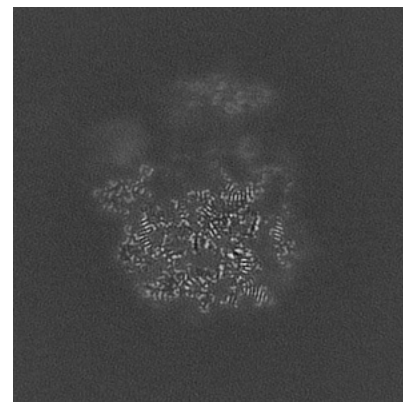

Z Index: 225

6.2.2 Raw map

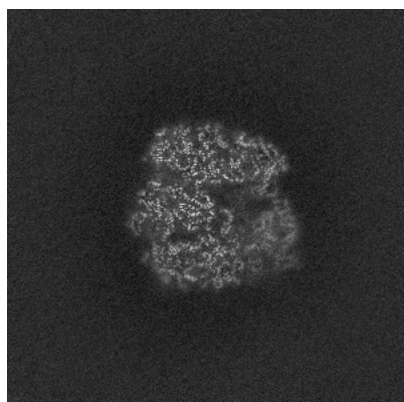

X Index: 351

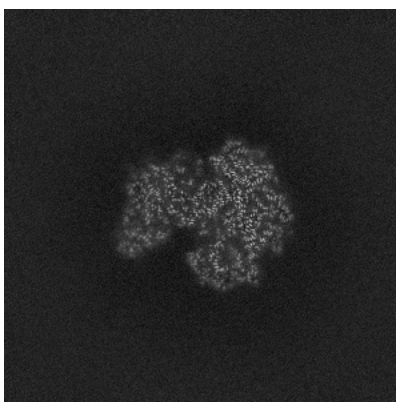

Y Index: 351

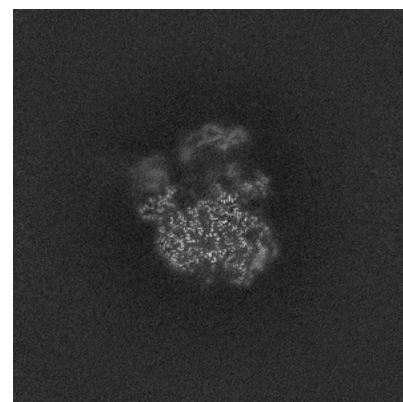

Z Index: 351

The images above show central slices of the map in three orthogonal directions.

6.3 Largest variance slices [i](#)

6.3.1 Primary map

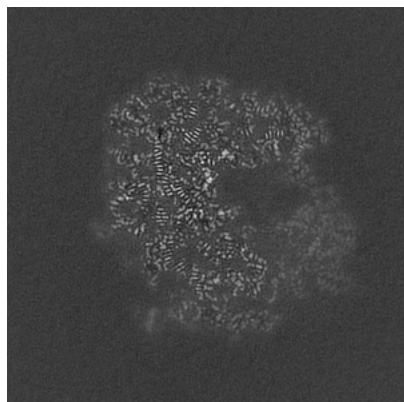

X Index: 239

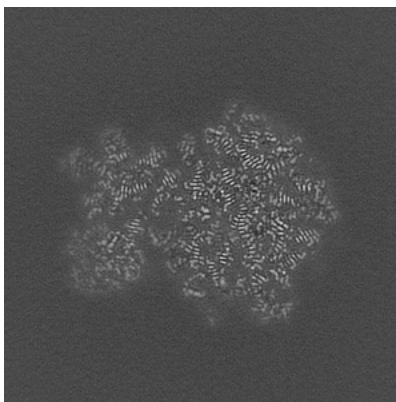

Y Index: 217

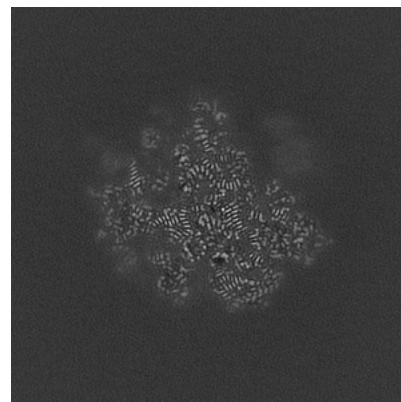

Z Index: 280

6.3.2 Raw map

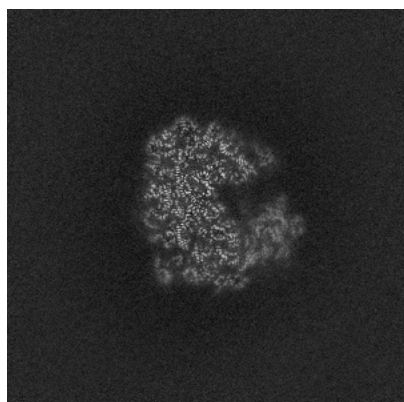

X Index: 371

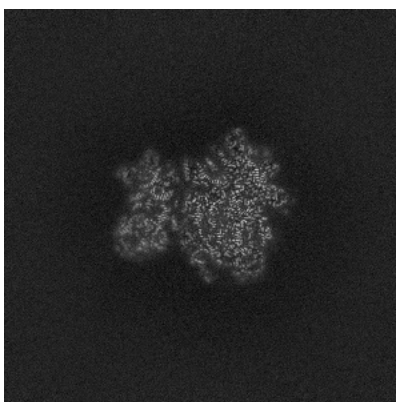

Y Index: 332

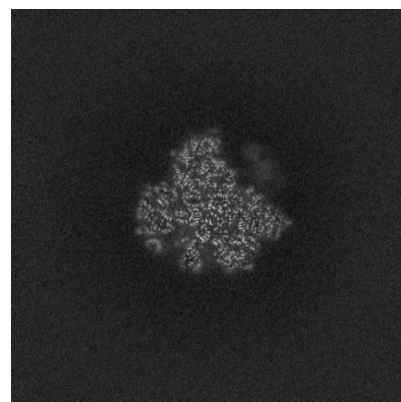

Z Index: 417

The images above show the largest variance slices of the map in three orthogonal directions.

6.4 Orthogonal standard-deviation projections (False-color) [i](#)

6.4.1 Primary map

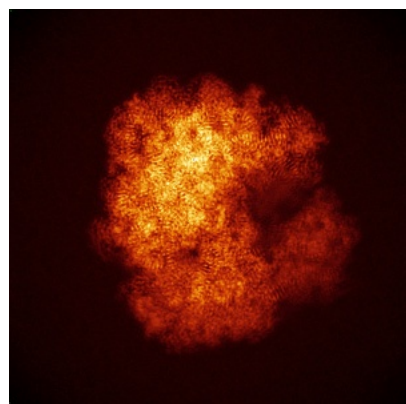

X

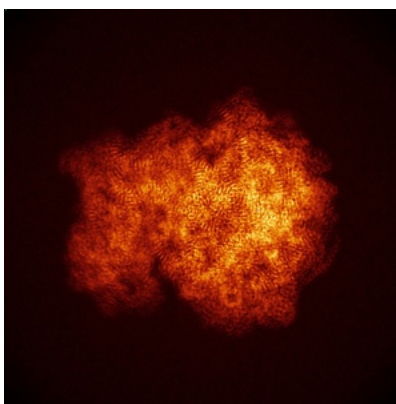

Y

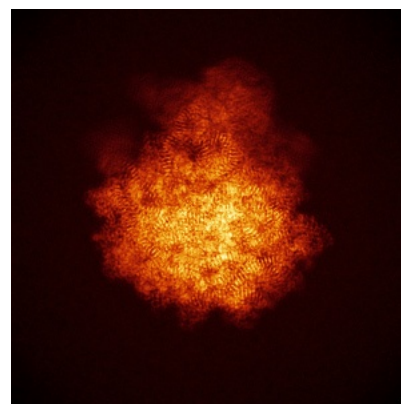

Z

6.4.2 Raw map

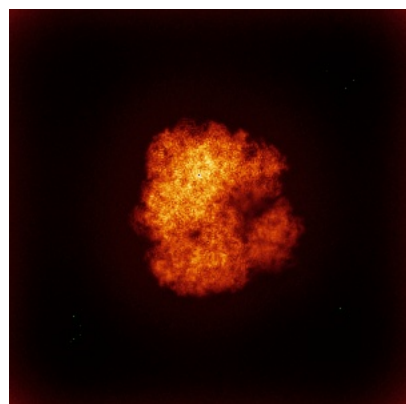

X

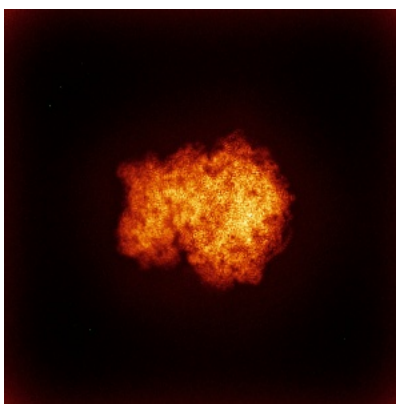

Y

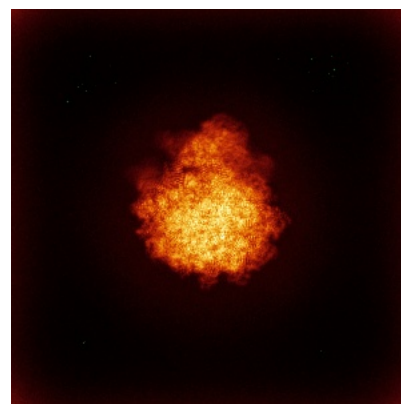

Z

The images above show the map standard deviation projections with false color in three orthogonal directions. Minimum values are shown in green, max in blue, and dark to light orange shades represent small to large values respectively.

6.5 Orthogonal surface views [i](#)

6.5.1 Primary map

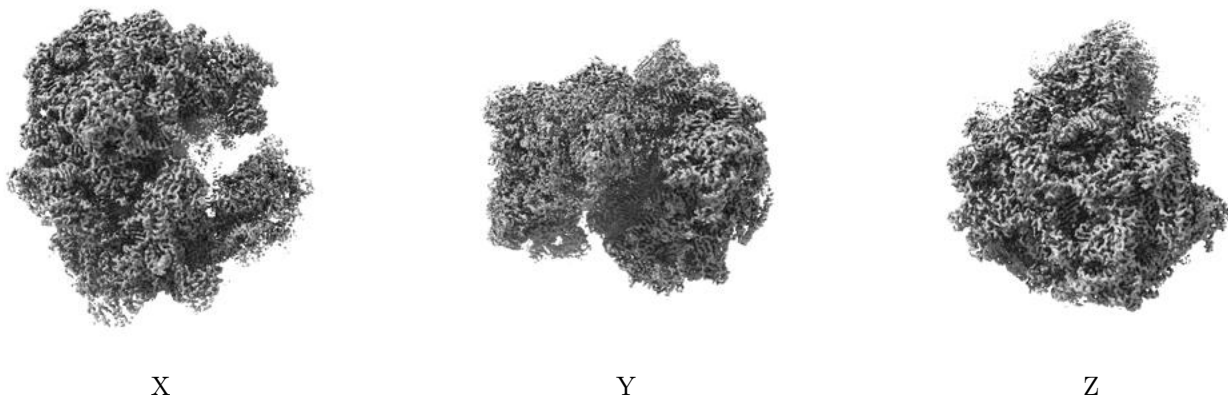

The images above show the 3D surface view of the map at the recommended contour level 0.461. These images, in conjunction with the slice images, may facilitate assessment of whether an appropriate contour level has been provided.

6.5.2 Raw map



These images show the 3D surface of the raw map. The raw map's contour level was selected so that its surface encloses the same volume as the primary map does at its recommended contour level.

6.6 Mask visualisation [i](#)

This section was not generated. No masks/segmentation were deposited.

7 Map analysis [i](#)

This section contains the results of statistical analysis of the map.

7.1 Map-value distribution [i](#)

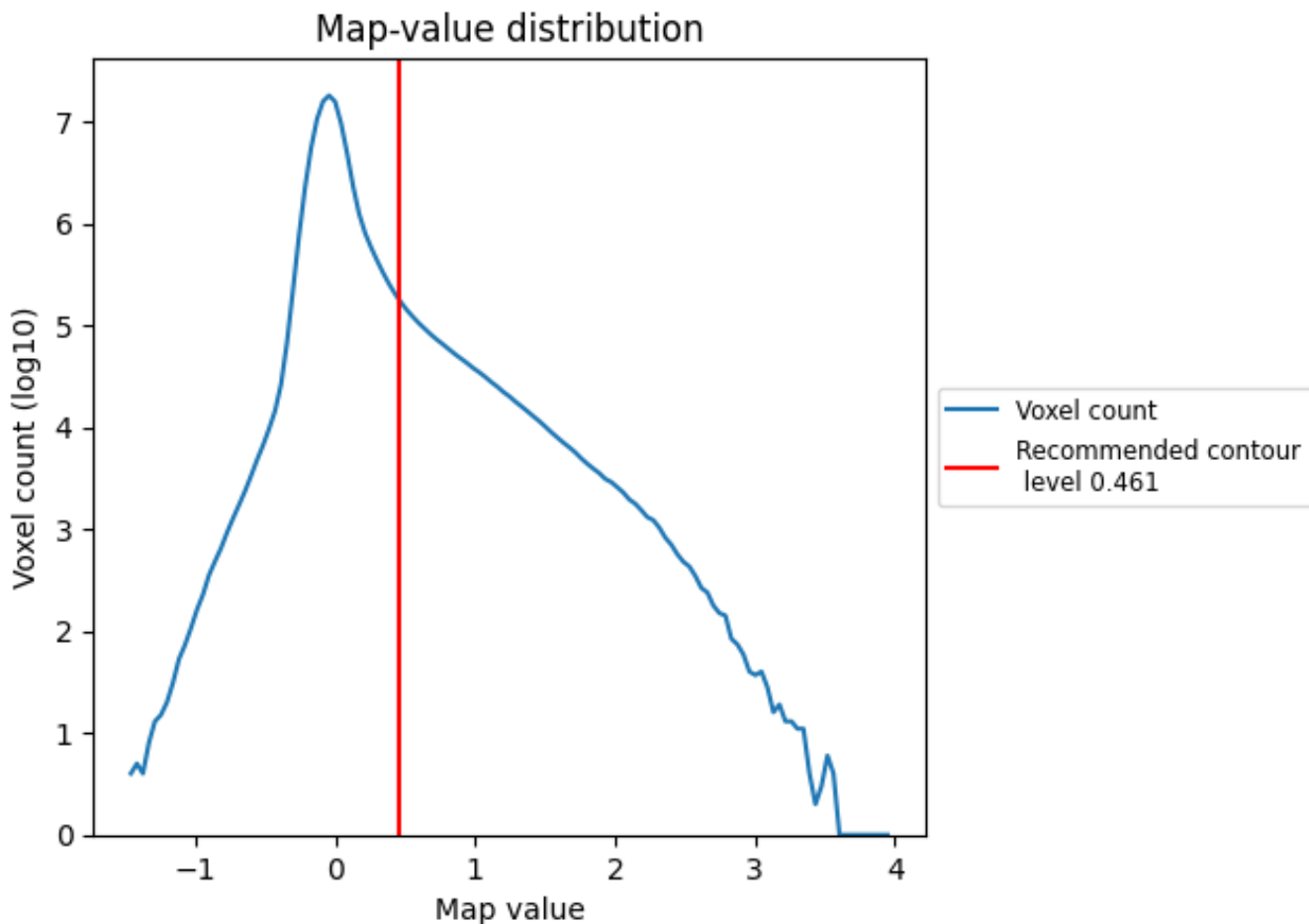

The map-value distribution is plotted in 128 intervals along the x-axis. The y-axis is logarithmic. A spike in this graph at zero usually indicates that the volume has been masked.

7.2 Volume estimate [i](#)

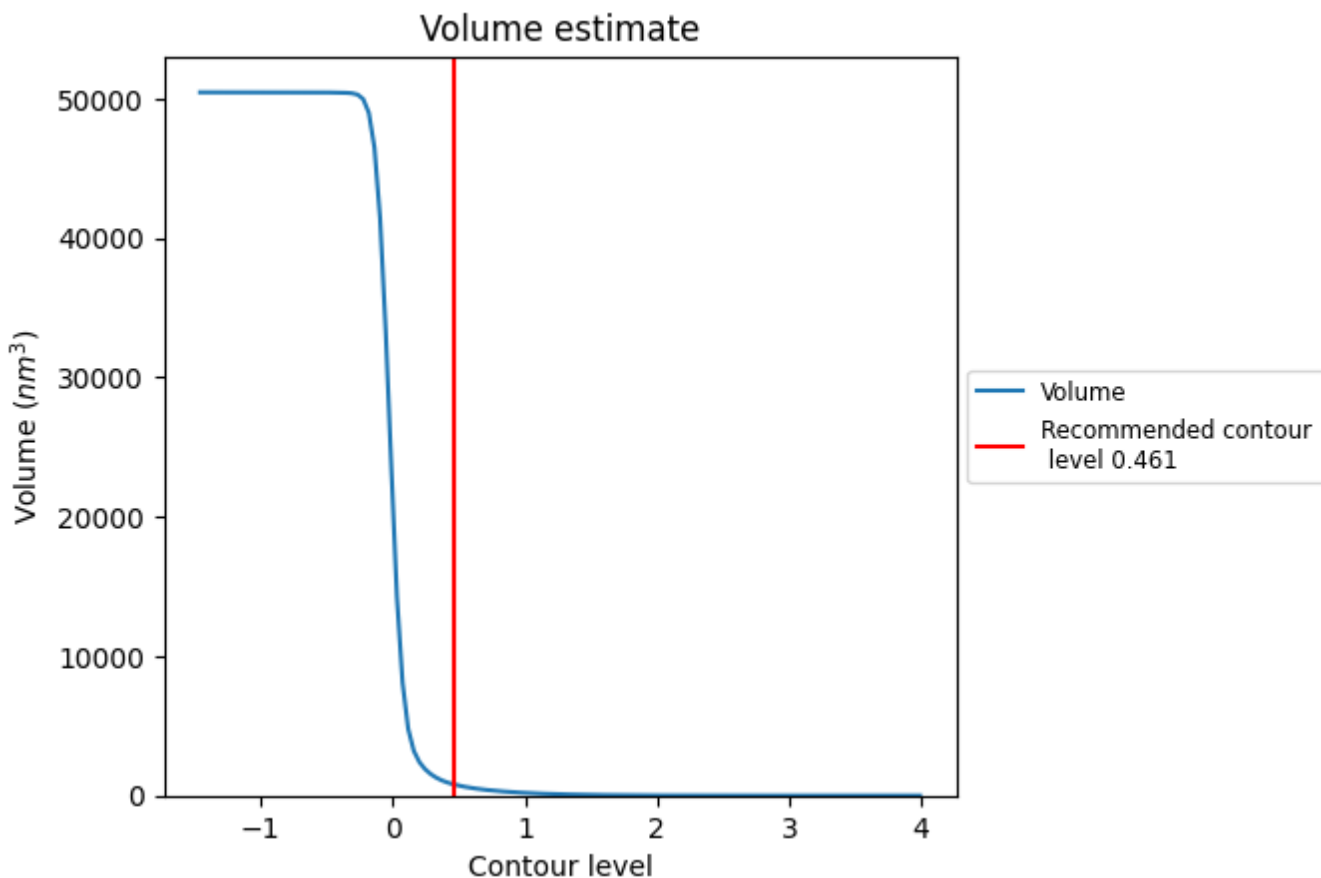

The volume at the recommended contour level is 802 nm³; this corresponds to an approximate mass of 725 kDa.

The volume estimate graph shows how the enclosed volume varies with the contour level. The recommended contour level is shown as a vertical line and the intersection between the line and the curve gives the volume of the enclosed surface at the given level.

7.3 Rotationally averaged power spectrum i

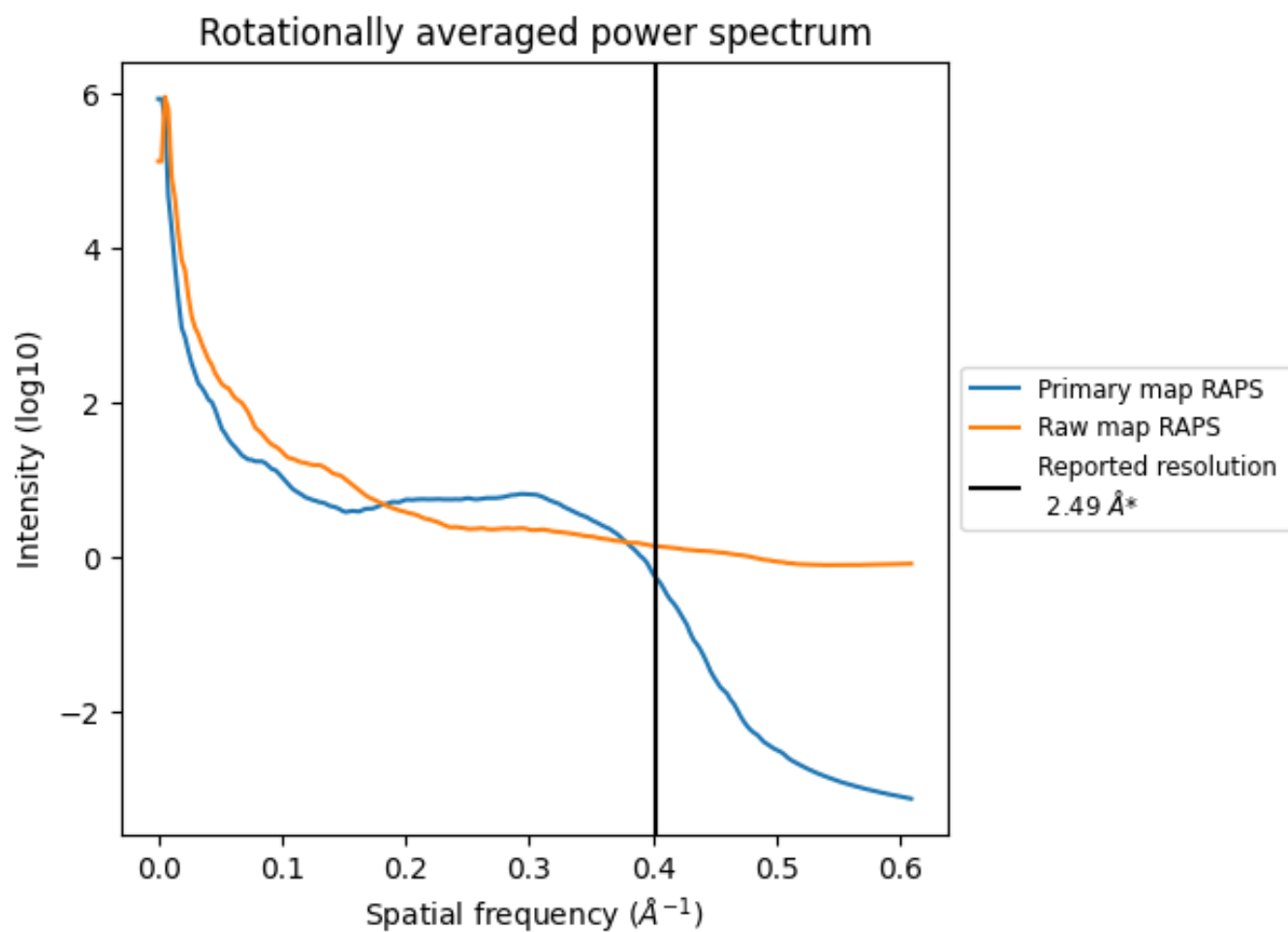

*Reported resolution corresponds to spatial frequency of 0.402 Å⁻¹

8 Fourier-Shell correlation [i](#)

Fourier-Shell Correlation (FSC) is the most commonly used method to estimate the resolution of single-particle and subtomogram-averaged maps. The shape of the curve depends on the imposed symmetry, mask and whether or not the two 3D reconstructions used were processed from a common reference. The reported resolution is shown as a black line. A curve is displayed for the half-bit criterion in addition to lines showing the 0.143 gold standard cut-off and 0.5 cut-off.

8.1 FSC [i](#)

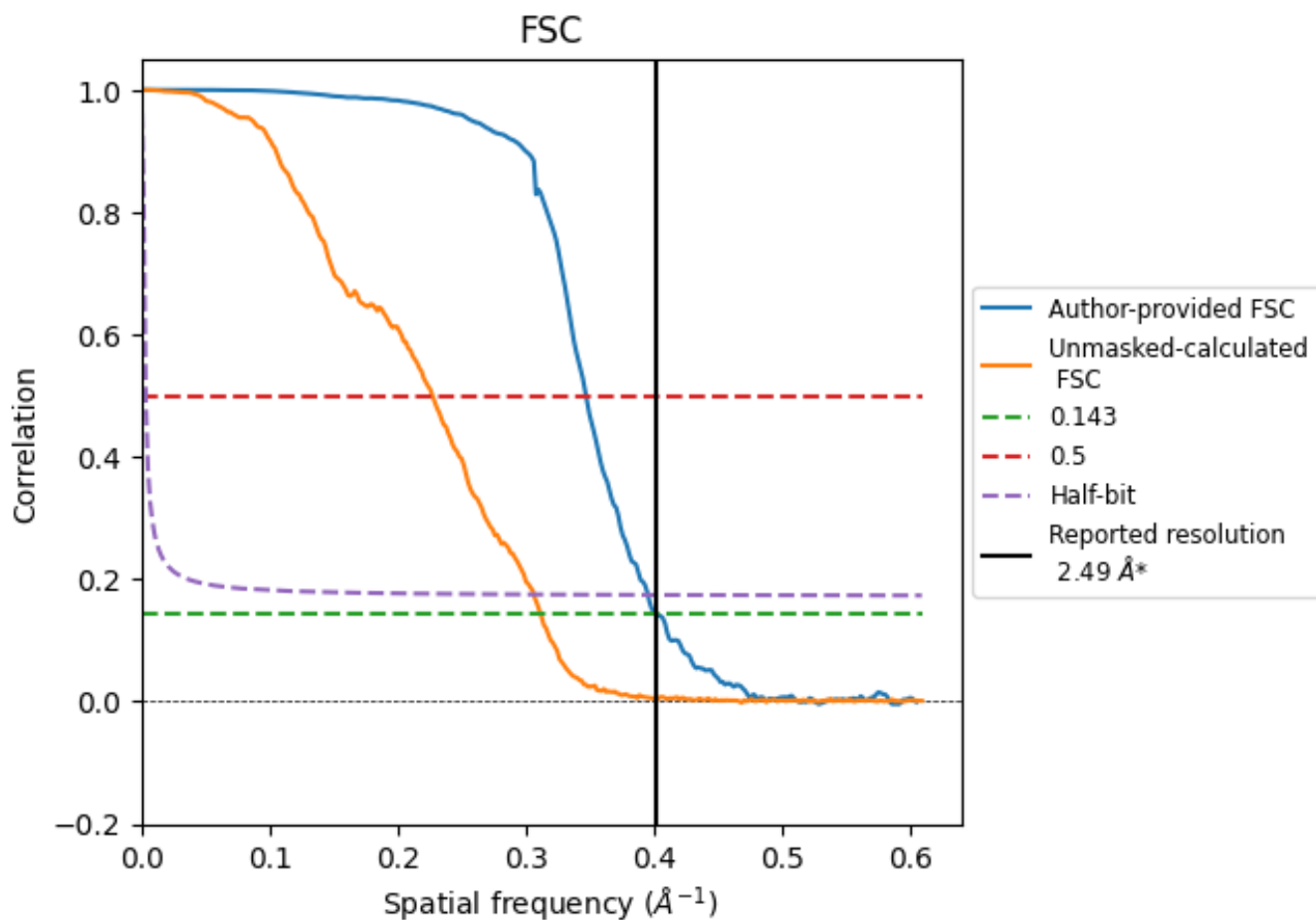

*Reported resolution corresponds to spatial frequency of 0.402 Å⁻¹

8.2 Resolution estimates [i](#)

Resolution estimate (Å)	Estimation criterion (FSC cut-off)		
	0.143	0.5	Half-bit
Reported by author	2.49	-	-
Author-provided FSC curve	2.49	2.88	2.53
Unmasked-calculated*	3.21	4.40	3.27

*Resolution estimate based on FSC curve calculated by comparison of deposited half-maps. The value from deposited half-maps intersecting FSC 0.143 CUT-OFF 3.21 differs from the reported value 2.49 by more than 10 %

9 Map-model fit [i](#)

This section contains information regarding the fit between EMD map EMD-29407 and PDB model 8FRU. Per-residue inclusion information can be found in section 3 on page 15.

9.1 Map-model overlay [i](#)

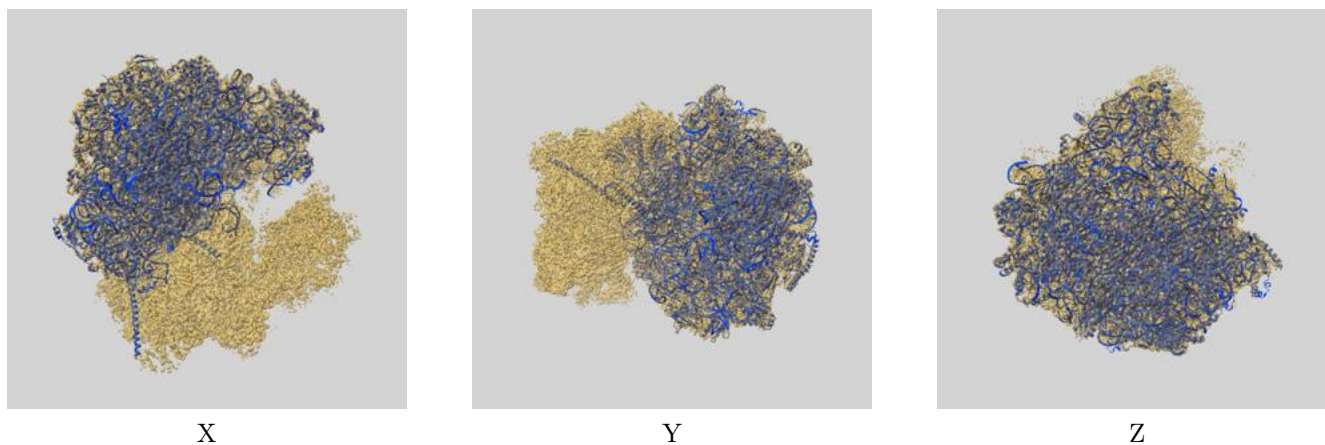

The images above show the 3D surface view of the map at the recommended contour level 0.461 at 50% transparency in yellow overlaid with a ribbon representation of the model coloured in blue. These images allow for the visual assessment of the quality of fit between the atomic model and the map.

9.2 Q-score mapped to coordinate model [i](#)

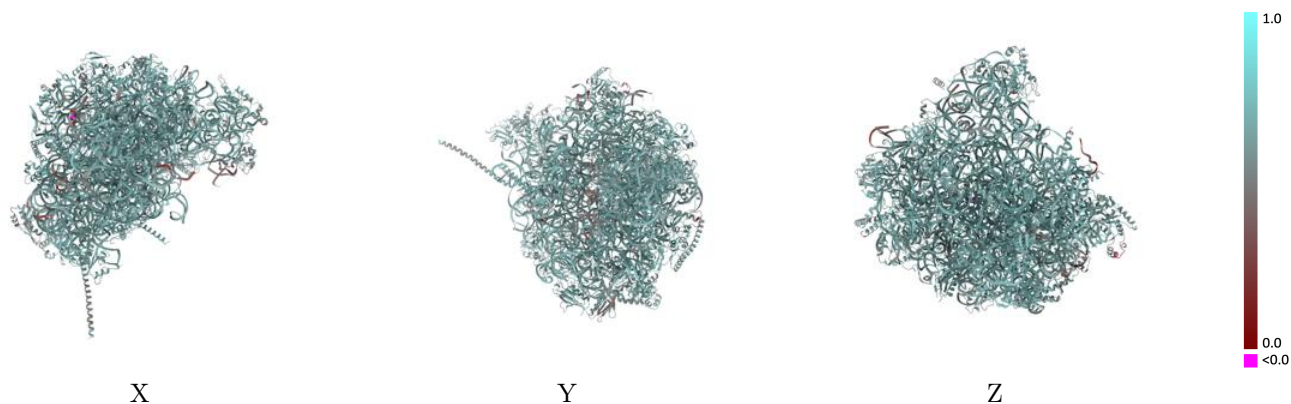

The images above show the model with each residue coloured according to its Q-score. This shows their resolvability in the map with higher Q-score values reflecting better resolvability. Please note: Q-score is calculating the resolvability of atoms, and thus high values are only expected at resolutions at which atoms can be resolved. Low Q-score values may therefore be expected for many entries.

9.3 Atom inclusion mapped to coordinate model [i](#)

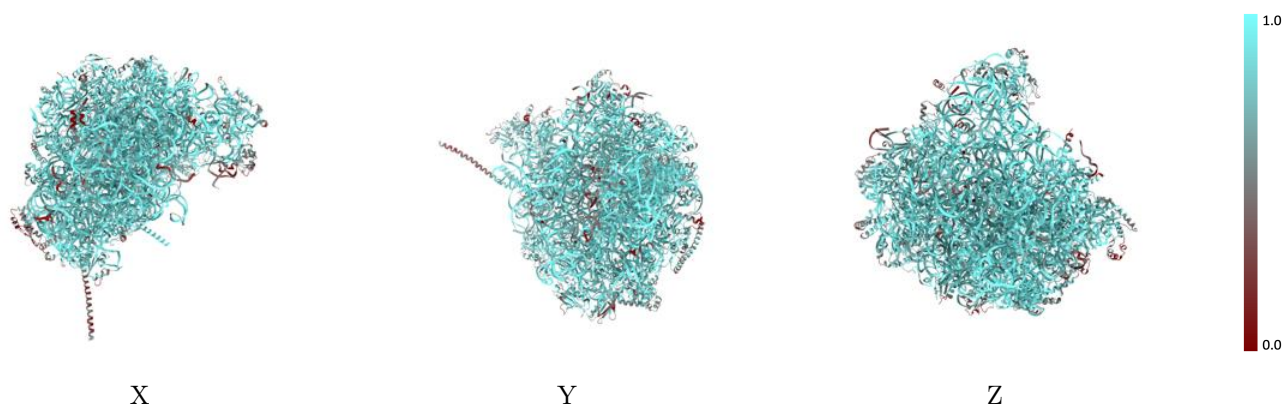

The images above show the model with each residue coloured according to its atom inclusion. This shows to what extent they are inside the map at the recommended contour level (0.461).



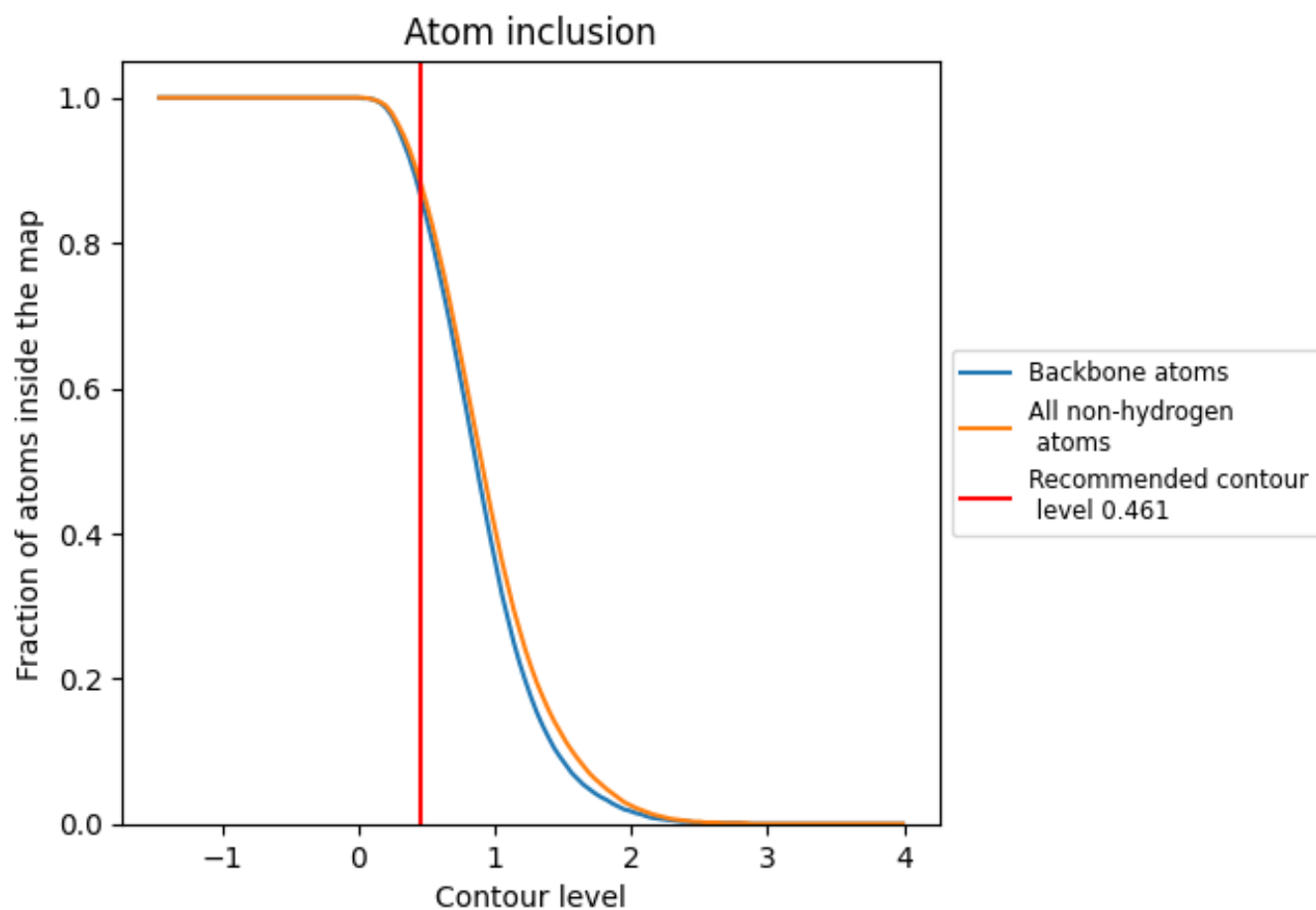



































































9.4 Atom inclusion [i](#)



At the recommended contour level, 86% of all backbone atoms, 88% of all non-hydrogen atoms, are inside the map.

9.5 Map-model fit summary



















The table lists the average atom inclusion at the recommended contour level (0.461) and Q-score for the entire model and for each chain.

Chain	Atom inclusion	Q-score
All	 0.8790	 0.6480
1	 0.9530	 0.6560
3	 0.9660	 0.6420
4	 0.9470	 0.6450
A	 0.9250	 0.6780
B	 0.8720	 0.6590
C	 0.8610	 0.6580
D	 0.7220	 0.6050
F	 0.8330	 0.6440
G	 0.7110	 0.6020
H	 0.7690	 0.6170
I	 0.8020	 0.6380
J	 0.6240	 0.5710
L	 0.8210	 0.6430
M	 0.7730	 0.6190
N	 0.9720	 0.6840
O	 0.8610	 0.6470
P	 0.8540	 0.6530
Q	 0.8750	 0.6510
R	 0.7620	 0.6220
S	 0.8580	 0.6480
T	 0.8610	 0.6500
U	 0.4150	 0.5480
V	 0.8220	 0.6520
W	 0.8630	 0.6490
X	 0.8480	 0.6520
Y	 0.8540	 0.6400
Z	 0.6280	 0.5930
a	 0.9270	 0.6700
b	 0.9050	 0.6590
c	 0.6890	 0.6160
d	 0.8560	 0.6510
e	 0.8740	 0.6470
f	 0.8240	 0.6480
g	 0.8940	 0.6530



Continued on next page...

Continued from previous page...

Chain	Atom inclusion	Q-score
h	 0.7500	 0.6110
i	 0.8140	 0.6330
j	 0.9260	 0.6740
k	 0.4970	 0.5470
l	 0.9260	 0.6670
m	 0.8430	 0.6390
n	 0.9200	 0.6640
o	 0.8790	 0.6660
p	 0.8370	 0.6540