



wwPDB EM Validation Summary Report ⓘ

Mar 5, 2026 – 04:07 PM UTC

PDB ID : 9IMK / pdb_00009imk
EMDB ID : EMD-60692
Title : SARS-CoV-2 Replication-Transcription Complex has a dimer architecture (dRTC) in post-capping state
Authors : Yan, L.M.; Rao, Z.H.; Lou, Z.Y.
Deposited on : 2024-07-03
Resolution : 4.01 Å(reported)

This is a wwPDB EM Validation Summary Report for a publicly released PDB entry.

We welcome your comments at validation@mail.wwpdb.org

A user guide is available at

<https://www.wwpdb.org/validation/2017/EMValidationReportHelp>

with specific help available everywhere you see the ⓘ symbol.

The types of validation reports are described at

<http://www.wwpdb.org/validation/2017/FAQs#types>.

The following versions of software and data (see [references ⓘ](#)) were used in the production of this report:

EMDB validation analysis : 0.0.1.dev132
Mogul : 2022.3.0, CSD as543be (2022)
MolProbity : 4-5-2 with Phenix2.0
Percentile statistics : 20250101.v01 (using entries in the PDB archive January 1st 2025)
EM percentile statistics : 202505.v01 (Using data in the EMDB archive up until May 2025)
MapQ : 1.9.13
Ideal geometry (proteins) : Engh & Huber (2001)
Ideal geometry (DNA, RNA) : Parkinson et al. (1996)
Validation Pipeline (wwPDB-VP) : 2.49

1 Overall quality at a glance i

The following experimental techniques were used to determine the structure:
ELECTRON MICROSCOPY

The reported resolution of this entry is 4.01 Å.

Percentile scores (ranging between 0-100) for global validation metrics of the entry are shown in the following graphic. The table shows the number of entries on which the scores are based.

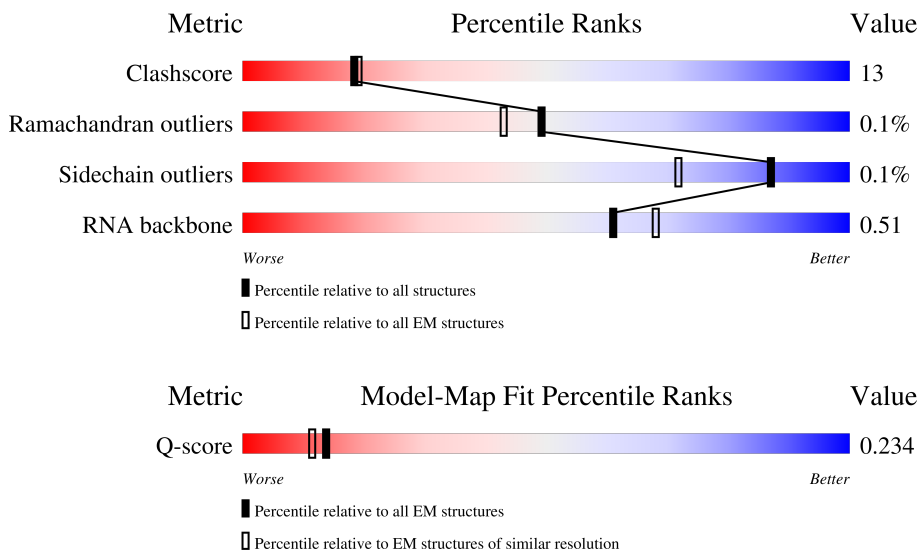



Metric	Whole archive (#Entries)	EM structures (#Entries)	Similar EM resolution (#Entries, resolution range(Å))
Clashscore	229148	23984	-
Ramachandran outliers	224038	23583	-
Sidechain outliers	223484	23102	-
RNA backbone	8273	3508	-
Q-score	-	25397	6765 (3.51 - 4.51)

The table below summarises the geometric issues observed across the polymeric chains and their fit to the map. The red, orange, yellow and green segments of the bar indicate the fraction of residues that contain outliers for ≥ 3 , 2, 1 and 0 types of geometric quality criteria respectively. A grey segment represents the fraction of residues that are not modelled. The numeric value for each fraction is indicated below the corresponding segment, with a dot representing fractions $\leq 5\%$. The upper red bar (where present) indicates the fraction of residues that have poor fit to the EM map (all-atom inclusion $< 40\%$). The numeric value is given above the bar.

Mol	Chain	Length	Quality of chain
1	A	932	
1	H	932	
2	B	198	

Continued on next page...

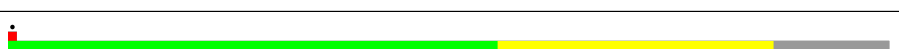
Continued from previous page...

Mol	Chain	Length	Quality of chain
2	D	198	 56% 37% 6%
2	I	198	 67% 27% 6%
2	K	198	 59% 35% 6%
3	C	83	 61% 25% 13%
3	J	83	 55% 31% 13%
4	E	601	 20% 74% 23%
4	F	601	 18% 76% 21%
4	L	601	 20% 71% 26%
4	M	601	 18% 72% 25%
5	G	113	 55% 45%
5	N	113	 57% 43%
6	O	40	 12% 72% 15%
6	P	40	 15% 70% 12%
7	Q	59	 17% 49% 12% 22%
7	R	59	 15% 47% 15% 22%

2 Entry composition [i](#)

There are 9 unique types of molecules in this entry. The entry contains 45119 atoms, of which 0 are hydrogens and 0 are deuteriums.

In the tables below, the AltConf column contains the number of residues with at least one atom in alternate conformation and the Trace column contains the number of residues modelled with at most 2 atoms.

- Molecule 1 is a protein called RNA-directed RNA polymerase nsp12.

Mol	Chain	Residues	Atoms					AltConf	Trace
			Total	C	N	O	S		
1	A	926	Total	C	N	O	S	3	0
			7473	4772	1256	1391	54		
1	H	926	Total	C	N	O	S	3	0
			7473	4772	1256	1391	54		

- Molecule 2 is a protein called Non-structural protein 8.

Mol	Chain	Residues	Atoms					AltConf	Trace
			Total	C	N	O	S		
2	B	187	Total	C	N	O	S	0	0
			1400	873	241	275	11		
2	D	186	Total	C	N	O	S	0	0
			1418	892	243	272	11		
2	I	187	Total	C	N	O	S	0	0
			1400	873	241	275	11		
2	K	186	Total	C	N	O	S	0	0
			1418	892	243	272	11		

- Molecule 3 is a protein called Non-structural protein 7.

Mol	Chain	Residues	Atoms					AltConf	Trace
			Total	C	N	O	S		
3	C	72	Total	C	N	O	S	0	0
			553	349	91	107	6		
3	J	72	Total	C	N	O	S	0	0
			553	349	91	107	6		

- Molecule 4 is a protein called Helicase nsp13.

Mol	Chain	Residues	Atoms					AltConf	Trace
			Total	C	N	O	S		
4	E	585	Total	C	N	O	S	1	0
			4500	2870	749	847	34		
4	F	585	Total	C	N	O	S	1	0
			4508	2875	750	848	35		

Continued on next page...

Continued from previous page...

Mol	Chain	Residues	Atoms					AltConf	Trace
4	L	585	Total	C	N	O	S	1	0
			4500	2870	749	847	34		
4	M	585	Total	C	N	O	S	1	0
			4508	2875	750	848	35		

- Molecule 5 is a protein called Viral protein genome-linked nsp9.

Mol	Chain	Residues	Atoms					AltConf	Trace
5	G	113	Total	C	N	O	S	0	0
			868	549	150	164	5		
5	N	113	Total	C	N	O	S	0	0
			868	549	150	164	5		

- Molecule 6 is a RNA chain called RNA (40-MER).

Mol	Chain	Residues	Atoms					AltConf	Trace
6	P	40	Total	C	N	O	P	0	0
			853	380	151	280	42		
6	O	40	Total	C	N	O	P	0	0
			853	380	151	280	42		

- Molecule 7 is a RNA chain called RNA (59-MER).

Mol	Chain	Residues	Atoms					AltConf	Trace
7	R	46	Total	C	N	O	P	0	0
			977	437	169	325	46		
7	Q	46	Total	C	N	O	P	0	0
			977	437	169	325	46		

- Molecule 8 is ZINC ION (CCD ID: ZN) (formula: Zn) (labeled as "Ligand of Interest" by depositor).

Mol	Chain	Residues	Atoms		AltConf
8	A	2	Total	Zn	0
			2	2	
8	E	3	Total	Zn	0
			3	3	
8	F	3	Total	Zn	0
			3	3	
8	H	2	Total	Zn	0
			2	2	

Continued on next page...

Continued from previous page...

Mol	Chain	Residues	Atoms		AltConf
8	L	3	Total 3	Zn 3	0
8	M	3	Total 3	Zn 3	0

- Molecule 9 is water.

Mol	Chain	Residues	Atoms		AltConf
9	A	1	Total 1	O 1	0
9	G	1	Total 1	O 1	0
9	H	1	Total 1	O 1	0

3 Residue-property plots [i](#)

These plots are drawn for all protein, RNA, DNA and oligosaccharide chains in the entry. The first graphic for a chain summarises the proportions of the various outlier classes displayed in the second graphic. The second graphic shows the sequence view annotated by issues in geometry and atom inclusion in map density. Residues are color-coded according to the number of geometric quality criteria for which they contain at least one outlier: green = 0, yellow = 1, orange = 2 and red = 3 or more. A red diamond above a residue indicates a poor fit to the EM map for this residue (all-atom inclusion < 40%). Stretches of 2 or more consecutive residues without any outlier are shown as a green connector. Residues present in the sample, but not in the model, are shown in grey.

- Molecule 1: RNA-directed RNA polymerase nsp12

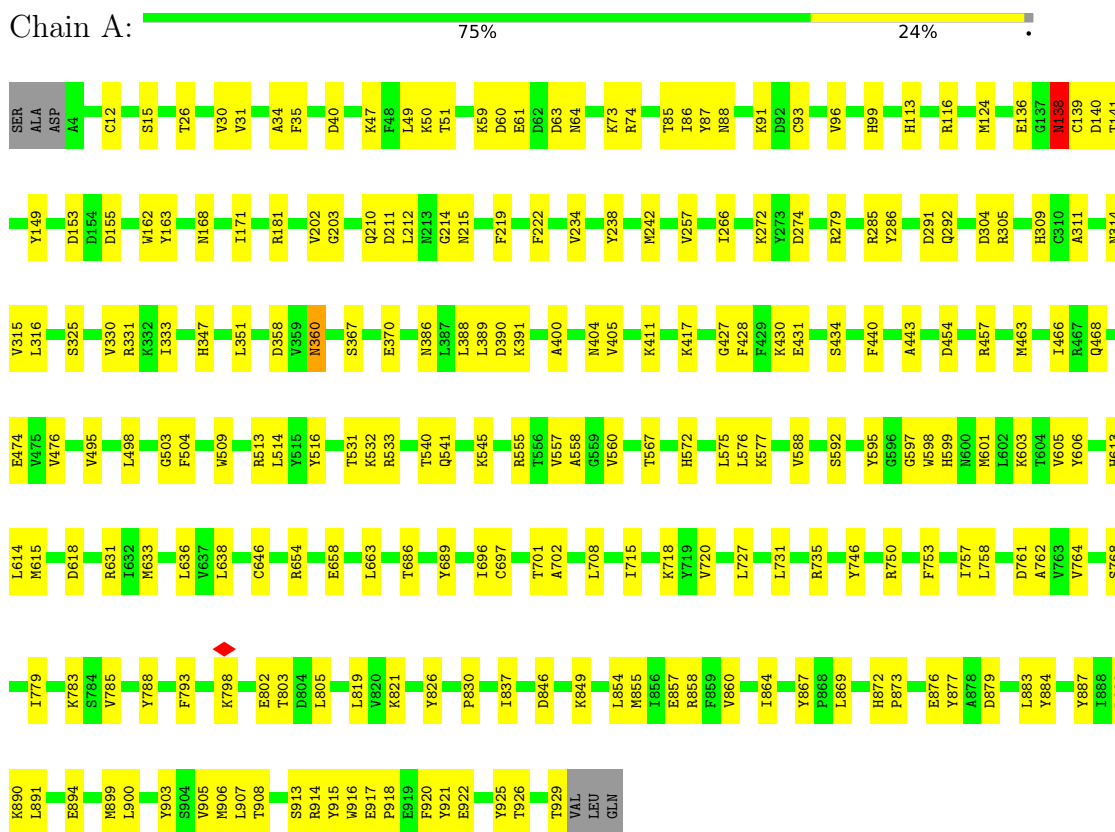

- Molecule 1: RNA-directed RNA polymerase nsp12

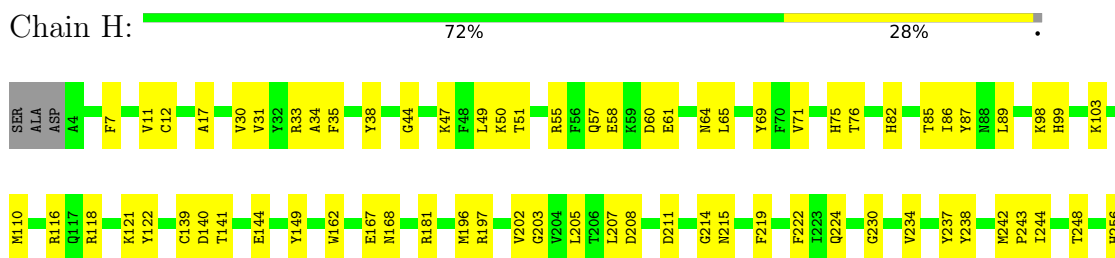

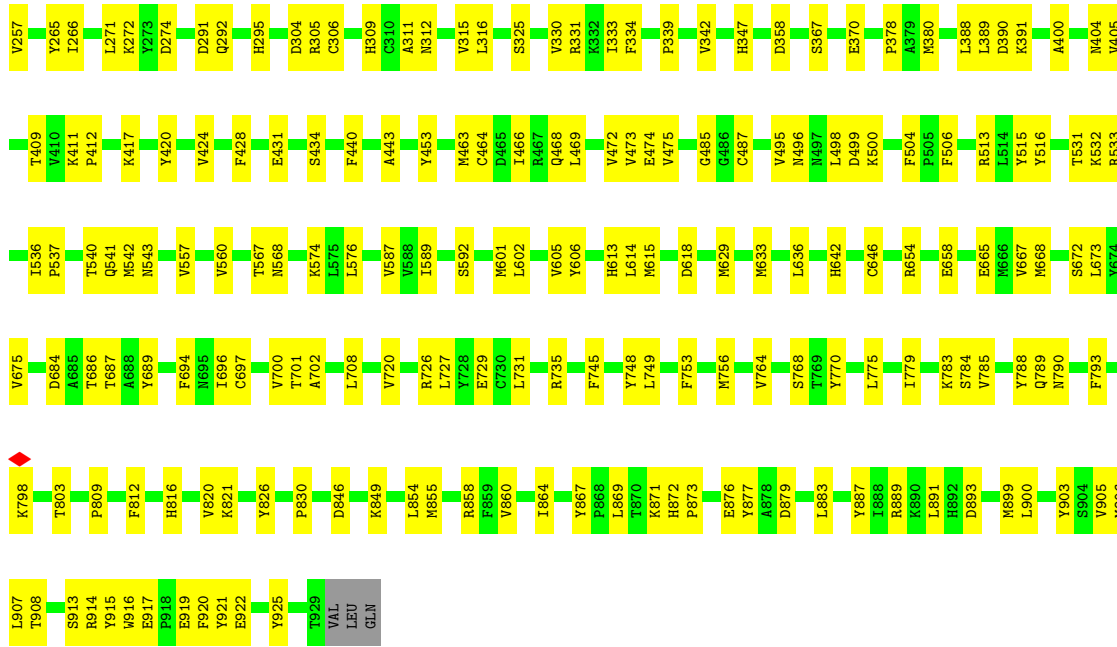

• Molecule 2: Non-structural protein 8

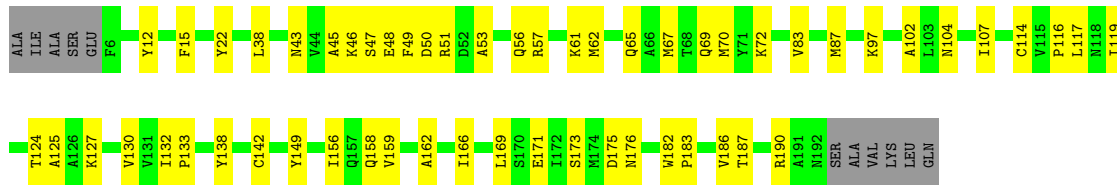

• Molecule 2: Non-structural protein 8

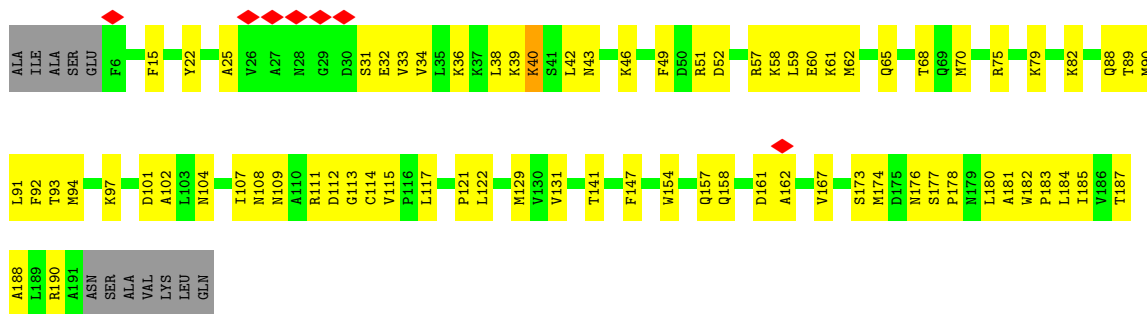

• Molecule 2: Non-structural protein 8

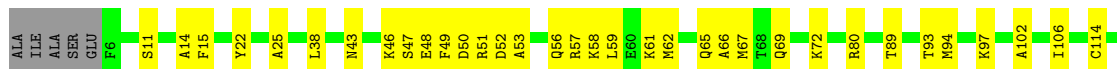



• Molecule 2: Non-structural protein 8

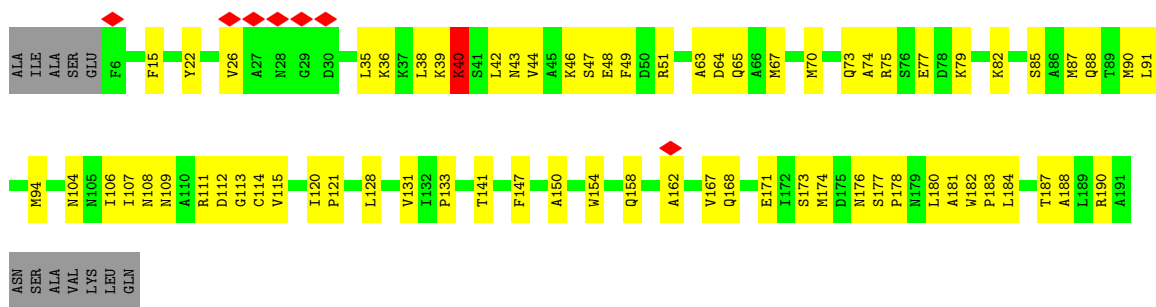

• Molecule 3: Non-structural protein 7

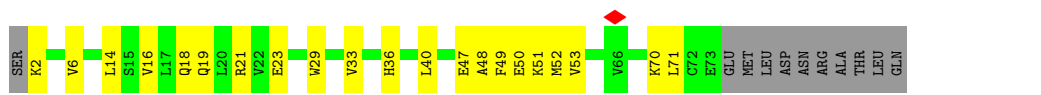

• Molecule 3: Non-structural protein 7



• Molecule 4: Helicase nsp13

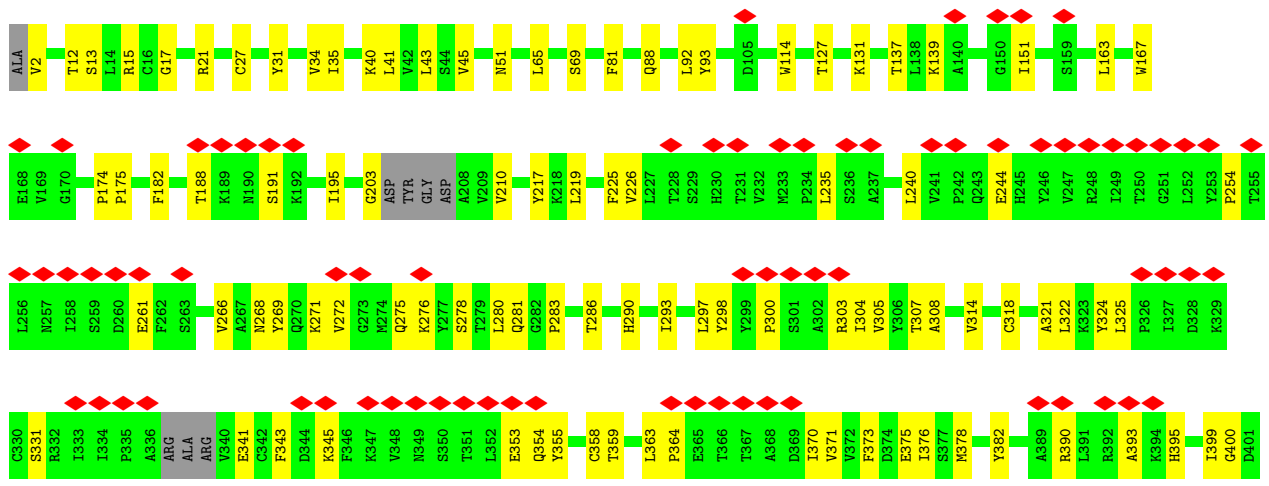
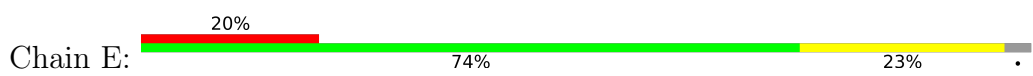

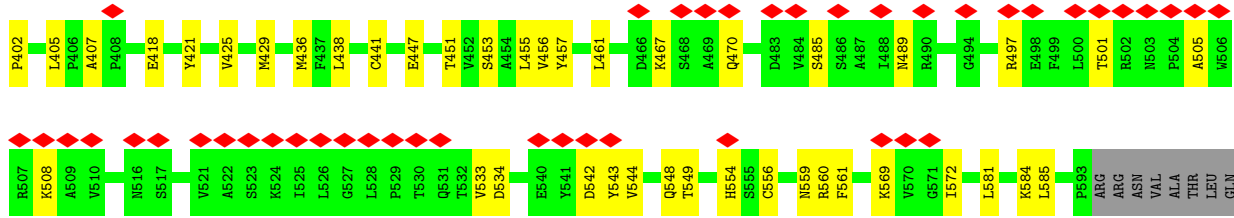

• Molecule 4: Helicase nsp13

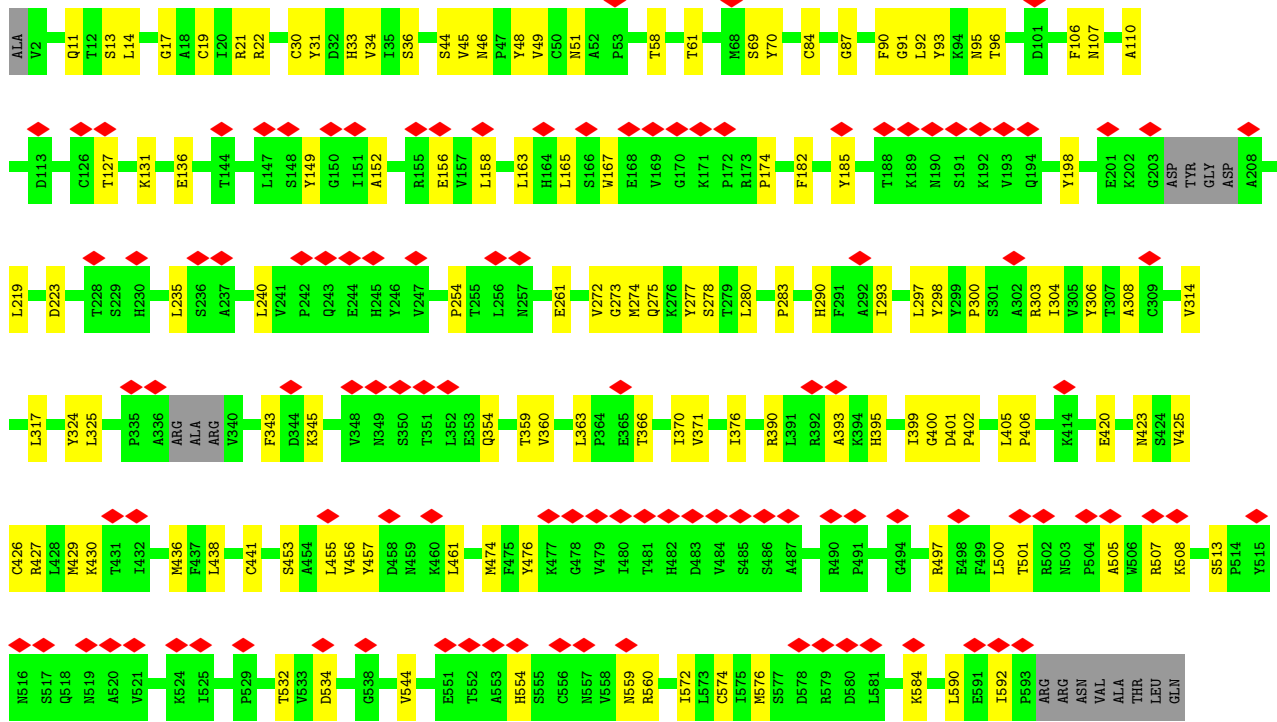
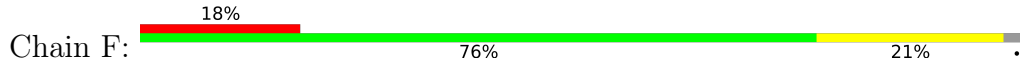

• Molecule 4: Helicase nsp13

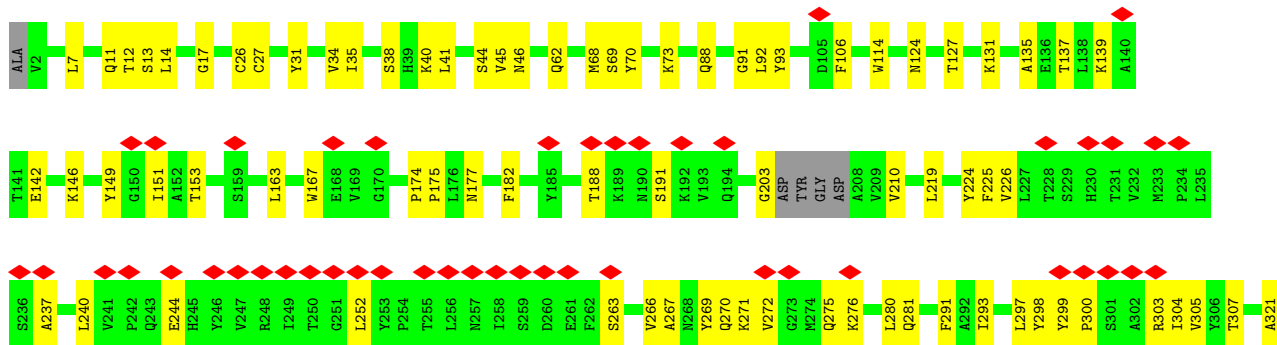

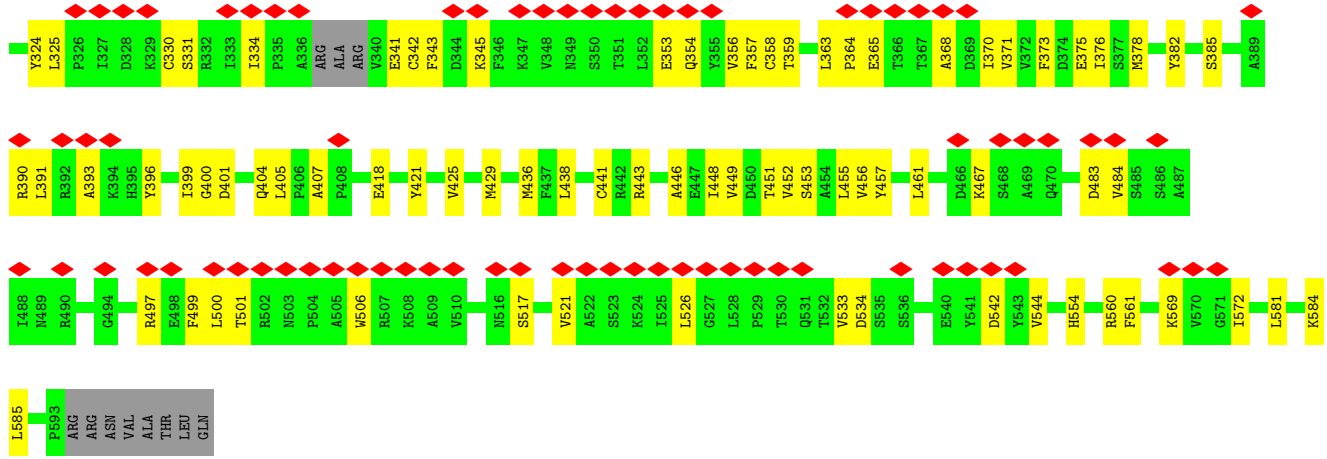

• Molecule 4: Helicase nsp13

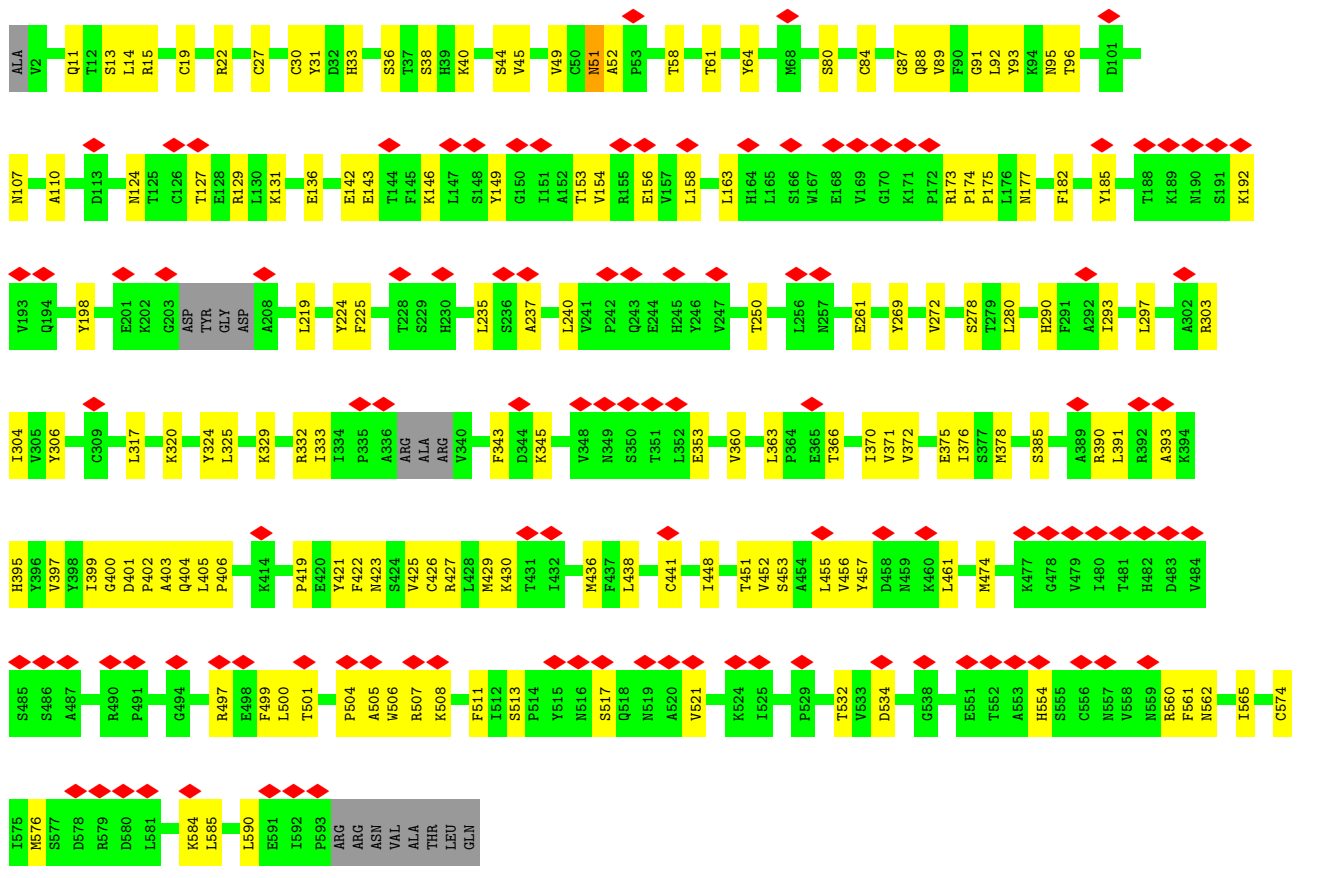
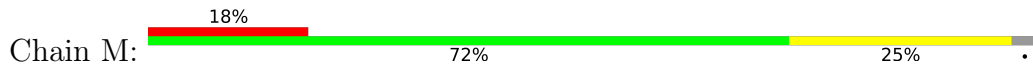

• Molecule 5: Viral protein genome-linked nsp9

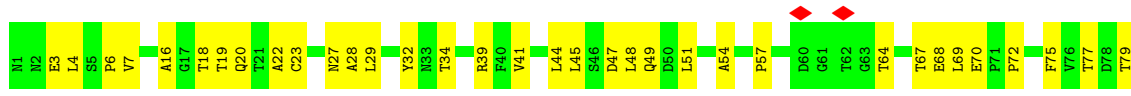

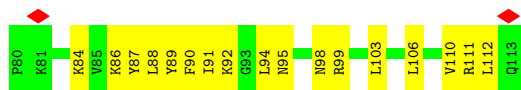

• Molecule 5: Viral protein genome-linked nsp9

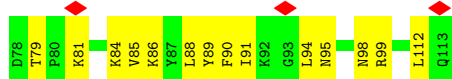

• Molecule 6: RNA (40-MER)

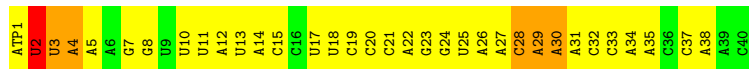

• Molecule 6: RNA (40-MER)

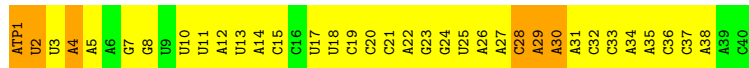
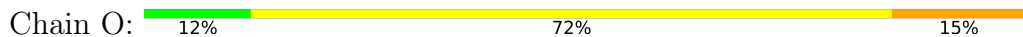

• Molecule 7: RNA (59-MER)

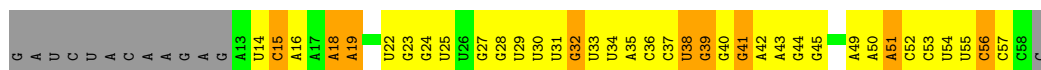
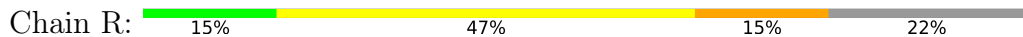

• Molecule 7: RNA (59-MER)

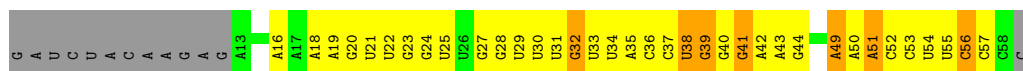
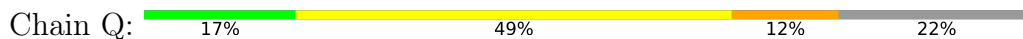

4 Experimental information

Property	Value	Source
EM reconstruction method	SINGLE PARTICLE	Depositor
Imposed symmetry	POINT, Not provided	
Number of particles used	753559	Depositor
Resolution determination method	FSC 0.143 CUT-OFF	Depositor
CTF correction method	PHASE FLIPPING AND AMPLITUDE CORRECTION	Depositor
Microscope	TFS KRIOS	Depositor
Voltage (kV)	300	Depositor
Electron dose ($e^-/\text{\AA}^2$)	60	Depositor
Minimum defocus (nm)	1000	Depositor
Maximum defocus (nm)	2000	Depositor
Magnification	Not provided	
Image detector	GATAN K2 QUANTUM (4k x 4k)	Depositor
Maximum map value	1.241	Depositor
Minimum map value	-0.654	Depositor
Average map value	0.000	Depositor
Map value standard deviation	0.033	Depositor
Recommended contour level	0.12	Depositor
Map size (\AA)	393.6, 393.6, 393.6	wwPDB
Map dimensions	480, 480, 480	wwPDB
Map angles ($^\circ$)	90.0, 90.0, 90.0	wwPDB
Pixel spacing (\AA)	0.82, 0.82, 0.82	Depositor

5 Model quality i

5.1 Standard geometry i

Bond lengths and bond angles in the following residue types are not validated in this section: ATP, ZN

The Z score for a bond length (or angle) is the number of standard deviations the observed value is removed from the expected value. A bond length (or angle) with $|Z| > 5$ is considered an outlier worth inspection. RMSZ is the root-mean-square of all Z scores of the bond lengths (or angles).

Mol	Chain	Bond lengths		Bond angles	
		RMSZ	# Z >5	RMSZ	# Z >5
1	A	0.24	0/7662	0.49	7/10397 (0.1%)
1	H	0.23	0/7662	0.59	2/10397 (0.0%)
2	B	0.23	0/1418	0.50	1/1927 (0.1%)
2	D	0.17	0/1437	0.50	1/1948 (0.1%)
2	I	0.22	0/1418	0.53	0/1927
2	K	0.18	0/1437	0.53	1/1948 (0.1%)
3	C	0.16	0/556	0.47	0/749
3	J	0.17	0/556	0.49	0/749
4	E	0.13	0/4602	0.34	0/6273
4	F	0.13	0/4610	0.35	0/6283
4	L	0.13	0/4602	0.37	0/6273
4	M	0.16	0/4610	0.38	2/6283 (0.0%)
5	G	0.21	0/884	0.53	0/1200
5	N	0.20	0/884	0.52	0/1200
6	O	0.20	0/918	0.39	1/1425 (0.1%)
6	P	0.30	1/918 (0.1%)	0.41	1/1425 (0.1%)
7	Q	0.40	3/1091 (0.3%)	0.32	0/1697
7	R	0.40	3/1091 (0.3%)	0.37	0/1697
All	All	0.21	7/46356 (0.0%)	0.46	16/63798 (0.0%)

Chiral center outliers are detected by calculating the chiral volume of a chiral center and verifying if the center is modelled as a planar moiety or with the opposite hand. A planarity outlier is detected by checking planarity of atoms in a peptide group, atoms in a mainchain group or atoms of a sidechain that are expected to be planar.

Mol	Chain	#Chirality outliers	#Planarity outliers
2	B	0	1
2	I	0	1
All	All	0	2

The worst 5 of 7 bond length outliers are listed below:

Mol	Chain	Res	Type	Atoms	Z	Observed(Å)	Ideal(Å)
6	P	2	U	P-OP1	-7.81	1.33	1.49
7	Q	41	G	C1'-N9	-6.54	1.38	1.48
7	R	41	G	C1'-N9	-6.52	1.38	1.48
7	R	39	G	C1'-N9	-6.20	1.38	1.48
7	Q	39	G	C1'-N9	-6.15	1.38	1.48

The worst 5 of 16 bond angle outliers are listed below:

Mol	Chain	Res	Type	Atoms	Z	Observed(°)	Ideal(°)
1	H	504	PHE	CA-C-N	-25.08	88.49	119.84
1	H	504	PHE	C-N-CA	-25.08	88.49	119.84
1	A	504	PHE	CA-C-N	-8.80	110.36	120.12
1	A	504	PHE	C-N-CA	-8.80	110.36	120.12
6	P	2	U	O5'-P-OP1	-7.38	85.87	108.00

There are no chirality outliers.

All (2) planarity outliers are listed below:

Mol	Chain	Res	Type	Group
2	B	182	TRP	Peptide
2	I	182	TRP	Peptide

5.2 Too-close contacts [i](#)

In the following table, the Non-H and H(model) columns list the number of non-hydrogen atoms and hydrogen atoms in the chain respectively. The H(added) column lists the number of hydrogen atoms added and optimized by MolProbity. The Clashes column lists the number of clashes within the asymmetric unit, whereas Symm-Clashes lists symmetry-related clashes.

Mol	Chain	Non-H	H(model)	H(added)	Clashes	Symm-Clashes
1	A	7473	0	7213	169	0
1	H	7473	0	7213	184	0
2	B	1400	0	1372	44	0
2	D	1418	0	1427	64	0
2	I	1400	0	1372	44	0
2	K	1418	0	1427	55	0
3	C	553	0	585	23	0
3	J	553	0	585	28	0
4	E	4500	0	4414	89	0
4	F	4508	0	4423	78	0
4	L	4500	0	4414	109	0
4	M	4508	0	4423	95	0

Continued on next page...

Continued from previous page...

Mol	Chain	Non-H	H(model)	H(added)	Clashes	Symm-Clashes
5	G	868	0	880	41	0
5	N	868	0	880	35	0
6	O	853	0	432	51	0
6	P	853	0	432	49	0
7	Q	977	0	492	48	0
7	R	977	0	492	53	0
8	A	2	0	0	0	0
8	E	3	0	0	0	0
8	F	3	0	0	0	0
8	H	2	0	0	0	0
8	L	3	0	0	0	0
8	M	3	0	0	0	0
9	A	1	0	0	0	0
9	G	1	0	0	0	0
9	H	1	0	0	0	0
All	All	45119	0	42476	1147	0

The all-atom clashscore is defined as the number of clashes found per 1000 atoms (including hydrogen atoms). The all-atom clashscore for this structure is 13.

The worst 5 of 1147 close contacts within the same asymmetric unit are listed below, sorted by their clash magnitude.

Atom-1	Atom-2	Interatomic distance (Å)	Clash overlap (Å)
1:H:487:CYS:SG	1:H:642:HIS:HE1	1.96	0.89
6:O:20:C:C2	7:Q:41:G:N1	2.41	0.89
2:I:69:GLN:HA	2:I:72:LYS:HE3	1.53	0.89
2:B:69:GLN:HA	2:B:72:LYS:HE3	1.58	0.86
6:P:20:C:C2	7:R:41:G:N1	2.45	0.85

There are no symmetry-related clashes.

5.3 Torsion angles [i](#)

5.3.1 Protein backbone [i](#)

In the following table, the Percentiles column shows the percent Ramachandran outliers of the chain as a percentile score with respect to all PDB entries followed by that with respect to all EM entries.

The Analysed column shows the number of residues for which the backbone conformation was analysed, and the total number of residues.

Mol	Chain	Analysed	Favoured	Allowed	Outliers	Percentiles	
1	A	925/932 (99%)	884 (96%)	39 (4%)	2 (0%)	43	75
1	H	925/932 (99%)	874 (94%)	49 (5%)	2 (0%)	43	75
2	B	185/198 (93%)	176 (95%)	9 (5%)	0	100	100
2	D	184/198 (93%)	176 (96%)	8 (4%)	0	100	100
2	I	185/198 (93%)	177 (96%)	8 (4%)	0	100	100
2	K	184/198 (93%)	175 (95%)	9 (5%)	0	100	100
3	C	70/83 (84%)	69 (99%)	1 (1%)	0	100	100
3	J	70/83 (84%)	69 (99%)	1 (1%)	0	100	100
4	E	579/601 (96%)	566 (98%)	13 (2%)	0	100	100
4	F	580/601 (96%)	560 (97%)	20 (3%)	0	100	100
4	L	579/601 (96%)	562 (97%)	17 (3%)	0	100	100
4	M	580/601 (96%)	560 (97%)	20 (3%)	0	100	100
5	G	111/113 (98%)	98 (88%)	12 (11%)	1 (1%)	14	48
5	N	111/113 (98%)	103 (93%)	7 (6%)	1 (1%)	14	48
All	All	5268/5452 (97%)	5049 (96%)	213 (4%)	6 (0%)	49	81

5 of 6 Ramachandran outliers are listed below:

Mol	Chain	Res	Type
1	A	61	GLU
1	H	61	GLU
5	G	7	VAL
1	H	140	ASP
5	N	7	VAL

5.3.2 Protein sidechains [i](#)

In the following table, the Percentiles column shows the percent sidechain outliers of the chain as a percentile score with respect to all PDB entries followed by that with respect to all EM entries.

The Analysed column shows the number of residues for which the sidechain conformation was analysed, and the total number of residues.

Mol	Chain	Analysed	Rotameric	Outliers	Percentiles	
1	A	819/823 (100%)	817 (100%)	2 (0%)	87	87
1	H	819/823 (100%)	819 (100%)	0	100	100

Continued on next page...

Continued from previous page...

Mol	Chain	Analysed	Rotameric	Outliers	Percentiles	
2	B	146/167 (87%)	146 (100%)	0	100	100
2	D	150/167 (90%)	150 (100%)	0	100	100
2	I	146/167 (87%)	145 (99%)	1 (1%)	76	79
2	K	150/167 (90%)	149 (99%)	1 (1%)	76	79
3	C	67/77 (87%)	67 (100%)	0	100	100
3	J	67/77 (87%)	67 (100%)	0	100	100
4	E	497/523 (95%)	497 (100%)	0	100	100
4	F	498/523 (95%)	498 (100%)	0	100	100
4	L	497/523 (95%)	497 (100%)	0	100	100
4	M	498/523 (95%)	497 (100%)	1 (0%)	87	87
5	G	94/94 (100%)	94 (100%)	0	100	100
5	N	94/94 (100%)	94 (100%)	0	100	100
All	All	4542/4748 (96%)	4537 (100%)	5 (0%)	87	89

All (5) residues with a non-rotameric sidechain are listed below:

Mol	Chain	Res	Type
1	A	138	ASN
1	A	360	ASN
2	I	47	SER
2	K	40	LYS
4	M	51	ASN

Sometimes sidechains can be flipped to improve hydrogen bonding and reduce clashes. 5 of 50 such sidechains are listed below:

Mol	Chain	Res	Type
1	H	81	GLN
1	H	886	GLN
5	N	98	ASN
1	H	113	HIS
1	H	611	ASN

5.3.3 RNA [i](#)

Continued on next page...

Continued from previous page...

Mol	Chain	Analysed	Backbone Outliers	Pucker Outliers
6	O	40/40 (100%)	4 (10%)	4 (10%)
6	P	40/40 (100%)	4 (10%)	4 (10%)
7	Q	45/59 (76%)	8 (17%)	0
7	R	45/59 (76%)	9 (20%)	1 (2%)
All	All	170/198 (85%)	25 (14%)	9 (5%)

5 of 25 RNA backbone outliers are listed below:

Mol	Chain	Res	Type
6	P	3	U
6	P	4	A
6	P	28	C
6	P	30	A
7	R	15	C

5 of 9 RNA pucker outliers are listed below:

Mol	Chain	Res	Type
6	O	3	U
6	O	29	A
6	P	29	A
7	R	18	A
6	O	1	ATP

5.4 Non-standard residues in protein, DNA, RNA chains [i](#)

There are no non-standard protein/DNA/RNA residues in this entry.

5.5 Carbohydrates [i](#)

There are no oligosaccharides in this entry.

5.6 Ligand geometry [i](#)

Of 16 ligands modelled in this entry, 16 are monoatomic - leaving 0 for Mogul analysis.

There are no bond length outliers.

There are no bond angle outliers.

There are no chirality outliers.

There are no torsion outliers.

There are no ring outliers.

No monomer is involved in short contacts.

5.7 Other polymers

There are no such residues in this entry.

5.8 Polymer linkage issues

There are no chain breaks in this entry.

6 Map visualisation [i](#)

This section contains visualisations of the EMDB entry EMD-60692. These allow visual inspection of the internal detail of the map and identification of artifacts.

Images derived from a raw map, generated by summing the deposited half-maps, are presented below the corresponding image components of the primary map to allow further visual inspection and comparison with those of the primary map.

6.1 Orthogonal projections [i](#)

6.1.1 Primary map

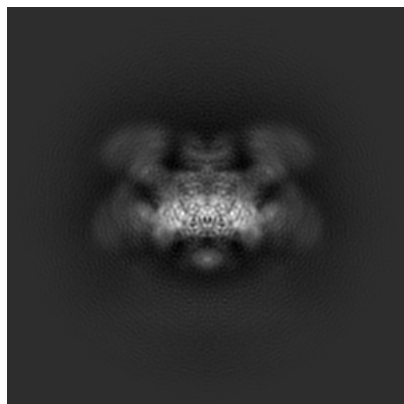

X

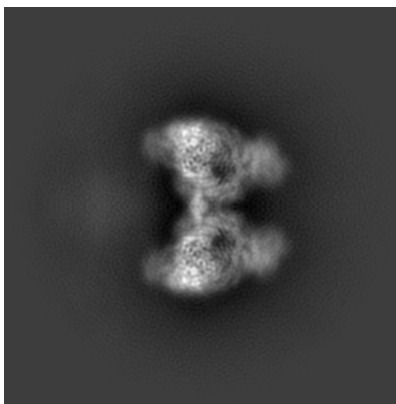

Y

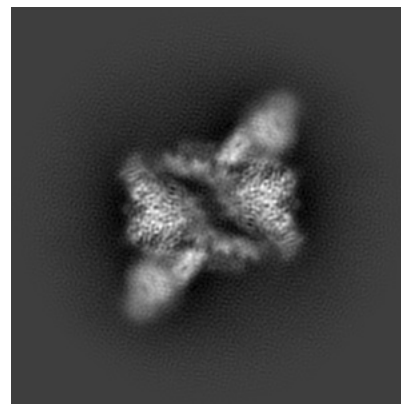

Z

6.1.2 Raw map

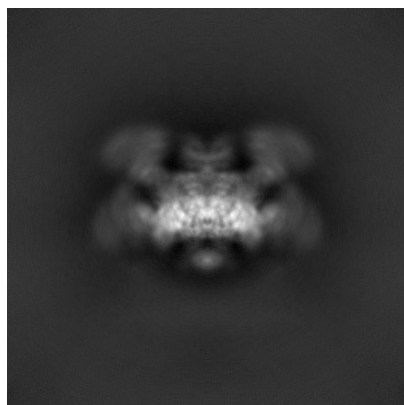

X

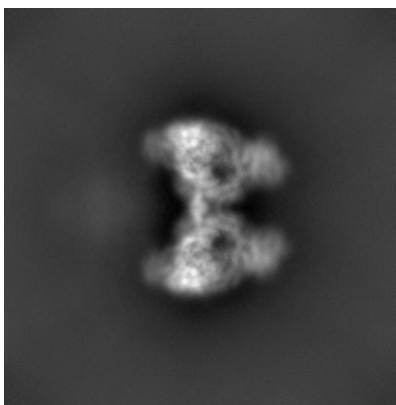

Y

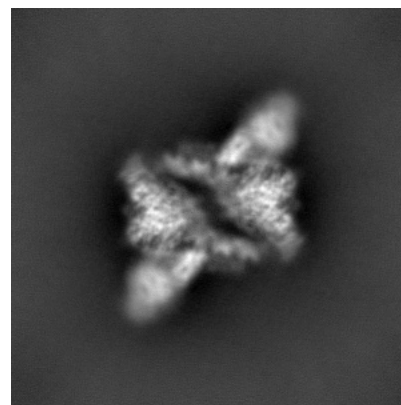

Z

The images above show the map projected in three orthogonal directions.

6.2 Central slices [i](#)

6.2.1 Primary map

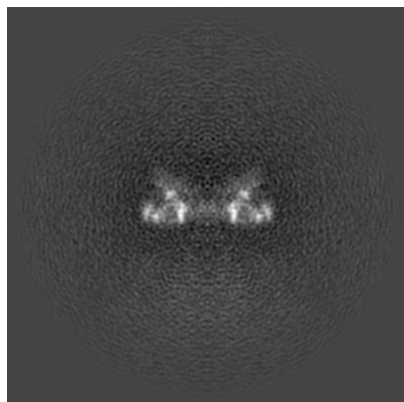

X Index: 240

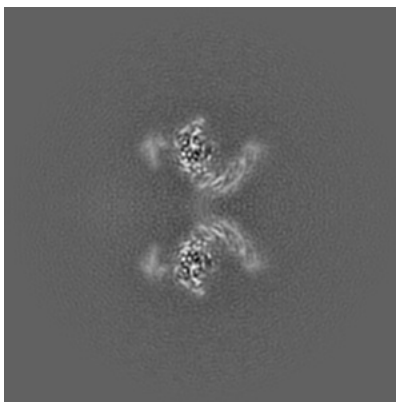

Y Index: 240

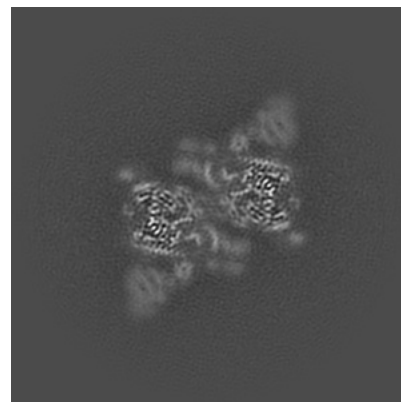

Z Index: 240

6.2.2 Raw map

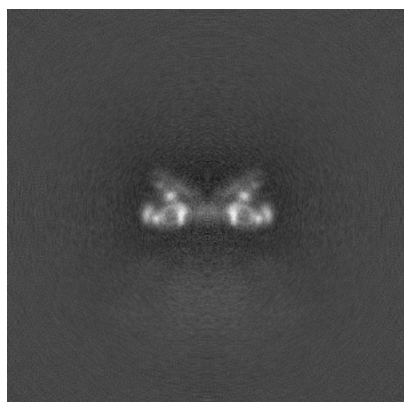

X Index: 240

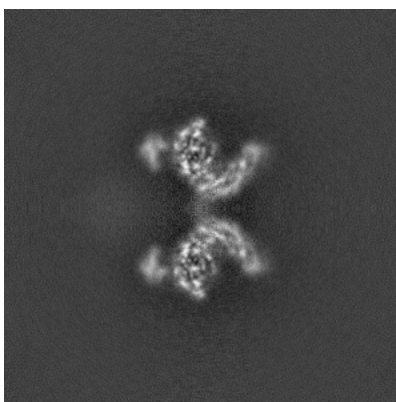

Y Index: 240

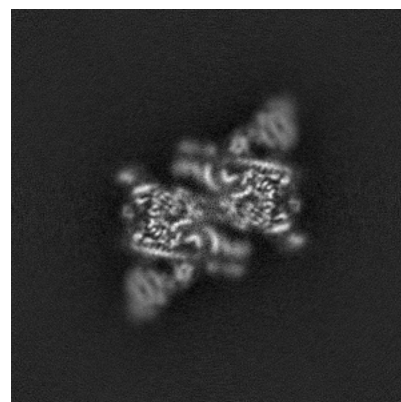

Z Index: 240

The images above show central slices of the map in three orthogonal directions.

6.3 Largest variance slices [i](#)

6.3.1 Primary map

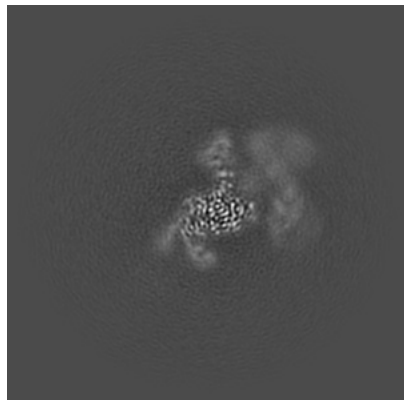

X Index: 305

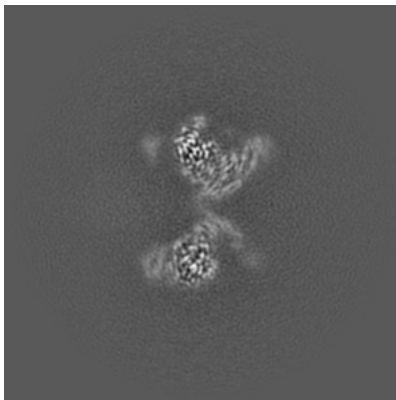

Y Index: 247

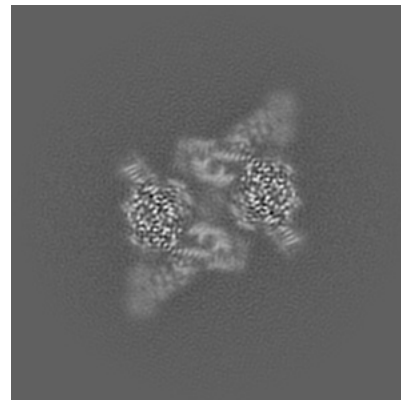

Z Index: 232

6.3.2 Raw map

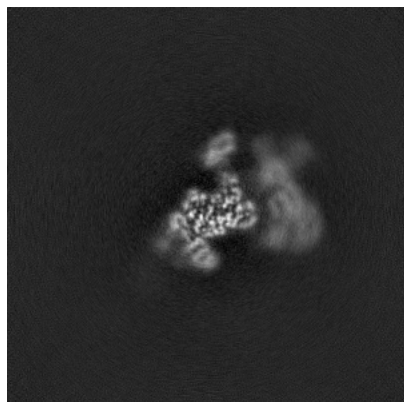

X Index: 314

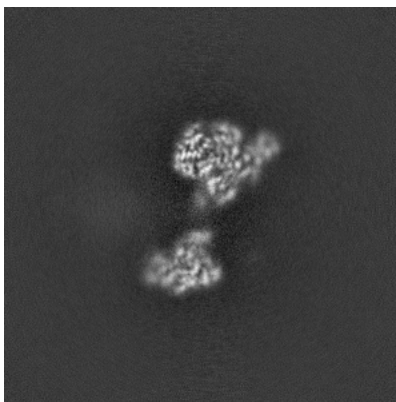

Y Index: 261

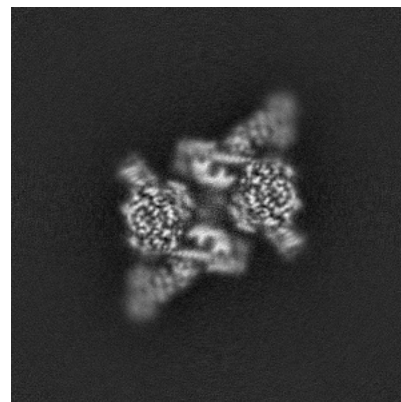

Z Index: 232

The images above show the largest variance slices of the map in three orthogonal directions.

6.4 Orthogonal standard-deviation projections (False-color) [i](#)

6.4.1 Primary map

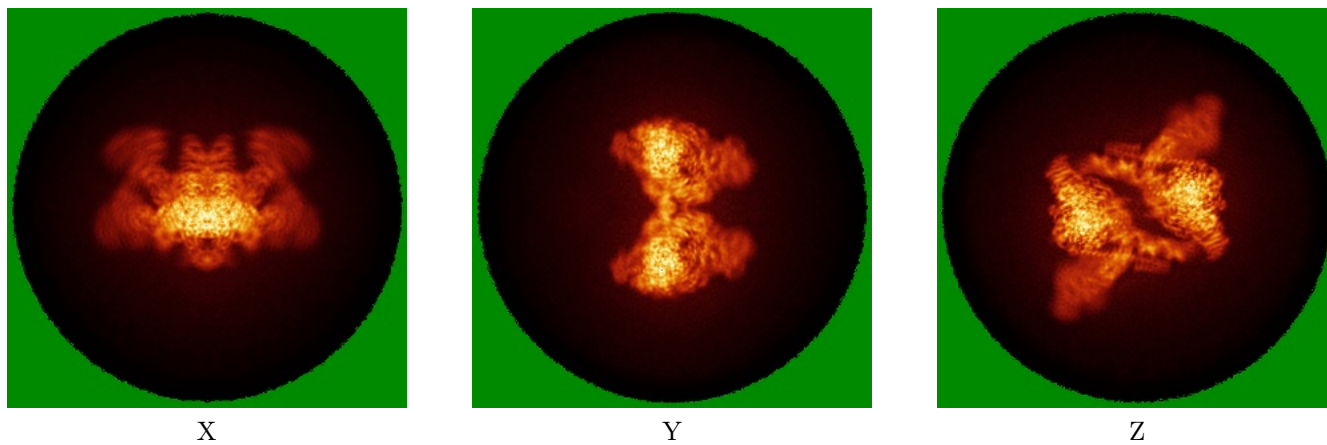

6.4.2 Raw map

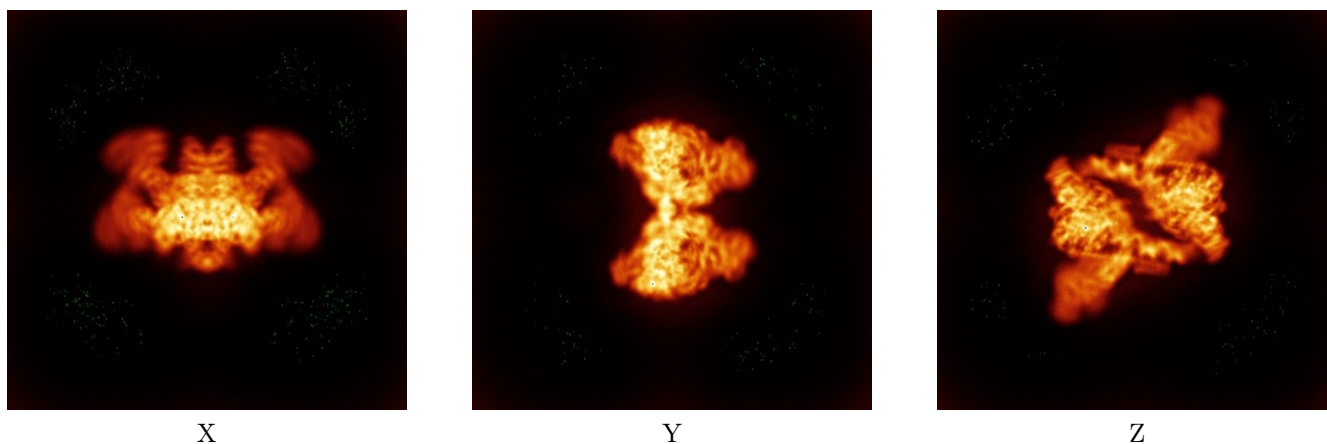

The images above show the map standard deviation projections with false color in three orthogonal directions. Minimum values are shown in green, max in blue, and dark to light orange shades represent small to large values respectively.

6.5 Orthogonal surface views [i](#)

This section was not generated.

6.6 Mask visualisation [i](#)

This section was not generated. No masks/segmentation were deposited.

7 Map analysis [i](#)

This section contains the results of statistical analysis of the map.

7.1 Map-value distribution [i](#)

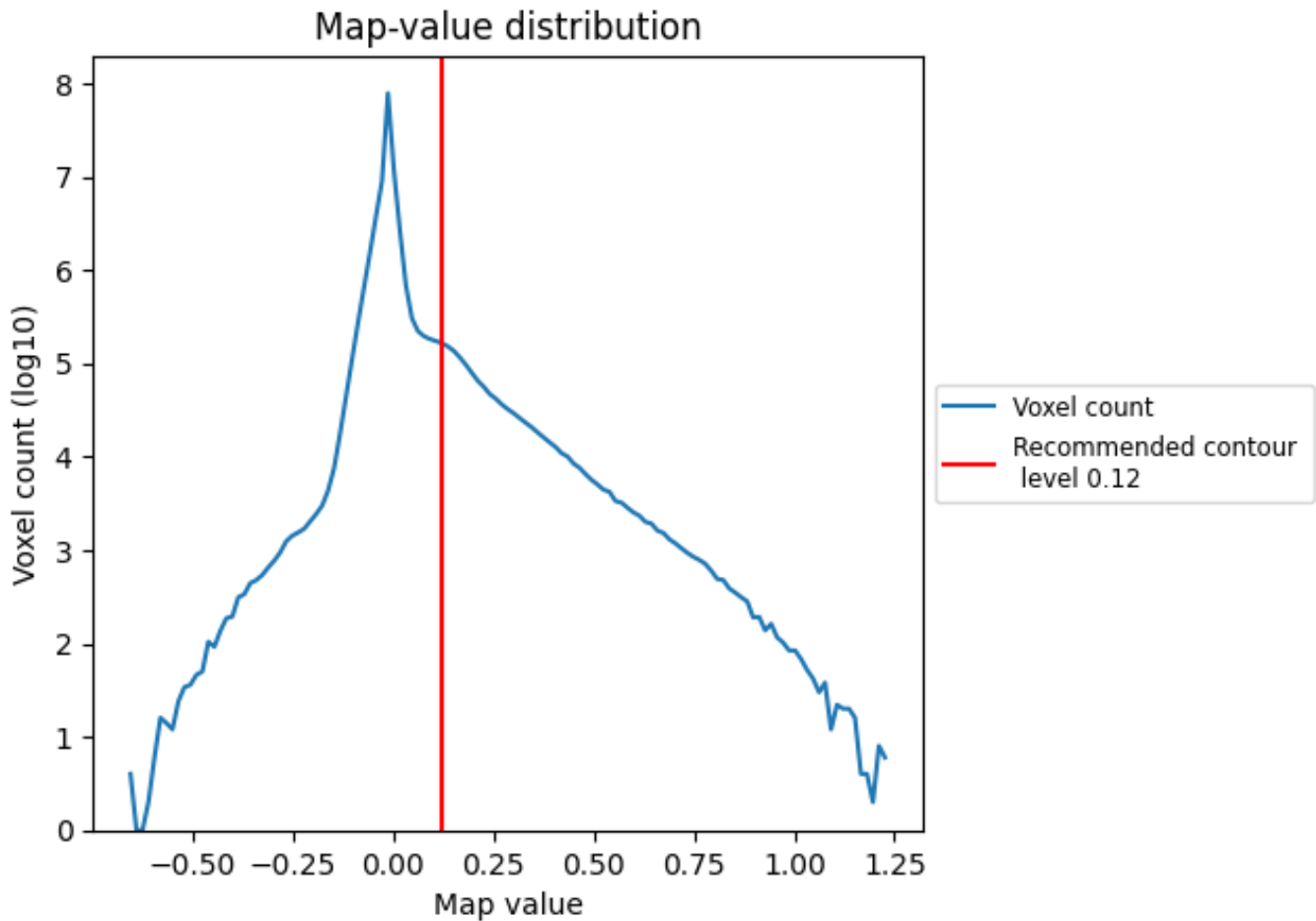

The map-value distribution is plotted in 128 intervals along the x-axis. The y-axis is logarithmic. A spike in this graph at zero usually indicates that the volume has been masked.

7.2 Volume estimate [\(i\)](#)

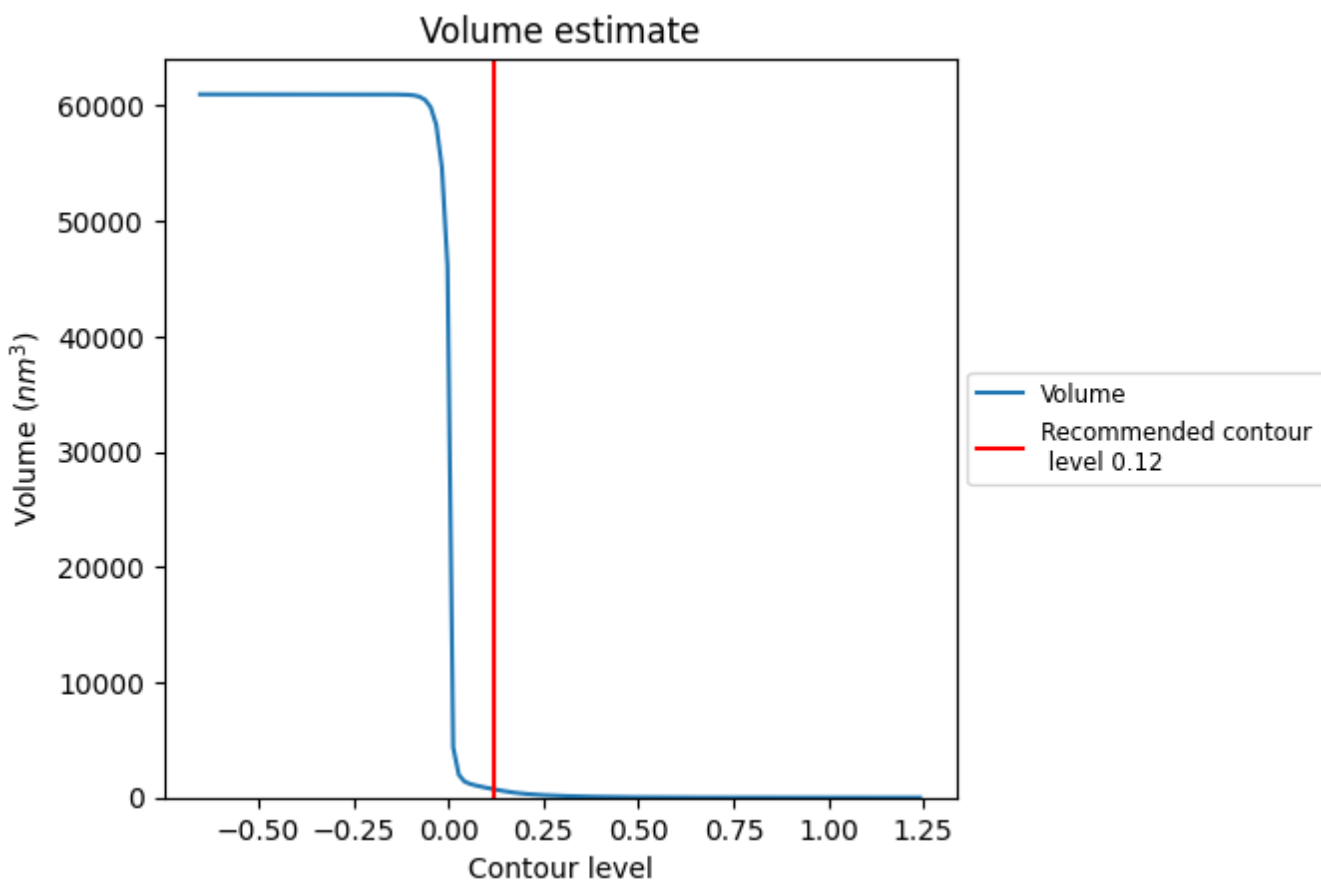

The volume at the recommended contour level is 717 nm³; this corresponds to an approximate mass of 647 kDa.

The volume estimate graph shows how the enclosed volume varies with the contour level. The recommended contour level is shown as a vertical line and the intersection between the line and the curve gives the volume of the enclosed surface at the given level.

7.3 Rotationally averaged power spectrum [i](#)

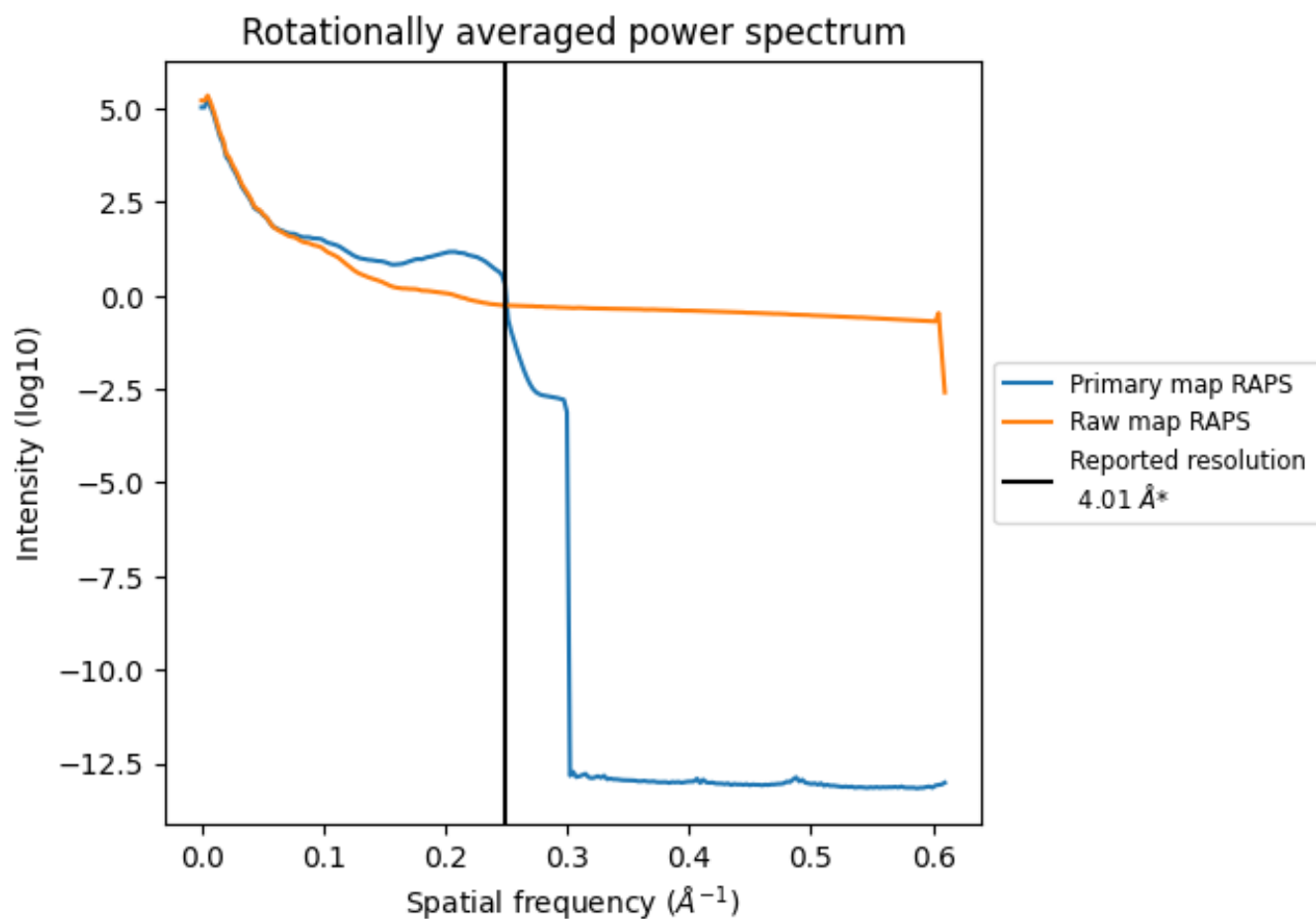

*Reported resolution corresponds to spatial frequency of 0.249 Å⁻¹

8 Fourier-Shell correlation [i](#)

Fourier-Shell Correlation (FSC) is the most commonly used method to estimate the resolution of single-particle and subtomogram-averaged maps. The shape of the curve depends on the imposed symmetry, mask and whether or not the two 3D reconstructions used were processed from a common reference. The reported resolution is shown as a black line. A curve is displayed for the half-bit criterion in addition to lines showing the 0.143 gold standard cut-off and 0.5 cut-off.

8.1 FSC [i](#)

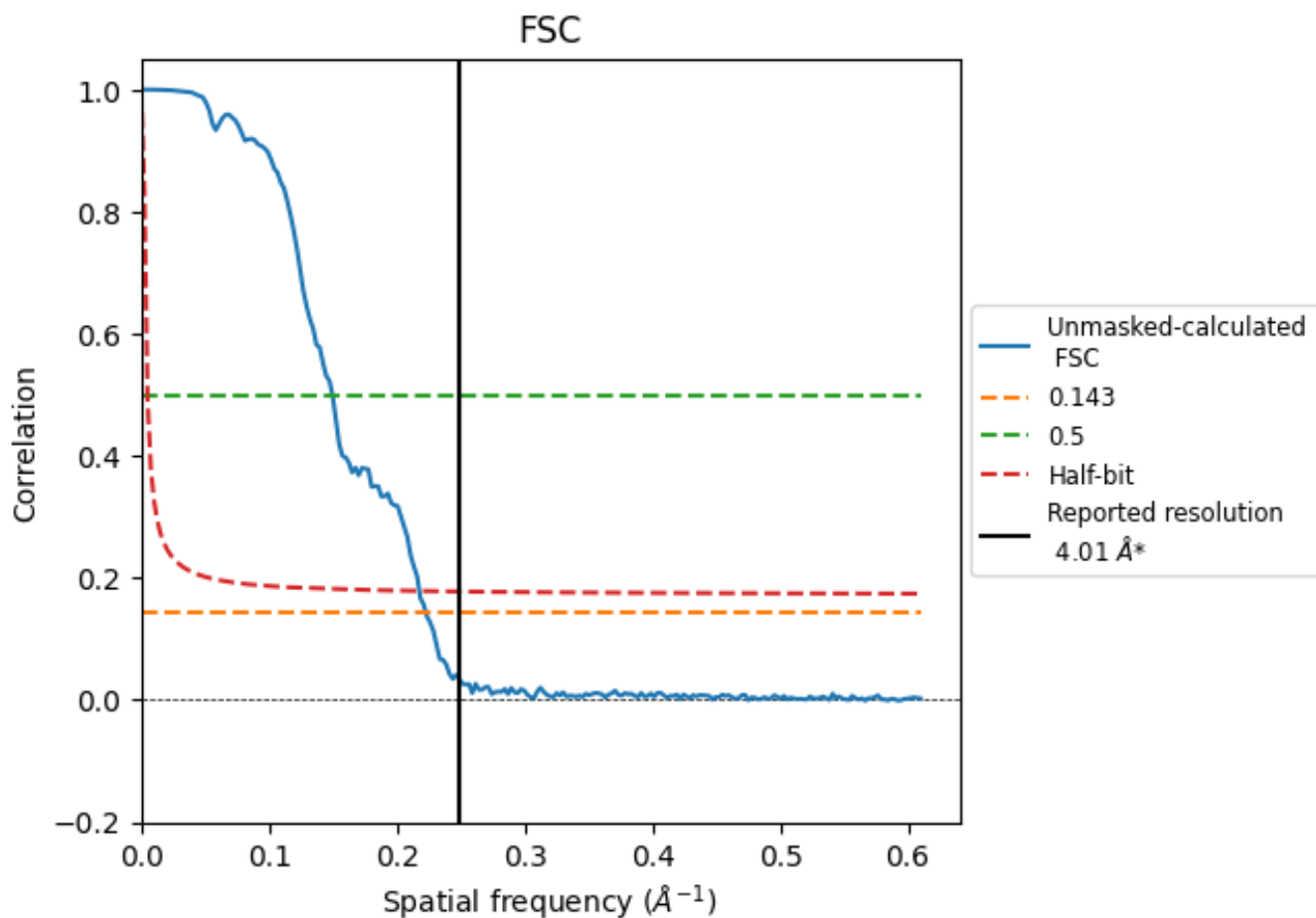

*Reported resolution corresponds to spatial frequency of 0.249 Å⁻¹

8.2 Resolution estimates [i](#)

Resolution estimate (Å)	Estimation criterion (FSC cut-off)		
	0.143	0.5	Half-bit
Reported by author	4.01	-	-
Author-provided FSC curve	-	-	-
Unmasked-calculated*	4.49	6.68	4.59

*Resolution estimate based on FSC curve calculated by comparison of deposited half-maps. The value from deposited half-maps intersecting FSC 0.143 CUT-OFF 4.49 differs from the reported value 4.01 by more than 10 %

9 Map-model fit [i](#)

This section contains information regarding the fit between EMDB map EMD-60692 and PDB model 9IMK. Per-residue inclusion information can be found in section 3 on page 7.

9.1 Map-model overlay [i](#)

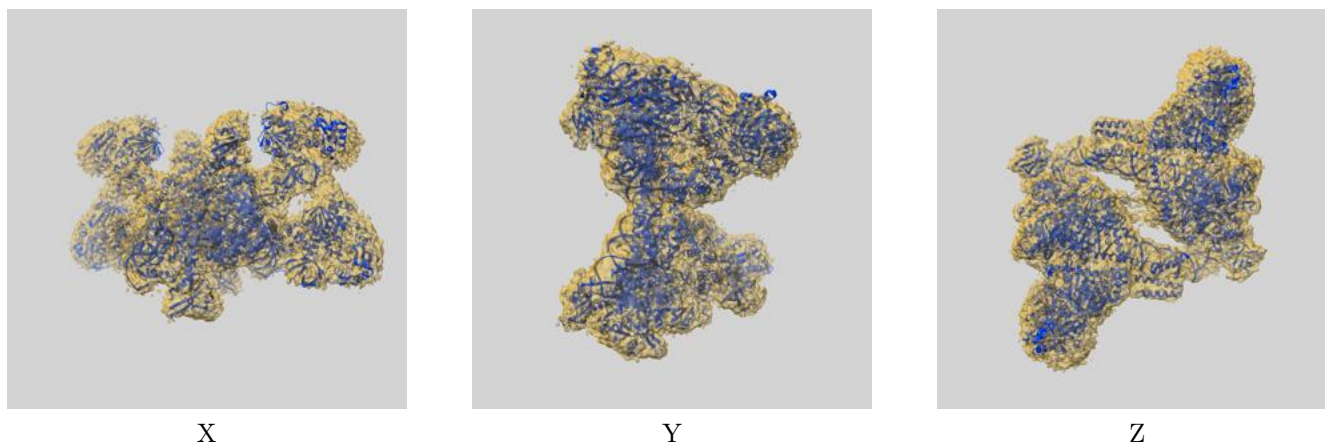

The images above show the 3D surface view of the map at the recommended contour level 0.12 at 50% transparency in yellow overlaid with a ribbon representation of the model coloured in blue. These images allow for the visual assessment of the quality of fit between the atomic model and the map.

9.2 Q-score mapped to coordinate model [i](#)

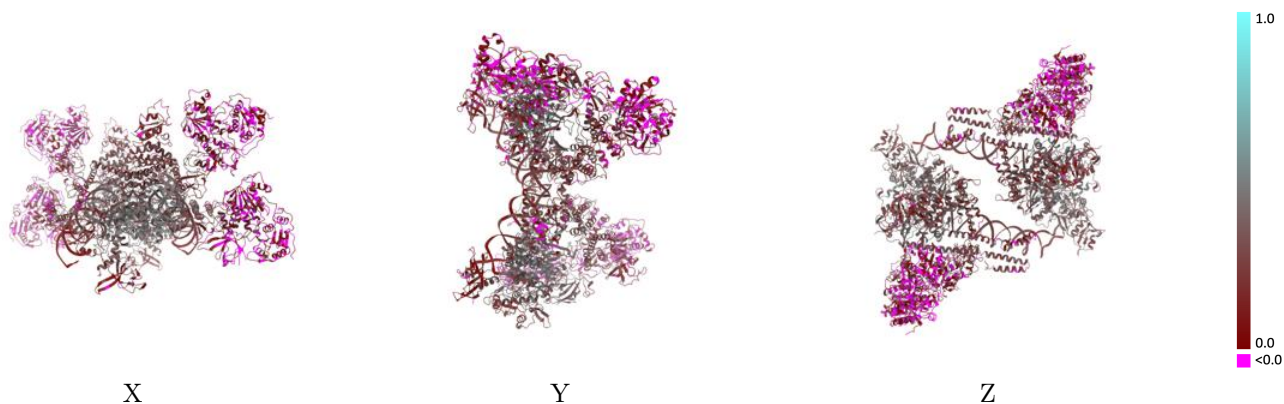

The images above show the model with each residue coloured according to its Q-score. This shows their resolvability in the map with higher Q-score values reflecting better resolvability. Please note: Q-score is calculating the resolvability of atoms, and thus high values are only expected at resolutions at which atoms can be resolved. Low Q-score values may therefore be expected for many entries.

9.3 Atom inclusion mapped to coordinate model [i](#)

This section was not generated.



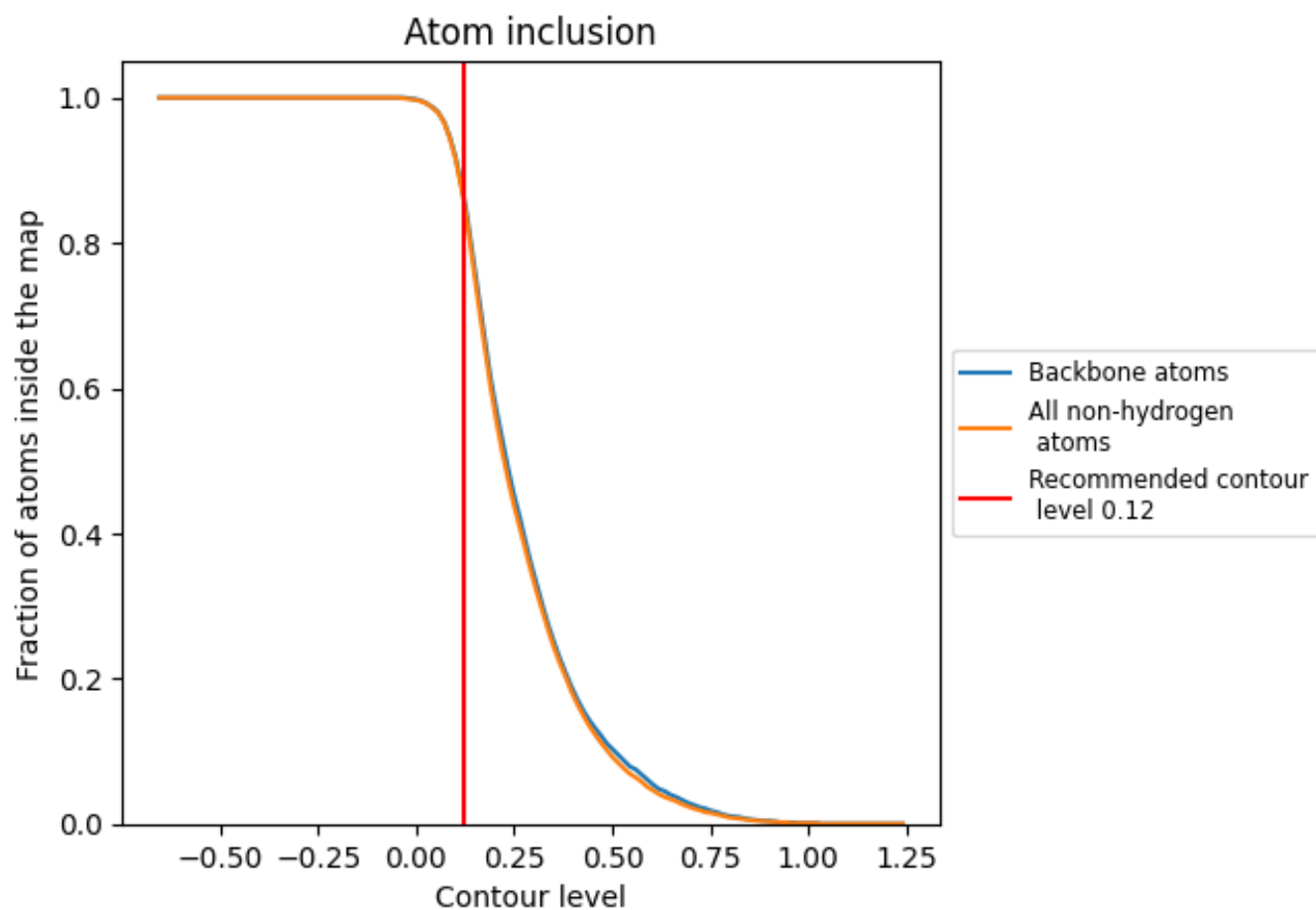



































9.4 Atom inclusion [i](#)



At the recommended contour level, 87% of all backbone atoms, 86% of all non-hydrogen atoms, are inside the map.

9.5 Map-model fit summary

The table lists the average atom inclusion at the recommended contour level (0.12) and Q-score for the entire model and for each chain.

Chain	Atom inclusion	Q-score
All	 0.8640	 0.2340
A	 0.9660	 0.3870
B	 0.9700	 0.3290
C	 0.9400	 0.3010
D	 0.9030	 0.2140
E	 0.7230	 0.0890
F	 0.7350	 0.0880
G	 0.8880	 0.2190
H	 0.9660	 0.3860
I	 0.9710	 0.3310
J	 0.9380	 0.2950
K	 0.8980	 0.2130
L	 0.7230	 0.0900
M	 0.7370	 0.0900
N	 0.8800	 0.2180
O	 0.9940	 0.2620
P	 0.9940	 0.2610
Q	 0.9790	 0.2520
R	 0.9800	 0.2580

