



wwPDB X-ray Structure Validation Summary Report ⓘ

Mar 9, 2026 – 07:15 AM UTC

PDB ID : 5JS9 / pdb_00005js9
Title : Uncleaved prefusion optimized gp140 trimer with an engineered 8-residue HR1 turn bound to broadly neutralizing antibodies 8ANC195 and PGT128
Authors : Kong, L.; Wilson, I.A.
Deposited on : 2016-05-07
Resolution : 6.92 Å (reported)

This is a wwPDB X-ray Structure Validation Summary Report for a publicly released PDB entry.

We welcome your comments at validation@mail.wwpdb.org

A user guide is available at

<https://www.wwpdb.org/validation/2017/XrayValidationReportHelp>

with specific help available everywhere you see the ⓘ symbol.

The types of validation reports are described at

<http://www.wwpdb.org/validation/2017/FAQs#types>.

The following versions of software and data (see [references ⓘ](#)) were used in the production of this report:

MolProbity : 4-5-2 with Phenix2.0
Mogul : 2022.3.0, CSD as543be (2022)
Xtriage (Phenix) : 2.0
EDS : 3.0
Percentile statistics : 20250101.v01 (using entries in the PDB archive January 1st 2025)
CCP4 : 9.0.010 (Gargrove)
Density-Fitness : 1.0.12
Ideal geometry (proteins) : Engh & Huber (2001)
Ideal geometry (DNA, RNA) : Parkinson et al. (1996)
Validation Pipeline (wwPDB-VP) : 2.49

1 Overall quality at a glance

The following experimental techniques were used to determine the structure:

X-RAY DIFFRACTION

The reported resolution of this entry is 6.92 Å.

Percentile scores (ranging between 0-100) for global validation metrics of the entry are shown in the following graphic. The table shows the number of entries on which the scores are based.

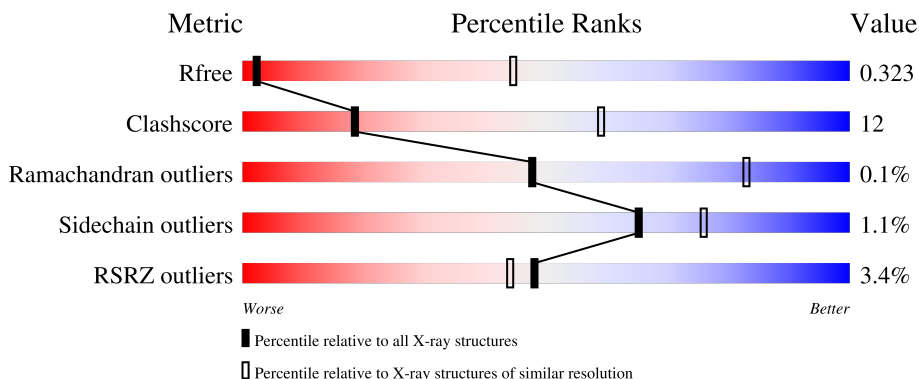

Metric	Whole archive (#Entries)	Similar resolution (#Entries, resolution range(Å))
R_{free}	180053	1166 (9.70-4.00)
Clashscore	190562	1007 (9.70-4.04)
Ramachandran outliers	187476	1053 (9.70-4.00)
Sidechain outliers	187428	1016 (9.70-4.00)
RSRZ outliers	180081	1159 (9.70-4.00)

The table below summarises the geometric issues observed across the polymeric chains and their fit to the electron density. The red, orange, yellow and green segments of the lower bar indicate the fraction of residues that contain outliers for ≥ 3 , 2, 1 and 0 types of geometric quality criteria respectively. A grey segment represents the fraction of residues that are not modelled. The numeric value for each fraction is indicated below the corresponding segment, with a dot representing fractions $\leq 5\%$. The upper red bar (where present) indicates the fraction of residues that have poor fit to the electron density. The numeric value is given above the bar.

Mol	Chain	Length	Quality of chain
1	A	239	 4% 74% 22%
2	B	211	 2% 69% 26%
3	C	480	 5% 67% 26% 7%
4	D	140	 4% 64% 28% 7%
5	E	238	 3% 69% 24% 6%

Continued on next page...

Continued from previous page...

Mol	Chain	Length	Quality of chain
6	F	215	
7	G	2	
7	H	2	
7	I	2	
7	J	2	
8	K	8	
9	L	10	
10	M	8	
11	N	5	
12	O	5	
13	P	3	
13	Q	3	
13	R	3	
14	S	11	
15	T	4	

The following table lists non-polymeric compounds, carbohydrate monomers and non-standard residues in protein, DNA, RNA chains that are outliers for geometric or electron-density-fit criteria:

Mol	Type	Chain	Res	Chirality	Geometry	Clashes	Electron density
14	MAN	S	11	-	-	X	-

2 Entry composition [i](#)

There are 16 unique types of molecules in this entry. The entry contains 12007 atoms, of which 0 are hydrogens and 0 are deuteriums.

In the tables below, the ZeroOcc column contains the number of atoms modelled with zero occupancy, the AltConf column contains the number of residues with at least one atom in alternate conformation and the Trace column contains the number of residues modelled with at most 2 atoms.

- Molecule 1 is a protein called broadly neutralizing antibody PGT128 heavy chain.

Mol	Chain	Residues	Atoms					ZeroOcc	AltConf	Trace
			Total	C	N	O	S			
1	A	230	1735	1105	292	332	6	0	0	0

- Molecule 2 is a protein called broadly neutralizing antibody PGT128 light chain.

Mol	Chain	Residues	Atoms					ZeroOcc	AltConf	Trace
			Total	C	N	O	S			
2	B	204	1514	950	254	306	4	0	0	0

- Molecule 3 is a protein called gp120.

Mol	Chain	Residues	Atoms					ZeroOcc	AltConf	Trace
			Total	C	N	O	S			
3	C	447	3519	2210	622	659	28	0	0	0

- Molecule 4 is a protein called gp41.

Mol	Chain	Residues	Atoms					ZeroOcc	AltConf	Trace
			Total	C	N	O	S			
4	D	130	1039	655	178	199	7	0	0	0

- Molecule 5 is a protein called broadly neutralizing antibody 8ANC195 heavy chain.

Mol	Chain	Residues	Atoms					ZeroOcc	AltConf	Trace
			Total	C	N	O	S			
5	E	224	1686	1072	284	325	5	0	0	0

- Molecule 6 is a protein called broadly neutralizing antibody 8ANC195 light chain.

Mol	Chain	Residues	Atoms					ZeroOcc	AltConf	Trace
			Total	C	N	O	S			
6	F	212	1626	1018	279	324	5	0	0	0

- Molecule 7 is an oligosaccharide called 2-acetamido-2-deoxy-beta-D-glucopyranose-(1-4)-2-acetamido-2-deoxy-beta-D-glucopyranose.



Mol	Chain	Residues	Atoms				ZeroOcc	AltConf	Trace
			Total	C	N	O			
7	G	2	28	16	2	10	0	0	0
7	H	2	28	16	2	10	0	0	0
7	I	2	28	16	2	10	0	0	0
7	J	2	28	16	2	10	0	0	0

- Molecule 8 is an oligosaccharide called alpha-D-mannopyranose-(1-2)-alpha-D-mannopyranose-(1-3)-[alpha-D-mannopyranose-(1-3)-[alpha-D-mannopyranose-(1-6)]alpha-D-mannopyranose-(1-6)]beta-D-mannopyranose-(1-4)-2-acetamido-2-deoxy-beta-D-glucopyranose-(1-4)-2-acetamido-2-deoxy-beta-D-glucopyranose.

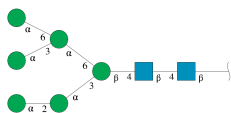

Mol	Chain	Residues	Atoms				ZeroOcc	AltConf	Trace
			Total	C	N	O			
8	K	8	94	52	2	40	0	0	0

- Molecule 9 is an oligosaccharide called alpha-D-mannopyranose-(1-2)-alpha-D-mannopyranose-(1-2)-alpha-D-mannopyranose-(1-3)-[alpha-D-mannopyranose-(1-2)-alpha-D-mannopyranose-(1-6)-[alpha-D-mannopyranose-(1-3)]alpha-D-mannopyranose-(1-6)]beta-D-mannopyranose-(1-4)-2-acetamido-2-deoxy-beta-D-glucopyranose-(1-4)-2-acetamido-2-deoxy-beta-D-glucopyranose.

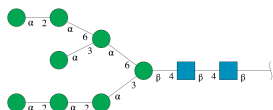

Mol	Chain	Residues	Atoms				ZeroOcc	AltConf	Trace
			Total	C	N	O			
9	L	10	116	64	2	50	0	0	0

- Molecule 10 is an oligosaccharide called alpha-D-mannopyranose-(1-2)-alpha-D-mannopyranose-(1-2)-alpha-D-mannopyranose-(1-3)-[alpha-D-mannopyranose-(1-3)-alpha-D-mannopyranose-(1-6)]beta-D-mannopyranose-(1-4)-2-acetamido-2-deoxy-beta-D-glucopyranose-(1-4)-2-acetamido-2-deoxy-beta-D-glucopyranose.

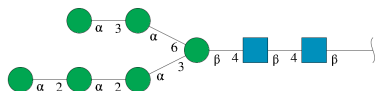

Mol	Chain	Residues	Atoms				ZeroOcc	AltConf	Trace
			Total	C	N	O			
10	M	8	94	52	2	40	0	0	0

- Molecule 11 is an oligosaccharide called alpha-D-mannopyranose-(1-3)-[alpha-D-mannopyranose-(1-6)]beta-D-mannopyranose-(1-4)-2-acetamido-2-deoxy-beta-D-glucopyranose-(1-4)-2-acetamido-2-deoxy-beta-D-glucopyranose.

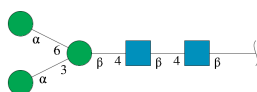

Mol	Chain	Residues	Atoms				ZeroOcc	AltConf	Trace
			Total	C	N	O			
11	N	5	61	34	2	25	0	0	0

- Molecule 12 is an oligosaccharide called alpha-D-mannopyranose-(1-2)-alpha-D-mannopyranose-(1-3)-beta-D-mannopyranose-(1-4)-2-acetamido-2-deoxy-beta-D-glucopyranose-(1-4)-2-acetamido-2-deoxy-beta-D-glucopyranose.

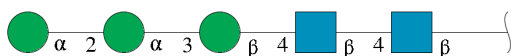

Mol	Chain	Residues	Atoms				ZeroOcc	AltConf	Trace
			Total	C	N	O			
12	O	5	61	34	2	25	0	0	0

- Molecule 13 is an oligosaccharide called beta-D-mannopyranose-(1-4)-2-acetamido-2-deoxy-beta-D-glucopyranose-(1-4)-2-acetamido-2-deoxy-beta-D-glucopyranose.

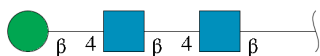

Mol	Chain	Residues	Atoms				ZeroOcc	AltConf	Trace
			Total	C	N	O			
13	P	3	39	22	2	15	0	0	0
13	Q	3	39	22	2	15	0	0	0
13	R	3	39	22	2	15	0	0	0

- Molecule 14 is an oligosaccharide called alpha-D-mannopyranose-(1-2)-alpha-D-mannopyranose-(1-2)-alpha-D-mannopyranose-(1-3)-[alpha-D-mannopyranose-(1-2)-alpha-D-mannopyranose-(1-3)-[alpha-D-mannopyranose-(1-2)-alpha-D-mannopyranose-(1-6)]alpha-D-mannopyranose-(1-6)]beta-D-mannopyranose-(1-4)-2-acetamido-2-deoxy-beta-D-glucopyranose-(1-4)-2-acetamido-2-deoxy-beta-D-glucopyranose.

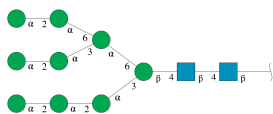

Mol	Chain	Residues	Atoms				ZeroOcc	AltConf	Trace
			Total	C	N	O			
14	S	11	127	70	2	55	0	0	0

- Molecule 15 is an oligosaccharide called alpha-D-mannopyranose-(1-6)-beta-D-mannopyranose-(1-4)-2-acetamido-2-deoxy-beta-D-glucopyranose-(1-4)-2-acetamido-2-deoxy-beta-D-glucopyranose.



Mol	Chain	Residues	Atoms				ZeroOcc	AltConf	Trace
			Total	C	N	O			
15	T	4	50	28	2	20	0	0	0

- Molecule 16 is 2-acetamido-2-deoxy-beta-D-glucopyranose (CCD ID: NAG) (formula: C₈H₁₅NO₆).

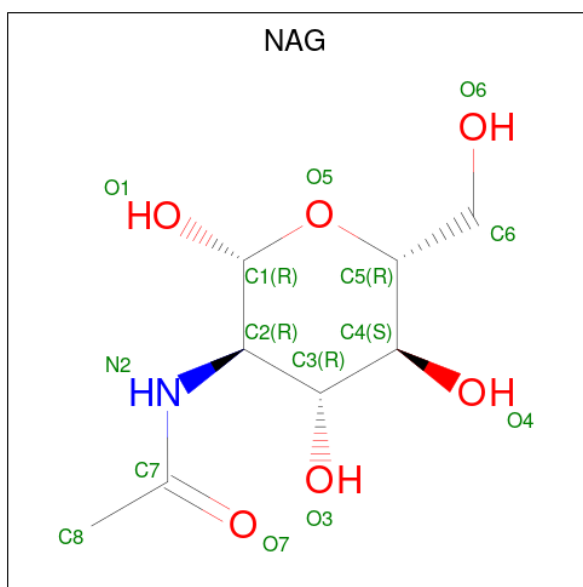

Mol	Chain	Residues	Atoms				ZeroOcc	AltConf
			Total	C	N	O		
16	C	1	Total 14	C 8	N 1	O 5	0	0
16	C	1	Total 14	C 8	N 1	O 5	0	0
16	C	1	Total 14	C 8	N 1	O 5	0	0
16	D	1	Total 14	C 8	N 1	O 5	0	0

3 Residue-property plots [i](#)

These plots are drawn for all protein, RNA, DNA and oligosaccharide chains in the entry. The first graphic for a chain summarises the proportions of the various outlier classes displayed in the second graphic. The second graphic shows the sequence view annotated by issues in geometry and electron density. Residues are color-coded according to the number of geometric quality criteria for which they contain at least one outlier: green = 0, yellow = 1, orange = 2 and red = 3 or more. A red dot above a residue indicates a poor fit to the electron density ($RSRZ > 2$). Stretches of 2 or more consecutive residues without any outlier are shown as a green connector. Residues present in the sample, but not in the model, are shown in grey.

- Molecule 1: broadly neutralizing antibody PGT128 heavy chain

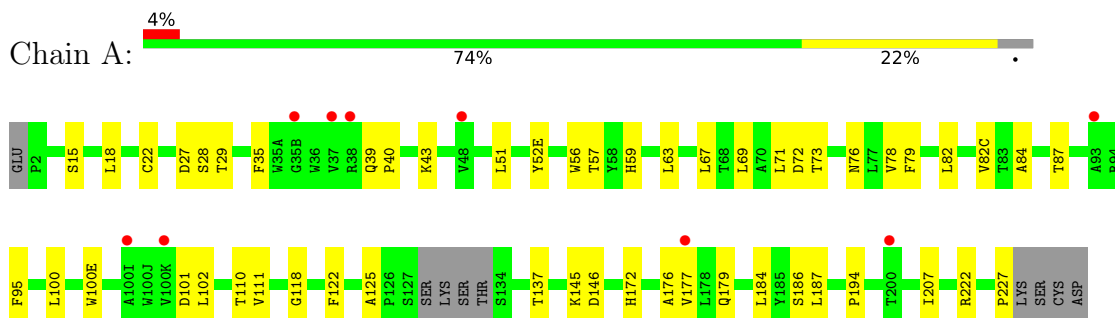

- Molecule 2: broadly neutralizing antibody PGT128 light chain

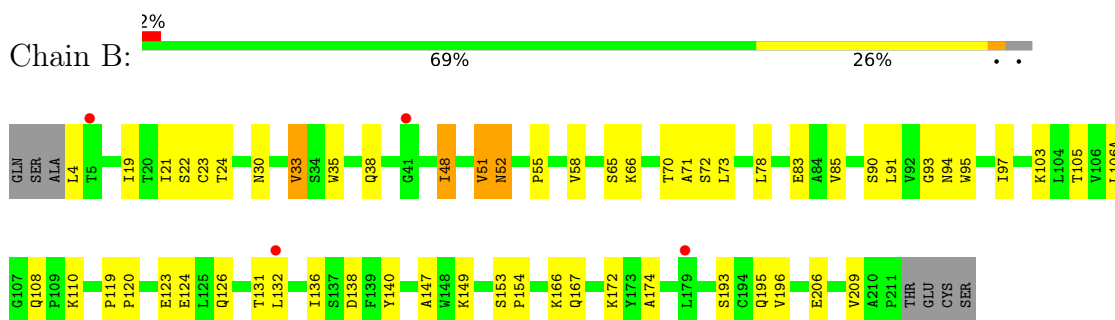

- Molecule 3: gp120

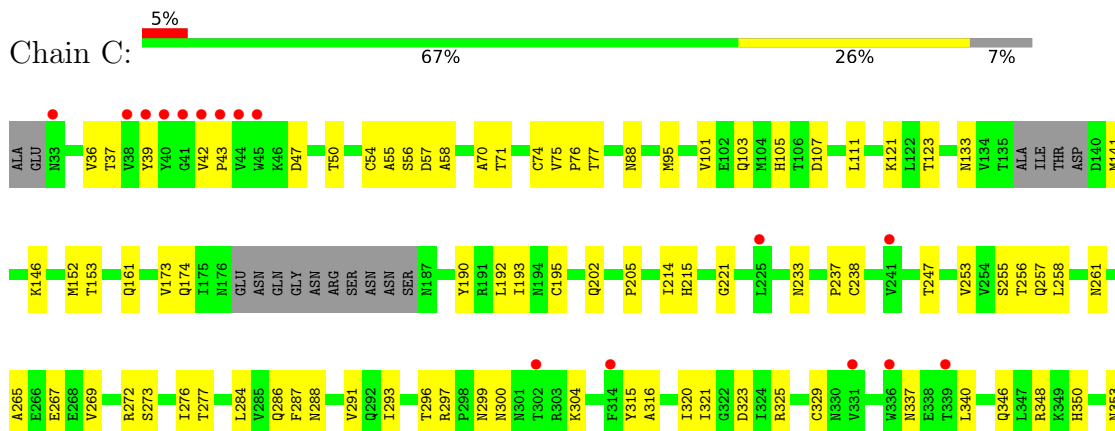

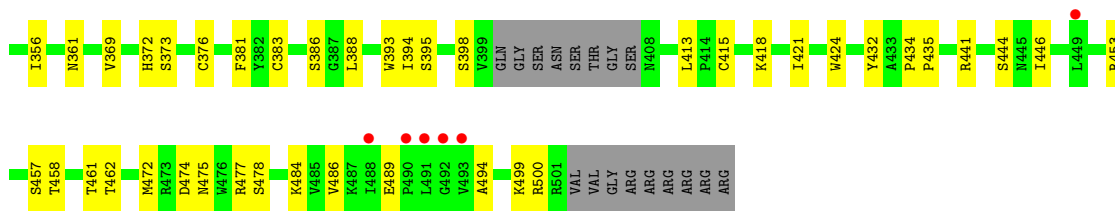

• Molecule 4: gp41

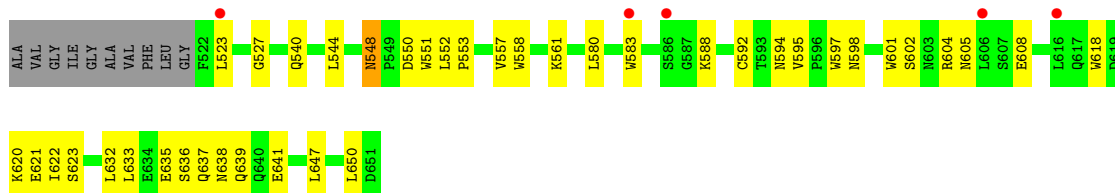

• Molecule 5: broadly neutralizing antibody 8ANC195 heavy chain

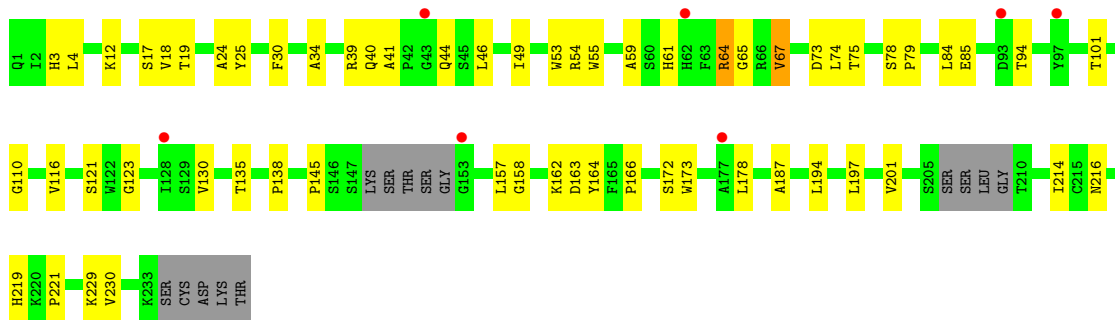

• Molecule 6: broadly neutralizing antibody 8ANC195 light chain

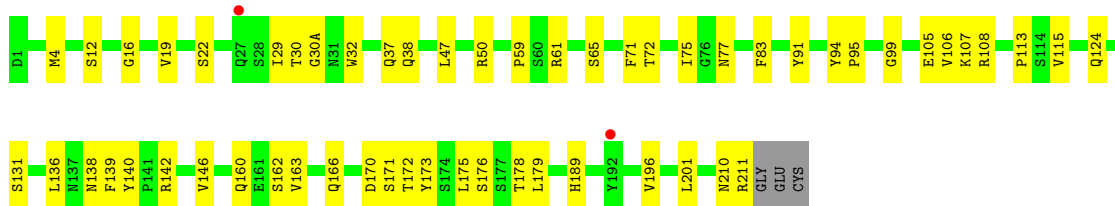

• Molecule 7: 2-acetamido-2-deoxy-beta-D-glucopyranose-(1-4)-2-acetamido-2-deoxy-beta-D-glucopyranose



- Molecule 7: 2-acetamido-2-deoxy-beta-D-glucopyranose-(1-4)-2-acetamido-2-deoxy-beta-D-glucopyranose

Chain H:  100%

MAG1
MAG2

- Molecule 7: 2-acetamido-2-deoxy-beta-D-glucopyranose-(1-4)-2-acetamido-2-deoxy-beta-D-glucopyranose

Chain I:  100%

MAG1
MAG2

- Molecule 7: 2-acetamido-2-deoxy-beta-D-glucopyranose-(1-4)-2-acetamido-2-deoxy-beta-D-glucopyranose

Chain J:  100%

MAG1
MAG2

- Molecule 8: alpha-D-mannopyranose-(1-2)-alpha-D-mannopyranose-(1-3)-[alpha-D-mannopyranose-(1-3)-[alpha-D-mannopyranose-(1-6)]alpha-D-mannopyranose-(1-6)]beta-D-mannopyranose-(1-4)-2-acetamido-2-deoxy-beta-D-glucopyranose-(1-4)-2-acetamido-2-deoxy-beta-D-glucopyranose

Chain K:  25% 75%

MAG1
MAG2
BMA3
MAN4
MAN5
MAN6
MAN7
MAN8

- Molecule 9: alpha-D-mannopyranose-(1-2)-alpha-D-mannopyranose-(1-2)-alpha-D-mannopyranose-(1-3)-[alpha-D-mannopyranose-(1-2)-alpha-D-mannopyranose-(1-6)-[alpha-D-mannopyranose-(1-3)]alpha-D-mannopyranose-(1-6)]beta-D-mannopyranose-(1-4)-2-acetamido-2-deoxy-beta-D-glucopyranose-(1-4)-2-acetamido-2-deoxy-beta-D-glucopyranose

Chain L:  30% 40% 30%

MAG1
MAG2
BMA3
MAN4
MAN5
MAN6
MAN7
MAN8
MAN9
MAN10

- Molecule 10: alpha-D-mannopyranose-(1-2)-alpha-D-mannopyranose-(1-2)-alpha-D-mannopyranose-(1-3)-[alpha-D-mannopyranose-(1-3)-alpha-D-mannopyranose-(1-6)]beta-D-mannopyranose-(1-4)-2-acetamido-2-deoxy-beta-D-glucopyranose-(1-4)-2-acetamido-2-deoxy-beta-D-glucopyranose

Chain M:  38% 62%



- Molecule 11: alpha-D-mannopyranose-(1-3)-[alpha-D-mannopyranose-(1-6)]beta-D-mannopyranose-(1-4)-2-acetamido-2-deoxy-beta-D-glucopyranose-(1-4)-2-acetamido-2-deoxy-beta-D-glucopyranose

Chain N: 100%



- Molecule 12: alpha-D-mannopyranose-(1-2)-alpha-D-mannopyranose-(1-3)-beta-D-mannopyranose-(1-4)-2-acetamido-2-deoxy-beta-D-glucopyranose-(1-4)-2-acetamido-2-deoxy-beta-D-glucopyranose

Chain O: 60% 40%



- Molecule 13: beta-D-mannopyranose-(1-4)-2-acetamido-2-deoxy-beta-D-glucopyranose-(1-4)-2-acetamido-2-deoxy-beta-D-glucopyranose

Chain P: 67% 33%



- Molecule 13: beta-D-mannopyranose-(1-4)-2-acetamido-2-deoxy-beta-D-glucopyranose-(1-4)-2-acetamido-2-deoxy-beta-D-glucopyranose

Chain Q: 100%



- Molecule 13: beta-D-mannopyranose-(1-4)-2-acetamido-2-deoxy-beta-D-glucopyranose-(1-4)-2-acetamido-2-deoxy-beta-D-glucopyranose

Chain R: 33% 67%



- Molecule 14: alpha-D-mannopyranose-(1-2)-alpha-D-mannopyranose-(1-2)-alpha-D-mannopyranose-(1-3)-[alpha-D-mannopyranose-(1-2)-alpha-D-mannopyranose-(1-6)]alpha-D-mannopyranose-(1-6)]beta-D-mannopyranose-(1-4)-2-acetamido-2-deoxy-beta-D-glucopyranose-(1-4)-2-acetamido-2-deoxy-beta-D-glucopyranose

Chain S: 9% 73% 18%



- Molecule 15: alpha-D-mannopyranose-(1-6)-beta-D-mannopyranose-(1-4)-2-acetamido-2-deoxy-beta-D-glucopyranose-(1-4)-2-acetamido-2-deoxy-beta-D-glucopyranose

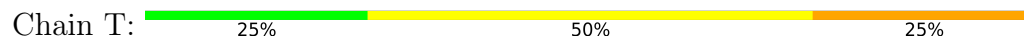

4 Data and refinement statistics

Property	Value	Source
Space group	I 2 3	Depositor
Cell constants a, b, c, α , β , γ	261.95Å 261.95Å 261.95Å 90.00° 90.00° 90.00°	Depositor
Resolution (Å)	47.83 – 6.92 47.83 – 6.92	Depositor EDS
% Data completeness (in resolution range)	99.8 (47.83-6.92) 90.6 (47.83-6.92)	Depositor EDS
R_{merge}	(Not available)	Depositor
R_{sym}	(Not available)	Depositor
$\langle I/\sigma(I) \rangle$ ¹	1.15 (at 6.68Å)	Xtrriage
Refinement program	PHENIX 1.9_1692	Depositor
R, R_{free}	0.284 , 0.322 0.296 , 0.323	Depositor DCC
R_{free} test set	493 reflections (9.78%)	wwPDB-VP
Wilson B-factor (Å ²)	334.1	Xtrriage
Anisotropy	0.000	Xtrriage
Bulk solvent k_{sol} (e/Å ³), B_{sol} (Å ²)	0.26 , 309.7	EDS
L-test for twinning ²	$\langle L \rangle = 0.44$, $\langle L^2 \rangle = 0.27$	Xtrriage
Estimated twinning fraction	0.067 for -l,-k,-h	Xtrriage
F_o, F_c correlation	0.83	EDS
Total number of atoms	12007	wwPDB-VP
Average B, all atoms (Å ²)	291.0	wwPDB-VP

Xtrriage's analysis on translational NCS is as follows: *The largest off-origin peak in the Patterson function is 3.07% of the height of the origin peak. No significant pseudotranslation is detected.*

¹Intensities estimated from amplitudes.

²Theoretical values of $\langle |L| \rangle$, $\langle L^2 \rangle$ for acentric reflections are 0.5, 0.333 respectively for untwinned datasets, and 0.375, 0.2 for perfectly twinned datasets.

5 Model quality [i](#)

5.1 Standard geometry [i](#)

Bond lengths and bond angles in the following residue types are not validated in this section: BMA, MAN, NAG

The Z score for a bond length (or angle) is the number of standard deviations the observed value is removed from the expected value. A bond length (or angle) with $|Z| > 5$ is considered an outlier worth inspection. RMSZ is the root-mean-square of all Z scores of the bond lengths (or angles).

Mol	Chain	Bond lengths		Bond angles	
		RMSZ	# Z >5	RMSZ	# Z >5
1	A	0.29	0/1786	0.76	2/2449 (0.1%)
2	B	0.29	0/1552	0.78	2/2121 (0.1%)
3	C	0.29	0/3592	0.78	6/4875 (0.1%)
4	D	0.34	0/1061	0.79	0/1444
5	E	0.29	0/1730	0.76	0/2361
6	F	0.29	0/1661	0.77	2/2256 (0.1%)
All	All	0.30	0/11382	0.77	12/15506 (0.1%)

There are no bond length outliers.

The worst 5 of 12 bond angle outliers are listed below:

Mol	Chain	Res	Type	Atoms	Z	Observed(°)	Ideal(°)
2	B	108	GLN	C-N-CD	-9.05	100.68	120.60
6	F	30(A)	GLY	N-CA-C	-8.05	104.74	115.21
3	C	123	THR	CA-C-N	-7.22	114.35	121.65
3	C	123	THR	C-N-CA	-7.22	114.35	121.65
1	A	118	GLY	CA-C-N	6.11	125.87	119.76

There are no chirality outliers.

There are no planarity outliers.

5.2 Too-close contacts [i](#)

In the following table, the Non-H and H(model) columns list the number of non-hydrogen atoms and hydrogen atoms in the chain respectively. The H(added) column lists the number of hydrogen atoms added and optimized by MolProbity. The Clashes column lists the number of clashes within the asymmetric unit, whereas Symm-Clashes lists symmetry-related clashes.

Mol	Chain	Non-H	H(model)	H(added)	Clashes	Symm-Clashes
1	A	1735	0	1690	33	0
2	B	1514	0	1473	40	0
3	C	3519	0	3460	103	0
4	D	1039	0	1003	41	0
5	E	1686	0	1659	54	0
6	F	1626	0	1581	41	0
7	G	28	0	25	2	0
7	H	28	0	25	0	0
7	I	28	0	25	1	0
7	J	28	0	25	2	0
8	K	94	0	79	2	0
9	L	116	0	97	5	0
10	M	94	0	79	0	0
11	N	61	0	52	3	0
12	O	61	0	52	0	0
13	P	39	0	34	1	0
13	Q	39	0	34	0	0
13	R	39	0	34	1	0
14	S	127	0	106	14	0
15	T	50	0	43	2	0
16	C	42	0	39	1	0
16	D	14	0	13	0	0
All	All	12007	0	11628	284	0

The all-atom clashscore is defined as the number of clashes found per 1000 atoms (including hydrogen atoms). The all-atom clashscore for this structure is 12.

The worst 5 of 284 close contacts within the same asymmetric unit are listed below, sorted by their clash magnitude.

Atom-1	Atom-2	Interatomic distance (Å)	Clash overlap (Å)
3:C:76:PRO:HD2	4:D:551:TRP:CE2	1.53	1.42
3:C:76:PRO:HG2	4:D:551:TRP:CZ2	1.53	1.41
3:C:76:PRO:HD2	4:D:551:TRP:NE1	1.44	1.31
3:C:76:PRO:CG	4:D:551:TRP:CZ2	2.26	1.18
3:C:76:PRO:HG2	4:D:551:TRP:CH2	1.80	1.15

There are no symmetry-related clashes.

5.3 Torsion angles [i](#)

5.3.1 Protein backbone [i](#)

In the following table, the Percentiles column shows the percent Ramachandran outliers of the chain as a percentile score with respect to all X-ray entries followed by that with respect to entries of similar resolution.

The Analysed column shows the number of residues for which the backbone conformation was analysed, and the total number of residues.

Mol	Chain	Analysed	Favoured	Allowed	Outliers	Percentiles	
1	A	226/239 (95%)	212 (94%)	14 (6%)	0	100	100
2	B	202/211 (96%)	193 (96%)	8 (4%)	1 (0%)	24	63
3	C	439/480 (92%)	417 (95%)	22 (5%)	0	100	100
4	D	128/140 (91%)	118 (92%)	10 (8%)	0	100	100
5	E	218/238 (92%)	209 (96%)	9 (4%)	0	100	100
6	F	210/215 (98%)	205 (98%)	5 (2%)	0	100	100
All	All	1423/1523 (93%)	1354 (95%)	68 (5%)	1 (0%)	48	83

All (1) Ramachandran outliers are listed below:

Mol	Chain	Res	Type
2	B	51	VAL

5.3.2 Protein sidechains [i](#)

In the following table, the Percentiles column shows the percent sidechain outliers of the chain as a percentile score with respect to all X-ray entries followed by that with respect to entries of similar resolution.

The Analysed column shows the number of residues for which the sidechain conformation was analysed, and the total number of residues.

Mol	Chain	Analysed	Rotameric	Outliers	Percentiles	
1	A	194/203 (96%)	194 (100%)	0	100	100
2	B	171/177 (97%)	166 (97%)	5 (3%)	37	58
3	C	399/426 (94%)	397 (100%)	2 (0%)	81	83
4	D	113/118 (96%)	111 (98%)	2 (2%)	51	68
5	E	192/204 (94%)	188 (98%)	4 (2%)	47	65
6	F	180/182 (99%)	179 (99%)	1 (1%)	78	83

Continued on next page...

Continued from previous page...

Mol	Chain	Analysed	Rotameric	Outliers	Percentiles
All	All	1249/1310 (95%)	1235 (99%)	14 (1%)	65 76

5 of 14 residues with a non-rotameric sidechain are listed below:

Mol	Chain	Res	Type
4	D	548	ASN
4	D	552	LEU
6	F	146	VAL
5	E	116	VAL
5	E	230	VAL

Sometimes sidechains can be flipped to improve hydrogen bonding and reduce clashes. 5 of 6 such sidechains are listed below:

Mol	Chain	Res	Type
5	E	40	GLN
5	E	51	GLN
6	F	90	GLN
3	C	459	ASN
1	A	211	ASN

5.3.3 RNA [i](#)

There are no RNA molecules in this entry.

5.4 Non-standard residues in protein, DNA, RNA chains [i](#)

There are no non-standard protein/DNA/RNA residues in this entry.

5.5 Carbohydrates [i](#)

68 monosaccharides are modelled in this entry.

In the following table, the Counts columns list the number of bonds (or angles) for which Mogul statistics could be retrieved, the number of bonds (or angles) that are observed in the model and the number of bonds (or angles) that are defined in the Chemical Component Dictionary. The Link column lists molecule types, if any, to which the group is linked. The Z score for a bond length (or angle) is the number of standard deviations the observed value is removed from the expected value. A bond length (or angle) with $|Z| > 2$ is considered an outlier worth inspection. RMSZ is the root-mean-square of all Z scores of the bond lengths (or angles).

Mol	Type	Chain	Res	Link	Bond lengths			Bond angles		
					Counts	RMSZ	# Z > 2	Counts	RMSZ	# Z > 2
7	NAG	G	1	3,7	14,14,15	0.30	0	17,19,21	0.59	0
7	NAG	G	2	7	14,14,15	0.20	0	17,19,21	0.40	0
7	NAG	H	1	3,7	14,14,15	0.22	0	17,19,21	0.45	0
7	NAG	H	2	7	14,14,15	0.29	0	17,19,21	0.43	0
7	NAG	I	1	3,7	14,14,15	0.23	0	17,19,21	1.08	1 (5%)
7	NAG	I	2	7	14,14,15	0.25	0	17,19,21	0.39	0
7	NAG	J	1	3,7	14,14,15	0.27	0	17,19,21	0.53	0
7	NAG	J	2	7	14,14,15	0.27	0	17,19,21	0.38	0
8	NAG	K	1	3,8	14,14,15	0.59	0	17,19,21	0.55	0
8	NAG	K	2	8	14,14,15	0.55	0	17,19,21	0.50	0
8	BMA	K	3	8	11,11,12	0.55	0	15,15,17	0.66	0
8	MAN	K	4	8	11,11,12	0.66	0	15,15,17	1.00	1 (6%)
8	MAN	K	5	8	11,11,12	0.57	0	15,15,17	1.01	1 (6%)
8	MAN	K	6	8	11,11,12	0.87	0	15,15,17	0.90	2 (13%)
8	MAN	K	7	8	11,11,12	0.64	0	15,15,17	1.00	2 (13%)
8	MAN	K	8	8	11,11,12	0.79	1 (9%)	15,15,17	1.44	2 (13%)
9	NAG	L	1	3,9	14,14,15	0.27	0	17,19,21	0.46	0
9	MAN	L	10	9	11,11,12	0.67	0	15,15,17	0.96	2 (13%)
9	NAG	L	2	9	14,14,15	0.23	0	17,19,21	0.41	0
9	BMA	L	3	9	11,11,12	0.78	0	15,15,17	0.81	0
9	MAN	L	4	9	11,11,12	0.74	1 (9%)	15,15,17	1.12	2 (13%)
9	MAN	L	5	9	11,11,12	0.68	0	15,15,17	1.11	2 (13%)
9	MAN	L	6	9	11,11,12	0.78	0	15,15,17	0.91	1 (6%)
9	MAN	L	7	9	11,11,12	0.68	0	15,15,17	1.04	2 (13%)
9	MAN	L	8	9	11,11,12	0.66	0	15,15,17	1.22	2 (13%)
9	MAN	L	9	9	11,11,12	0.66	0	15,15,17	0.88	1 (6%)
10	NAG	M	1	3,10	14,14,15	0.47	0	17,19,21	0.65	0
10	NAG	M	2	10	14,14,15	0.21	0	17,19,21	0.73	0
10	BMA	M	3	10	11,11,12	0.79	0	15,15,17	0.97	0
10	MAN	M	4	10	11,11,12	0.79	0	15,15,17	1.33	2 (13%)
10	MAN	M	5	10	11,11,12	0.62	0	15,15,17	1.13	2 (13%)
10	MAN	M	6	10	11,11,12	0.60	0	15,15,17	1.12	2 (13%)
10	MAN	M	7	10	11,11,12	0.69	0	15,15,17	0.95	2 (13%)
10	MAN	M	8	10	11,11,12	0.65	0	15,15,17	0.94	2 (13%)
11	NAG	N	1	3,11	14,14,15	0.31	0	17,19,21	0.47	0
11	NAG	N	2	11	14,14,15	0.44	0	17,19,21	0.54	0
11	BMA	N	3	11	11,11,12	0.65	0	15,15,17	0.88	1 (6%)
11	MAN	N	4	11	11,11,12	0.73	0	15,15,17	1.33	1 (6%)

Mol	Type	Chain	Res	Link	Bond lengths			Bond angles		
					Counts	RMSZ	# Z > 2	Counts	RMSZ	# Z > 2
11	MAN	N	5	11	11,11,12	0.75	1 (9%)	15,15,17	1.11	2 (13%)
12	NAG	O	1	3,12	14,14,15	0.42	0	17,19,21	0.47	0
12	NAG	O	2	12	14,14,15	0.22	0	17,19,21	0.62	0
12	BMA	O	3	12	11,11,12	0.64	0	15,15,17	1.11	1 (6%)
12	MAN	O	4	12	11,11,12	0.62	0	15,15,17	1.25	2 (13%)
12	MAN	O	5	12	11,11,12	0.22	0	15,15,17	0.48	0
13	NAG	P	1	3,13	14,14,15	0.38	0	17,19,21	0.42	0
13	NAG	P	2	13	14,14,15	0.29	0	17,19,21	0.63	0
13	BMA	P	3	13	11,11,12	0.63	0	15,15,17	0.71	0
13	NAG	Q	1	3,13	14,14,15	0.35	0	17,19,21	0.51	0
13	NAG	Q	2	13	14,14,15	0.41	0	17,19,21	0.63	0
13	BMA	Q	3	13	11,11,12	0.66	0	15,15,17	0.73	0
13	NAG	R	1	3,13	14,14,15	0.32	0	17,19,21	0.70	0
13	NAG	R	2	13	14,14,15	0.25	0	17,19,21	0.69	1 (5%)
13	BMA	R	3	13	11,11,12	0.64	0	15,15,17	0.69	0
14	NAG	S	1	3,14	14,14,15	0.17	0	17,19,21	0.40	0
14	MAN	S	10	14	11,11,12	0.63	0	15,15,17	1.13	2 (13%)
14	MAN	S	11	14	11,11,12	0.63	0	15,15,17	0.93	2 (13%)
14	NAG	S	2	14	14,14,15	0.38	0	17,19,21	0.47	0
14	BMA	S	3	14	11,11,12	0.51	0	15,15,17	0.67	0
14	MAN	S	4	14	11,11,12	0.53	0	15,15,17	1.10	2 (13%)
14	MAN	S	5	14	11,11,12	0.70	0	15,15,17	0.99	1 (6%)
14	MAN	S	6	14	11,11,12	0.52	0	15,15,17	0.98	2 (13%)
14	MAN	S	7	14	11,11,12	0.57	0	15,15,17	1.17	2 (13%)
14	MAN	S	8	14	11,11,12	0.83	0	15,15,17	1.36	3 (20%)
14	MAN	S	9	14	11,11,12	0.59	0	15,15,17	1.01	2 (13%)
15	NAG	T	1	4,15	14,14,15	0.24	0	17,19,21	0.42	0
15	NAG	T	2	15	14,14,15	0.44	0	17,19,21	1.61	3 (17%)
15	BMA	T	3	15	11,11,12	0.74	0	15,15,17	0.96	0
15	MAN	T	4	15	11,11,12	1.53	3 (27%)	15,15,17	1.25	2 (13%)

In the following table, the Chirals column lists the number of chiral outliers, the number of chiral centers analysed, the number of these observed in the model and the number defined in the Chemical Component Dictionary. Similar counts are reported in the Torsion and Rings columns. '-' means no outliers of that kind were identified.

Mol	Type	Chain	Res	Link	Chirals	Torsions	Rings
7	NAG	G	1	3,7	-	3/6/23/26	0/1/1/1
7	NAG	G	2	7	-	3/6/23/26	0/1/1/1

Continued on next page...

Continued from previous page...

Mol	Type	Chain	Res	Link	Chirals	Torsions	Rings
7	NAG	H	1	3,7	-	2/6/23/26	0/1/1/1
7	NAG	H	2	7	-	2/6/23/26	0/1/1/1
7	NAG	I	1	3,7	-	1/6/23/26	0/1/1/1
7	NAG	I	2	7	-	0/6/23/26	0/1/1/1
7	NAG	J	1	3,7	-	3/6/23/26	0/1/1/1
7	NAG	J	2	7	-	1/6/23/26	0/1/1/1
8	NAG	K	1	3,8	-	2/6/23/26	0/1/1/1
8	NAG	K	2	8	-	2/6/23/26	0/1/1/1
8	BMA	K	3	8	-	0/2/19/22	0/1/1/1
8	MAN	K	4	8	-	0/2/19/22	0/1/1/1
8	MAN	K	5	8	-	0/2/19/22	0/1/1/1
8	MAN	K	6	8	-	2/2/19/22	0/1/1/1
8	MAN	K	7	8	-	0/2/19/22	0/1/1/1
8	MAN	K	8	8	-	0/2/19/22	0/1/1/1
9	NAG	L	1	3,9	-	0/6/23/26	0/1/1/1
9	MAN	L	10	9	-	1/2/19/22	0/1/1/1
9	NAG	L	2	9	-	2/6/23/26	0/1/1/1
9	BMA	L	3	9	-	0/2/19/22	0/1/1/1
9	MAN	L	4	9	-	1/2/19/22	0/1/1/1
9	MAN	L	5	9	-	0/2/19/22	0/1/1/1
9	MAN	L	6	9	-	0/2/19/22	0/1/1/1
9	MAN	L	7	9	-	0/2/19/22	0/1/1/1
9	MAN	L	8	9	-	0/2/19/22	0/1/1/1
9	MAN	L	9	9	-	0/2/19/22	0/1/1/1
10	NAG	M	1	3,10	-	2/6/23/26	0/1/1/1
10	NAG	M	2	10	-	2/6/23/26	0/1/1/1
10	BMA	M	3	10	-	0/2/19/22	0/1/1/1
10	MAN	M	4	10	-	0/2/19/22	0/1/1/1
10	MAN	M	5	10	-	0/2/19/22	0/1/1/1
10	MAN	M	6	10	-	0/2/19/22	0/1/1/1
10	MAN	M	7	10	-	0/2/19/22	0/1/1/1
10	MAN	M	8	10	-	0/2/19/22	0/1/1/1
11	NAG	N	1	3,11	-	0/6/23/26	0/1/1/1
11	NAG	N	2	11	-	0/6/23/26	0/1/1/1
11	BMA	N	3	11	-	0/2/19/22	0/1/1/1
11	MAN	N	4	11	-	1/2/19/22	0/1/1/1
11	MAN	N	5	11	-	0/2/19/22	0/1/1/1
12	NAG	O	1	3,12	-	0/6/23/26	0/1/1/1
12	NAG	O	2	12	-	2/6/23/26	0/1/1/1
12	BMA	O	3	12	-	0/2/19/22	0/1/1/1

Continued on next page...

Continued from previous page...

Mol	Type	Chain	Res	Link	Chirals	Torsions	Rings
12	MAN	O	4	12	-	2/2/19/22	0/1/1/1
12	MAN	O	5	12	-	0/2/19/22	0/1/1/1
13	NAG	P	1	3,13	-	1/6/23/26	0/1/1/1
13	NAG	P	2	13	-	1/6/23/26	0/1/1/1
13	BMA	P	3	13	-	0/2/19/22	0/1/1/1
13	NAG	Q	1	3,13	-	0/6/23/26	0/1/1/1
13	NAG	Q	2	13	-	2/6/23/26	0/1/1/1
13	BMA	Q	3	13	-	0/2/19/22	0/1/1/1
13	NAG	R	1	3,13	-	3/6/23/26	0/1/1/1
13	NAG	R	2	13	-	0/6/23/26	0/1/1/1
13	BMA	R	3	13	-	0/2/19/22	0/1/1/1
14	NAG	S	1	3,14	-	2/6/23/26	0/1/1/1
14	MAN	S	10	14	-	2/2/19/22	0/1/1/1
14	MAN	S	11	14	-	2/2/19/22	0/1/1/1
14	NAG	S	2	14	-	2/6/23/26	0/1/1/1
14	BMA	S	3	14	-	0/2/19/22	0/1/1/1
14	MAN	S	4	14	-	0/2/19/22	0/1/1/1
14	MAN	S	5	14	-	2/2/19/22	0/1/1/1
14	MAN	S	6	14	-	0/2/19/22	0/1/1/1
14	MAN	S	7	14	-	0/2/19/22	0/1/1/1
14	MAN	S	8	14	-	0/2/19/22	0/1/1/1
14	MAN	S	9	14	-	1/2/19/22	0/1/1/1
15	NAG	T	1	4,15	-	1/6/23/26	0/1/1/1
15	NAG	T	2	15	-	6/6/23/26	0/1/1/1
15	BMA	T	3	15	-	2/2/19/22	0/1/1/1
15	MAN	T	4	15	-	2/2/19/22	0/1/1/1

The worst 5 of 6 bond length outliers are listed below:

Mol	Chain	Res	Type	Atoms	Z	Observed(Å)	Ideal(Å)
15	T	4	MAN	C2-C3	2.94	1.57	1.52
15	T	4	MAN	O2-C2	2.78	1.49	1.43
15	T	4	MAN	C1-C2	2.52	1.58	1.52
11	N	5	MAN	C1-C2	2.23	1.57	1.52
8	K	8	MAN	C1-C2	2.13	1.57	1.52

The worst 5 of 60 bond angle outliers are listed below:

Mol	Chain	Res	Type	Atoms	Z	Observed(°)	Ideal(°)
15	T	2	NAG	C2-N2-C7	4.78	129.31	122.90

Continued on next page...

Continued from previous page...

Mol	Chain	Res	Type	Atoms	Z	Observed(°)	Ideal(°)
8	K	8	MAN	C1-O5-C5	4.69	118.47	112.19
11	N	4	MAN	C1-O5-C5	4.52	118.25	112.19
10	M	4	MAN	C1-O5-C5	4.39	118.07	112.19
10	M	5	MAN	C1-O5-C5	3.50	116.88	112.19

There are no chirality outliers.

5 of 63 torsion outliers are listed below:

Mol	Chain	Res	Type	Atoms
7	G	1	NAG	C3-C2-N2-C7
7	G	1	NAG	C8-C7-N2-C2
7	G	1	NAG	O7-C7-N2-C2
7	I	1	NAG	C3-C2-N2-C7
13	R	1	NAG	C8-C7-N2-C2

There are no ring outliers.

18 monomers are involved in 31 short contacts:

Mol	Chain	Res	Type	Clashes	Symm-Clashes
8	K	2	NAG	2	0
14	S	6	MAN	3	0
13	P	2	NAG	1	0
9	L	5	MAN	2	0
7	I	2	NAG	1	0
11	N	2	NAG	2	0
14	S	11	MAN	8	0
13	R	1	NAG	1	0
15	T	3	BMA	1	0
14	S	1	NAG	1	0
7	G	1	NAG	2	0
7	J	2	NAG	1	0
7	J	1	NAG	2	0
9	L	9	MAN	1	0
14	S	2	NAG	2	0
15	T	2	NAG	2	0
11	N	1	NAG	3	0
9	L	6	MAN	2	0

The following is a two-dimensional graphical depiction of Mogul quality analysis of bond lengths, bond angles, torsion angles, and ring geometry for oligosaccharide.

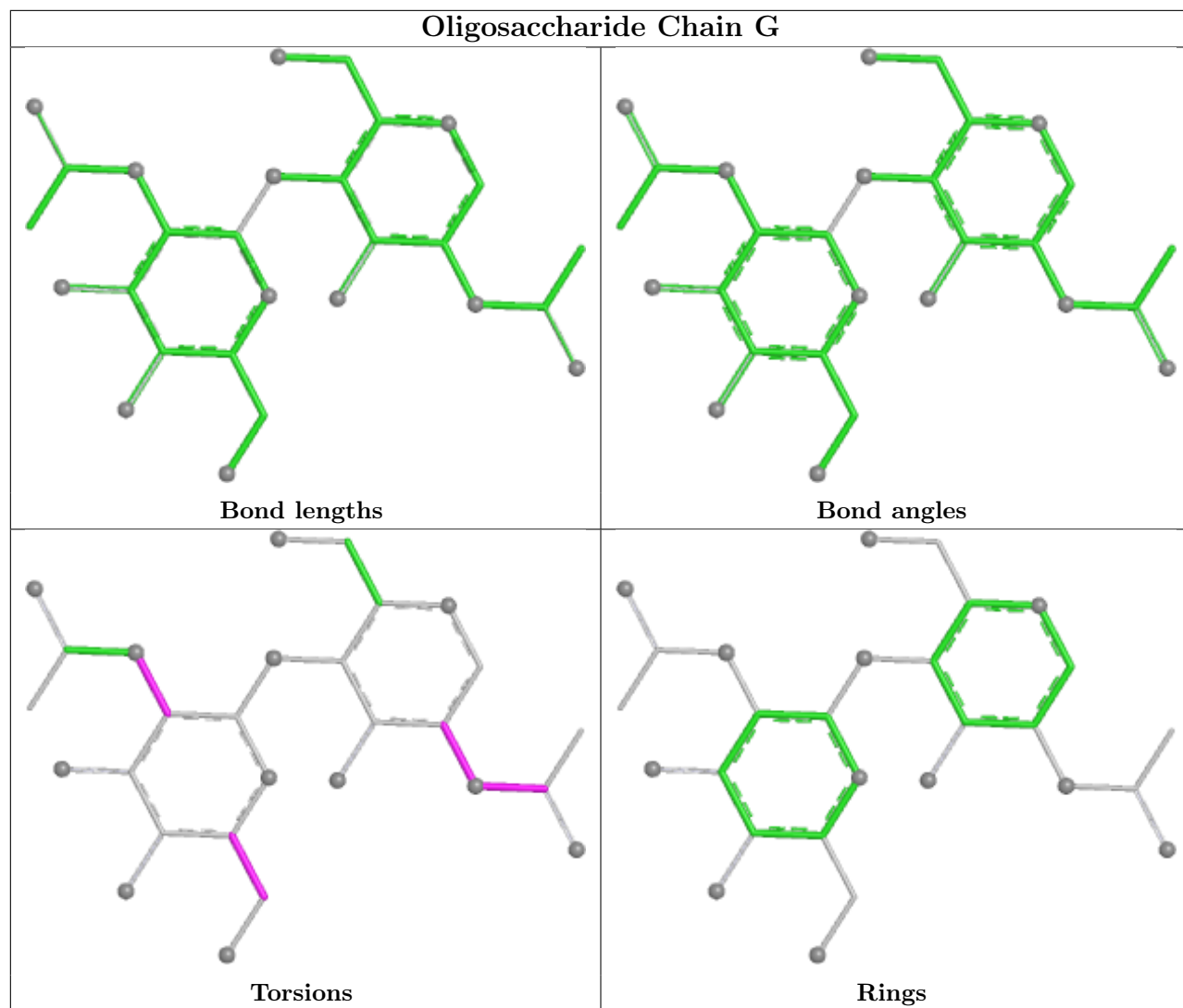

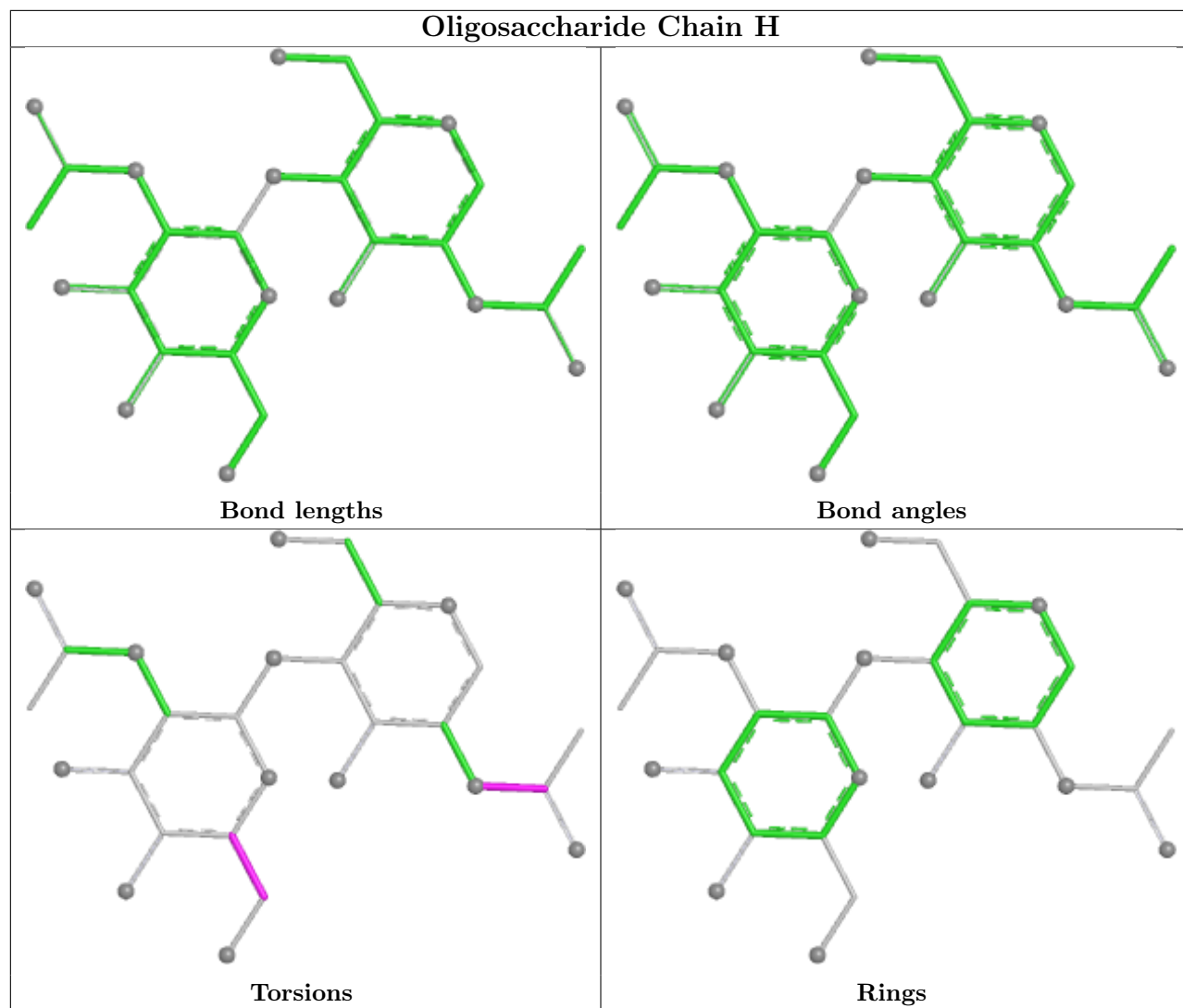

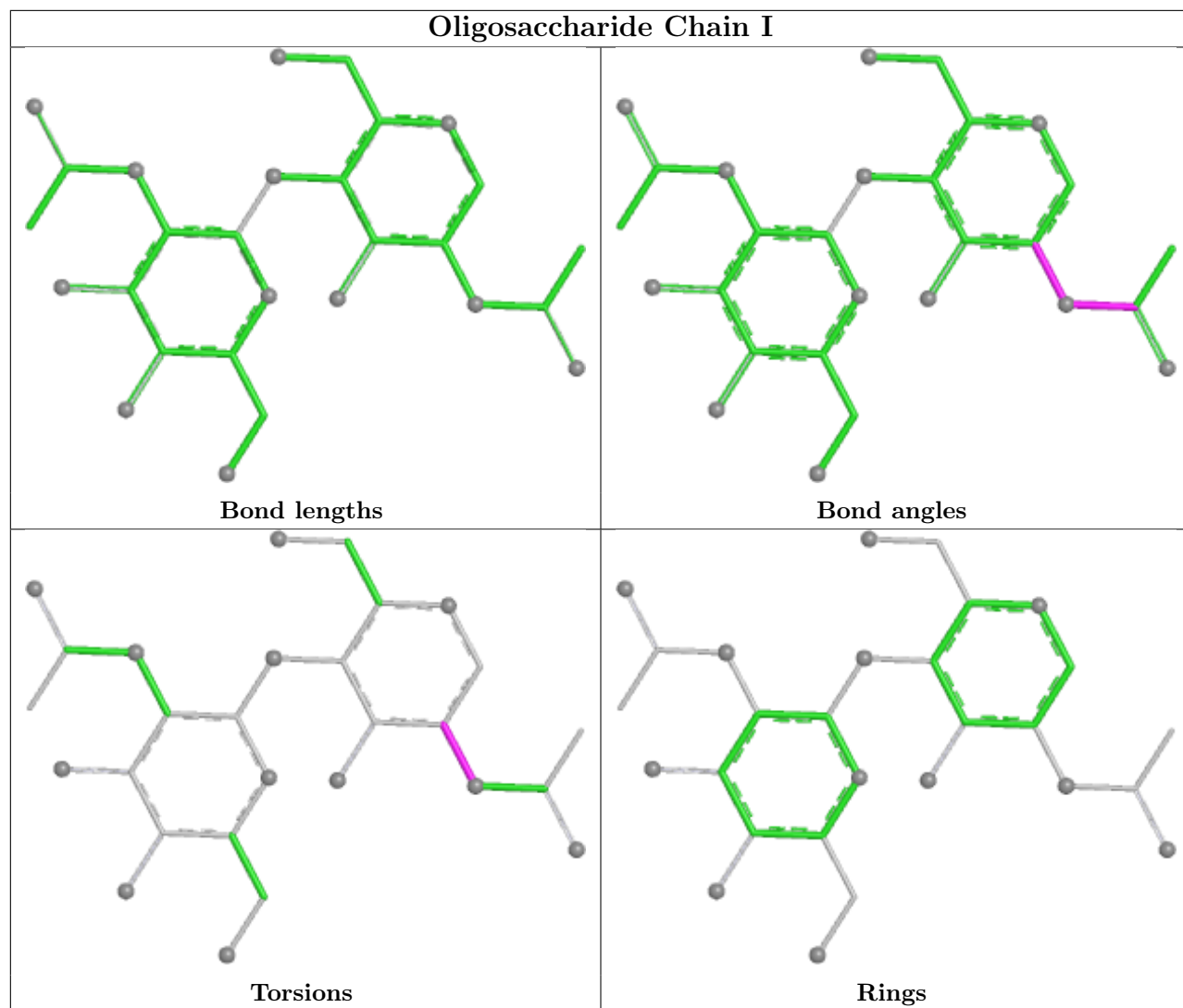

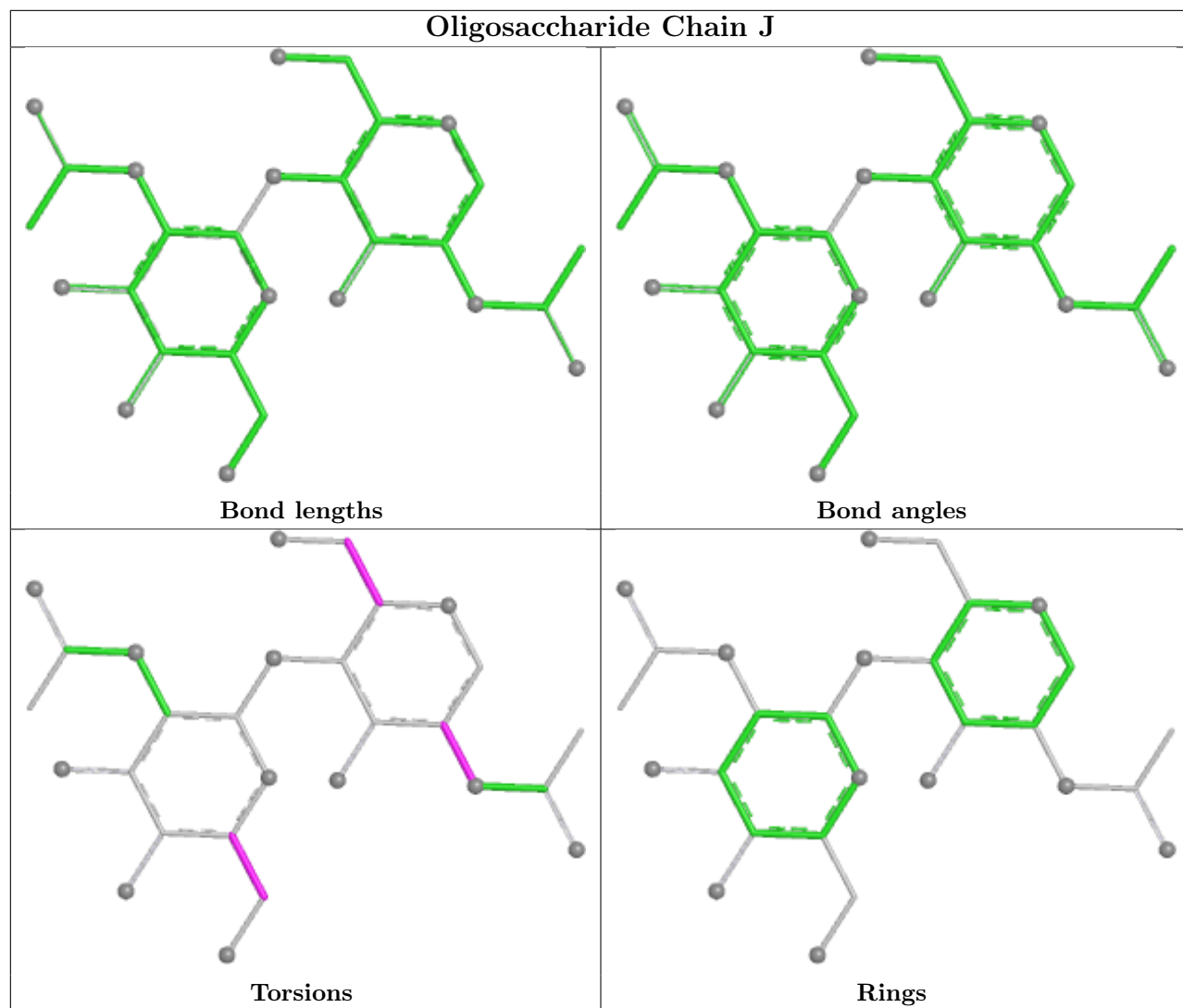

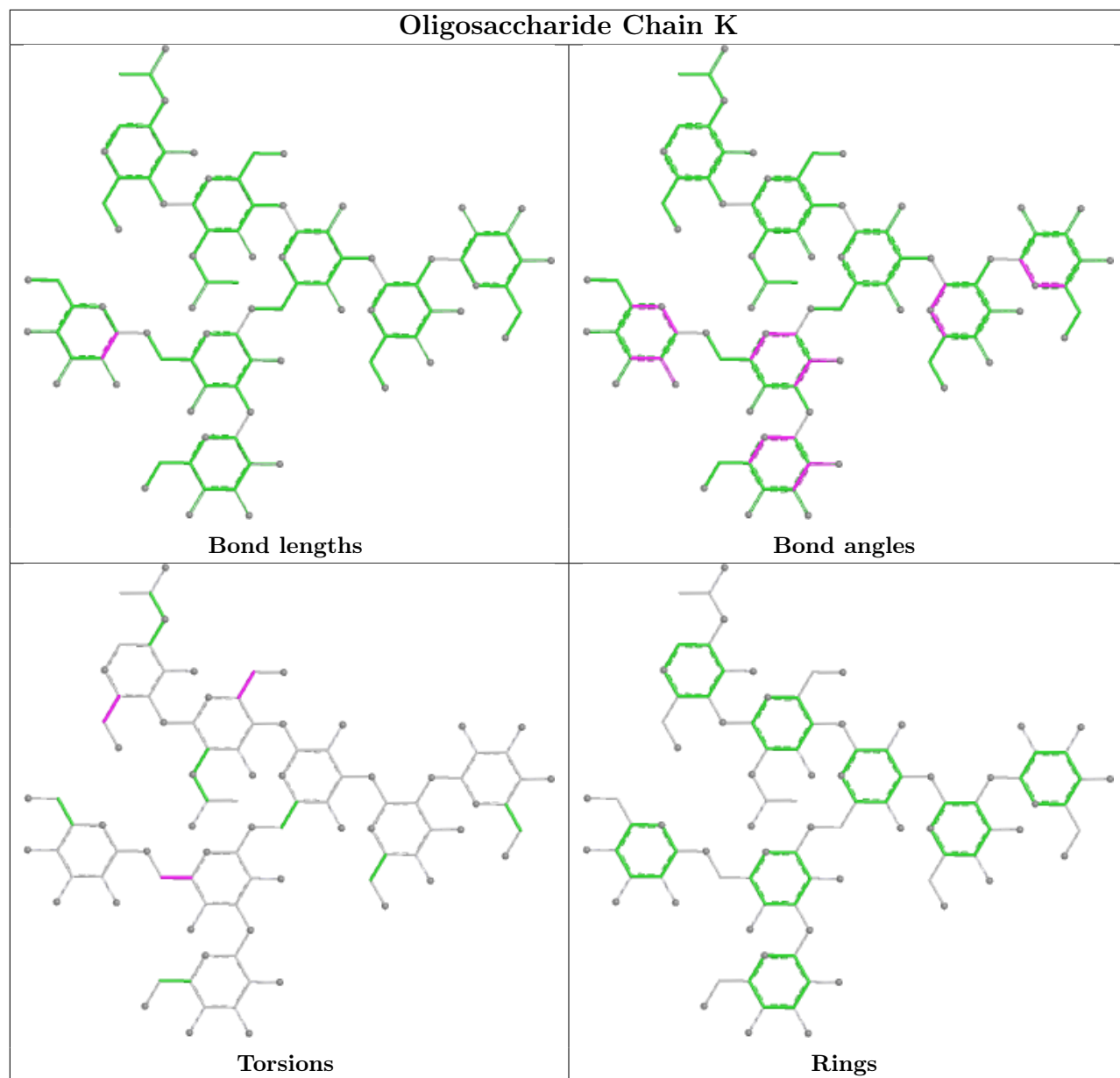

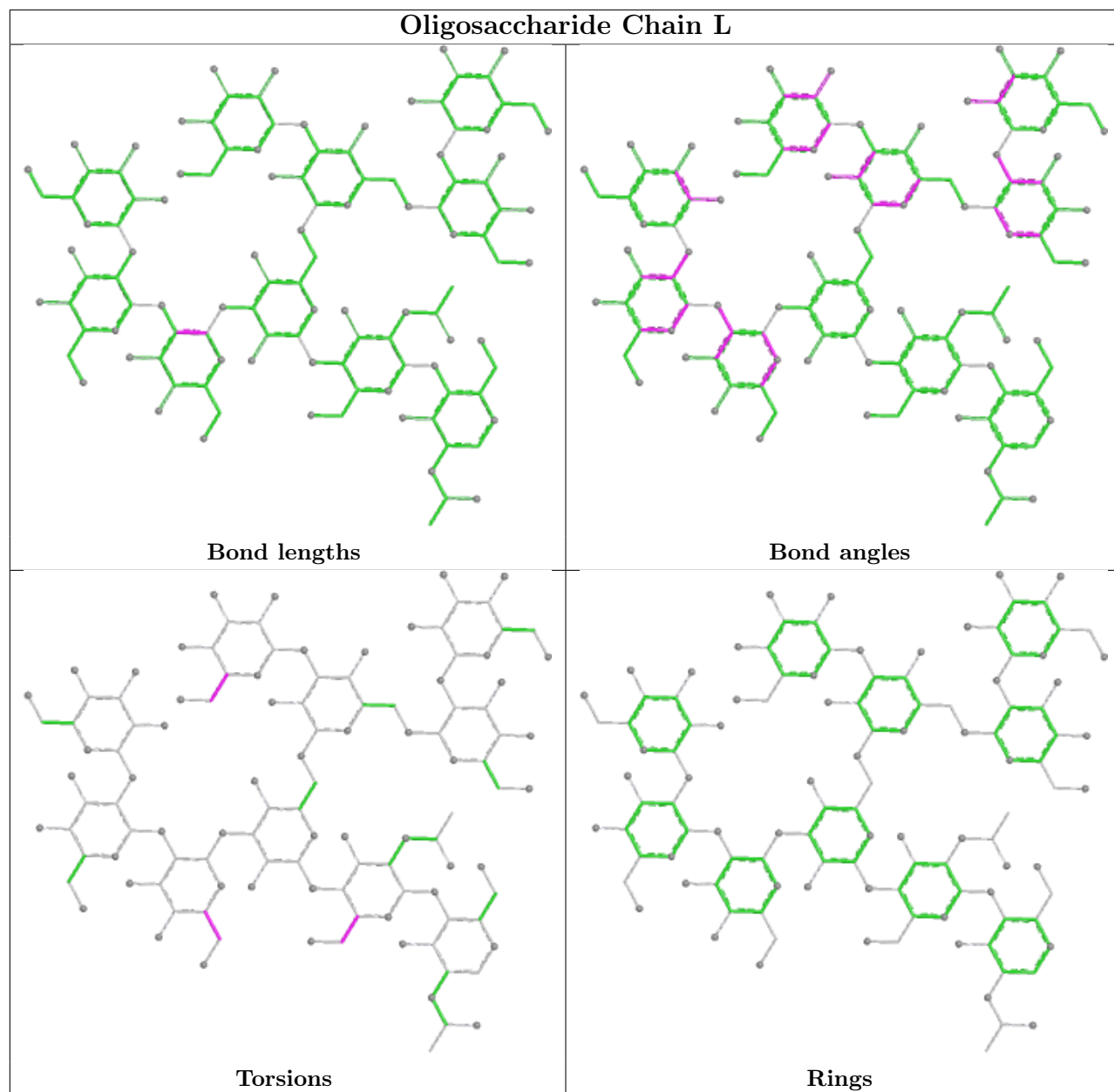

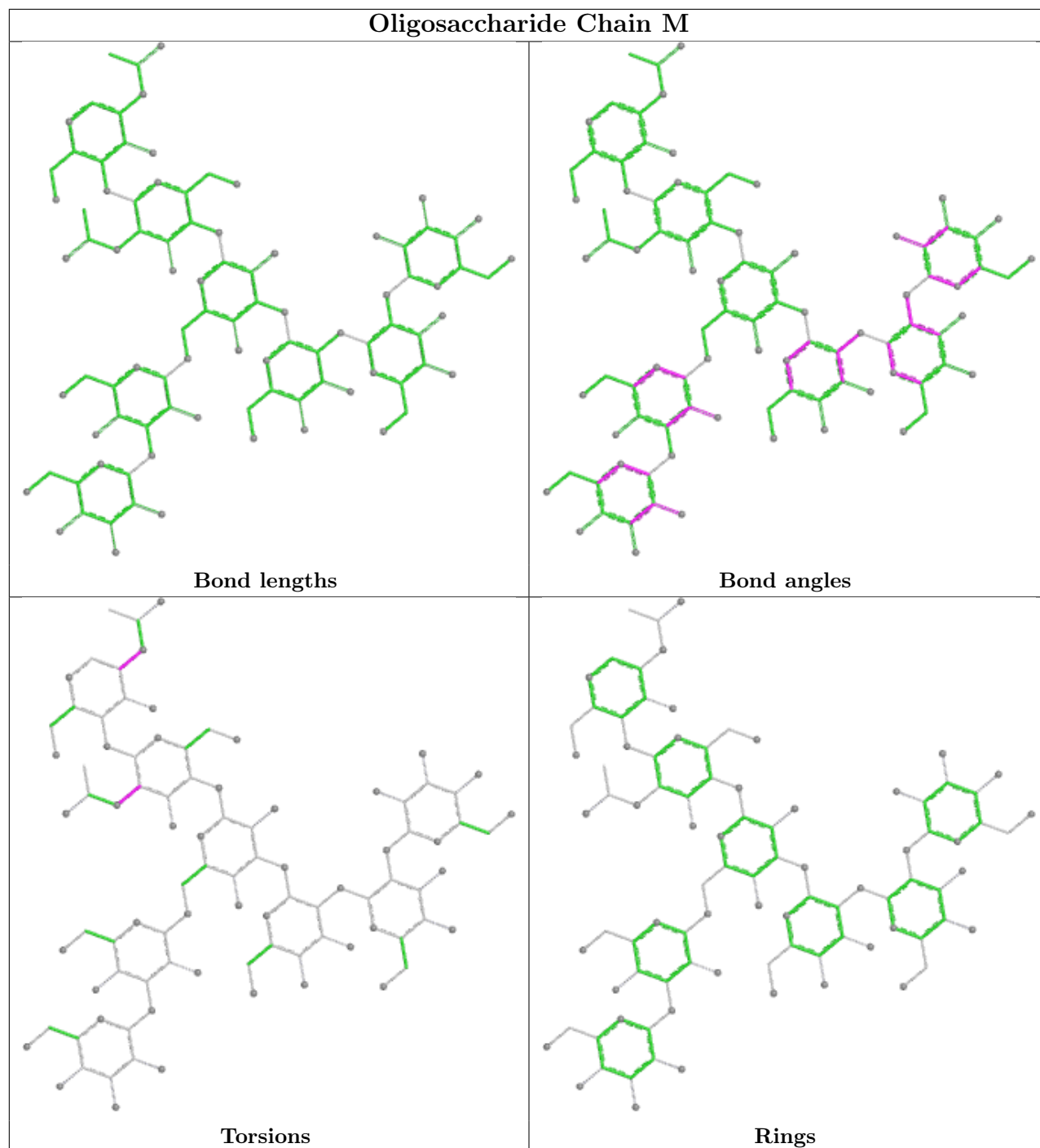

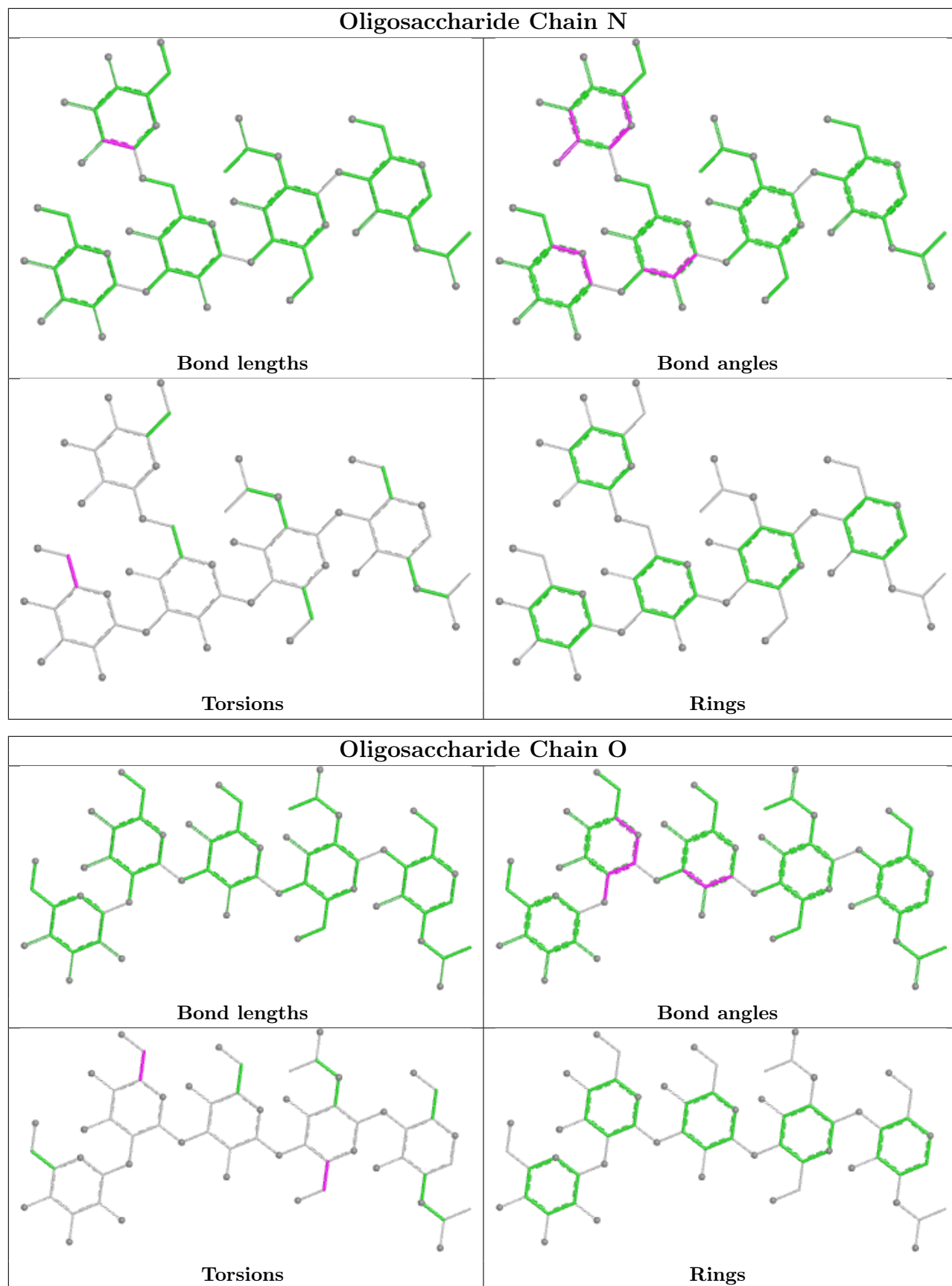

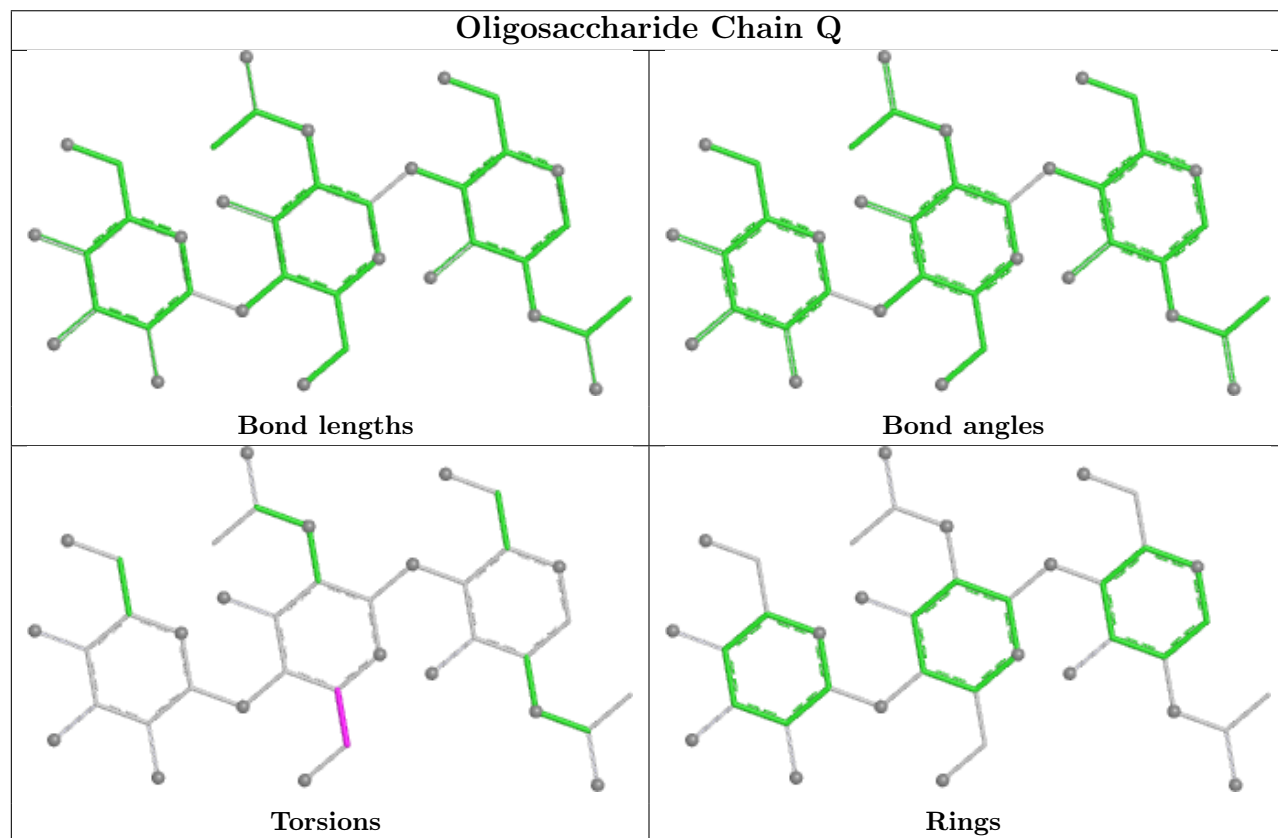
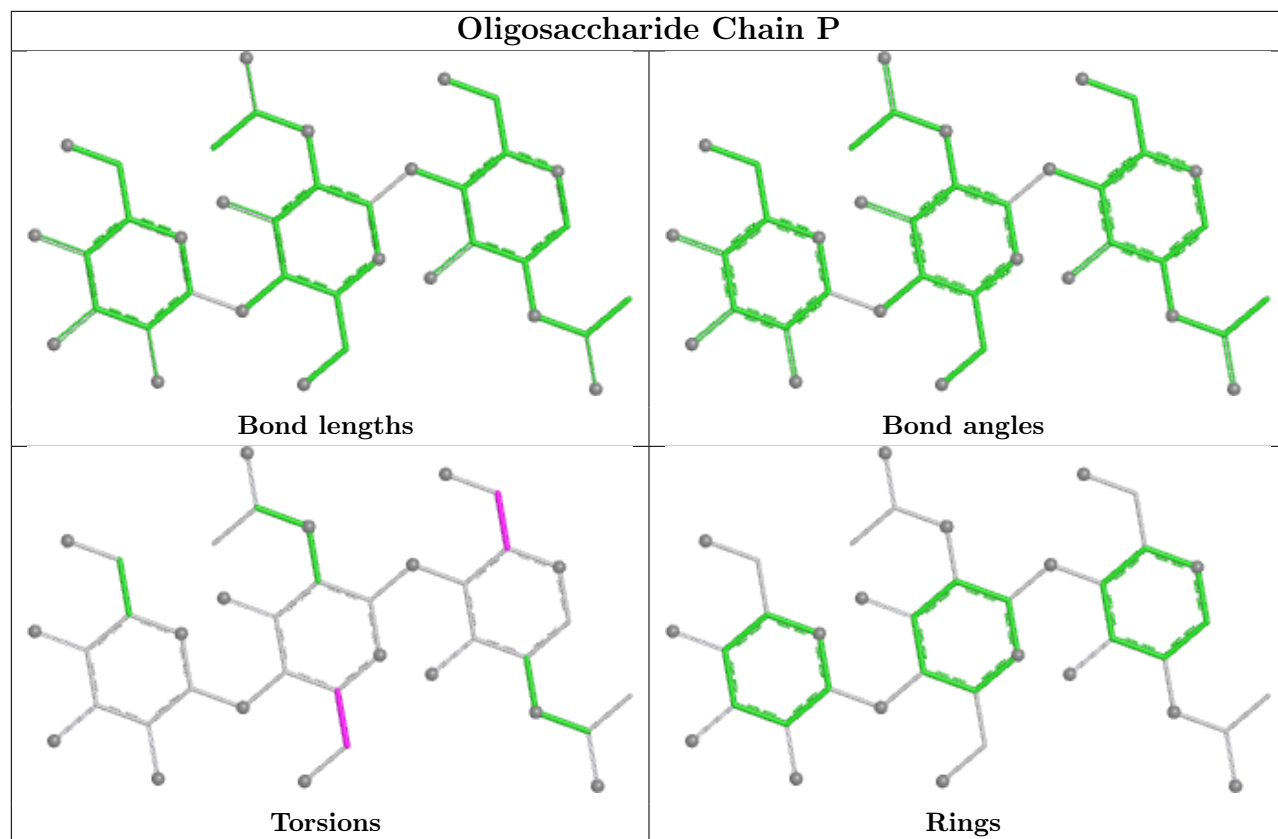

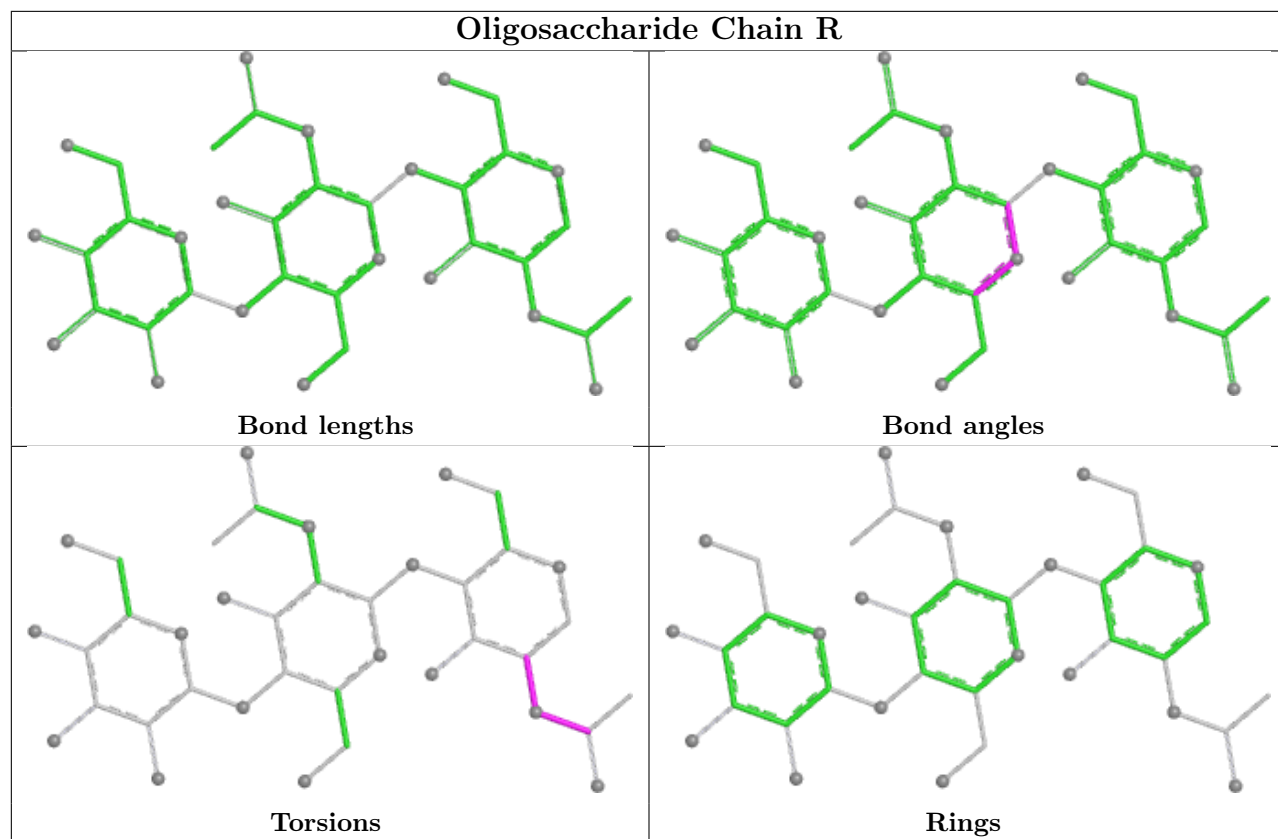

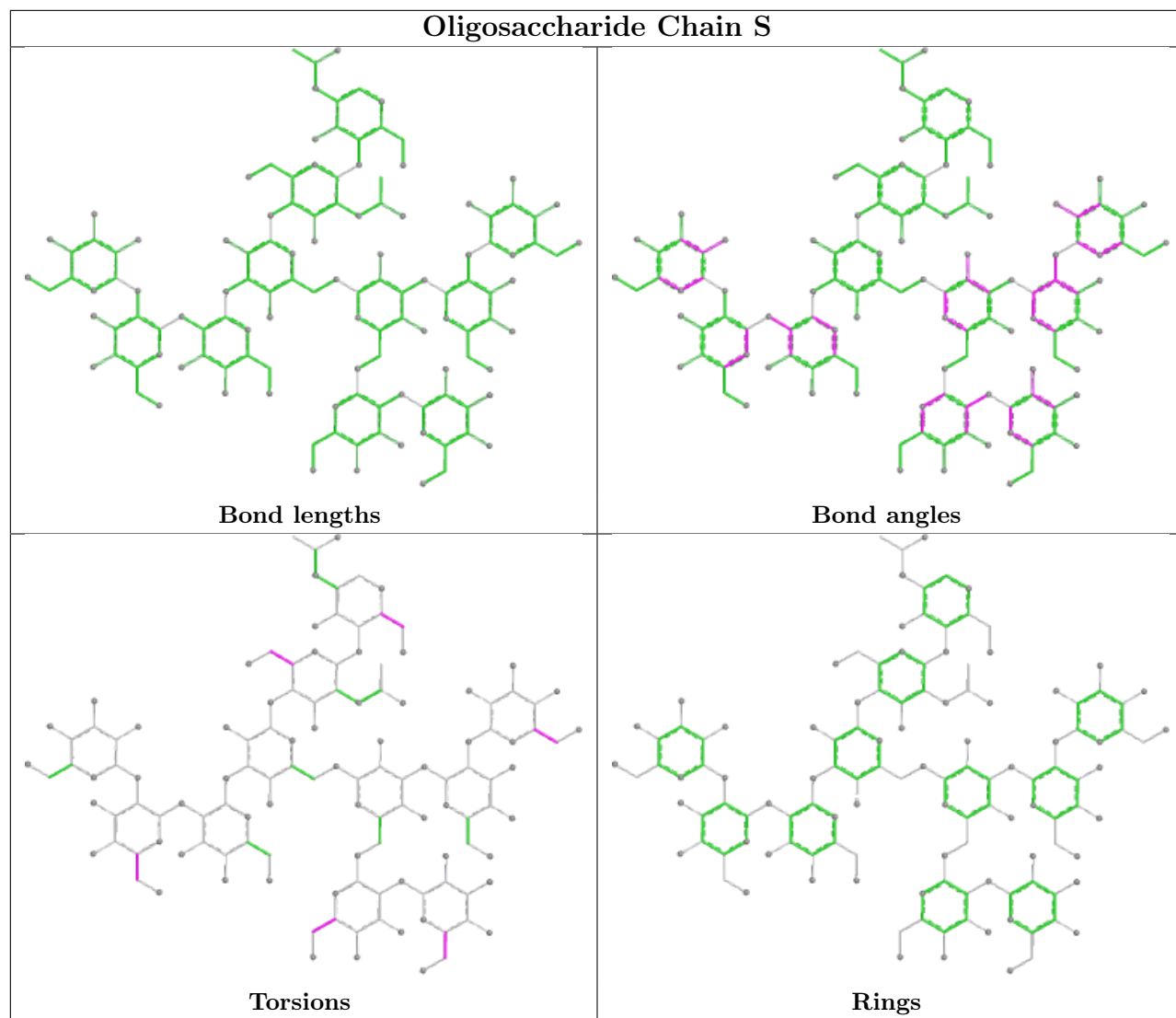

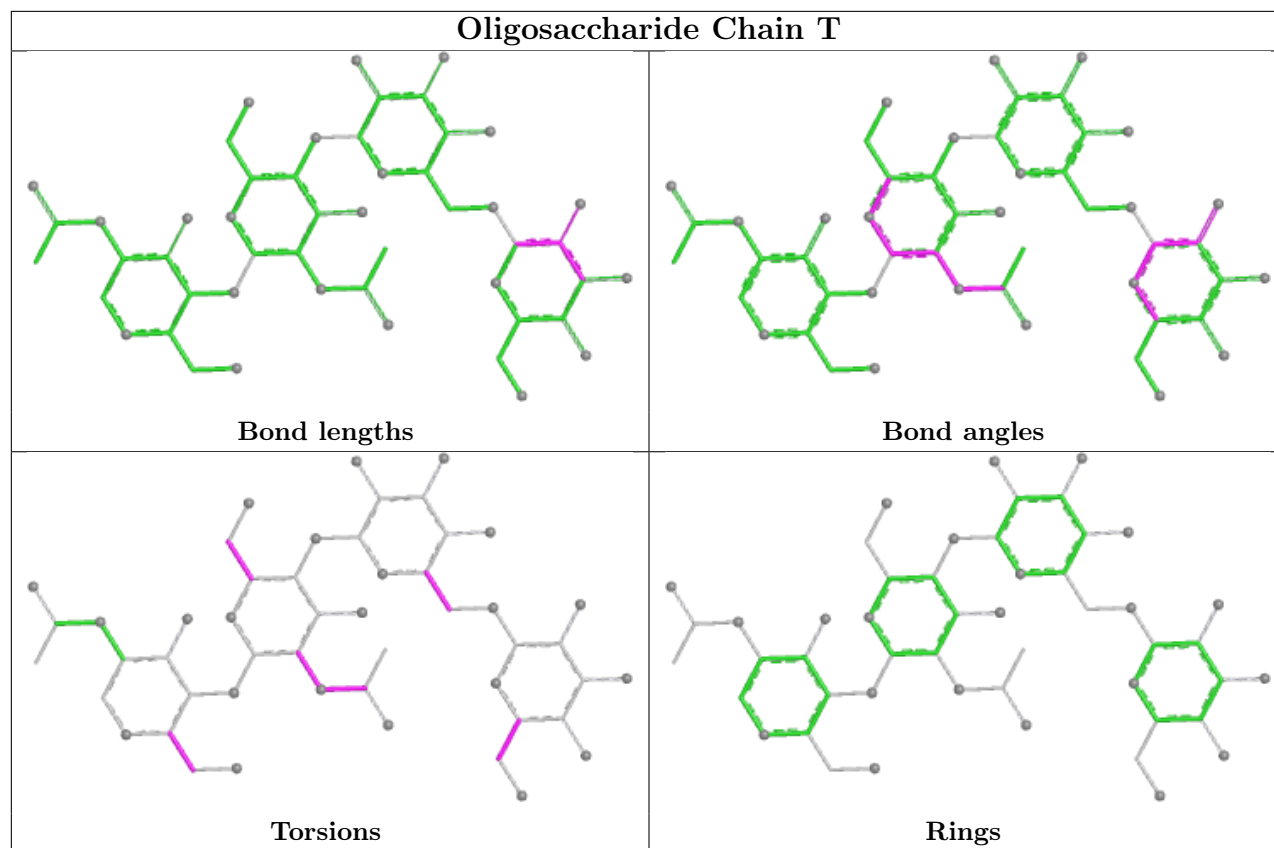

5.6 Ligand geometry [i](#)

4 ligands are modelled in this entry.

In the following table, the Counts columns list the number of bonds (or angles) for which Mogul statistics could be retrieved, the number of bonds (or angles) that are observed in the model and the number of bonds (or angles) that are defined in the Chemical Component Dictionary. The Link column lists molecule types, if any, to which the group is linked. The Z score for a bond length (or angle) is the number of standard deviations the observed value is removed from the expected value. A bond length (or angle) with $|Z| > 2$ is considered an outlier worth inspection. RMSZ is the root-mean-square of all Z scores of the bond lengths (or angles).

Mol	Type	Chain	Res	Link	Bond lengths			Bond angles		
					Counts	RMSZ	$\# Z > 2$	Counts	RMSZ	$\# Z > 2$
16	NAG	C	603	3	14,14,15	0.29	0	17,19,21	0.45	0
16	NAG	D	705	4	14,14,15	0.22	0	17,19,21	0.42	0
16	NAG	C	606	3	14,14,15	0.33	0	17,19,21	0.56	0
16	NAG	C	619	3	14,14,15	0.37	0	17,19,21	0.38	0

In the following table, the Chirals column lists the number of chiral outliers, the number of chiral centers analysed, the number of these observed in the model and the number defined in the Chemical Component Dictionary. Similar counts are reported in the Torsion and Rings columns. '-' means no outliers of that kind were identified.

Mol	Type	Chain	Res	Link	Chirals	Torsions	Rings
16	NAG	C	603	3	-	4/6/23/26	0/1/1/1
16	NAG	D	705	4	-	2/6/23/26	0/1/1/1
16	NAG	C	606	3	-	4/6/23/26	0/1/1/1
16	NAG	C	619	3	-	2/6/23/26	0/1/1/1

There are no bond length outliers.

There are no bond angle outliers.

There are no chirality outliers.

5 of 12 torsion outliers are listed below:

Mol	Chain	Res	Type	Atoms
16	D	705	NAG	O5-C5-C6-O6
16	C	619	NAG	C4-C5-C6-O6
16	C	619	NAG	O5-C5-C6-O6
16	D	705	NAG	C4-C5-C6-O6
16	C	603	NAG	C4-C5-C6-O6

There are no ring outliers.

1 monomer is involved in 1 short contact:

Mol	Chain	Res	Type	Clashes	Symm-Clashes
16	C	606	NAG	1	0

5.7 Other polymers [i](#)

There are no such residues in this entry.

5.8 Polymer linkage issues [i](#)

There are no chain breaks in this entry.

6 Fit of model and data [i](#)

6.1 Protein, DNA and RNA chains [i](#)

In the following table, the column labelled ‘#RSRZ > 2’ contains the number (and percentage) of RSRZ outliers, followed by percent RSRZ outliers for the chain as percentile scores relative to all X-ray entries and entries of similar resolution. The OWAB column contains the minimum, median, 95th percentile and maximum values of the occupancy-weighted average B-factor per residue. The column labelled ‘Q < 0.9’ lists the number of (and percentage) of residues with an average occupancy less than 0.9.

Mol	Chain	Analysed	<RSRZ>	#RSRZ>2	OWAB(Å ²)	Q<0.9
1	A	230/239 (96%)	-0.13	9 (3%) 43 42	294, 318, 478, 494	0
2	B	204/211 (96%)	-0.08	4 (1%) 65 56	282, 349, 452, 467	0
3	C	447/480 (93%)	0.00	22 (4%) 35 36	198, 274, 313, 343	0
4	D	130/140 (92%)	0.13	5 (3%) 44 42	196, 219, 291, 311	0
5	E	224/238 (94%)	-0.20	7 (3%) 51 46	215, 252, 299, 317	0
6	F	212/215 (98%)	-0.31	2 (0%) 81 70	204, 243, 286, 291	0
All	All	1447/1523 (95%)	-0.10	49 (3%) 48 44	196, 282, 457, 494	0

The worst 5 of 49 RSRZ outliers are listed below:

Mol	Chain	Res	Type	RSRZ
3	C	493	VAL	8.5
3	C	491	LEU	7.0
3	C	492	GLY	6.8
5	E	128	ILE	6.3
3	C	38	VAL	5.7

6.2 Non-standard residues in protein, DNA, RNA chains [i](#)

There are no non-standard protein/DNA/RNA residues in this entry.

6.3 Carbohydrates [i](#)

In the following table, the Atoms column lists the number of modelled atoms in the group and the number defined in the chemical component dictionary. The B-factors column lists the minimum, median, 95th percentile and maximum values of B factors of atoms in the group. The column labelled ‘Q < 0.9’ lists the number of atoms with occupancy less than 0.9.

Mol	Type	Chain	Res	Atoms	RSCC	RSR	B-factors(\AA^2)	Q<0.9
13	NAG	Q	2	14/15	-0.13	0.11	343,343,343,343	0
13	BMA	P	3	11/12	-0.05	0.11	271,271,271,271	0
13	BMA	Q	3	11/12	-0.02	0.08	363,363,363,363	0
13	BMA	R	3	11/12	0.06	0.09	334,334,334,334	0
13	NAG	R	1	14/15	0.09	0.12	315,315,315,315	0
15	BMA	T	3	11/12	0.28	0.10	227,227,227,227	0
7	NAG	I	2	14/15	0.40	0.07	275,275,275,275	0
10	MAN	M	7	11/12	0.41	0.10	298,298,298,298	0
7	NAG	G	2	14/15	0.43	0.12	325,325,325,325	0
10	MAN	M	6	11/12	0.48	0.07	323,323,323,323	0
7	NAG	H	1	14/15	0.48	0.11	318,318,318,318	0
11	MAN	N	5	11/12	0.55	0.10	314,314,314,314	0
12	BMA	O	3	11/12	0.57	0.10	354,354,354,354	0
14	MAN	S	6	11/12	0.59	0.14	257,257,257,257	0
8	MAN	K	5	11/12	0.61	0.10	293,293,293,293	0
12	MAN	O	5	11/12	0.61	0.09	369,369,369,369	0
7	NAG	H	2	14/15	0.61	0.16	329,329,329,329	0
9	MAN	L	5	11/12	0.62	0.10	294,294,294,294	0
9	NAG	L	1	14/15	0.64	0.08	297,297,297,297	0
13	NAG	P	2	14/15	0.65	0.08	270,270,270,270	0
9	MAN	L	10	11/12	0.70	0.13	301,301,301,301	0
10	NAG	M	1	14/15	0.70	0.10	296,296,296,296	0
13	NAG	R	2	14/15	0.70	0.10	324,324,324,324	0
13	NAG	Q	1	14/15	0.71	0.08	311,311,311,311	0
11	MAN	N	4	11/12	0.73	0.16	321,321,321,321	0
8	MAN	K	6	11/12	0.73	0.06	292,292,292,292	0
15	MAN	T	4	11/12	0.73	0.10	247,247,247,247	0
9	MAN	L	7	11/12	0.75	0.13	303,303,303,303	0
10	MAN	M	4	11/12	0.77	0.09	308,308,308,308	0
15	NAG	T	2	14/15	0.79	0.07	219,219,219,219	0
13	NAG	P	1	14/15	0.80	0.09	270,270,270,270	0
8	MAN	K	4	11/12	0.81	0.06	281,281,281,281	0
10	MAN	M	5	11/12	0.81	0.04	317,317,317,317	0
15	NAG	T	1	14/15	0.81	0.10	212,212,212,212	0
14	MAN	S	8	11/12	0.82	0.14	253,253,253,253	0
11	BMA	N	3	11/12	0.83	0.06	314,314,314,314	0
9	NAG	L	2	14/15	0.83	0.11	305,305,305,305	0
12	NAG	O	1	14/15	0.84	0.08	302,302,302,302	0
14	MAN	S	9	11/12	0.85	0.17	264,264,264,264	0
14	MAN	S	10	11/12	0.85	0.13	238,238,238,238	0
8	MAN	K	7	11/12	0.85	0.06	311,311,311,311	0
14	BMA	S	3	11/12	0.86	0.08	249,249,249,249	0
10	NAG	M	2	14/15	0.87	0.10	295,295,295,295	0

Continued on next page...

Continued from previous page...

Mol	Type	Chain	Res	Atoms	RSCC	RSR	B-factors(\AA^2)	Q<0.9
12	MAN	O	4	11/12	0.87	0.07	372,372,372,372	0
12	NAG	O	2	14/15	0.87	0.16	330,330,330,330	0
9	MAN	L	4	11/12	0.90	0.10	296,296,296,296	0
8	BMA	K	3	11/12	0.90	0.05	273,273,273,273	0
8	MAN	K	8	11/12	0.90	0.15	305,305,305,305	0
7	NAG	J	1	14/15	0.92	0.07	292,292,292,292	0
9	MAN	L	8	11/12	0.92	0.09	290,290,290,290	0
14	NAG	S	1	14/15	0.92	0.16	254,254,254,254	0
9	MAN	L	6	11/12	0.93	0.06	295,295,295,295	0
14	MAN	S	11	11/12	0.93	0.14	235,235,235,235	0
7	NAG	G	1	14/15	0.93	0.06	318,318,318,318	0
10	MAN	M	8	11/12	0.94	0.11	305,305,305,305	0
11	NAG	N	1	14/15	0.94	0.08	276,276,276,276	0
14	MAN	S	7	11/12	0.95	0.08	244,244,244,244	0
9	MAN	L	9	11/12	0.95	0.05	284,284,284,284	0
10	BMA	M	3	11/12	0.95	0.03	299,299,299,299	0
8	NAG	K	2	14/15	0.96	0.08	259,259,259,259	0
14	MAN	S	5	11/12	0.96	0.11	248,248,248,248	0
9	BMA	L	3	11/12	0.96	0.08	300,300,300,300	0
7	NAG	J	2	14/15	0.96	0.07	318,318,318,318	0
14	MAN	S	4	11/12	0.97	0.11	242,242,242,242	0
11	NAG	N	2	14/15	0.97	0.10	296,296,296,296	0
14	NAG	S	2	14/15	0.97	0.11	250,250,250,250	0
7	NAG	I	1	14/15	0.97	0.05	272,272,272,272	0
8	NAG	K	1	14/15	0.98	0.06	261,261,261,261	0

The following is a graphical depiction of the model fit to experimental electron density for oligosaccharide. Each fit is shown from different orientation to approximate a three-dimensional view.

Electron density around Chain G:

$2mF_o-DF_c$ (at 0.7 rmsd) in gray
 mF_o-DF_c (at 3 rmsd) in purple (negative)
and green (positive)

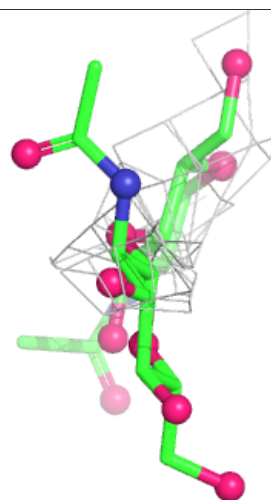
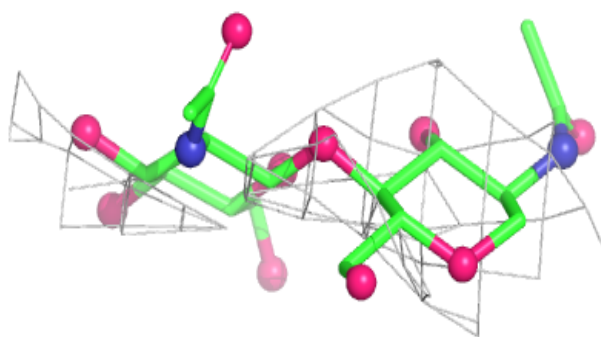
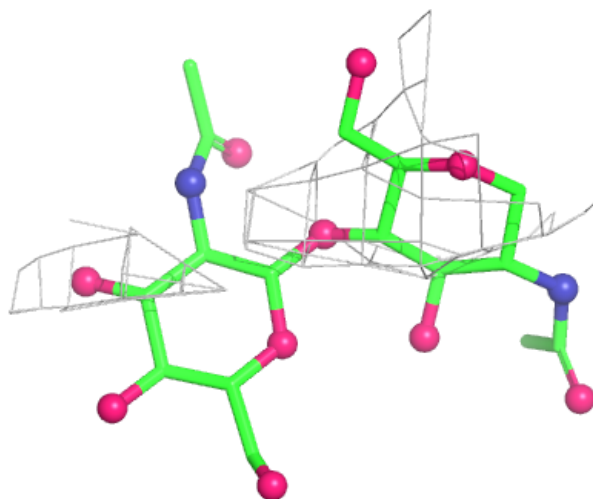

Electron density around Chain H:

$2mF_o-DF_c$ (at 0.7 rnsd) in gray
 mF_o-DF_c (at 3 rnsd) in purple (negative)
and green (positive)

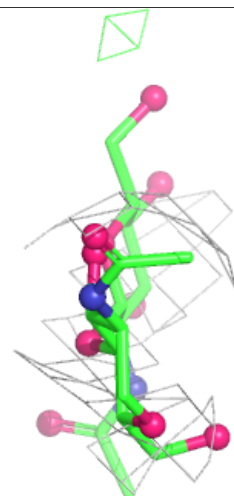
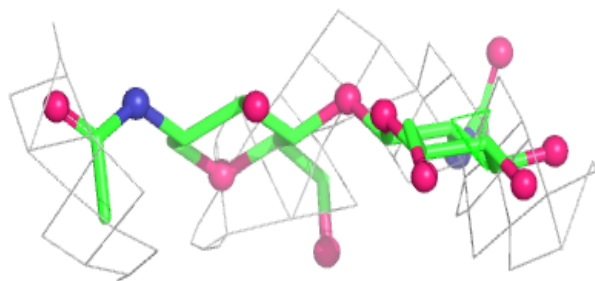
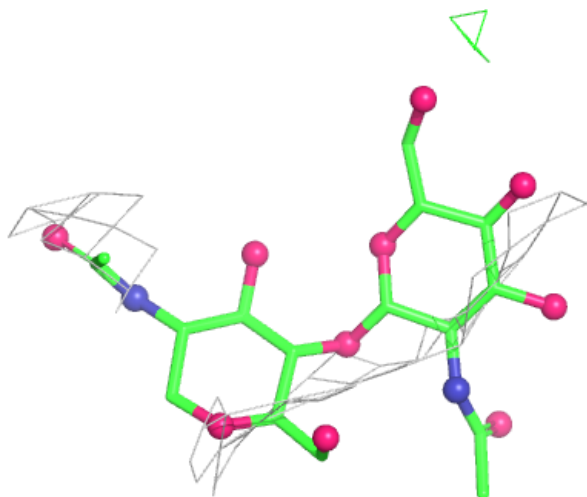

Electron density around Chain I:

$2mF_o-DF_c$ (at 0.7 rmsd) in gray
 mF_o-DF_c (at 3 rmsd) in purple (negative)
and green (positive)

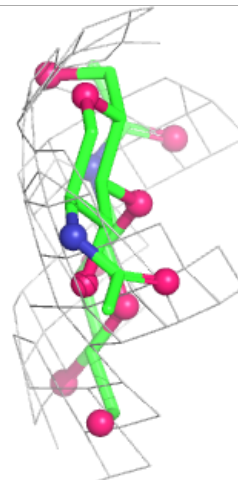
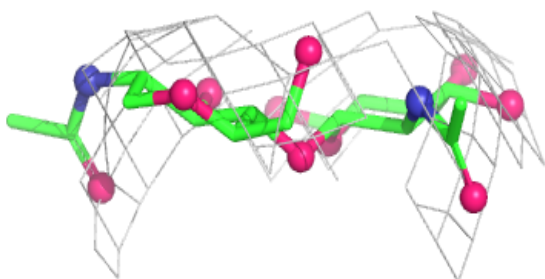
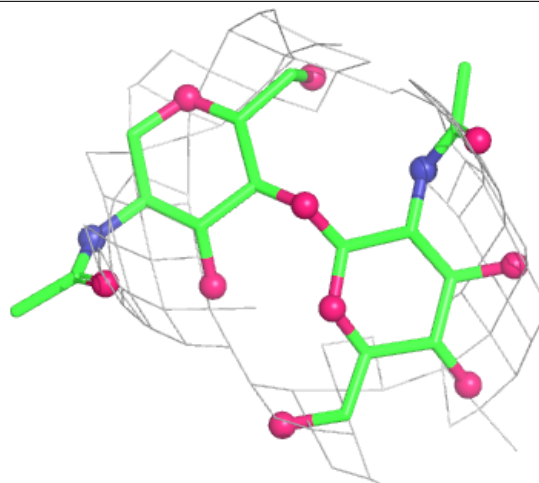

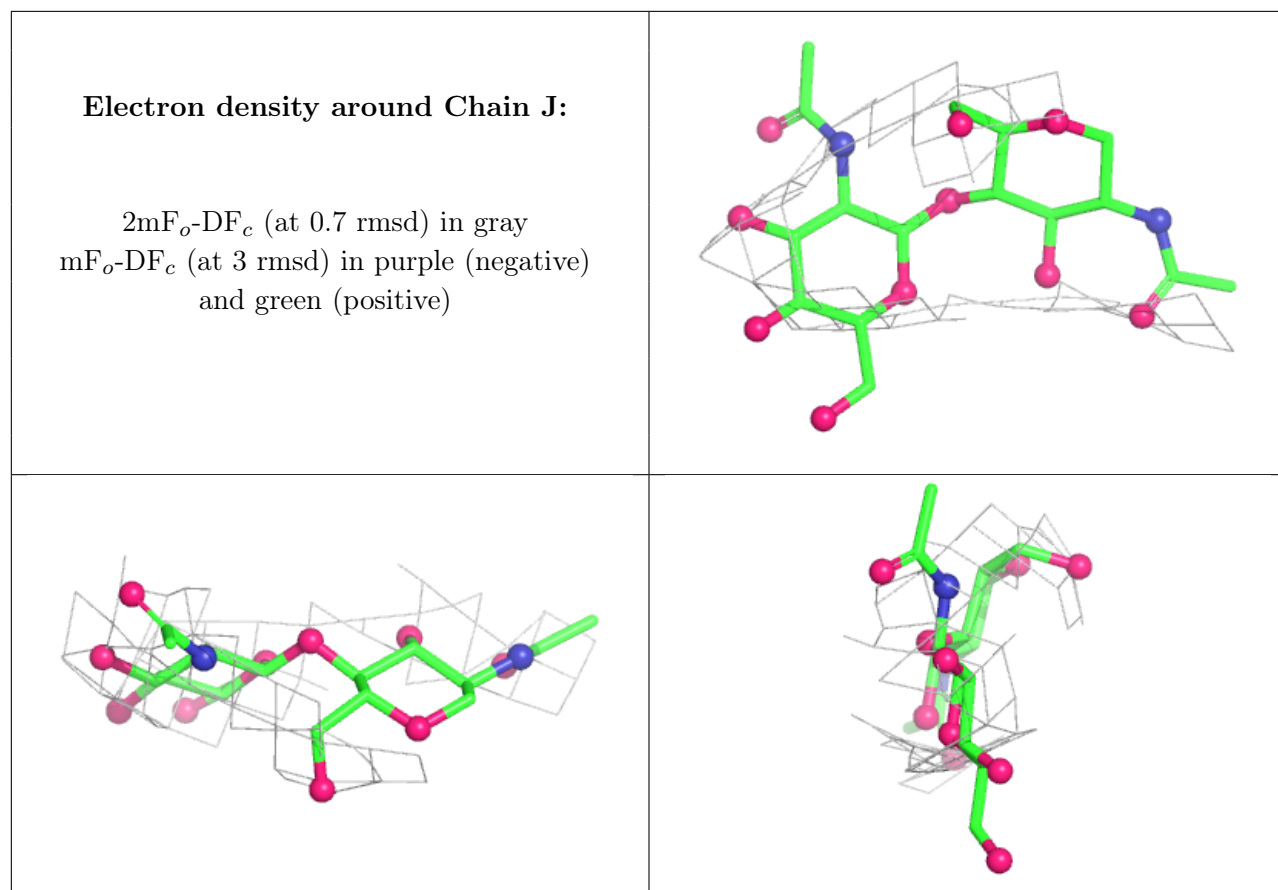

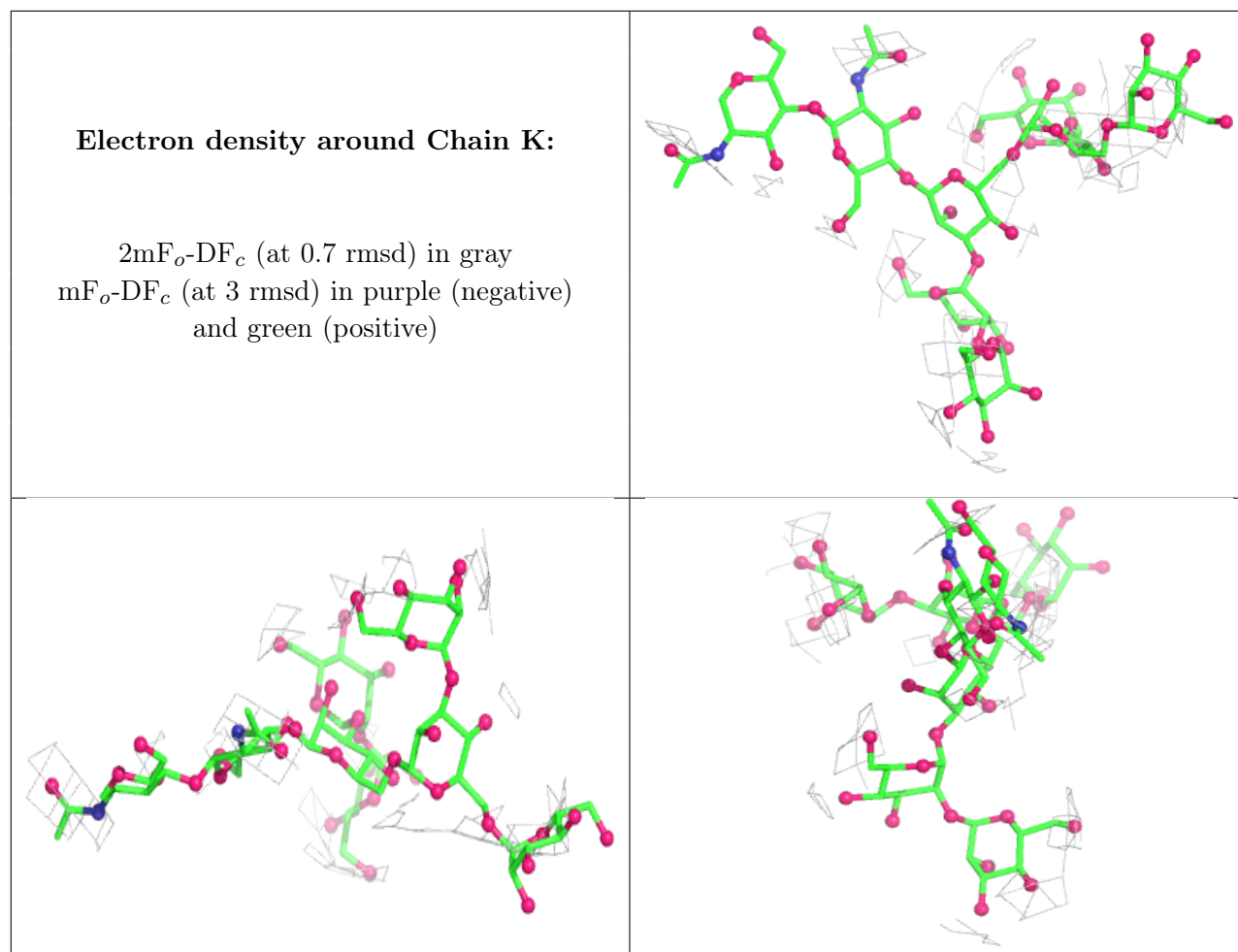

Electron density around Chain L:

$2mF_o-DF_c$ (at 0.7 rmsd) in gray
 mF_o-DF_c (at 3 rmsd) in purple (negative)
and green (positive)

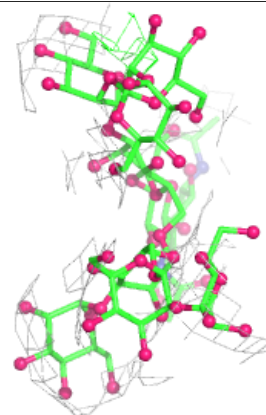
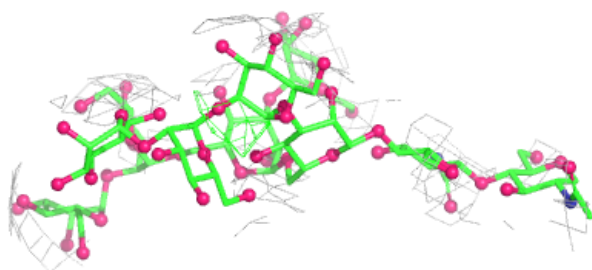
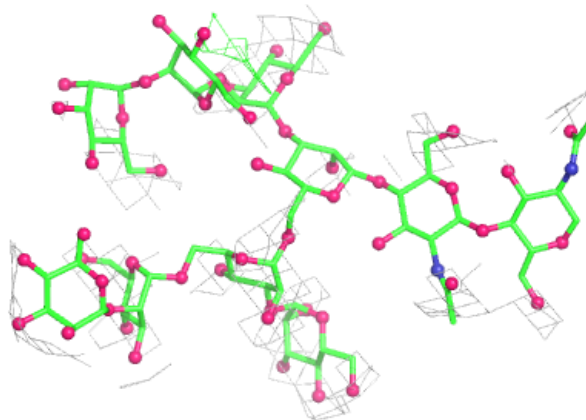

Electron density around Chain M:

$2mF_o-DF_c$ (at 0.7 rmsd) in gray
 mF_o-DF_c (at 3 rmsd) in purple (negative)
and green (positive)

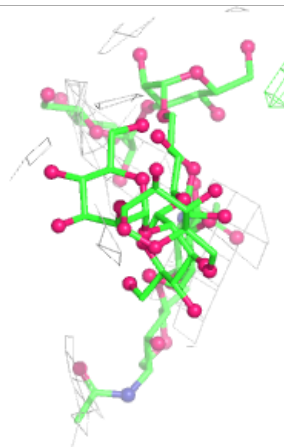
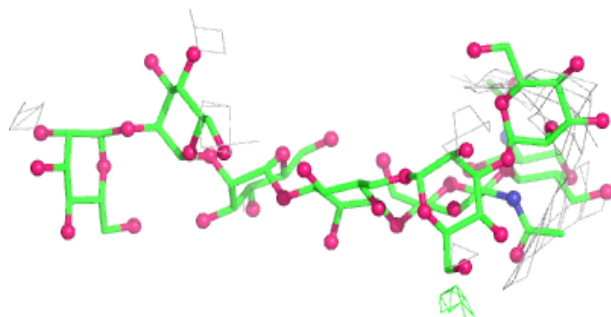
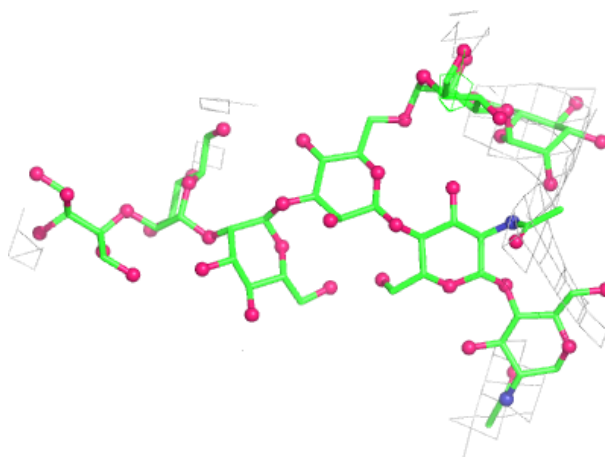

Electron density around Chain N:

$2mF_o-DF_c$ (at 0.7 rmsd) in gray
 mF_o-DF_c (at 3 rmsd) in purple (negative)
and green (positive)

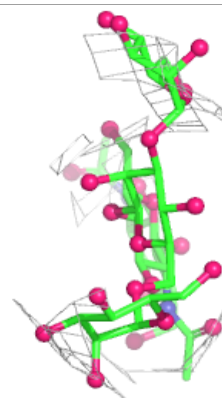
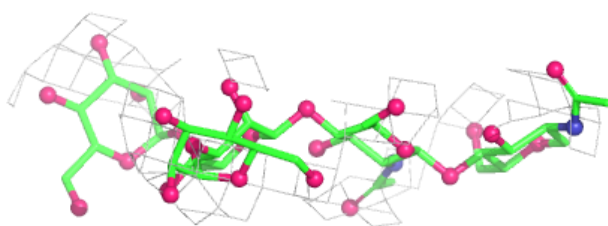
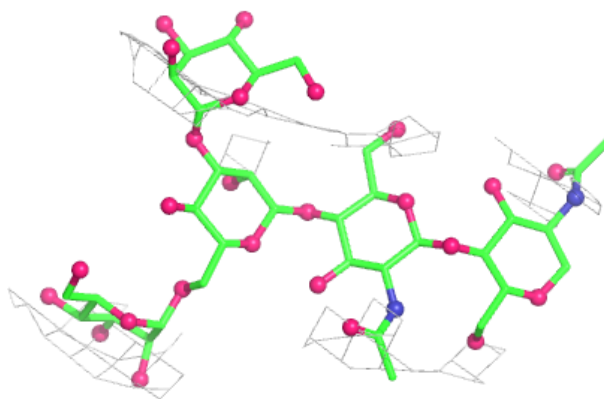
**Electron density around Chain O:**

$2mF_o-DF_c$ (at 0.7 rmsd) in gray
 mF_o-DF_c (at 3 rmsd) in purple (negative)
and green (positive)

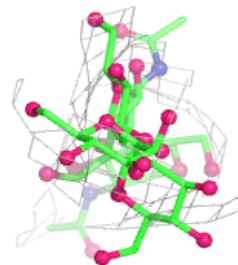
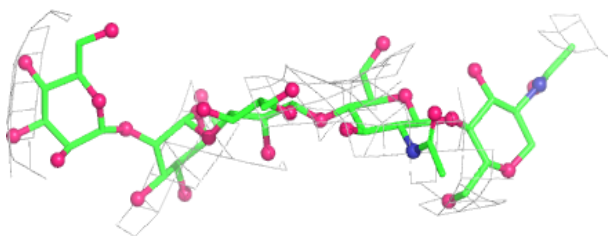
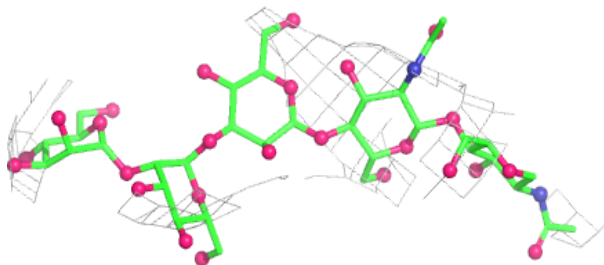

Electron density around Chain P:

$2mF_o-DF_c$ (at 0.7 rmsd) in gray
 mF_o-DF_c (at 3 rmsd) in purple (negative)
and green (positive)

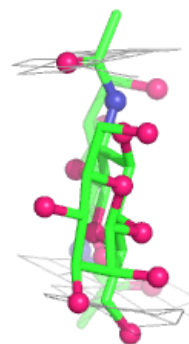
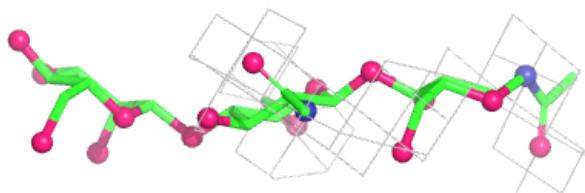
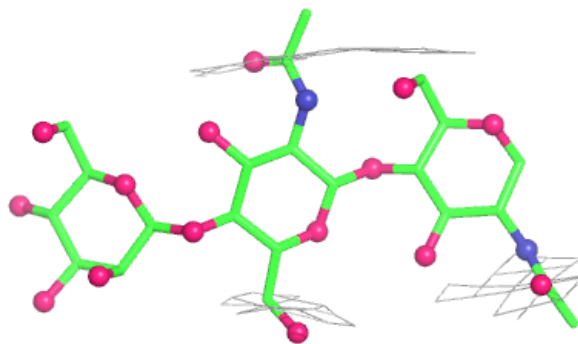
**Electron density around Chain Q:**

$2mF_o-DF_c$ (at 0.7 rmsd) in gray
 mF_o-DF_c (at 3 rmsd) in purple (negative)
and green (positive)

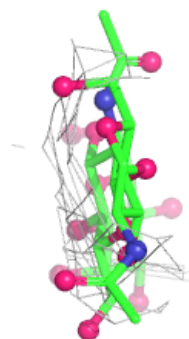
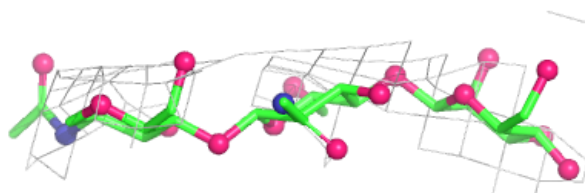
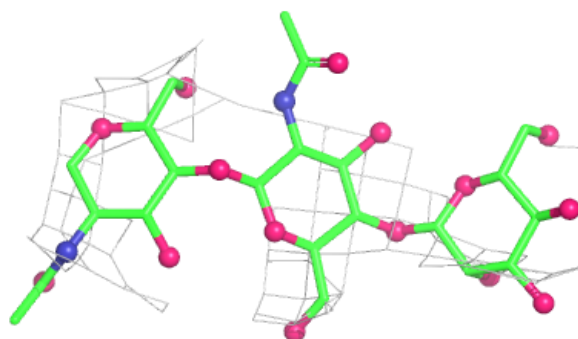

Electron density around Chain R:

$2mF_o-DF_c$ (at 0.7 rmsd) in gray
 mF_o-DF_c (at 3 rmsd) in purple (negative)
and green (positive)

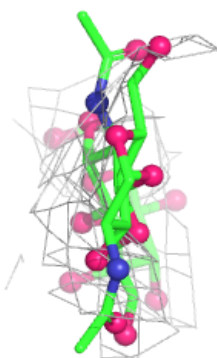
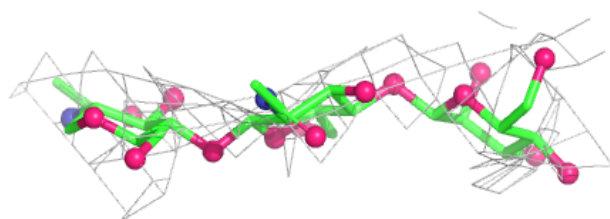
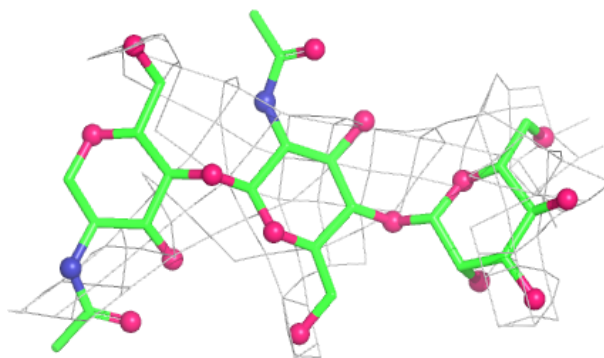
**Electron density around Chain S:**

$2mF_o-DF_c$ (at 0.7 rmsd) in gray
 mF_o-DF_c (at 3 rmsd) in purple (negative)
and green (positive)

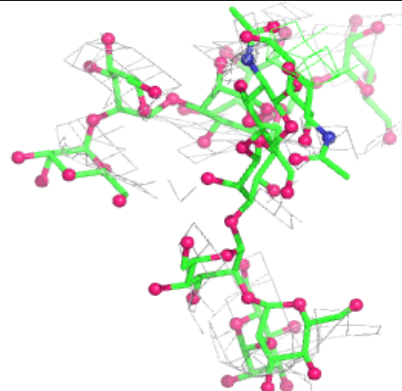
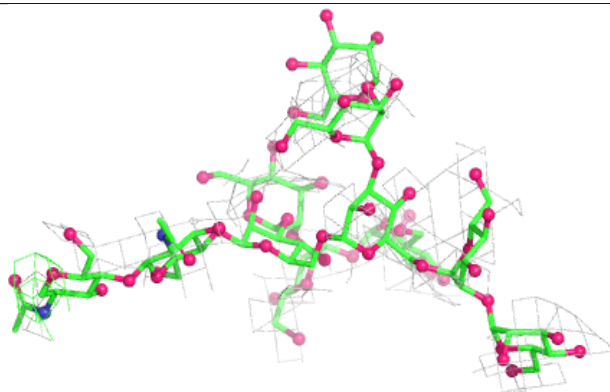
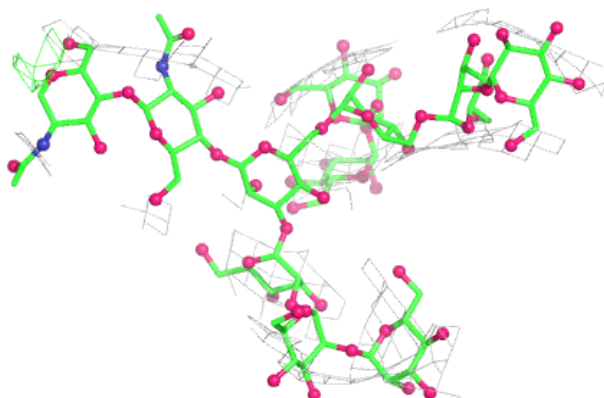

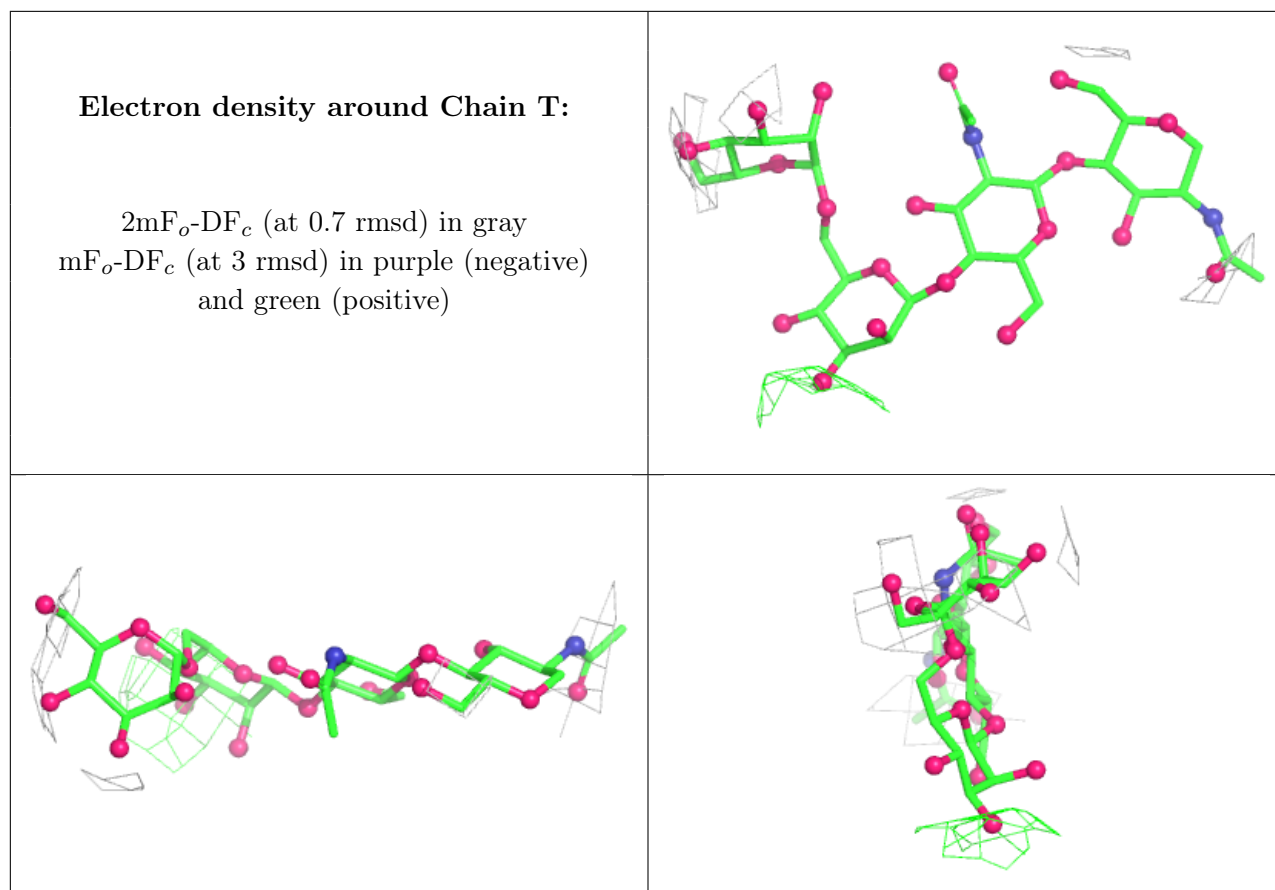

6.4 Ligands [i](#)

In the following table, the Atoms column lists the number of modelled atoms in the group and the number defined in the chemical component dictionary. The B-factors column lists the minimum, median, 95th percentile and maximum values of B factors of atoms in the group. The column labelled 'Q < 0.9' lists the number of atoms with occupancy less than 0.9.

Mol	Type	Chain	Res	Atoms	RSCC	RSR	B-factors(Å ²)	Q<0.9
16	NAG	C	603	14/15	-0.11	0.14	301,301,301,301	0
16	NAG	C	619	14/15	0.65	0.12	326,326,326,326	0
16	NAG	D	705	14/15	0.95	0.13	225,225,225,225	0
16	NAG	C	606	14/15	0.97	0.07	272,272,272,272	0

6.5 Other polymers [i](#)

There are no such residues in this entry.