



wwPDB EM Validation Summary Report ⓘ

Mar 7, 2026 – 03:48 AM UTC

PDB ID : 7LXT / pdb_00007lxt
EMDB ID : EMD-23574
Title : Structure of Plasmodium falciparum 20S proteasome with bound bortezomib
Authors : Morton, C.J.; Metcalfe, R.D.; Liu, B.; Xie, S.C.; Hanssen, E.; Leis, A.P.;
Tilley, L.; Griffin, M.D.W.
Deposited on : 2021-03-05
Resolution : 3.40 Å(reported)

This is a wwPDB EM Validation Summary Report for a publicly released PDB entry.

We welcome your comments at validation@mail.wwpdb.org

A user guide is available at

<https://www.wwpdb.org/validation/2017/EMValidationReportHelp>

with specific help available everywhere you see the ⓘ symbol.

The types of validation reports are described at

<http://www.wwpdb.org/validation/2017/FAQs#types>.

The following versions of software and data (see [references ⓘ](#)) were used in the production of this report:

EMDB validation analysis : 0.0.1.dev132
Mogul : 2022.3.0, CSD as543be (2022)
MolProbity : 4-5-2 with Phenix2.0
Buster-report : wwPDB partial adaption of 1.1.7 (2018)
Percentile statistics : 20250101.v01 (using entries in the PDB archive January 1st 2025)
EM percentile statistics : 202505.v01 (Using data in the EMDB archive up until May 2025)
MapQ : 1.9.13
Ideal geometry (proteins) : Engh & Huber (2001)
Ideal geometry (DNA, RNA) : Parkinson et al. (1996)
Validation Pipeline (wwPDB-VP) : 2.49

1 Overall quality at a glance i

The following experimental techniques were used to determine the structure:
ELECTRON MICROSCOPY

The reported resolution of this entry is 3.40 Å.

Percentile scores (ranging between 0-100) for global validation metrics of the entry are shown in the following graphic. The table shows the number of entries on which the scores are based.

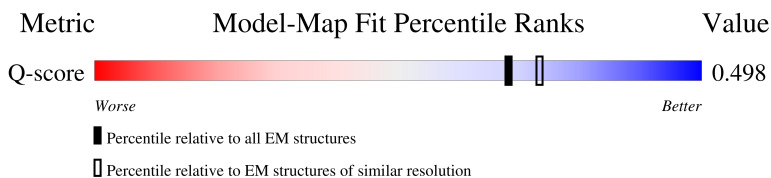
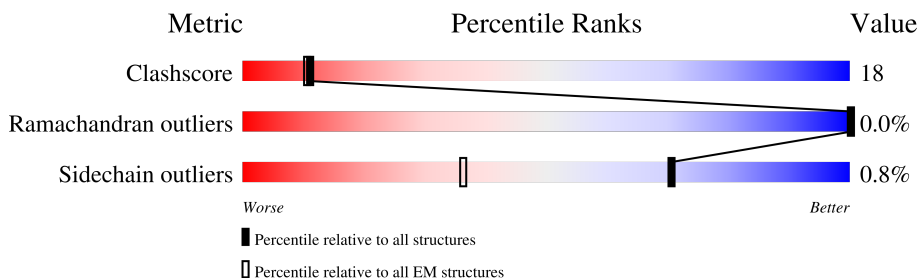

Metric	Whole archive (#Entries)	EM structures (#Entries)	Similar EM resolution (#Entries, resolution range(Å))
Clashscore	229148	23984	-
Ramachandran outliers	224038	23583	-
Sidechain outliers	223484	23102	-
Q-score	-	25397	14717 (2.90 - 3.90)

The table below summarises the geometric issues observed across the polymeric chains and their fit to the map. The red, orange, yellow and green segments of the bar indicate the fraction of residues that contain outliers for ≥ 3 , 2, 1 and 0 types of geometric quality criteria respectively. A grey segment represents the fraction of residues that are not modelled. The numeric value for each fraction is indicated below the corresponding segment, with a dot representing fractions $\leq 5\%$. The upper red bar (where present) indicates the fraction of residues that have poor fit to the EM map (all-atom inclusion $< 40\%$). The numeric value is given above the bar.

Mol	Chain	Length	Quality of chain
1	A	260	<div style="display: flex; align-items: center;"> <div style="width: 9%; height: 10px; background-color: red; margin-right: 5px;"></div> <div style="width: 63%; height: 10px; background-color: green; margin-right: 5px;"></div> <div style="width: 33%; height: 10px; background-color: yellow; margin-right: 5px;"></div> <div style="width: 5%; height: 10px; background-color: grey;"></div> </div> <p style="margin-left: 20px;">9% 63% 33% •</p>
1	O	260	<div style="display: flex; align-items: center;"> <div style="width: 10%; height: 10px; background-color: red; margin-right: 5px;"></div> <div style="width: 62%; height: 10px; background-color: green; margin-right: 5px;"></div> <div style="width: 34%; height: 10px; background-color: yellow; margin-right: 5px;"></div> <div style="width: 5%; height: 10px; background-color: grey;"></div> </div> <p style="margin-left: 20px;">10% 62% 34% •</p>
2	B	235	<div style="display: flex; align-items: center;"> <div style="width: 5%; height: 10px; background-color: red; margin-right: 5px;"></div> <div style="width: 65%; height: 10px; background-color: green; margin-right: 5px;"></div> <div style="width: 31%; height: 10px; background-color: yellow; margin-right: 5px;"></div> <div style="width: 5%; height: 10px; background-color: grey;"></div> </div> <p style="margin-left: 20px;">5% 65% 31% •</p>
2	P	235	<div style="display: flex; align-items: center;"> <div style="width: 5%; height: 10px; background-color: red; margin-right: 5px;"></div> <div style="width: 64%; height: 10px; background-color: green; margin-right: 5px;"></div> <div style="width: 32%; height: 10px; background-color: yellow; margin-right: 5px;"></div> <div style="width: 5%; height: 10px; background-color: grey;"></div> </div> <p style="margin-left: 20px;">5% 64% 32% •</p>

Continued on next page...

Continued from previous page...

Mol	Chain	Length	Quality of chain
3	C	246	6% 63% 34% ..
3	Q	246	5% 62% 35% ..
4	D	241	5% 65% 31% .
4	R	241	5% 63% 34% .
5	E	256	7% 56% 35% 9%
5	S	256	7% 57% 34% 9%
6	F	254	6% 60% 32% 7%
6	T	254	6% 60% 32% 7%
7	G	252	. 61% 34% 5%
7	U	252	. 60% 35% 5%
8	H	252	. 52% 35% 13%
8	V	252	. 52% 35% 13%
9	I	229	. 59% 36% 5%
9	W	229	. 59% 36% 5%
10	J	218	5% 57% 41% .
10	X	218	5% 57% 41% .
11	K	195	. 61% 38% .
11	Y	195	. 59% 39% .
12	L	211	. 63% 36% ..
12	Z	211	. 64% 35% ..
13	M	240	. 55% 33% 11%
13	a	240	. 55% 33% 11%
14	N	265	5% 55% 30% . 14%
14	b	265	. 54% 31% . 14%

2 Entry composition [i](#)

There are 15 unique types of molecules in this entry. The entry contains 50536 atoms, of which 0 are hydrogens and 0 are deuteriums.

In the tables below, the AltConf column contains the number of residues with at least one atom in alternate conformation and the Trace column contains the number of residues modelled with at most 2 atoms.

- Molecule 1 is a protein called 20S proteasome alpha-1 subunit.

Mol	Chain	Residues	Atoms					AltConf	Trace
			Total	C	N	O	S		
1	A	252	Total	C	N	O	S	0	0
			2001	1255	336	396	14		
1	O	252	Total	C	N	O	S	0	0
			2001	1255	336	396	14		

- Molecule 2 is a protein called 20S proteasome alpha-2 subunit.

Mol	Chain	Residues	Atoms					AltConf	Trace
			Total	C	N	O	S		
2	B	227	Total	C	N	O	S	0	0
			1805	1161	296	342	6		
2	P	227	Total	C	N	O	S	0	0
			1805	1161	296	342	6		

- Molecule 3 is a protein called 20S proteasome alpha-3 subunit.

Mol	Chain	Residues	Atoms					AltConf	Trace
			Total	C	N	O	S		
3	C	242	Total	C	N	O	S	0	0
			1934	1237	315	378	4		
3	Q	242	Total	C	N	O	S	0	0
			1934	1237	315	378	4		

- Molecule 4 is a protein called 20S proteasome alpha-4 subunit.

Mol	Chain	Residues	Atoms					AltConf	Trace
			Total	C	N	O	S		
4	D	233	Total	C	N	O	S	0	0
			1845	1178	312	347	8		
4	R	233	Total	C	N	O	S	0	0
			1845	1178	312	347	8		

- Molecule 5 is a protein called 20S proteasome alpha-5 subunit.

Mol	Chain	Residues	Atoms					AltConf	Trace
			Total	C	N	O	S		
5	E	233	1802	1136	298	357	11	0	0
5	S	233	1802	1136	298	357	11	0	0

- Molecule 6 is a protein called 20S proteasome alpha-6 subunit.

Mol	Chain	Residues	Atoms					AltConf	Trace
			Total	C	N	O	S		
6	F	235	1866	1187	308	360	11	0	0
6	T	235	1866	1187	308	360	11	0	0

- Molecule 7 is a protein called 20S proteasome alpha-7 subunit.

Mol	Chain	Residues	Atoms					AltConf	Trace
			Total	C	N	O	S		
7	G	240	1968	1251	330	374	13	0	0
7	U	240	1968	1251	330	374	13	0	0

- Molecule 8 is a protein called 20S proteasome beta-1 subunit.

Mol	Chain	Residues	Atoms					AltConf	Trace
			Total	C	N	O	S		
8	H	220	1772	1124	306	330	12	0	0
8	V	220	1772	1124	306	330	12	0	0

- Molecule 9 is a protein called 20S proteasome beta-2 subunit.

Mol	Chain	Residues	Atoms					AltConf	Trace
			Total	C	N	O	S		
9	I	218	1664	1049	290	311	14	0	0
9	W	218	1664	1049	290	311	14	0	0

- Molecule 10 is a protein called 20S proteasome beta-3 subunit.

Mol	Chain	Residues	Atoms					AltConf	Trace
			Total	C	N	O	S		
10	J	215	1698	1082	275	327	14	0	0

Continued on next page...

Continued from previous page...

Mol	Chain	Residues	Atoms					AltConf	Trace
10	X	215	Total	C	N	O	S	0	0
			1698	1082	275	327	14		

- Molecule 11 is a protein called 20S proteasome beta-4 subunit.

Mol	Chain	Residues	Atoms					AltConf	Trace
11	K	195	Total	C	N	O	S	0	0
			1614	1042	266	298	8		
11	Y	195	Total	C	N	O	S	0	0
			1614	1042	266	298	8		

- Molecule 12 is a protein called 20S proteasome beta-5 subunit.

Mol	Chain	Residues	Atoms					AltConf	Trace
12	L	209	Total	C	N	O	S	0	0
			1647	1050	273	317	7		
12	Z	209	Total	C	N	O	S	0	0
			1647	1050	273	317	7		

- Molecule 13 is a protein called 20S proteasome beta-6 subunit.

Mol	Chain	Residues	Atoms					AltConf	Trace
13	M	213	Total	C	N	O	S	0	0
			1696	1085	283	321	7		
13	a	213	Total	C	N	O	S	0	0
			1696	1085	283	321	7		

- Molecule 14 is a protein called 20S proteasome beta-7 subunit.

Mol	Chain	Residues	Atoms					AltConf	Trace
14	N	227	Total	C	N	O	S	0	0
			1872	1197	316	352	7		
14	b	227	Total	C	N	O	S	0	0
			1872	1197	316	352	7		

- Molecule 15 is N-[(1R)-1-(DIHYDROXYBORYL)-3-METHYLBUTYL]-N-(PYRAZIN-2-YLCARBONYL)-L-PHENYLALANINAMIDE (CCD ID: BO2) (formula: C₁₉H₂₅BN₄O₄) (labeled as "Ligand of Interest" by depositor).

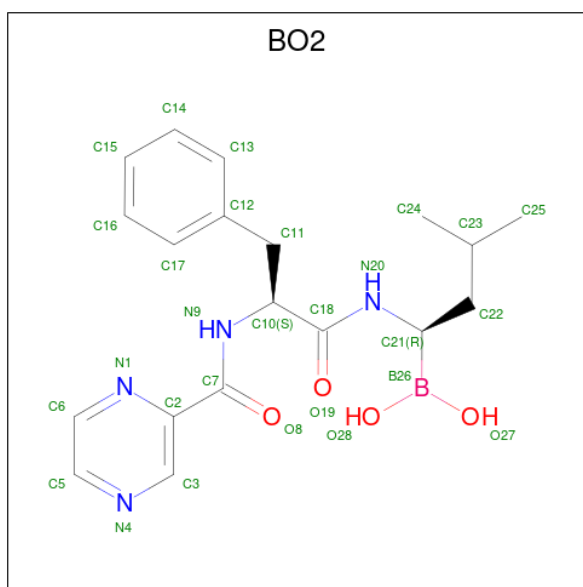

Mol	Chain	Residues	Atoms					AltConf
			Total	B	C	N	O	
15	H	1	Total 28	B 1	C 19	N 4	O 4	0
15	I	1	Total 28	B 1	C 19	N 4	O 4	0
15	L	1	Total 28	B 1	C 19	N 4	O 4	0
15	V	1	Total 28	B 1	C 19	N 4	O 4	0
15	W	1	Total 28	B 1	C 19	N 4	O 4	0
15	Z	1	Total 28	B 1	C 19	N 4	O 4	0

3 Residue-property plots

These plots are drawn for all protein, RNA, DNA and oligosaccharide chains in the entry. The first graphic for a chain summarises the proportions of the various outlier classes displayed in the second graphic. The second graphic shows the sequence view annotated by issues in geometry and atom inclusion in map density. Residues are color-coded according to the number of geometric quality criteria for which they contain at least one outlier: green = 0, yellow = 1, orange = 2 and red = 3 or more. A red diamond above a residue indicates a poor fit to the EM map for this residue (all-atom inclusion < 40%). Stretches of 2 or more consecutive residues without any outlier are shown as a green connector. Residues present in the sample, but not in the model, are shown in grey.

- Molecule 1: 20S proteasome alpha-1 subunit

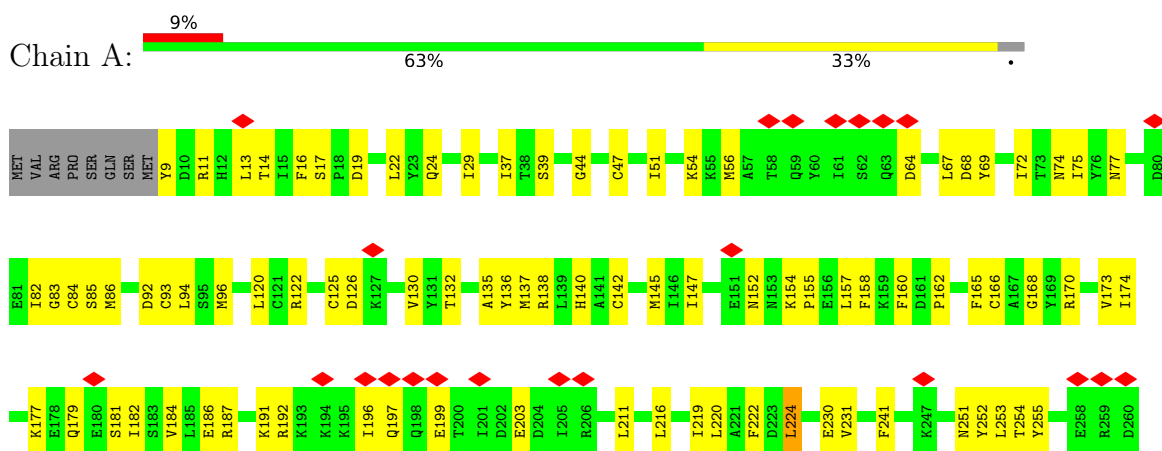

- Molecule 1: 20S proteasome alpha-1 subunit

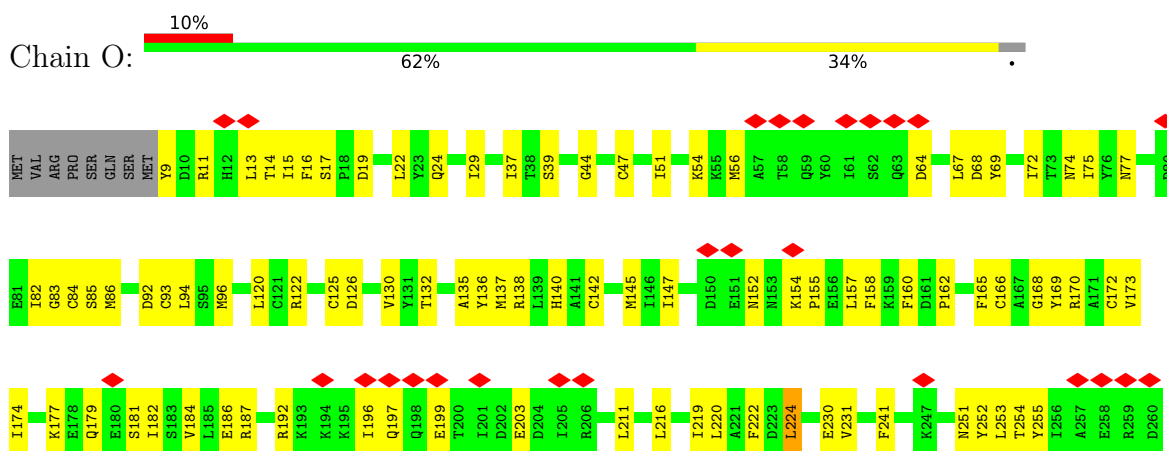

- Molecule 2: 20S proteasome alpha-2 subunit

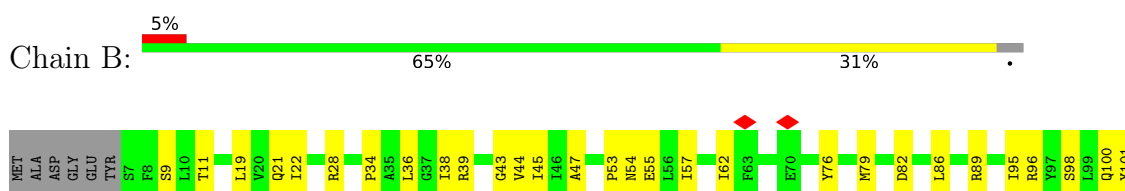

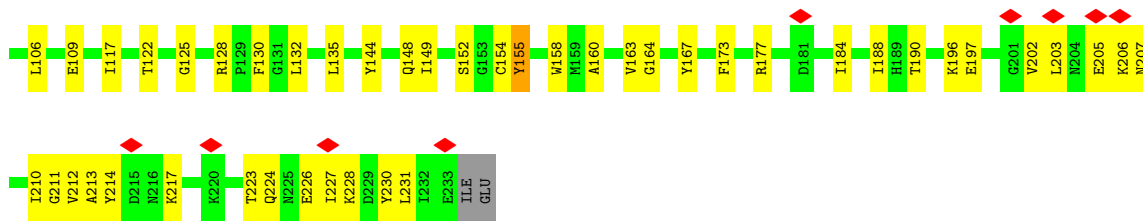

• Molecule 2: 20S proteasome alpha-2 subunit

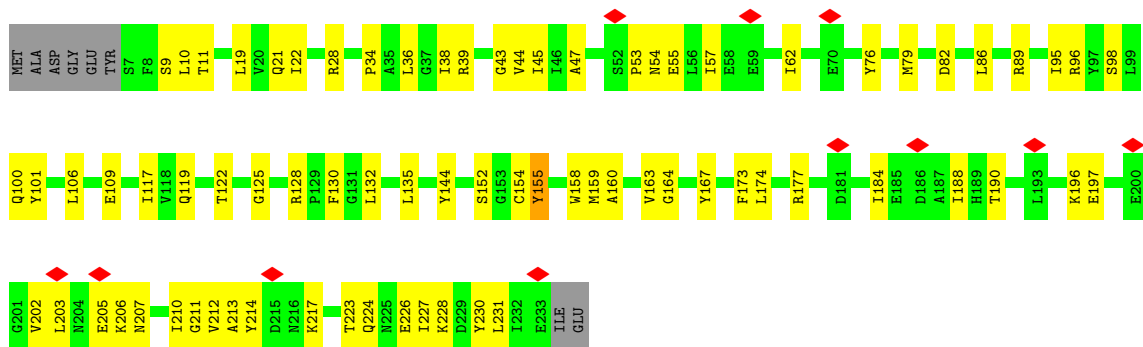

• Molecule 3: 20S proteasome alpha-3 subunit

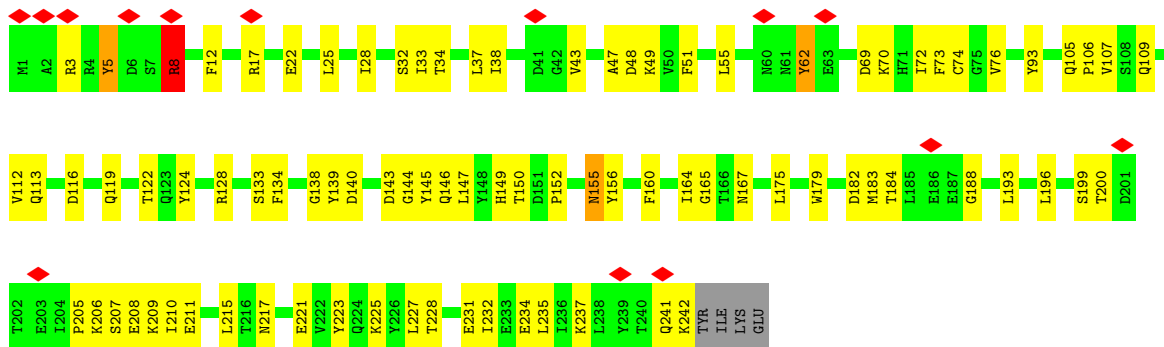

• Molecule 3: 20S proteasome alpha-3 subunit

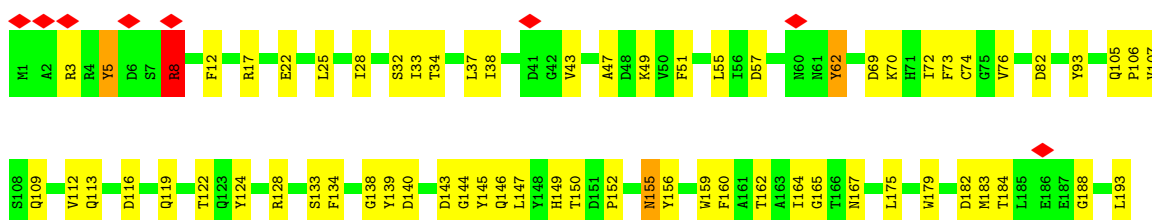

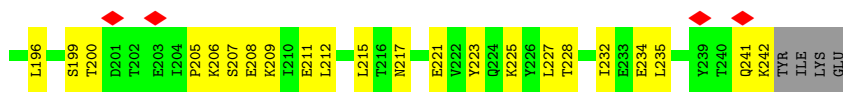

• Molecule 4: 20S proteasome alpha-4 subunit

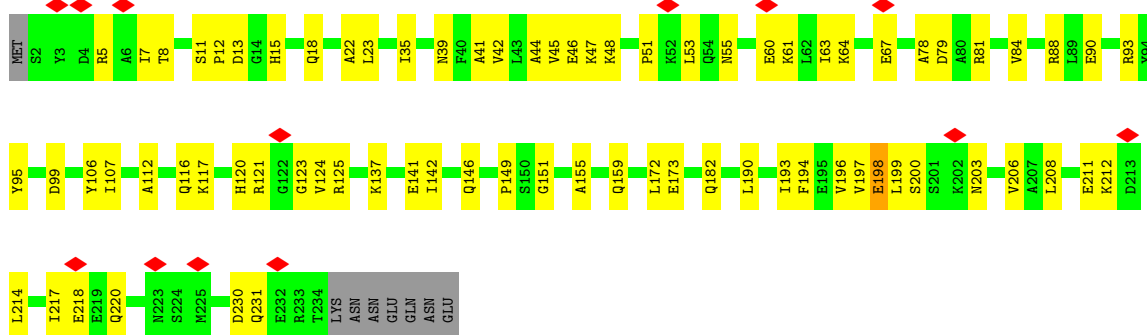

• Molecule 4: 20S proteasome alpha-4 subunit

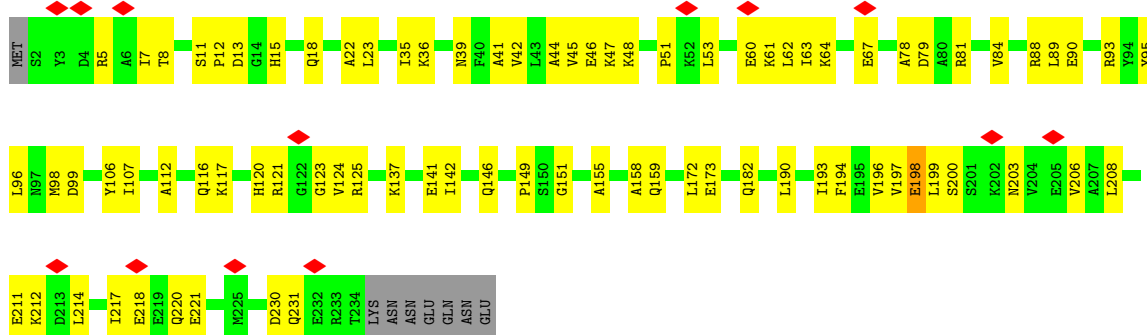

• Molecule 5: 20S proteasome alpha-5 subunit

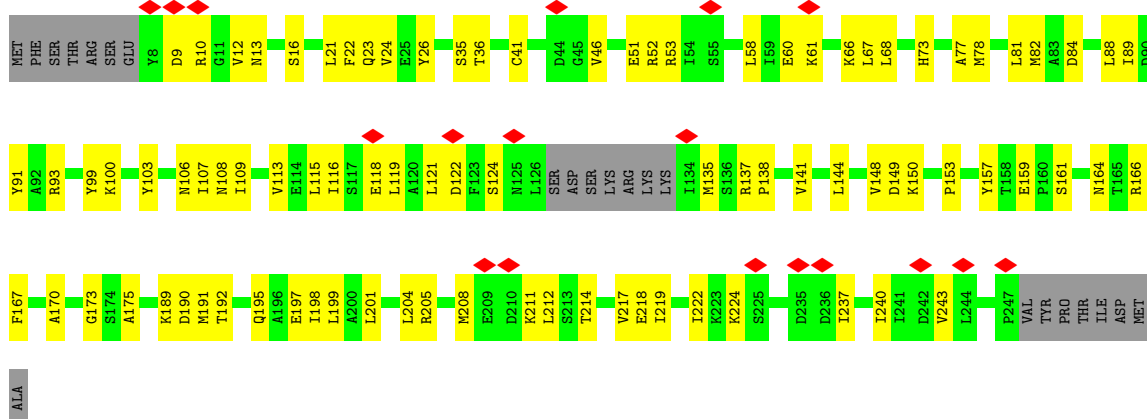

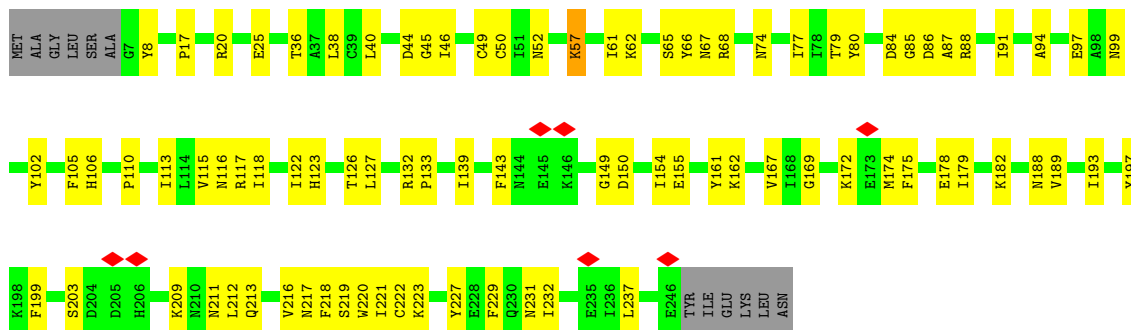

• Molecule 7: 20S proteasome alpha-7 subunit

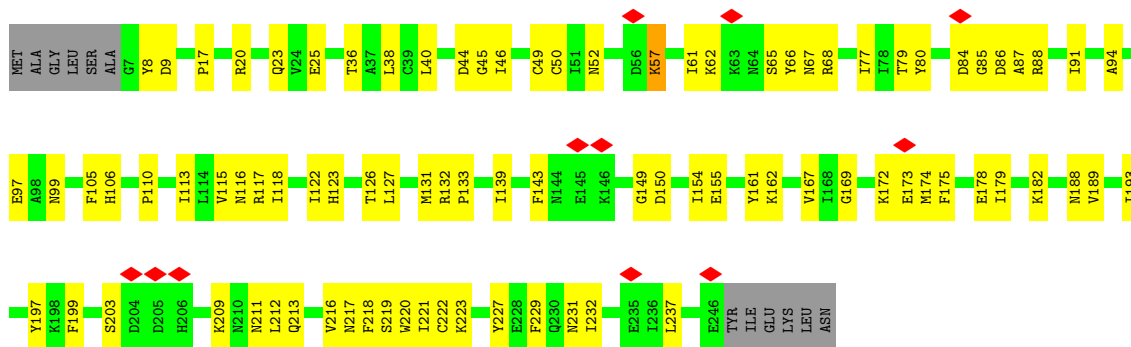

• Molecule 8: 20S proteasome beta-1 subunit

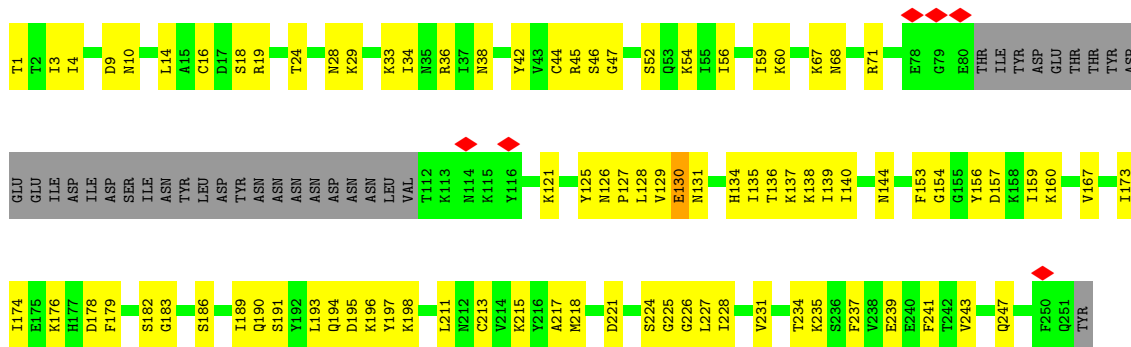

• Molecule 8: 20S proteasome beta-1 subunit

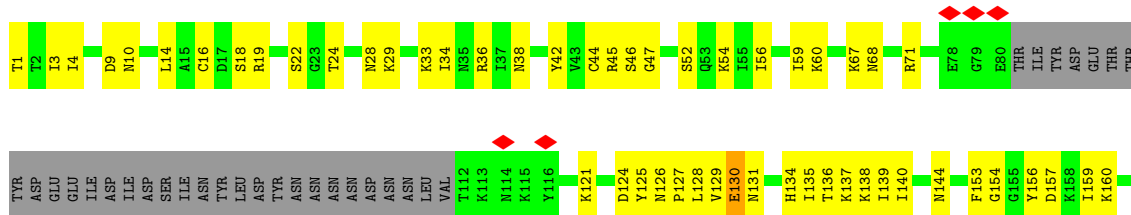



• Molecule 9: 20S proteasome beta-2 subunit

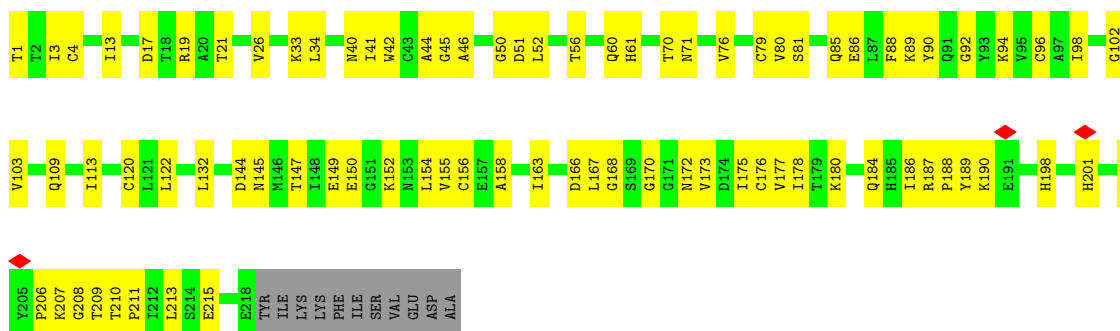

• Molecule 9: 20S proteasome beta-2 subunit

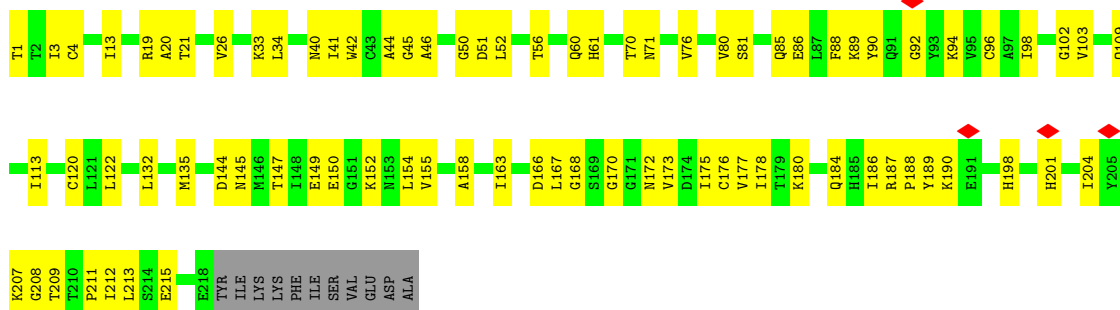

• Molecule 10: 20S proteasome beta-3 subunit

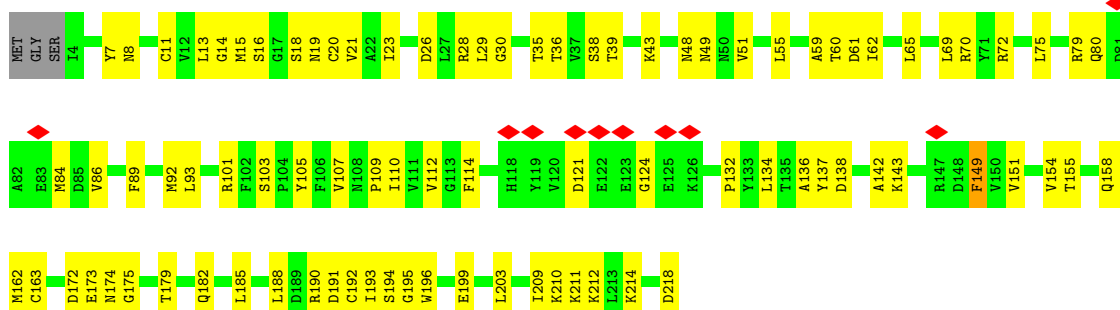

• Molecule 10: 20S proteasome beta-3 subunit



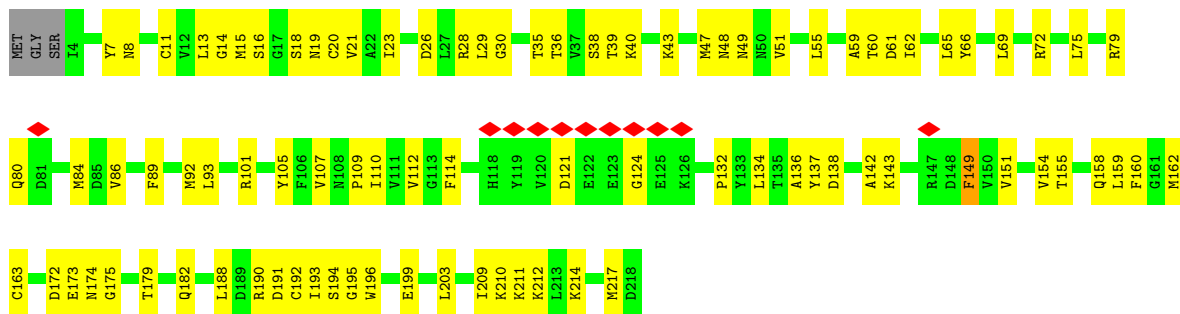

• Molecule 11: 20S proteasome beta-4 subunit

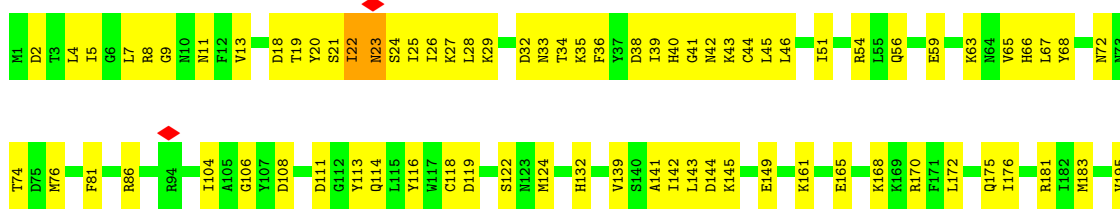

• Molecule 11: 20S proteasome beta-4 subunit

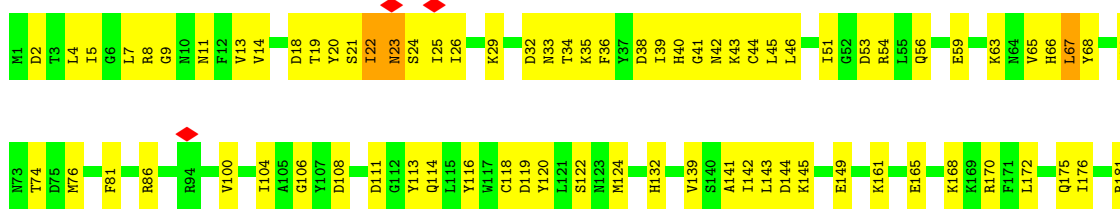

• Molecule 12: 20S proteasome beta-5 subunit

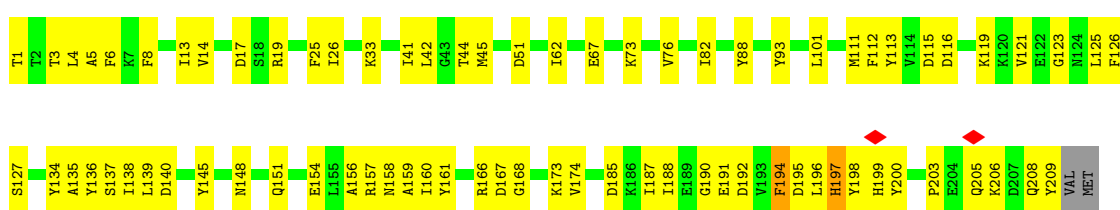

• Molecule 12: 20S proteasome beta-5 subunit



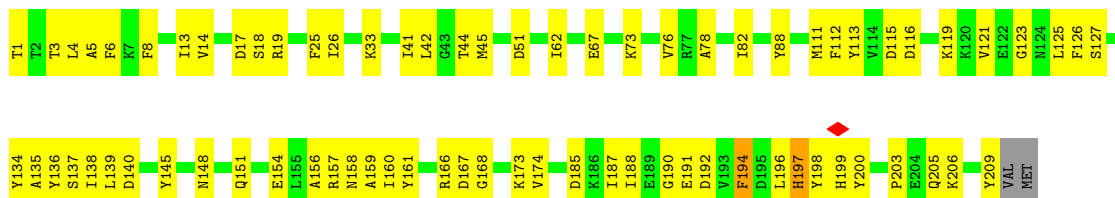

• Molecule 13: 20S proteasome beta-6 subunit

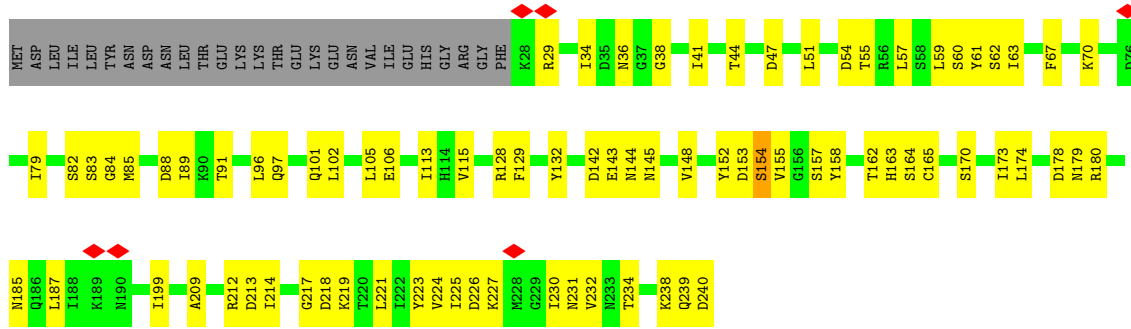

• Molecule 13: 20S proteasome beta-6 subunit

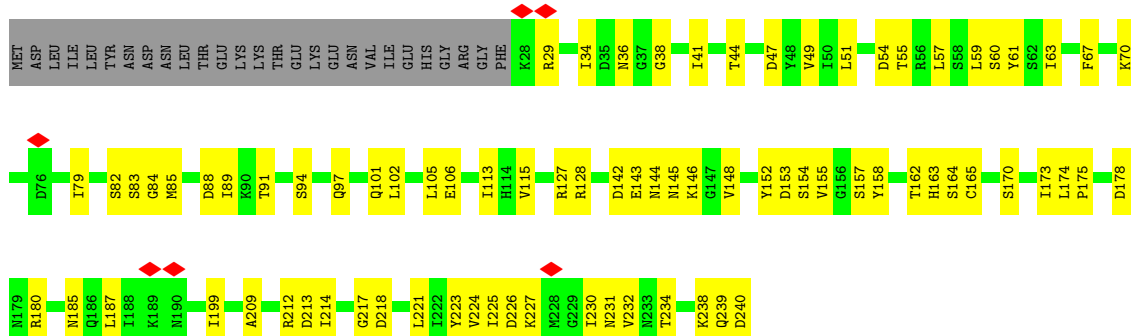

• Molecule 14: 20S proteasome beta-7 subunit

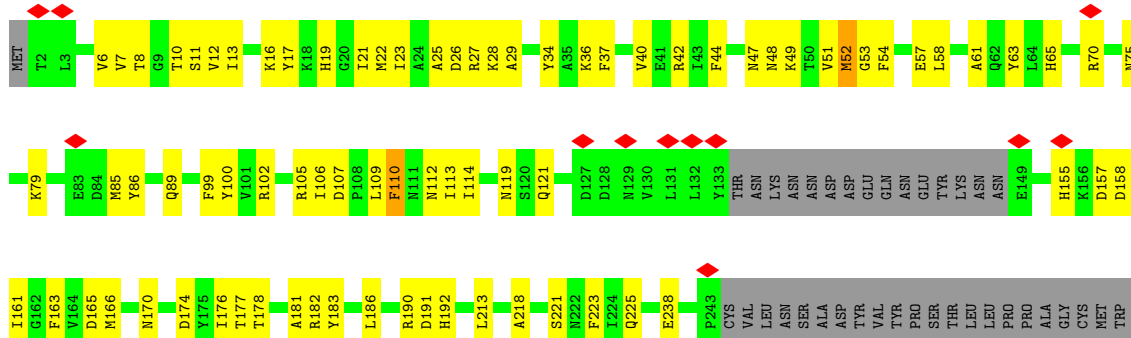

4 Experimental information

Property	Value	Source
EM reconstruction method	SINGLE PARTICLE	Depositor
Imposed symmetry	POINT, C2	Depositor
Number of particles used	24536	Depositor
Resolution determination method	FSC 0.143 CUT-OFF	Depositor
CTF correction method	PHASE FLIPPING AND AMPLITUDE CORRECTION	Depositor
Microscope	FEI TALOS ARCTICA	Depositor
Voltage (kV)	200	Depositor
Electron dose ($e^-/\text{\AA}^2$)	50	Depositor
Minimum defocus (nm)	Not provided	
Maximum defocus (nm)	Not provided	
Magnification	Not provided	
Image detector	GATAN K2 SUMMIT (4k x 4k)	Depositor
Maximum map value	29.773	Depositor
Minimum map value	-18.245	Depositor
Average map value	-0.000	Depositor
Map value standard deviation	1.000	Depositor
Recommended contour level	5	Depositor
Map size (Å)	450.63998, 450.63998, 450.63998	wwPDB
Map dimensions	344, 344, 344	wwPDB
Map angles (°)	90.0, 90.0, 90.0	wwPDB
Pixel spacing (Å)	1.31, 1.31, 1.31	Depositor

5 Model quality [i](#)

5.1 Standard geometry [i](#)

Bond lengths and bond angles in the following residue types are not validated in this section: BO2

The Z score for a bond length (or angle) is the number of standard deviations the observed value is removed from the expected value. A bond length (or angle) with $|Z| > 5$ is considered an outlier worth inspection. RMSZ is the root-mean-square of all Z scores of the bond lengths (or angles).

Mol	Chain	Bond lengths		Bond angles	
		RMSZ	# Z >5	RMSZ	# Z >5
1	A	0.31	0/2028	0.42	0/2734
1	O	0.31	0/2028	0.42	0/2734
2	B	0.31	0/1838	0.40	0/2482
2	P	0.31	0/1838	0.40	0/2482
3	C	0.36	0/1969	0.50	1/2665 (0.0%)
3	Q	0.36	0/1969	0.50	1/2665 (0.0%)
4	D	0.33	0/1875	0.46	0/2530
4	R	0.33	0/1875	0.46	0/2530
5	E	0.32	0/1827	0.44	0/2469
5	S	0.32	0/1827	0.44	0/2469
6	F	0.36	0/1900	0.46	0/2558
6	T	0.36	0/1900	0.46	0/2558
7	G	0.34	0/2011	0.43	0/2718
7	U	0.34	0/2011	0.43	0/2718
8	H	0.43	0/1802	0.52	0/2416
8	V	0.43	0/1802	0.52	0/2416
9	I	0.40	0/1699	0.51	0/2310
9	W	0.40	0/1699	0.51	0/2310
10	J	0.45	0/1727	0.51	0/2331
10	X	0.45	0/1727	0.51	0/2331
11	K	0.49	0/1649	0.51	0/2223
11	Y	0.49	0/1649	0.51	0/2223
12	L	0.44	0/1681	0.52	0/2266
12	Z	0.44	0/1681	0.52	0/2266
13	M	0.42	0/1728	0.49	0/2339
13	a	0.42	0/1728	0.49	0/2339
14	N	0.44	0/1911	0.50	0/2579
14	b	0.44	0/1911	0.50	0/2579
All	All	0.39	0/51290	0.48	2/69240 (0.0%)

Chiral center outliers are detected by calculating the chiral volume of a chiral center and verifying if

the center is modelled as a planar moiety or with the opposite hand. A planarity outlier is detected by checking planarity of atoms in a peptide group, atoms in a mainchain group or atoms of a sidechain that are expected to be planar.

Mol	Chain	#Chirality outliers	#Planarity outliers
11	K	0	1
11	Y	0	1
All	All	0	2

There are no bond length outliers.

All (2) bond angle outliers are listed below:

Mol	Chain	Res	Type	Atoms	Z	Observed(°)	Ideal(°)
3	C	8	ARG	CG-CD-NE	6.74	126.83	112.00
3	Q	8	ARG	CG-CD-NE	6.71	126.76	112.00

There are no chirality outliers.

All (2) planarity outliers are listed below:

Mol	Chain	Res	Type	Group
11	K	22	ILE	Peptide
11	Y	22	ILE	Peptide

5.2 Too-close contacts

In the following table, the Non-H and H(model) columns list the number of non-hydrogen atoms and hydrogen atoms in the chain respectively. The H(added) column lists the number of hydrogen atoms added and optimized by MolProbity. The Clashes column lists the number of clashes within the asymmetric unit, whereas Symm-Clashes lists symmetry-related clashes.

Mol	Chain	Non-H	H(model)	H(added)	Clashes	Symm-Clashes
1	A	2001	0	1993	73	0
1	O	2001	0	1993	75	0
2	B	1805	0	1829	64	0
2	P	1805	0	1829	67	0
3	C	1934	0	1935	71	0
3	Q	1934	0	1935	70	0
4	D	1845	0	1878	55	0
4	R	1845	0	1878	61	0
5	E	1802	0	1800	77	0
5	S	1802	0	1800	79	0
6	F	1866	0	1869	72	0

Continued on next page...

Continued from previous page...

Mol	Chain	Non-H	H(model)	H(added)	Clashes	Symm-Clashes
6	T	1866	0	1869	76	0
7	G	1968	0	1913	72	0
7	U	1968	0	1913	73	0
8	H	1772	0	1775	87	0
8	V	1772	0	1775	88	0
9	I	1664	0	1664	71	0
9	W	1664	0	1664	71	0
10	J	1698	0	1685	91	0
10	X	1698	0	1685	83	0
11	K	1614	0	1584	77	0
11	Y	1614	0	1584	80	0
12	L	1647	0	1599	76	0
12	Z	1647	0	1599	78	0
13	M	1696	0	1707	66	0
13	a	1696	0	1707	65	0
14	N	1872	0	1841	73	0
14	b	1872	0	1841	71	0
15	H	28	0	25	4	0
15	I	28	0	25	2	0
15	L	28	0	25	2	0
15	V	28	0	25	4	0
15	W	28	0	25	3	0
15	Z	28	0	25	4	0
All	All	50536	0	50294	1832	0

The all-atom clashscore is defined as the number of clashes found per 1000 atoms (including hydrogen atoms). The all-atom clashscore for this structure is 18.

The worst 5 of 1832 close contacts within the same asymmetric unit are listed below, sorted by their clash magnitude.

Atom-1	Atom-2	Interatomic distance (Å)	Clash overlap (Å)
3:Q:183:MET:HE2	3:Q:188:GLY:HA2	1.45	0.98
7:U:106:HIS:HB2	8:V:137:LYS:HG2	1.46	0.98
3:C:183:MET:HE2	3:C:188:GLY:HA2	1.45	0.95
11:K:172:LEU:HD11	11:Y:22:ILE:HG23	1.46	0.95
3:Q:8:ARG:HB2	3:Q:8:ARG:HH11	1.32	0.94

There are no symmetry-related clashes.

5.3 Torsion angles

5.3.1 Protein backbone

In the following table, the Percentiles column shows the percent Ramachandran outliers of the chain as a percentile score with respect to all PDB entries followed by that with respect to all EM entries.

The Analysed column shows the number of residues for which the backbone conformation was analysed, and the total number of residues.

Mol	Chain	Analysed	Favoured	Allowed	Outliers	Percentiles	
1	A	250/260 (96%)	229 (92%)	21 (8%)	0	100	100
1	O	250/260 (96%)	229 (92%)	21 (8%)	0	100	100
2	B	225/235 (96%)	209 (93%)	16 (7%)	0	100	100
2	P	225/235 (96%)	209 (93%)	16 (7%)	0	100	100
3	C	240/246 (98%)	224 (93%)	16 (7%)	0	100	100
3	Q	240/246 (98%)	224 (93%)	16 (7%)	0	100	100
4	D	231/241 (96%)	205 (89%)	26 (11%)	0	100	100
4	R	231/241 (96%)	205 (89%)	26 (11%)	0	100	100
5	E	229/256 (90%)	205 (90%)	24 (10%)	0	100	100
5	S	229/256 (90%)	205 (90%)	24 (10%)	0	100	100
6	F	233/254 (92%)	206 (88%)	27 (12%)	0	100	100
6	T	233/254 (92%)	206 (88%)	27 (12%)	0	100	100
7	G	238/252 (94%)	215 (90%)	23 (10%)	0	100	100
7	U	238/252 (94%)	214 (90%)	24 (10%)	0	100	100
8	H	216/252 (86%)	190 (88%)	26 (12%)	0	100	100
8	V	216/252 (86%)	191 (88%)	25 (12%)	0	100	100
9	I	216/229 (94%)	189 (88%)	27 (12%)	0	100	100
9	W	216/229 (94%)	189 (88%)	27 (12%)	0	100	100
10	J	213/218 (98%)	186 (87%)	27 (13%)	0	100	100
10	X	213/218 (98%)	186 (87%)	27 (13%)	0	100	100
11	K	193/195 (99%)	173 (90%)	20 (10%)	0	100	100
11	Y	193/195 (99%)	173 (90%)	20 (10%)	0	100	100
12	L	207/211 (98%)	171 (83%)	36 (17%)	0	100	100
12	Z	207/211 (98%)	171 (83%)	36 (17%)	0	100	100
13	M	211/240 (88%)	192 (91%)	18 (8%)	1 (0%)	24	54

Continued on next page...

Continued from previous page...

Mol	Chain	Analysed	Favoured	Allowed	Outliers	Percentiles	
13	a	211/240 (88%)	192 (91%)	18 (8%)	1 (0%)	24	54
14	N	223/265 (84%)	196 (88%)	27 (12%)	0	100	100
14	b	223/265 (84%)	195 (87%)	28 (13%)	0	100	100
All	All	6250/6708 (93%)	5579 (89%)	669 (11%)	2 (0%)	100	100

All (2) Ramachandran outliers are listed below:

Mol	Chain	Res	Type
13	M	154	SER
13	a	154	SER

5.3.2 Protein sidechains [i](#)

In the following table, the Percentiles column shows the percent sidechain outliers of the chain as a percentile score with respect to all PDB entries followed by that with respect to all EM entries.

The Analysed column shows the number of residues for which the sidechain conformation was analysed, and the total number of residues.

Mol	Chain	Analysed	Rotameric	Outliers	Percentiles	
1	A	223/231 (96%)	221 (99%)	2 (1%)	70	76
1	O	223/231 (96%)	221 (99%)	2 (1%)	70	76
2	B	199/205 (97%)	198 (100%)	1 (0%)	81	81
2	P	199/205 (97%)	198 (100%)	1 (0%)	81	81
3	C	209/213 (98%)	205 (98%)	4 (2%)	50	66
3	Q	209/213 (98%)	205 (98%)	4 (2%)	50	66
4	D	199/207 (96%)	197 (99%)	2 (1%)	68	75
4	R	199/207 (96%)	197 (99%)	2 (1%)	68	75
5	E	201/223 (90%)	201 (100%)	0	100	100
5	S	201/223 (90%)	201 (100%)	0	100	100
6	F	210/227 (92%)	209 (100%)	1 (0%)	81	81
6	T	210/227 (92%)	209 (100%)	1 (0%)	81	81
7	G	220/229 (96%)	219 (100%)	1 (0%)	81	81
7	U	220/229 (96%)	219 (100%)	1 (0%)	81	81
8	H	199/231 (86%)	197 (99%)	2 (1%)	68	75

Continued on next page...

Continued from previous page...

Mol	Chain	Analysed	Rotameric	Outliers	Percentiles	
8	V	199/231 (86%)	197 (99%)	2 (1%)	68	75
9	I	184/194 (95%)	183 (100%)	1 (0%)	81	81
9	W	184/194 (95%)	183 (100%)	1 (0%)	81	81
10	J	189/191 (99%)	188 (100%)	1 (0%)	81	81
10	X	189/191 (99%)	188 (100%)	1 (0%)	81	81
11	K	174/174 (100%)	171 (98%)	3 (2%)	53	67
11	Y	174/174 (100%)	171 (98%)	3 (2%)	53	67
12	L	174/176 (99%)	172 (99%)	2 (1%)	65	74
12	Z	174/176 (99%)	172 (99%)	2 (1%)	65	74
13	M	191/216 (88%)	191 (100%)	0	100	100
13	a	191/216 (88%)	191 (100%)	0	100	100
14	N	204/239 (85%)	202 (99%)	2 (1%)	68	75
14	b	204/239 (85%)	202 (99%)	2 (1%)	68	75
All	All	5552/5912 (94%)	5508 (99%)	44 (1%)	70	77

5 of 44 residues with a non-rotameric sidechain are listed below:

Mol	Chain	Res	Type
3	Q	155	ASN
9	W	149	GLU
4	R	107	ILE
7	U	57	LYS
11	Y	23	ASN

Sometimes sidechains can be flipped to improve hydrogen bonding and reduce clashes. 5 of 40 such sidechains are listed below:

Mol	Chain	Res	Type
7	U	74	ASN
11	Y	23	ASN
7	U	217	ASN
9	W	106	ASN
12	Z	85	ASN

5.3.3 RNA [i](#)

There are no RNA molecules in this entry.

5.4 Non-standard residues in protein, DNA, RNA chains [i](#)

There are no non-standard protein/DNA/RNA residues in this entry.

5.5 Carbohydrates [i](#)

There are no oligosaccharides in this entry.

5.6 Ligand geometry [i](#)

6 ligands are modelled in this entry.

In the following table, the Counts columns list the number of bonds (or angles) for which Mogul statistics could be retrieved, the number of bonds (or angles) that are observed in the model and the number of bonds (or angles) that are defined in the Chemical Component Dictionary. The Link column lists molecule types, if any, to which the group is linked. The Z score for a bond length (or angle) is the number of standard deviations the observed value is removed from the expected value. A bond length (or angle) with $|Z| > 2$ is considered an outlier worth inspection. RMSZ is the root-mean-square of all Z scores of the bond lengths (or angles).

Mol	Type	Chain	Res	Link	Bond lengths			Bond angles		
					Counts	RMSZ	# Z > 2	Counts	RMSZ	# Z > 2
15	BO2	L	301	12	25,29,29	1.61	4 (16%)	33,38,38	1.28	3 (9%)
15	BO2	I	301	9	25,29,29	1.63	4 (16%)	33,38,38	1.63	3 (9%)
15	BO2	H	301	8	25,29,29	1.60	4 (16%)	33,38,38	1.55	3 (9%)
15	BO2	Z	301	12	25,29,29	1.62	4 (16%)	33,38,38	1.29	3 (9%)
15	BO2	V	301	8	25,29,29	1.60	4 (16%)	33,38,38	1.55	3 (9%)
15	BO2	W	301	9	25,29,29	1.62	4 (16%)	33,38,38	1.64	3 (9%)

In the following table, the Chirals column lists the number of chiral outliers, the number of chiral centers analysed, the number of these observed in the model and the number defined in the Chemical Component Dictionary. Similar counts are reported in the Torsion and Rings columns. '-' means no outliers of that kind were identified.

Mol	Type	Chain	Res	Link	Chirals	Torsions	Rings
15	BO2	L	301	12	-	8/23/28/28	0/2/2/2
15	BO2	I	301	9	-	3/23/28/28	0/2/2/2
15	BO2	H	301	8	-	10/23/28/28	0/2/2/2
15	BO2	Z	301	12	-	8/23/28/28	0/2/2/2
15	BO2	V	301	8	-	10/23/28/28	0/2/2/2
15	BO2	W	301	9	-	3/23/28/28	0/2/2/2

The worst 5 of 24 bond length outliers are listed below:

Mol	Chain	Res	Type	Atoms	Z	Observed(Å)	Ideal(Å)
15	W	301	BO2	C18-N20	5.10	1.45	1.34
15	I	301	BO2	C18-N20	5.10	1.45	1.34
15	L	301	BO2	C18-N20	4.96	1.44	1.34
15	Z	301	BO2	C18-N20	4.96	1.44	1.34
15	H	301	BO2	C18-N20	4.83	1.44	1.34

The worst 5 of 18 bond angle outliers are listed below:

Mol	Chain	Res	Type	Atoms	Z	Observed(°)	Ideal(°)
15	W	301	BO2	C21-C22-C23	-6.10	107.53	115.32
15	I	301	BO2	C21-C22-C23	-6.06	107.58	115.32
15	V	301	BO2	C21-C22-C23	-5.07	108.85	115.32
15	H	301	BO2	C21-C22-C23	-5.05	108.87	115.32
15	W	301	BO2	C12-C11-C10	-2.89	105.67	113.36

There are no chirality outliers.

5 of 42 torsion outliers are listed below:

Mol	Chain	Res	Type	Atoms
15	H	301	BO2	C3-C2-C7-O8
15	H	301	BO2	C3-C2-C7-N9
15	I	301	BO2	C21-C22-C23-C25
15	L	301	BO2	B26-C21-C22-C23
15	V	301	BO2	C3-C2-C7-O8

There are no ring outliers.

6 monomers are involved in 19 short contacts:

Mol	Chain	Res	Type	Clashes	Symm-Clashes
15	L	301	BO2	2	0
15	I	301	BO2	2	0
15	H	301	BO2	4	0
15	Z	301	BO2	4	0
15	V	301	BO2	4	0
15	W	301	BO2	3	0

The following is a two-dimensional graphical depiction of Mogul quality analysis of bond lengths, bond angles, torsion angles, and ring geometry for all instances of the Ligand of Interest. In addition, ligands with molecular weight > 250 and outliers as shown on the validation Tables will also be included. For torsion angles, if less than 5% of the Mogul distribution of torsion angles is within 10 degrees of the torsion angle in question, then that torsion angle is considered an outlier.

Any bond that is central to one or more torsion angles identified as an outlier by Mogul will be highlighted in the graph. For rings, the root-mean-square deviation (RMSD) between the ring in question and similar rings identified by Mogul is calculated over all ring torsion angles. If the average RMSD is greater than 60 degrees and the minimal RMSD between the ring in question and any Mogul-identified rings is also greater than 60 degrees, then that ring is considered an outlier. The outliers are highlighted in purple. The color gray indicates Mogul did not find sufficient equivalents in the CSD to analyse the geometry.

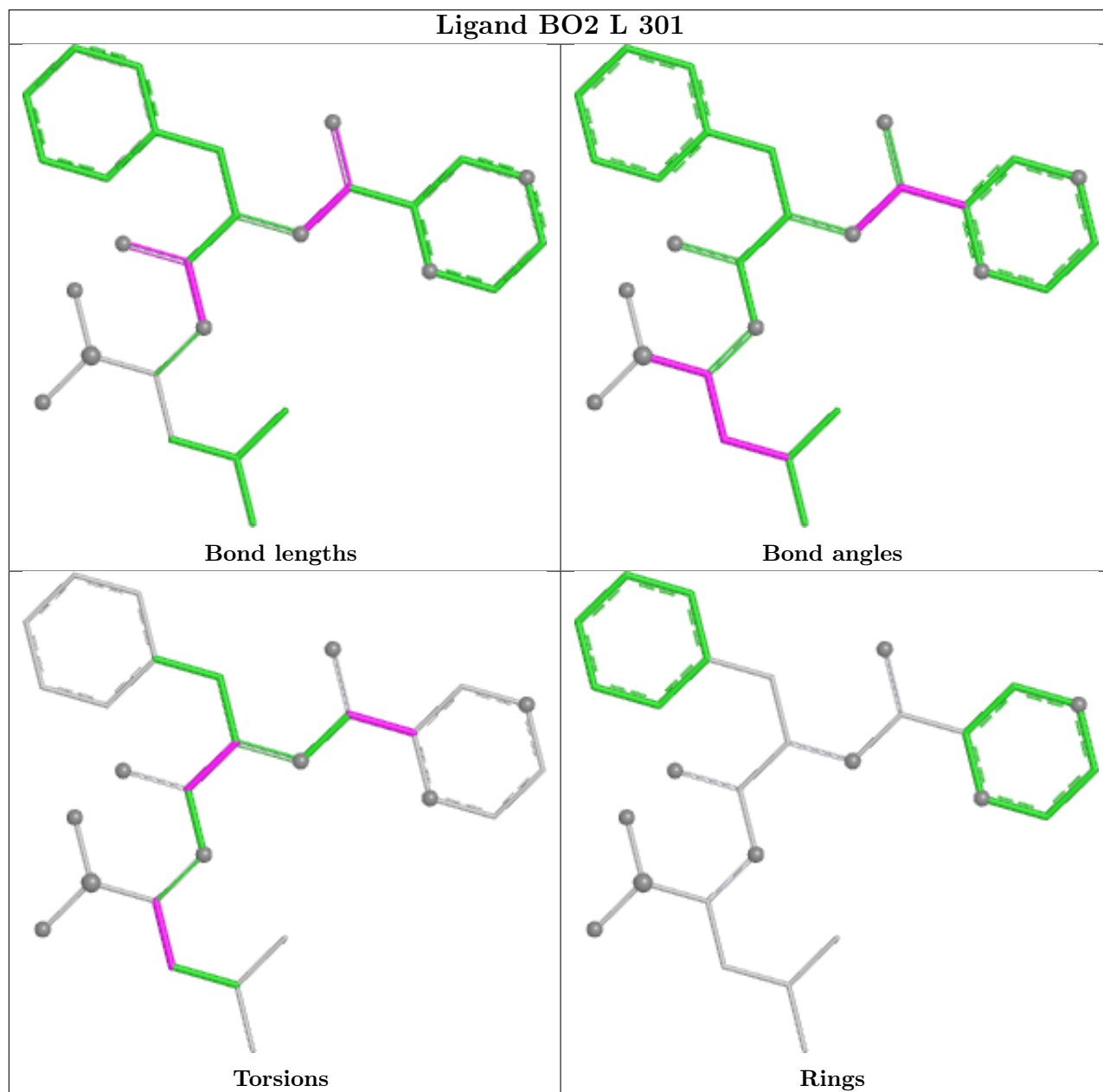

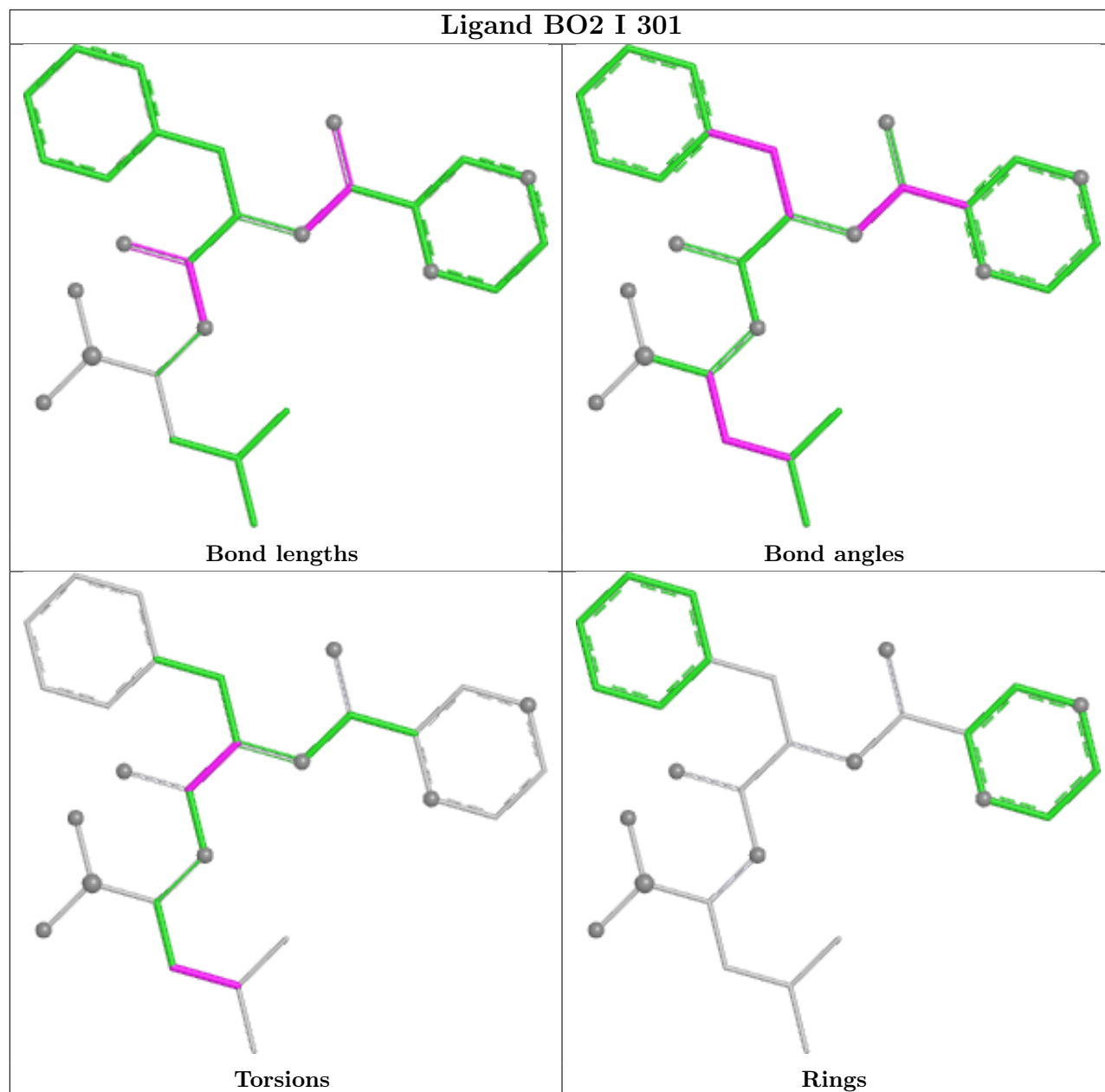

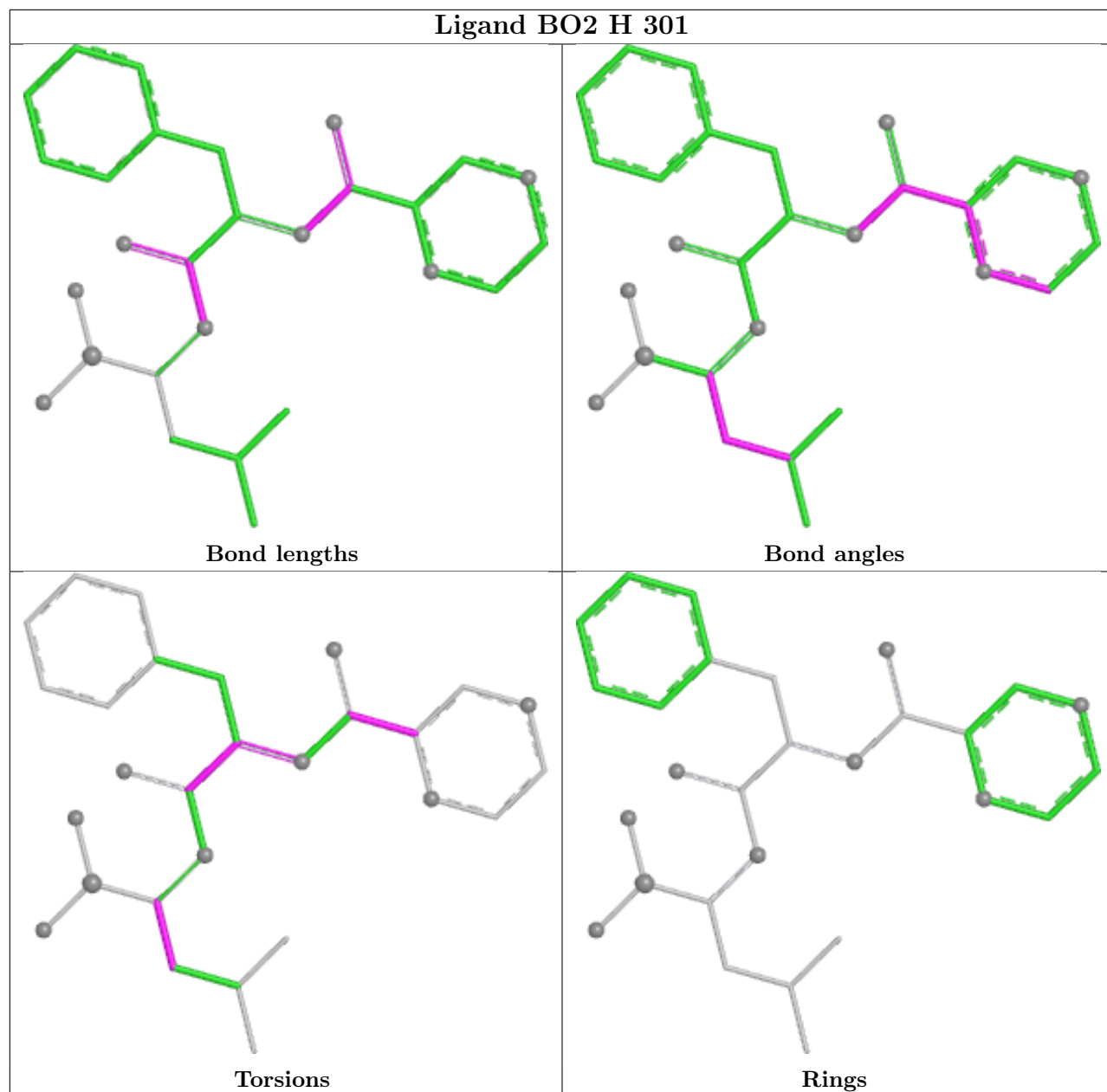

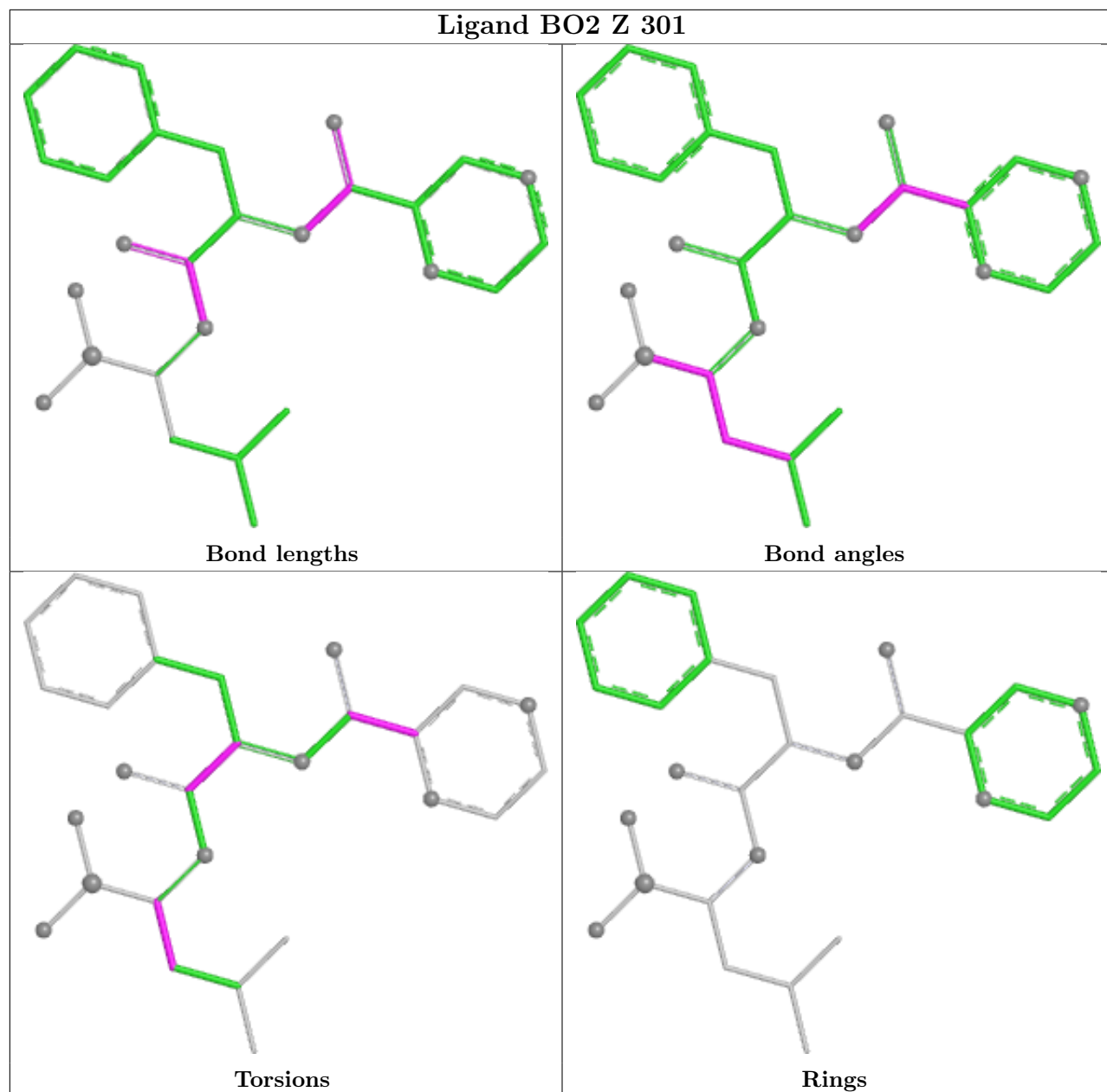

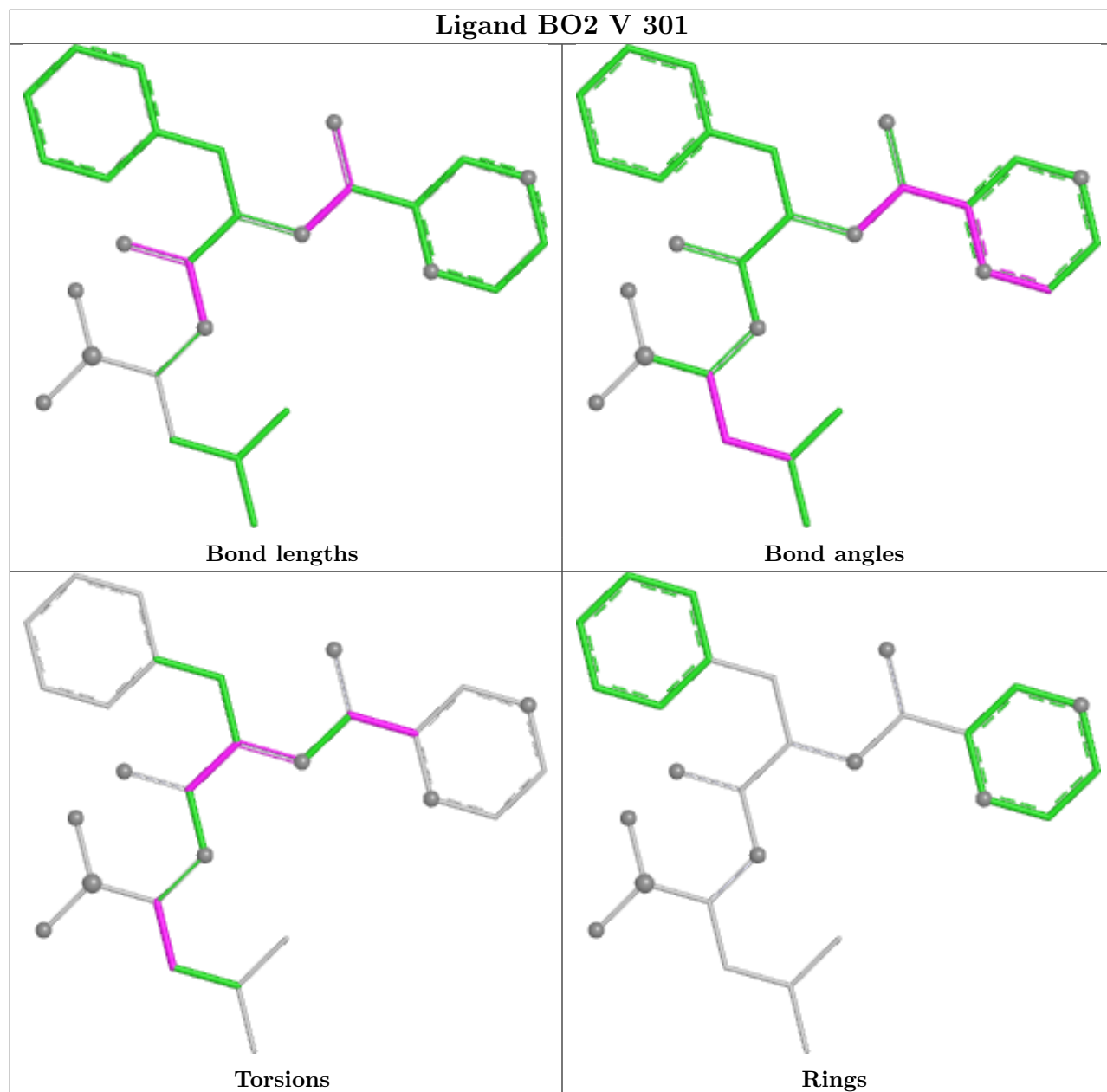

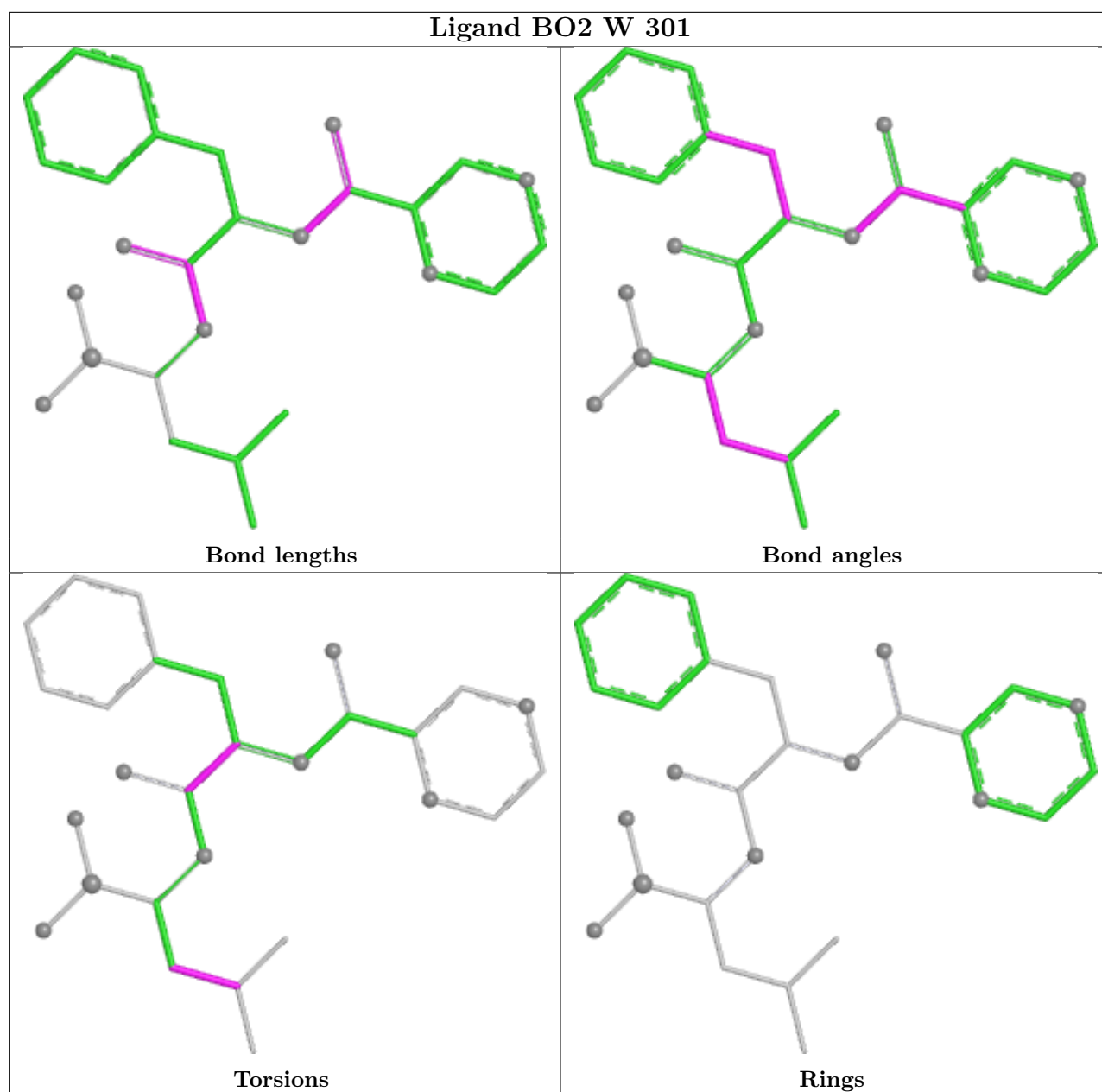

5.7 Other polymers [\(i\)](#)

There are no such residues in this entry.

5.8 Polymer linkage issues [\(i\)](#)

There are no chain breaks in this entry.

6 Map visualisation [i](#)

This section contains visualisations of the EMDB entry EMD-23574. These allow visual inspection of the internal detail of the map and identification of artifacts.

Images derived from a raw map, generated by summing the deposited half-maps, are presented below the corresponding image components of the primary map to allow further visual inspection and comparison with those of the primary map.

6.1 Orthogonal projections [i](#)

6.1.1 Primary map

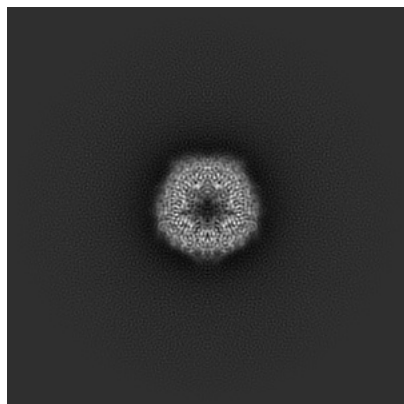

X

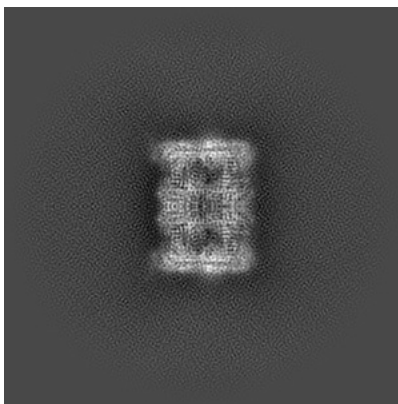

Y

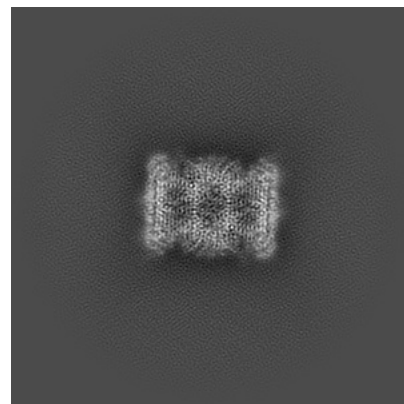

Z

6.1.2 Raw map

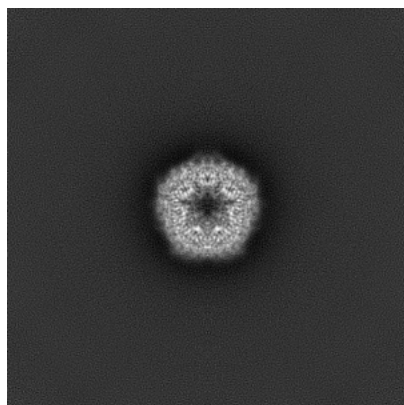

X

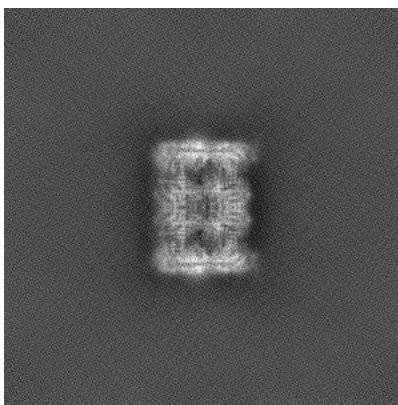

Y

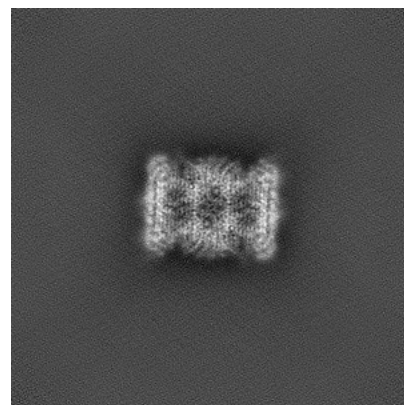

Z

The images above show the map projected in three orthogonal directions.

6.2 Central slices [i](#)

6.2.1 Primary map

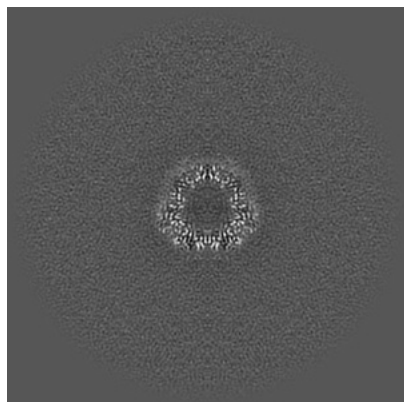

X Index: 172

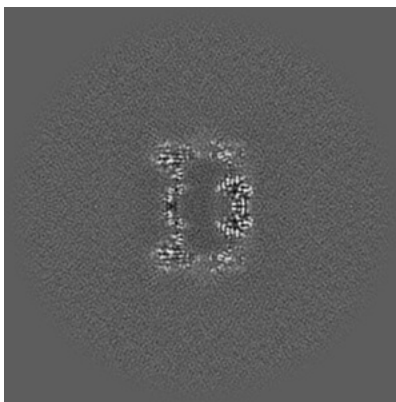

Y Index: 172

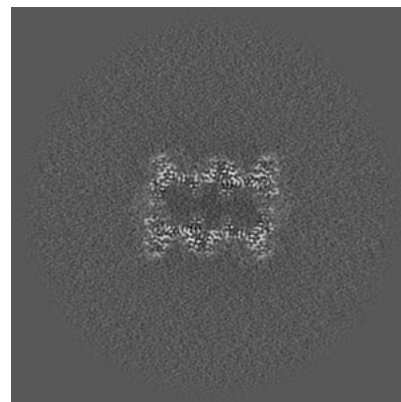

Z Index: 172

6.2.2 Raw map

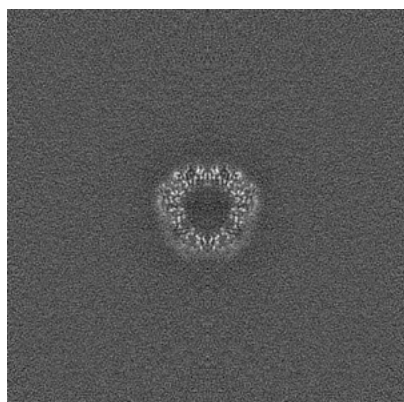

X Index: 172

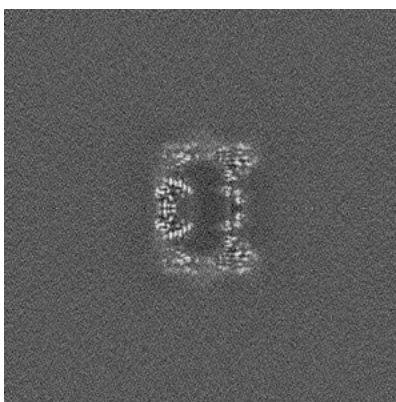

Y Index: 172

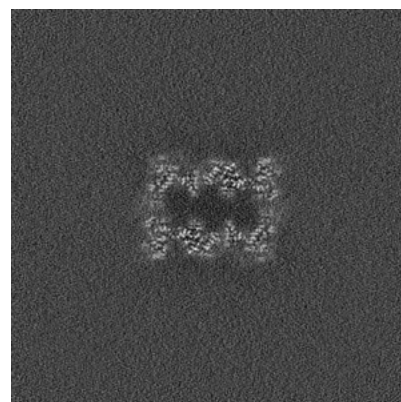

Z Index: 172

The images above show central slices of the map in three orthogonal directions.

6.3 Largest variance slices [i](#)

6.3.1 Primary map

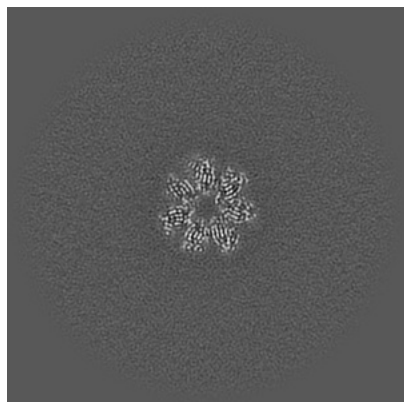

X Index: 186

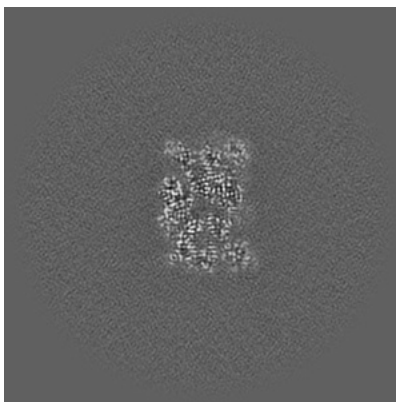

Y Index: 191

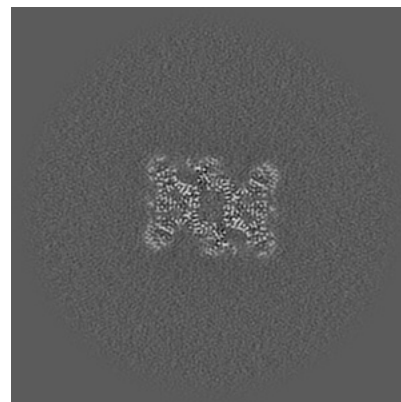

Z Index: 152

6.3.2 Raw map

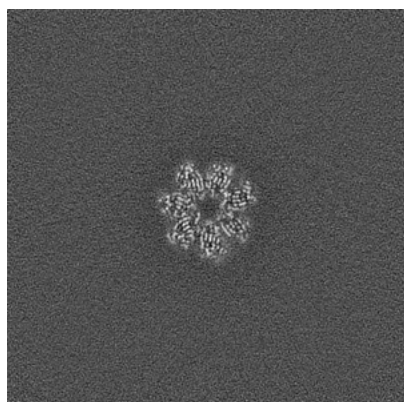

X Index: 158

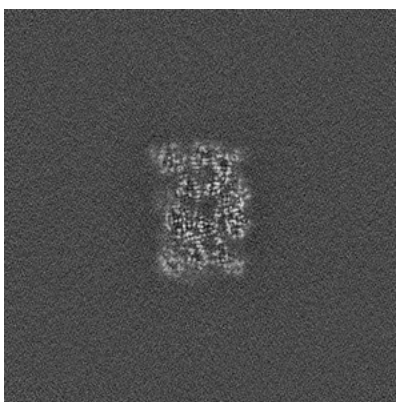

Y Index: 153

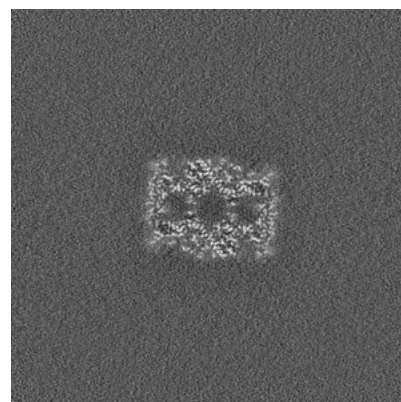

Z Index: 185

The images above show the largest variance slices of the map in three orthogonal directions.

6.4 Orthogonal standard-deviation projections (False-color) [i](#)

6.4.1 Primary map

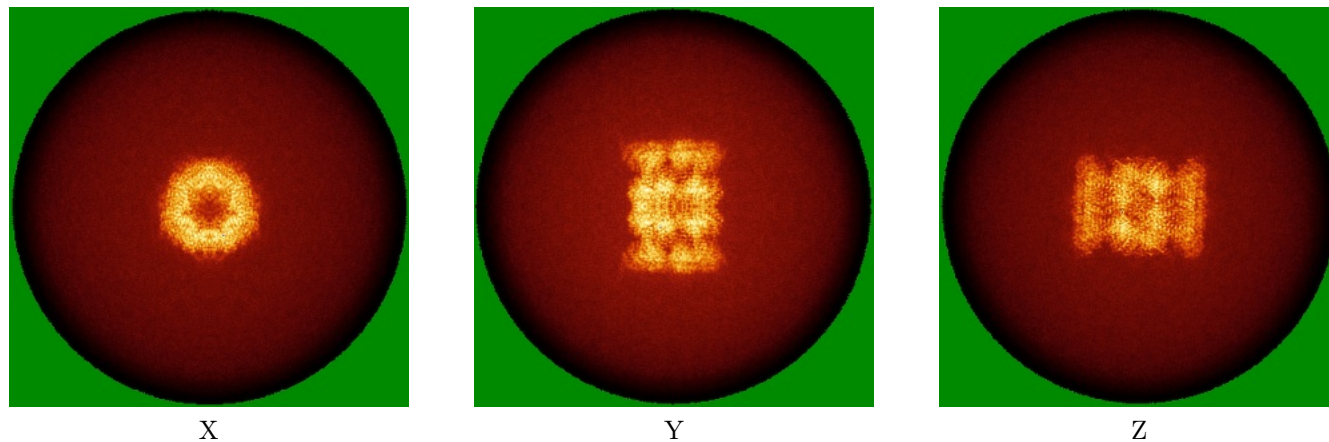

6.4.2 Raw map

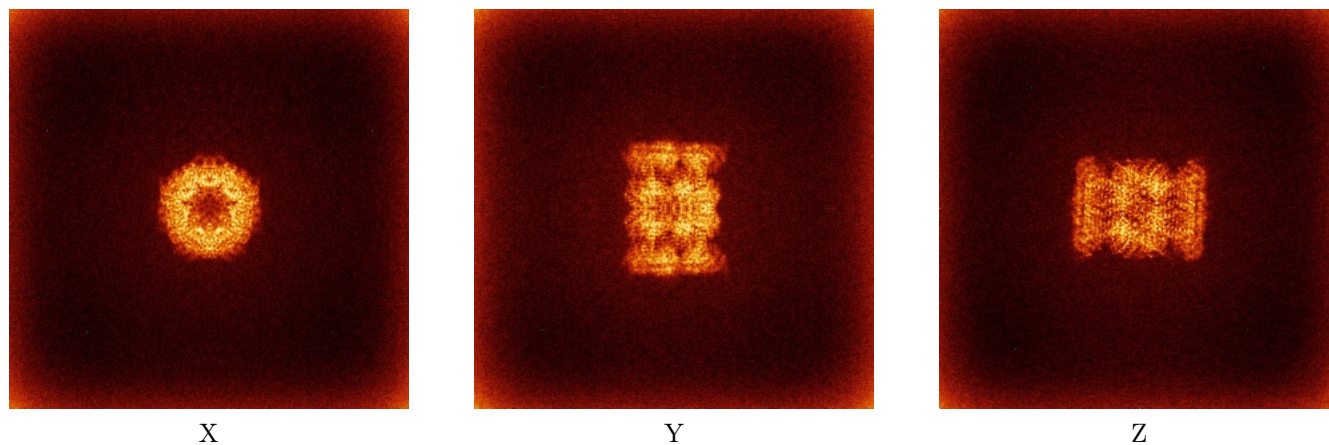

The images above show the map standard deviation projections with false color in three orthogonal directions. Minimum values are shown in green, max in blue, and dark to light orange shades represent small to large values respectively.

6.5 Orthogonal surface views [i](#)

6.5.1 Primary map

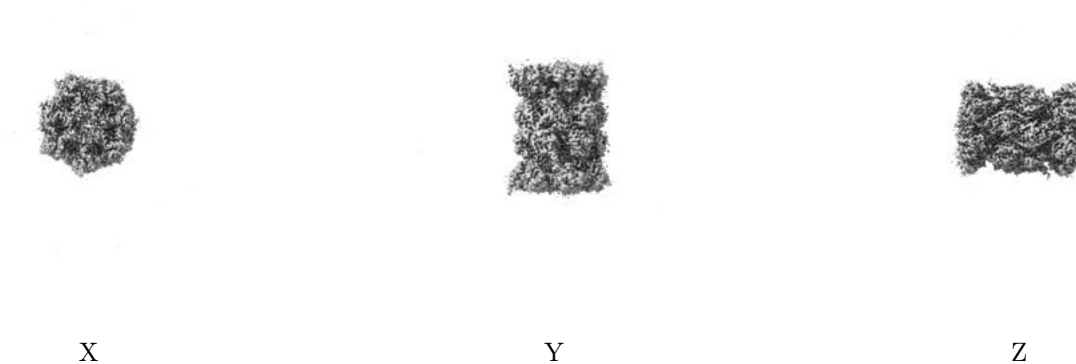

The images above show the 3D surface view of the map at the recommended contour level 5.0. These images, in conjunction with the slice images, may facilitate assessment of whether an appropriate contour level has been provided.

6.5.2 Raw map

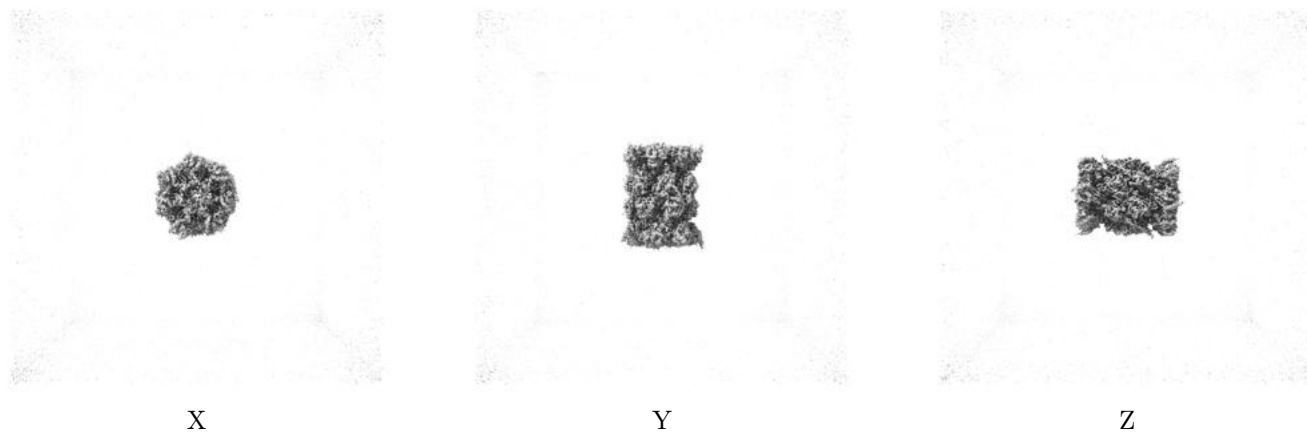

These images show the 3D surface of the raw map. The raw map's contour level was selected so that its surface encloses the same volume as the primary map does at its recommended contour level.

6.6 Mask visualisation [i](#)

This section was not generated. No masks/segmentation were deposited.

7 Map analysis [i](#)

This section contains the results of statistical analysis of the map.

7.1 Map-value distribution [i](#)

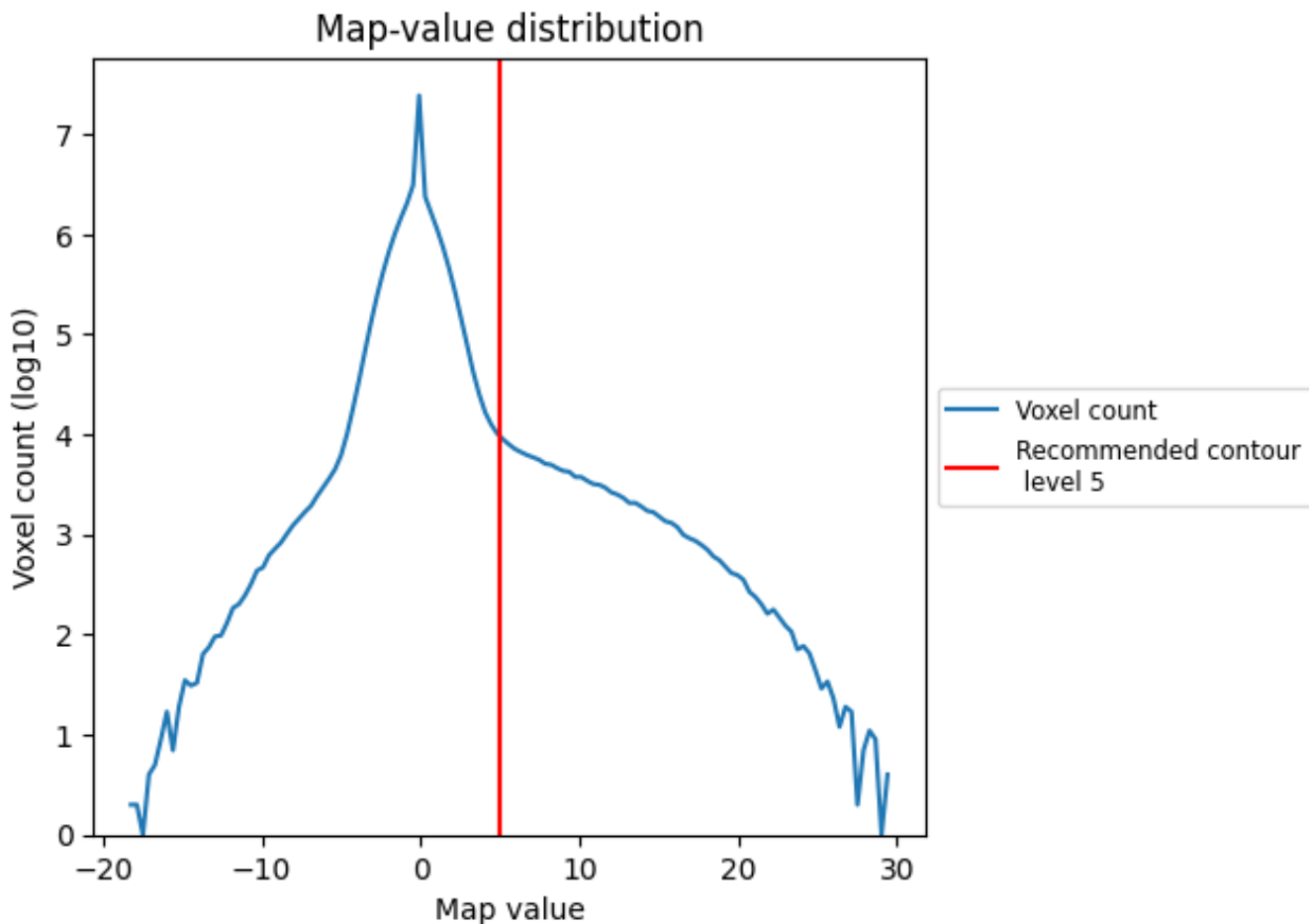

The map-value distribution is plotted in 128 intervals along the x-axis. The y-axis is logarithmic. A spike in this graph at zero usually indicates that the volume has been masked.

7.2 Volume estimate [\(i\)](#)

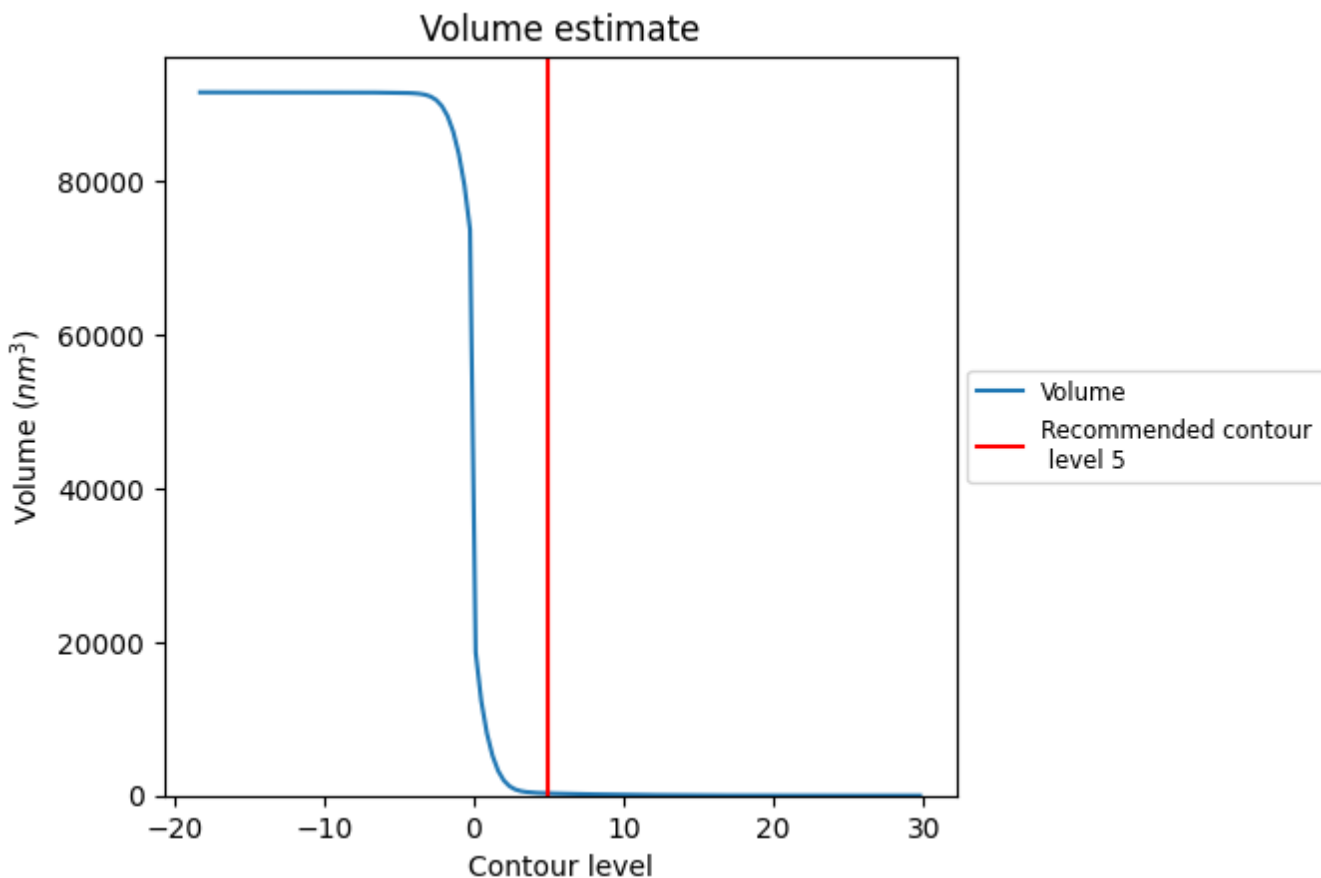

The volume at the recommended contour level is 288 nm³; this corresponds to an approximate mass of 260 kDa.

The volume estimate graph shows how the enclosed volume varies with the contour level. The recommended contour level is shown as a vertical line and the intersection between the line and the curve gives the volume of the enclosed surface at the given level.

7.3 Rotationally averaged power spectrum [i](#)

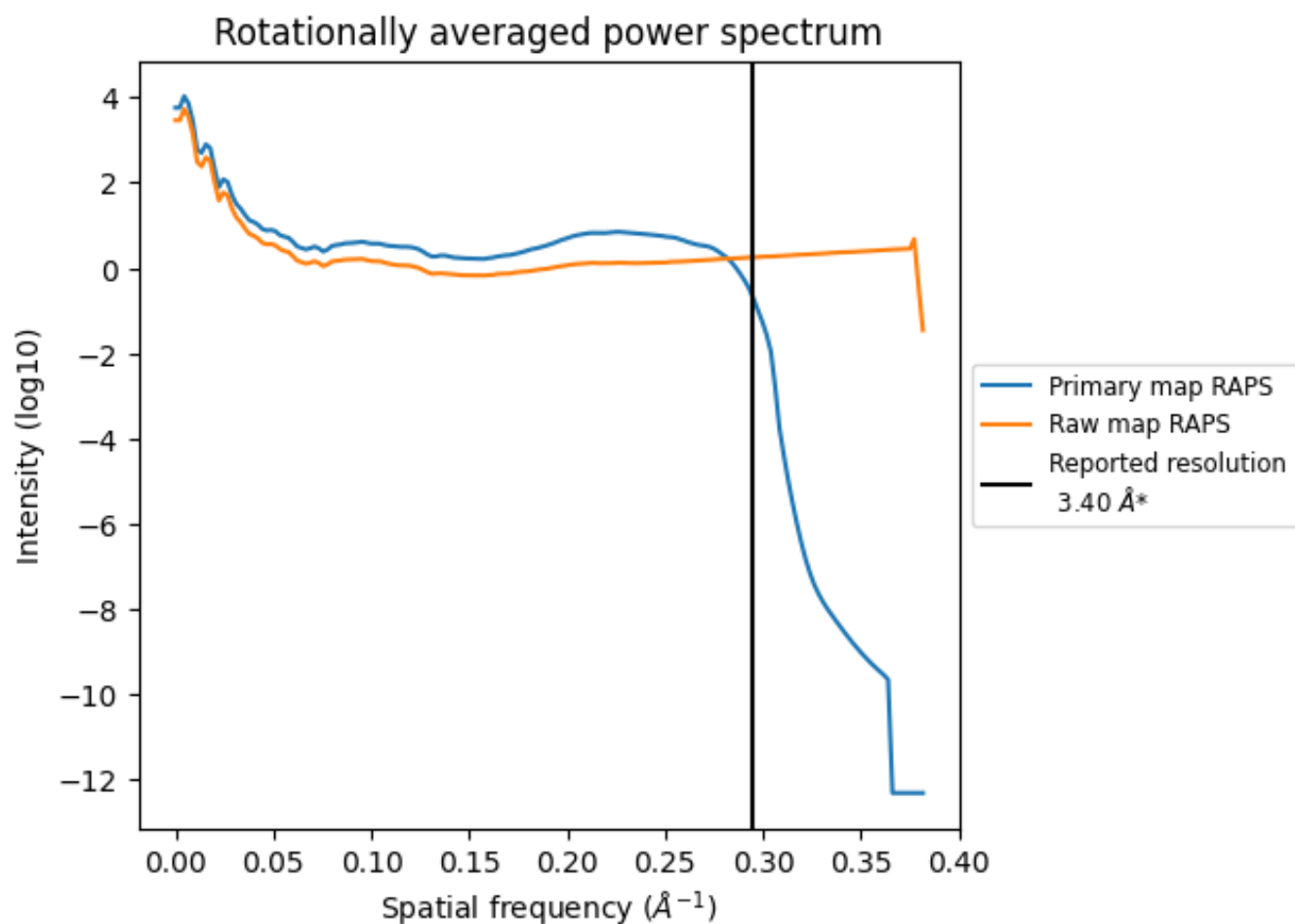

*Reported resolution corresponds to spatial frequency of 0.294 Å⁻¹

8 Fourier-Shell correlation [i](#)

Fourier-Shell Correlation (FSC) is the most commonly used method to estimate the resolution of single-particle and subtomogram-averaged maps. The shape of the curve depends on the imposed symmetry, mask and whether or not the two 3D reconstructions used were processed from a common reference. The reported resolution is shown as a black line. A curve is displayed for the half-bit criterion in addition to lines showing the 0.143 gold standard cut-off and 0.5 cut-off.

8.1 FSC [i](#)

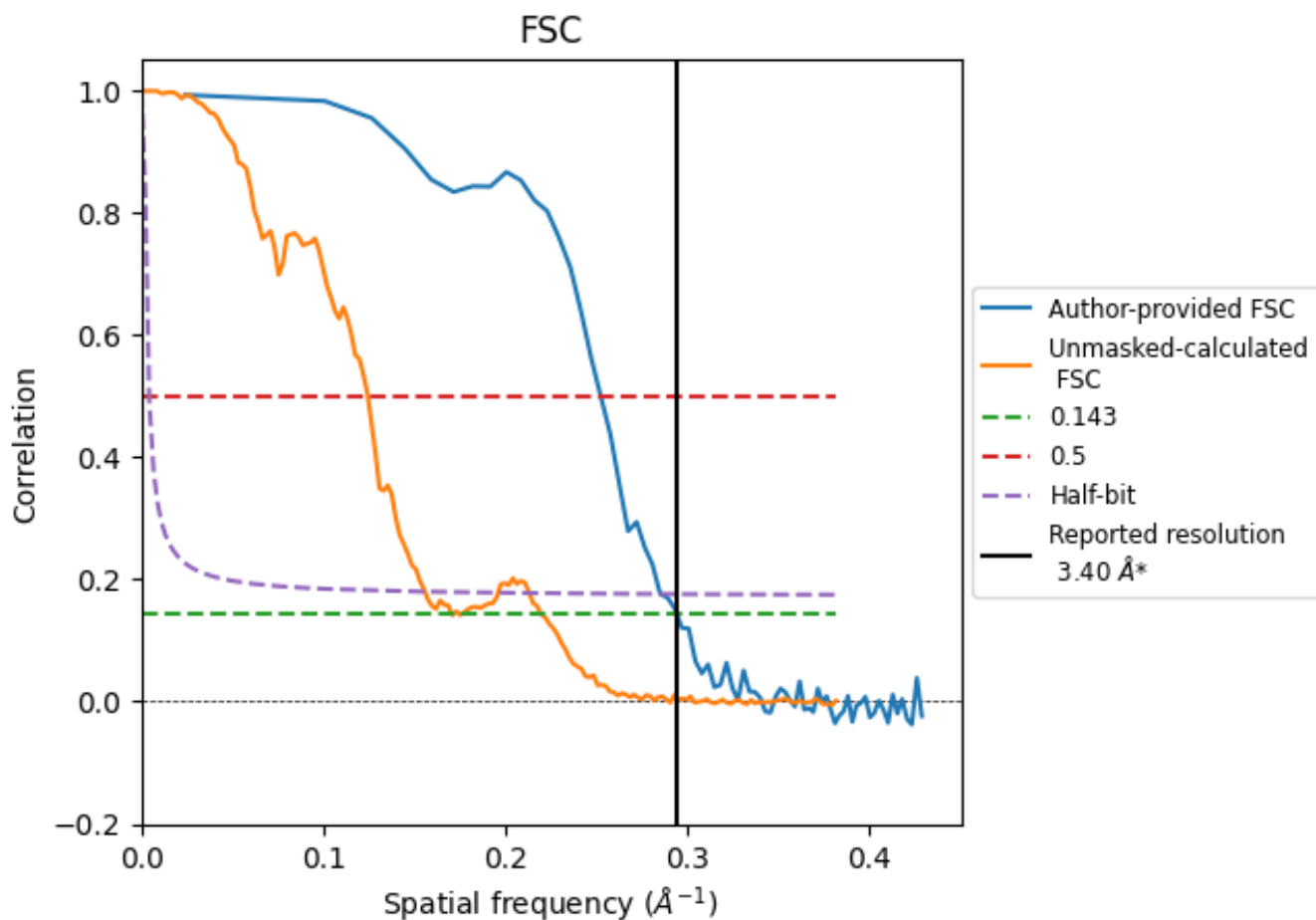

*Reported resolution corresponds to spatial frequency of 0.294 Å⁻¹

8.2 Resolution estimates [i](#)

Resolution estimate (Å)	Estimation criterion (FSC cut-off)		
	0.143	0.5	Half-bit
Reported by author	3.40	-	-
Author-provided FSC curve	3.40	3.96	3.53
Unmasked-calculated*	5.86	8.04	6.41

*Resolution estimate based on FSC curve calculated by comparison of deposited half-maps. The value from deposited half-maps intersecting FSC 0.143 CUT-OFF 5.86 differs from the reported value 3.4 by more than 10 %

9 Map-model fit [i](#)

This section contains information regarding the fit between EMDB map EMD-23574 and PDB model 7LXT. Per-residue inclusion information can be found in section 3 on page 8.

9.1 Map-model overlay [i](#)

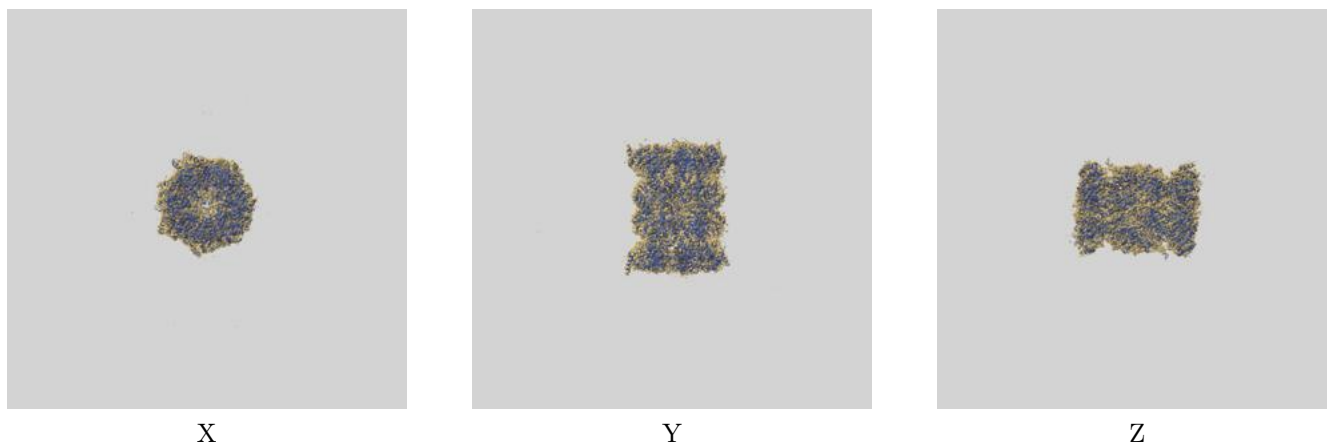

The images above show the 3D surface view of the map at the recommended contour level 5.0 at 50% transparency in yellow overlaid with a ribbon representation of the model coloured in blue. These images allow for the visual assessment of the quality of fit between the atomic model and the map.

9.2 Q-score mapped to coordinate model [i](#)

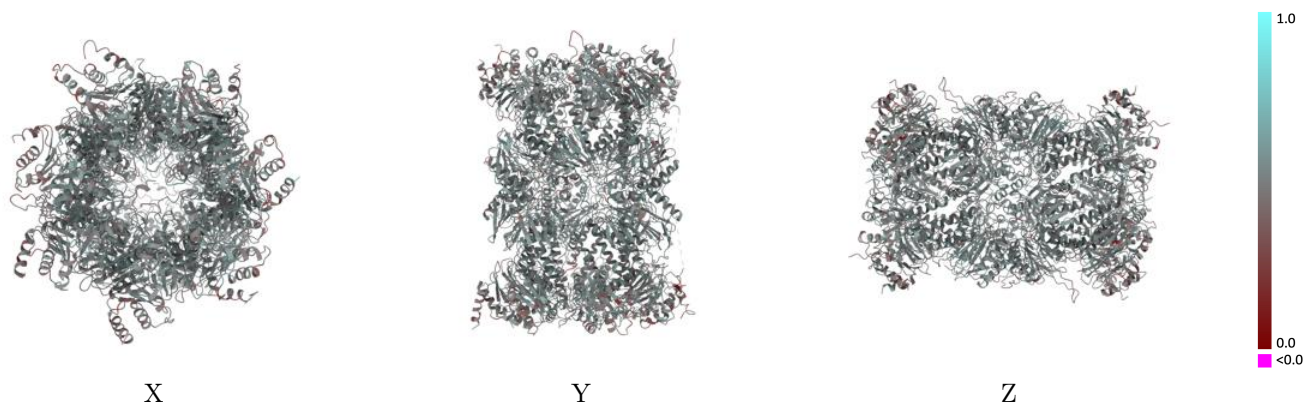

The images above show the model with each residue coloured according to its Q-score. This shows their resolvability in the map with higher Q-score values reflecting better resolvability. Please note: Q-score is calculating the resolvability of atoms, and thus high values are only expected at resolutions at which atoms can be resolved. Low Q-score values may therefore be expected for many entries.

9.3 Atom inclusion mapped to coordinate model [i](#)

This section was not generated.



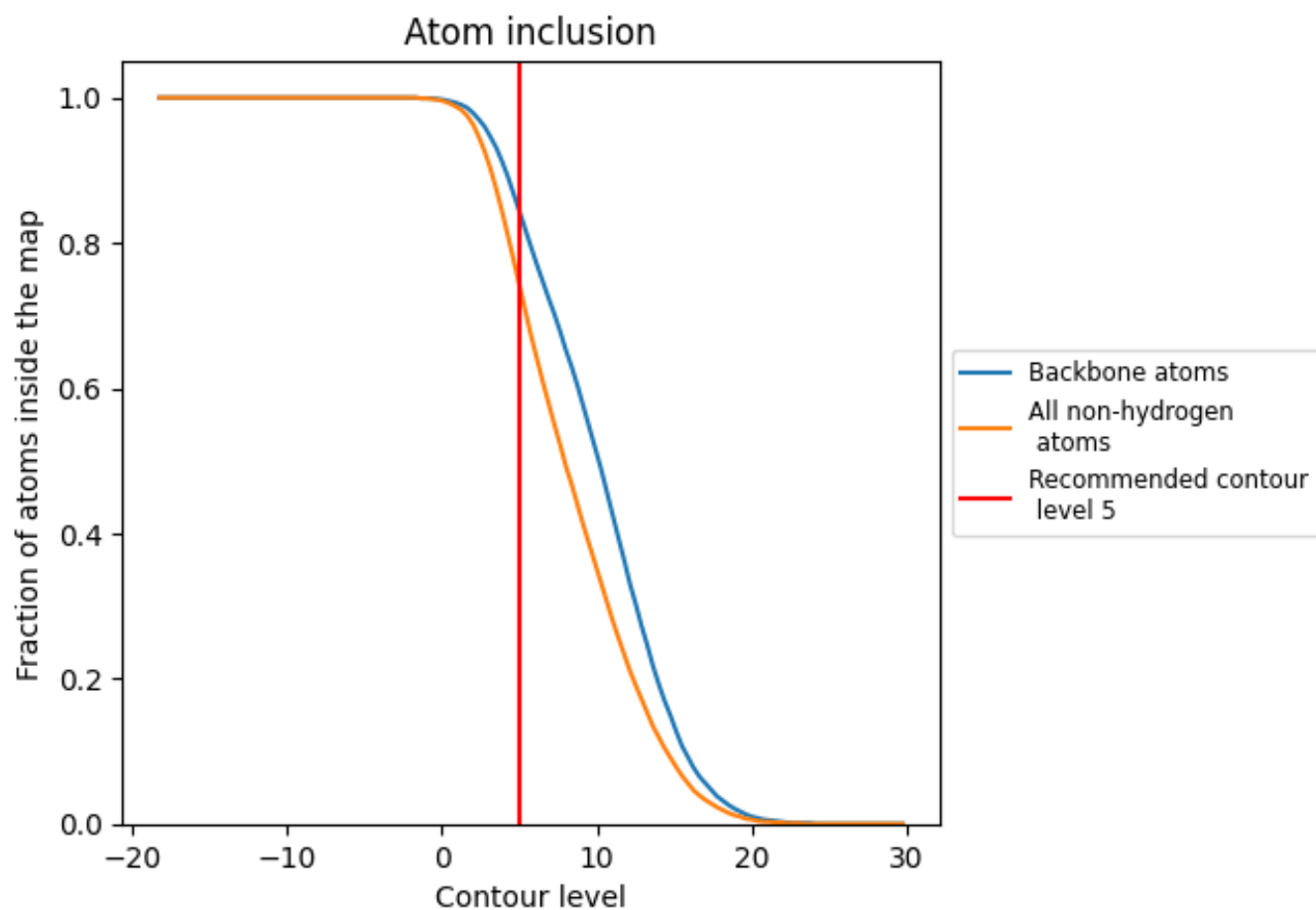























































9.4 Atom inclusion [i](#)



At the recommended contour level, 84% of all backbone atoms, 74% of all non-hydrogen atoms, are inside the map.

9.5 Map-model fit summary [i](#)

The table lists the average atom inclusion at the recommended contour level (5) and Q-score for the entire model and for each chain.

Chain	Atom inclusion	Q-score
All	 0.7420	 0.4980
A	 0.6590	 0.4730
B	 0.6870	 0.4870
C	 0.7180	 0.4860
D	 0.6990	 0.4780
E	 0.6910	 0.4900
F	 0.7290	 0.4920
G	 0.7270	 0.4960
H	 0.7780	 0.5110
I	 0.7740	 0.4980
J	 0.7720	 0.5050
K	 0.8130	 0.5170
L	 0.8170	 0.5150
M	 0.7900	 0.5130
N	 0.7590	 0.5150
O	 0.6570	 0.4730
P	 0.6880	 0.4840
Q	 0.7210	 0.4880
R	 0.7000	 0.4780
S	 0.6900	 0.4930
T	 0.7280	 0.4920
U	 0.7220	 0.4950
V	 0.7790	 0.5130
W	 0.7730	 0.5000
X	 0.7750	 0.5050
Y	 0.8100	 0.5150
Z	 0.8190	 0.5140
a	 0.7920	 0.5150
b	 0.7590	 0.5130

