



wwPDB EM Validation Summary Report ⓘ

Mar 9, 2026 – 05:07 PM UTC

PDB ID : 5MPB / pdb_00005mpb
EMDB ID : EMD-3536
Title : 26S proteasome in presence of AMP-PNP (s3)
Authors : Wehmer, M.; Rudack, T.; Beck, F.; Aufderheide, A.; Pfeifer, G.; Plitzko, J.M.;
Foerster, F.; Schulten, K.; Baumeister, W.; Sakata, E.
Deposited on : 2016-12-16
Resolution : 7.80 Å(reported)

This is a wwPDB EM Validation Summary Report for a publicly released PDB entry.

We welcome your comments at validation@mail.wwpdb.org

A user guide is available at

<https://www.wwpdb.org/validation/2017/EMValidationReportHelp>

with specific help available everywhere you see the ⓘ symbol.

The types of validation reports are described at

<http://www.wwpdb.org/validation/2017/FAQs#types>.

The following versions of software and data (see [references ⓘ](#)) were used in the production of this report:

EMDB validation analysis : 0.0.1.dev132
Mogul : 2022.3.0, CSD as543be (2022)
MolProbity : 4-5-2 with Phenix2.0
Buster-report : wwPDB partial adaption of 1.1.7 (2018)
Percentile statistics : 20250101.v01 (using entries in the PDB archive January 1st 2025)
EM percentile statistics : 202505.v01 (Using data in the EMDB archive up until May 2025)
MapQ : 1.9.13
Ideal geometry (proteins) : Engh & Huber (2001)
Ideal geometry (DNA, RNA) : Parkinson et al. (1996)
Validation Pipeline (wwPDB-VP) : 2.49

1 Overall quality at a glance i

The following experimental techniques were used to determine the structure:
ELECTRON MICROSCOPY

The reported resolution of this entry is 7.80 Å.

Percentile scores (ranging between 0-100) for global validation metrics of the entry are shown in the following graphic. The table shows the number of entries on which the scores are based.

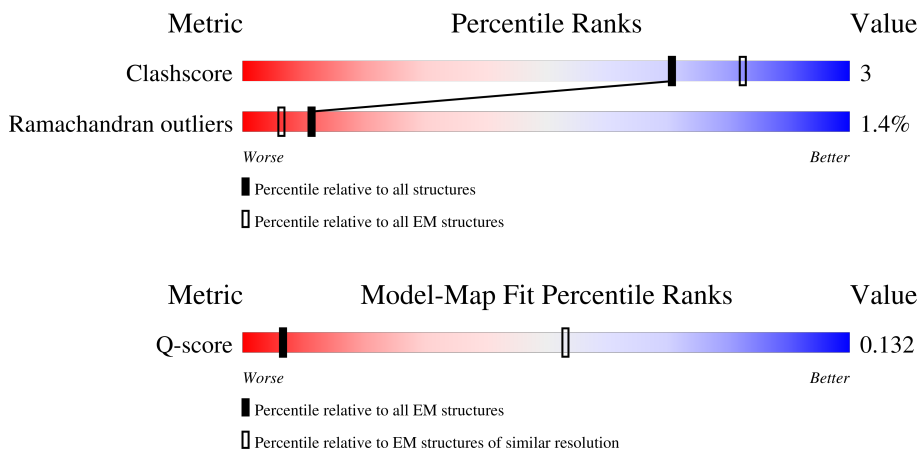

Metric	Whole archive (#Entries)	EM structures (#Entries)	Similar EM resolution (#Entries, resolution range(Å))
Clashscore	229148	23984	-
Ramachandran outliers	224038	23583	-
Q-score	-	25397	370 (7.30 - 8.30)

The table below summarises the geometric issues observed across the polymeric chains and their fit to the map. The red, orange, yellow and green segments of the bar indicate the fraction of residues that contain outliers for ≥ 3 , 2, 1 and 0 types of geometric quality criteria respectively. A grey segment represents the fraction of residues that are not modelled. The numeric value for each fraction is indicated below the corresponding segment, with a dot representing fractions $\leq 5\%$. The upper red bar (where present) indicates the fraction of residues that have poor fit to the EM map (all-atom inclusion $< 40\%$). The numeric value is given above the bar.

Mol	Chain	Length	Quality of chain
1	A	252	<div style="display: flex; align-items: center;"> <div style="width: 21%; height: 10px; background-color: red; margin-right: 5px;"></div> <div style="width: 32%; height: 10px; background-color: orange; margin-right: 5px;"></div> <div style="width: 32%; height: 10px; background-color: yellow; margin-right: 5px;"></div> <div style="width: 15%; height: 10px; background-color: green; margin-right: 5px;"></div> <div style="width: 10%; height: 10px; background-color: grey;"></div> </div> <p style="text-align: center;">21% 53% 38% . .</p>
1	a	252	<div style="display: flex; align-items: center;"> <div style="width: 20%; height: 10px; background-color: red; margin-right: 5px;"></div> <div style="width: 25%; height: 10px; background-color: orange; margin-right: 5px;"></div> <div style="width: 21%; height: 10px; background-color: yellow; margin-right: 5px;"></div> <div style="width: 34%; height: 10px; background-color: green; margin-right: 5px;"></div> <div style="width: 10%; height: 10px; background-color: grey;"></div> </div> <p style="text-align: center;">20% 45% 46% 5% .</p>
2	B	250	<div style="display: flex; align-items: center;"> <div style="width: 26%; height: 10px; background-color: red; margin-right: 5px;"></div> <div style="width: 30%; height: 10px; background-color: orange; margin-right: 5px;"></div> <div style="width: 44%; height: 10px; background-color: yellow; margin-right: 5px;"></div> <div style="width: 10%; height: 10px; background-color: green; margin-right: 5px;"></div> <div style="width: 10%; height: 10px; background-color: grey;"></div> </div> <p style="text-align: center;">26% 56% 40% .</p>
2	b	250	<div style="display: flex; align-items: center;"> <div style="width: 26%; height: 10px; background-color: red; margin-right: 5px;"></div> <div style="width: 25%; height: 10px; background-color: orange; margin-right: 5px;"></div> <div style="width: 49%; height: 10px; background-color: yellow; margin-right: 5px;"></div> <div style="width: 10%; height: 10px; background-color: green; margin-right: 5px;"></div> <div style="width: 10%; height: 10px; background-color: grey;"></div> </div> <p style="text-align: center;">26% 51% 44% .</p>
3	C	258	<div style="display: flex; align-items: center;"> <div style="width: 18%; height: 10px; background-color: red; margin-right: 5px;"></div> <div style="width: 42%; height: 10px; background-color: orange; margin-right: 5px;"></div> <div style="width: 40%; height: 10px; background-color: yellow; margin-right: 5px;"></div> <div style="width: 10%; height: 10px; background-color: green; margin-right: 5px;"></div> <div style="width: 10%; height: 10px; background-color: grey;"></div> </div> <p style="text-align: center;">18% 60% 33% . 5%</p>













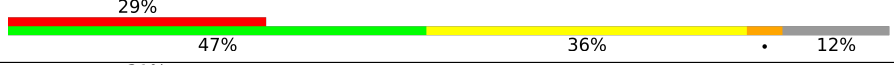

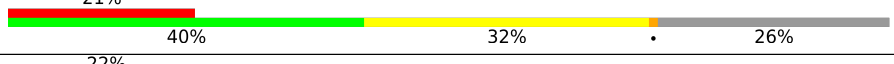
Continued on next page...

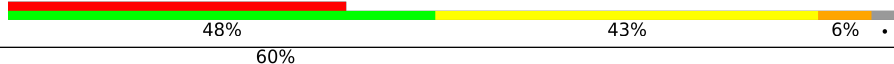
Continued from previous page...

Mol	Chain	Length	Quality of chain
3	c	258	22% 47% 44% 5%
4	D	254	13% 55% 38% 6%
4	d	254	16% 44% 48% 6%
5	E	260	17% 53% 37% 7%
5	e	260	22% 48% 42% 7%
6	F	234	16% 62% 34% .
6	f	234	20% 46% 50% ..
7	G	288	11% 48% 34% . 16%
7	g	288	14% 41% 41% . 16%
8	1	215	12% 57% 32% . 9%
8	h	215	13% 45% 42% . 9%
9	2	261	13% 51% 34% .. 13%
9	i	261	21% 38% 46% . 13%
10	3	205	24% 56% 41% .
10	j	205	24% 44% 50% 5%
11	4	198	12% 57% 38%
11	k	198	14% 48% 47% .. .
12	5	287	9% 51% 22% . 26%
12	l	287	10% 34% 37% . 26%
13	6	241	13% 53% 36% . 8%
13	m	241	16% 41% 49% . 8%
14	7	266	13% 48% 34% . 14%
14	n	266	15% 40% 43% . 13%
15	H	467	22% 44% 35% . 19%
16	I	437	40% 45% 40% . 12%

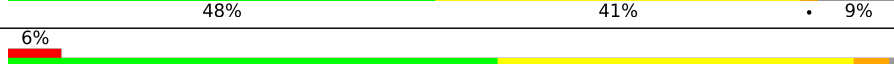
Continued on next page...

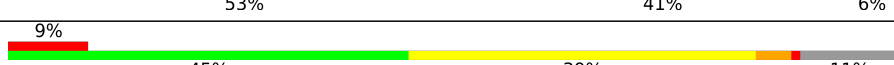
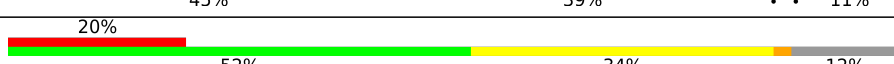
Continued from previous page...

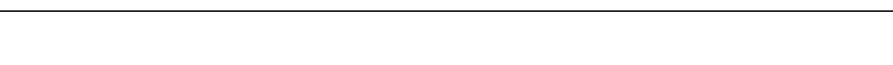
Mol	Chain	Length	Quality of chain
17	K	428	
18	L	437	
19	M	434	
20	J	405	
21	W	268	
22	V	306	
23	T	274	
24	X	156	
25	Y	89	
26	Z	993	
27	N	945	
28	S	523	
29	P	445	
30	Q	434	
31	R	429	
32	U	338	
33	O	393	

The following table lists non-polymeric compounds, carbohydrate monomers and non-standard residues in protein, DNA, RNA chains that are outliers for geometric or electron-density-fit criteria:

Mol	Type	Chain	Res	Chirality	Geometry	Clashes	Electron density
36	ADP	M	501	-	-	X	-

2 Entry composition [i](#)

There are 36 unique types of molecules in this entry. The entry contains 108771 atoms, of which 0 are hydrogens and 0 are deuteriums.

In the tables below, the AltConf column contains the number of residues with at least one atom in alternate conformation and the Trace column contains the number of residues modelled with at most 2 atoms.

- Molecule 1 is a protein called Proteasome subunit alpha type-1.

Mol	Chain	Residues	Atoms					AltConf	Trace
			Total	C	N	O	S		
1	a	241	Total	C	N	O	S	0	0
			1907	1214	320	365	8		
1	A	241	Total	C	N	O	S	0	0
			1907	1214	320	365	8		

- Molecule 2 is a protein called Proteasome subunit alpha type-2.

Mol	Chain	Residues	Atoms					AltConf	Trace
			Total	C	N	O	S		
2	b	250	Total	C	N	O	S	0	0
			1915	1219	315	377	4		
2	B	250	Total	C	N	O	S	0	0
			1915	1219	315	377	4		

- Molecule 3 is a protein called Proteasome subunit alpha type-3.

Mol	Chain	Residues	Atoms					AltConf	Trace
			Total	C	N	O	S		
3	c	244	Total	C	N	O	S	0	0
			1904	1201	321	379	3		
3	C	244	Total	C	N	O	S	0	0
			1904	1201	321	379	3		

- Molecule 4 is a protein called Proteasome subunit alpha type-4.

Mol	Chain	Residues	Atoms					AltConf	Trace
			Total	C	N	O	S		
4	d	240	Total	C	N	O	S	0	0
			1881	1176	329	372	4		
4	D	240	Total	C	N	O	S	0	0
			1881	1176	329	372	4		

- Molecule 5 is a protein called Proteasome subunit alpha type-5.

Mol	Chain	Residues	Atoms					AltConf	Trace
5	e	242	Total	C	N	O	S	0	0
			1861	1162	314	378	7		
5	E	242	Total	C	N	O	S	0	0
			1861	1162	314	378	7		

- Molecule 6 is a protein called Proteasome subunit alpha type-6.

Mol	Chain	Residues	Atoms					AltConf	Trace
6	f	231	Total	C	N	O	S	0	0
			1773	1114	307	348	4		
6	F	233	Total	C	N	O	S	0	0
			1795	1129	312	350	4		

- Molecule 7 is a protein called Probable proteasome subunit alpha type-7.

Mol	Chain	Residues	Atoms					AltConf	Trace
7	g	243	Total	C	N	O	S	0	0
			1892	1203	329	356	4		
7	G	243	Total	C	N	O	S	0	0
			1892	1203	329	356	4		

- Molecule 8 is a protein called Proteasome subunit beta type-1.

Mol	Chain	Residues	Atoms					AltConf	Trace
8	h	196	Total	C	N	O	S	0	0
			1512	955	250	300	7		
8	1	196	Total	C	N	O	S	0	0
			1512	955	250	300	7		

- Molecule 9 is a protein called Proteasome subunit beta type-2.

Mol	Chain	Residues	Atoms					AltConf	Trace
9	i	226	Total	C	N	O	S	0	0
			1719	1082	298	332	7		
9	2	226	Total	C	N	O	S	0	0
			1719	1082	298	332	7		

- Molecule 10 is a protein called Proteasome subunit beta type-3.

Mol	Chain	Residues	Atoms					AltConf	Trace
10	j	204	Total	C	N	O	S	0	0
			1581	1010	258	305	8		

Continued on next page...

Continued from previous page...

Mol	Chain	Residues	Atoms					AltConf	Trace
10	3	204	Total	C	N	O	S	0	0
			1581	1010	258	305	8		

- Molecule 11 is a protein called Proteasome subunit beta type-4.

Mol	Chain	Residues	Atoms					AltConf	Trace
11	k	195	Total	C	N	O	S	0	0
			1561	992	264	299	6		
11	4	195	Total	C	N	O	S	0	0
			1561	992	264	299	6		

- Molecule 12 is a protein called Proteasome subunit beta type-5.

Mol	Chain	Residues	Atoms					AltConf	Trace
12	1	212	Total	C	N	O	S	0	0
			1644	1045	280	312	7		
12	5	212	Total	C	N	O	S	0	0
			1644	1045	280	312	7		

- Molecule 13 is a protein called Proteasome subunit beta type-6.

Mol	Chain	Residues	Atoms					AltConf	Trace
13	m	222	Total	C	N	O	S	0	0
			1757	1115	303	335	4		
13	6	222	Total	C	N	O	S	0	0
			1757	1115	303	335	4		

- Molecule 14 is a protein called Proteasome subunit beta type-7.

Mol	Chain	Residues	Atoms					AltConf	Trace
14	n	232	Total	C	N	O	S	0	0
			1815	1148	311	349	7		
14	7	229	Total	C	N	O	S	0	0
			1790	1133	306	344	7		

- Molecule 15 is a protein called 26S protease regulatory subunit 7 homolog.

Mol	Chain	Residues	Atoms					AltConf	Trace
15	H	380	Total	C	N	O	S	0	0
			2967	1869	531	551	16		

- Molecule 16 is a protein called 26S protease regulatory subunit 4 homolog.

Mol	Chain	Residues	Atoms					AltConf	Trace
			Total	C	N	O	S		
16	I	385	3022	1899	508	598	17	0	0

- Molecule 17 is a protein called 26S protease regulatory subunit 6B homolog.

Mol	Chain	Residues	Atoms					AltConf	Trace
			Total	C	N	O	S		
17	K	389	3078	1933	540	595	10	0	0

- Molecule 18 is a protein called 26S protease subunit RPT4.

Mol	Chain	Residues	Atoms					AltConf	Trace
			Total	C	N	O	S		
18	L	388	3082	1942	548	580	12	0	0

- Molecule 19 is a protein called 26S protease regulatory subunit 6A.

Mol	Chain	Residues	Atoms					AltConf	Trace
			Total	C	N	O	S		
19	M	381	2986	1870	524	580	12	0	0

- Molecule 20 is a protein called 26S protease regulatory subunit 8 homolog.

Mol	Chain	Residues	Atoms					AltConf	Trace
			Total	C	N	O	S		
20	J	386	3033	1906	543	567	17	0	0

- Molecule 21 is a protein called 26S proteasome regulatory subunit RPN10.

Mol	Chain	Residues	Atoms					AltConf	Trace
			Total	C	N	O	S		
21	W	197	1534	962	269	300	3	0	0

- Molecule 22 is a protein called Ubiquitin carboxyl-terminal hydrolase RPN11.

Mol	Chain	Residues	Atoms					AltConf	Trace
			Total	C	N	O	S		
22	V	289	2274	1425	389	446	14	0	0

- Molecule 23 is a protein called 26S proteasome regulatory subunit RPN12.

Mol	Chain	Residues	Atoms					AltConf	Trace
			Total	C	N	O	S		
23	T	266	2192	1405	349	432	6	0	0

- Molecule 24 is a protein called 26S proteasome regulatory subunit RPN13.

Mol	Chain	Residues	Atoms					AltConf	Trace
			Total	C	N	O	S		
24	X	127	1032	664	169	195	4	0	0

- Molecule 25 is a protein called 26S proteasome complex subunit SEM1.

Mol	Chain	Residues	Atoms				AltConf	Trace
			Total	C	N	O		
25	Y	51	435	264	69	102	0	0

- Molecule 26 is a protein called 26S proteasome regulatory subunit RPN1.

Mol	Chain	Residues	Atoms					AltConf	Trace
			Total	C	N	O	S		
26	Z	906	7005	4416	1150	1409	30	0	0

- Molecule 27 is a protein called 26S proteasome regulatory subunit RPN2.

Mol	Chain	Residues	Atoms					AltConf	Trace
			Total	C	N	O	S		
27	N	890	6882	4373	1156	1325	28	0	0

- Molecule 28 is a protein called 26S proteasome regulatory subunit RPN3.

Mol	Chain	Residues	Atoms					AltConf	Trace
			Total	C	N	O	S		
28	S	475	3894	2488	653	738	15	0	0

- Molecule 29 is a protein called 26S proteasome regulatory subunit RPN5.

Mol	Chain	Residues	Atoms					AltConf	Trace
			Total	C	N	O	S		
29	P	440	3608	2297	604	697	10	0	0

- Molecule 30 is a protein called 26S proteasome regulatory subunit RPN6.

Mol	Chain	Residues	Atoms					AltConf	Trace
			Total	C	N	O	S		
30	Q	434	3499	2225	577	681	16	0	0

- Molecule 31 is a protein called 26S proteasome regulatory subunit RPN7.

Mol	Chain	Residues	Atoms					AltConf	Trace
			Total	C	N	O	S		
31	R	381	3060	1955	502	593	10	0	0

- Molecule 32 is a protein called 26S proteasome regulatory subunit RPN8.

Mol	Chain	Residues	Atoms					AltConf	Trace
			Total	C	N	O	S		
32	U	298	2373	1496	404	466	7	0	0

- Molecule 33 is a protein called 26S proteasome regulatory subunit RPN9.

Mol	Chain	Residues	Atoms					AltConf	Trace
			Total	C	N	O	S		
33	O	388	3186	2051	519	608	8	0	0

- Molecule 34 is PHOSPHOAMINOPHOSPHONIC ACID-ADENYLATE ESTER (CCD ID: ANP) (formula: C₁₀H₁₇N₆O₁₂P₃).

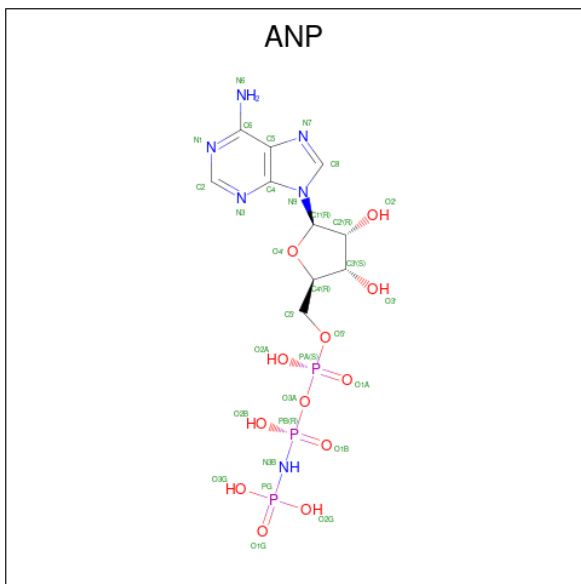

Mol	Chain	Residues	Atoms					AltConf
			Total	C	N	O	P	
34	H	1	31	10	6	12	3	0

Continued on next page...

Continued from previous page...

Mol	Chain	Residues	Atoms				AltConf	
34	I	1	Total	C	N	O	P	0
			31	10	6	12	3	
34	K	1	Total	C	N	O	P	0
			31	10	6	12	3	
34	L	1	Total	C	N	O	P	0
			31	10	6	12	3	
34	J	1	Total	C	N	O	P	0
			31	10	6	12	3	

- Molecule 35 is MAGNESIUM ION (CCD ID: MG) (formula: Mg).

Mol	Chain	Residues	Atoms		AltConf
35	H	1	Total	Mg	0
			1	1	
35	I	1	Total	Mg	0
			1	1	
35	K	1	Total	Mg	0
			1	1	
35	L	1	Total	Mg	0
			1	1	
35	M	1	Total	Mg	0
			1	1	
35	J	1	Total	Mg	0
			1	1	

- Molecule 36 is ADENOSINE-5'-DIPHOSPHATE (CCD ID: ADP) (formula: C₁₀H₁₅N₅O₁₀P₂).

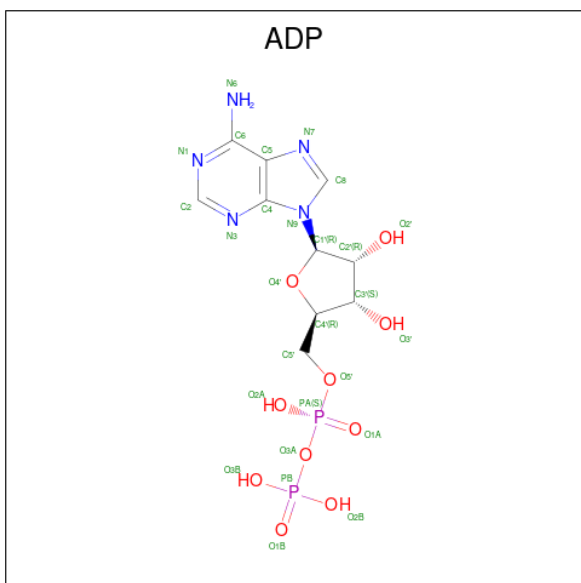

Mol	Chain	Residues	Atoms					AltConf
			Total	C	N	O	P	
36	M	1	27	10	5	10	2	0

3 Residue-property plots [i](#)

These plots are drawn for all protein, RNA, DNA and oligosaccharide chains in the entry. The first graphic for a chain summarises the proportions of the various outlier classes displayed in the second graphic. The second graphic shows the sequence view annotated by issues in geometry and atom inclusion in map density. Residues are color-coded according to the number of geometric quality criteria for which they contain at least one outlier: green = 0, yellow = 1, orange = 2 and red = 3 or more. A red diamond above a residue indicates a poor fit to the EM map for this residue (all-atom inclusion < 40%). Stretches of 2 or more consecutive residues without any outlier are shown as a green connector. Residues present in the sample, but not in the model, are shown in grey.

- Molecule 1: Proteasome subunit alpha type-1

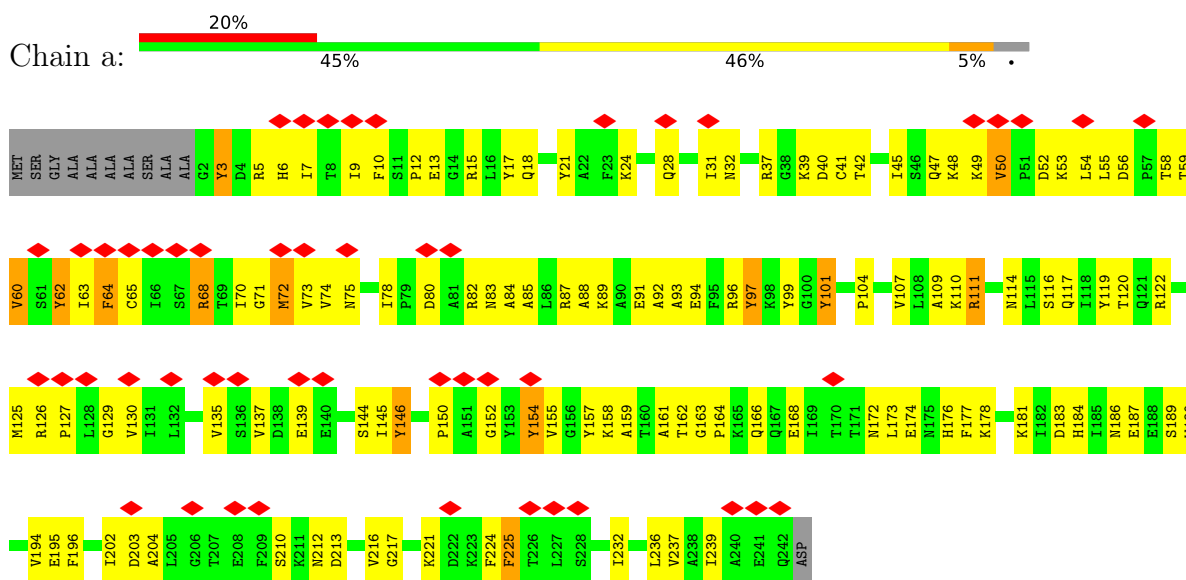

- Molecule 1: Proteasome subunit alpha type-1

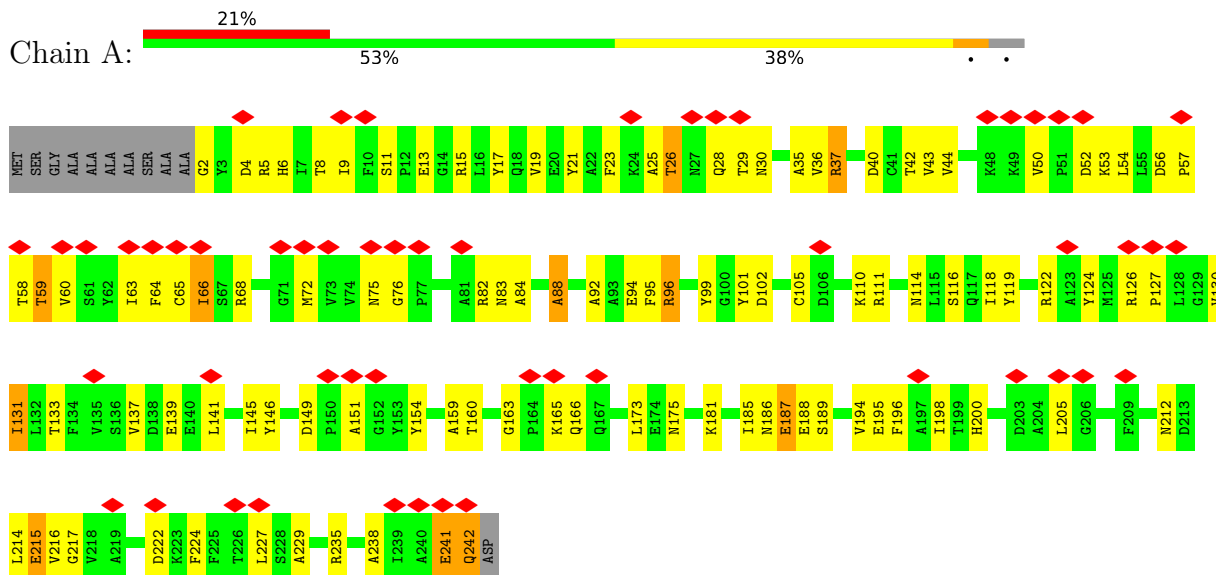

- Molecule 2: Proteasome subunit alpha type-2

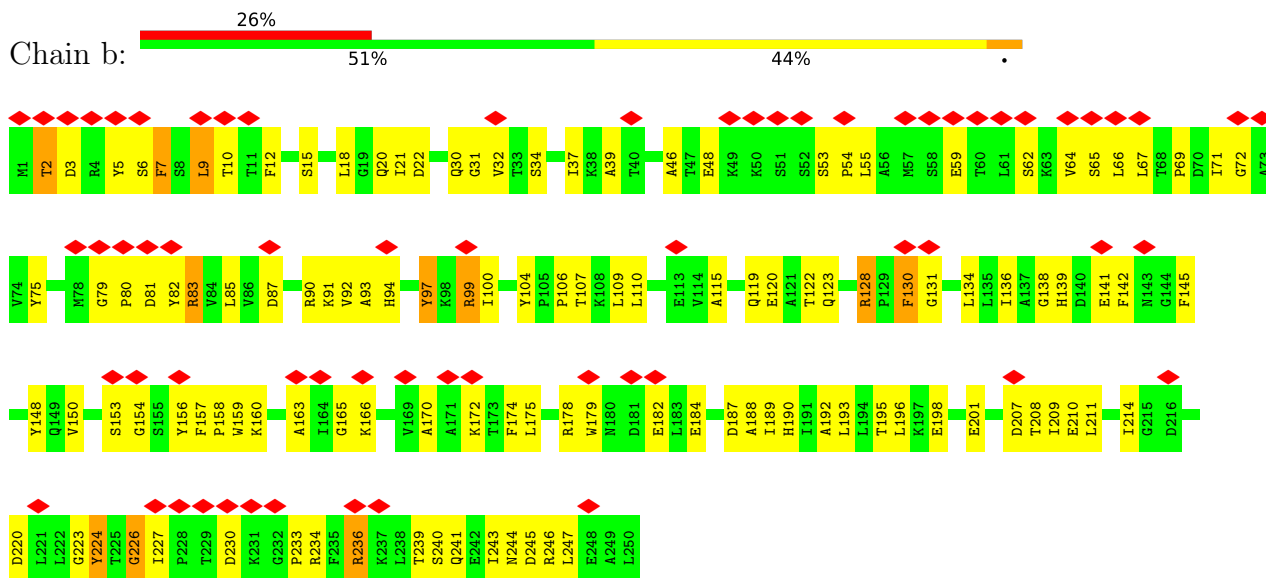

• Molecule 2: Proteasome subunit alpha type-2

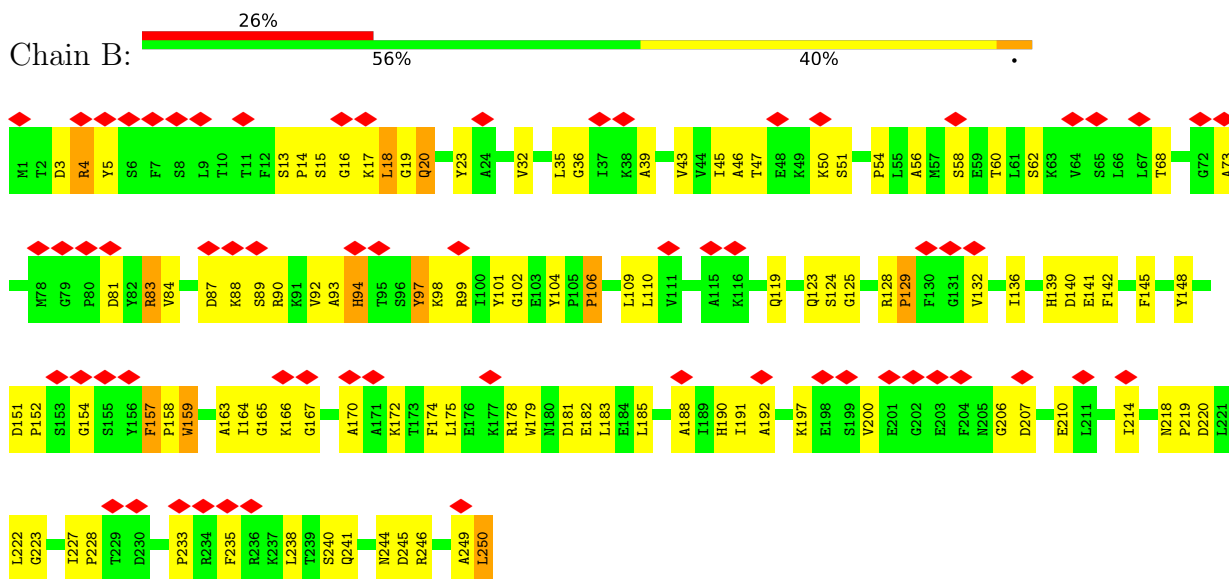

• Molecule 3: Proteasome subunit alpha type-3

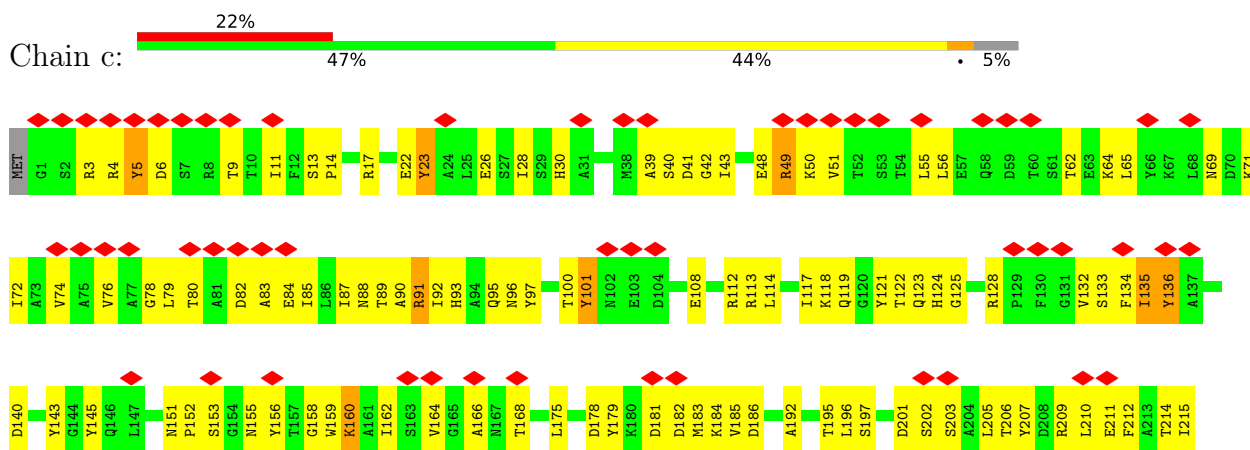



• Molecule 3: Proteasome subunit alpha type-3

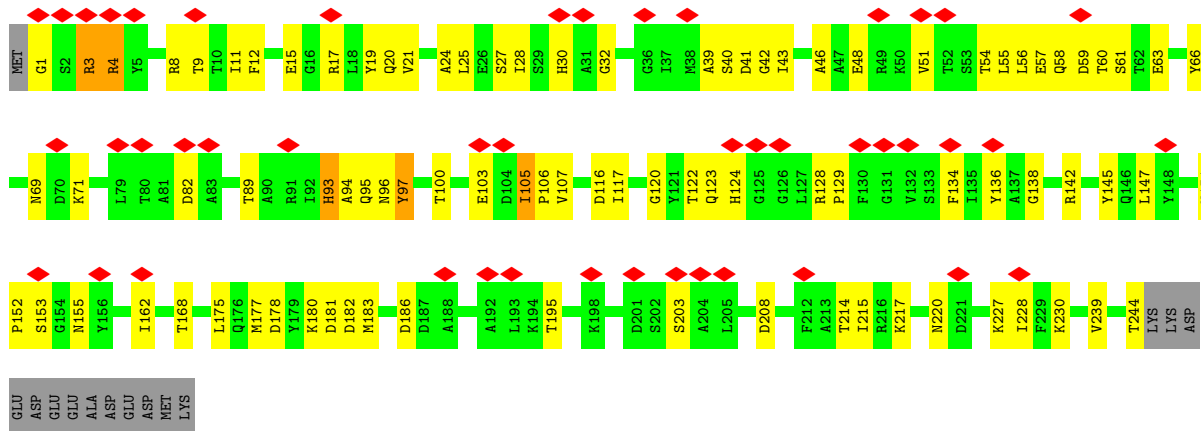

• Molecule 4: Proteasome subunit alpha type-4

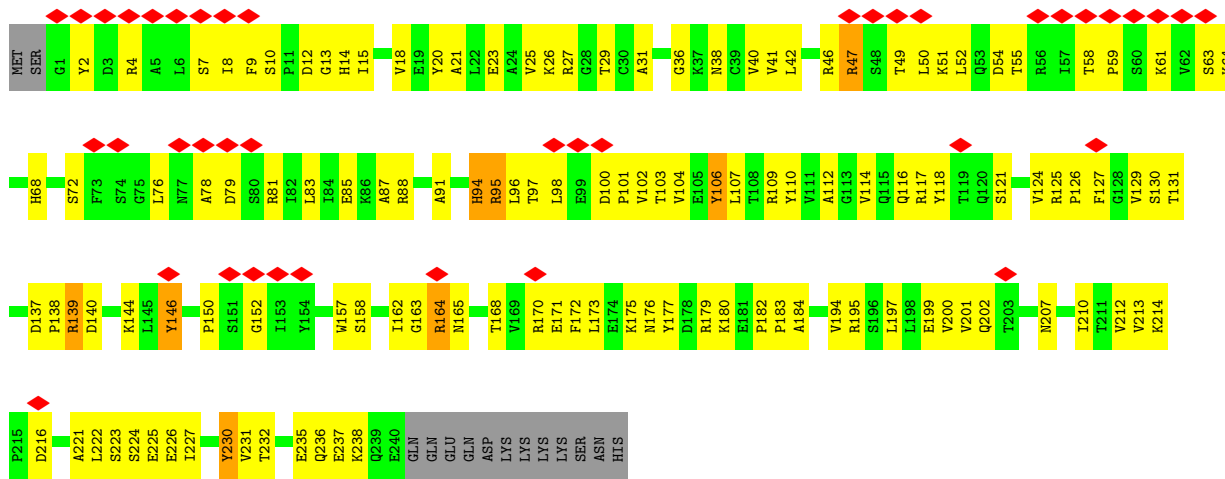
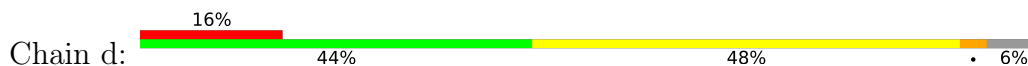

• Molecule 4: Proteasome subunit alpha type-4

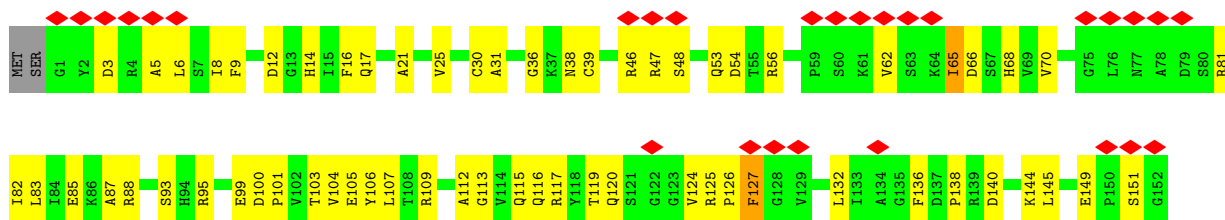

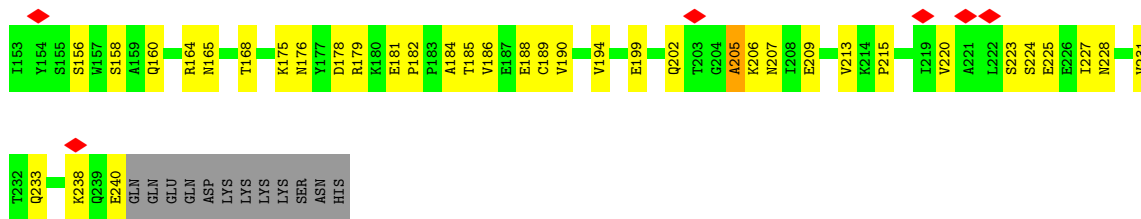

• Molecule 5: Proteasome subunit alpha type-5

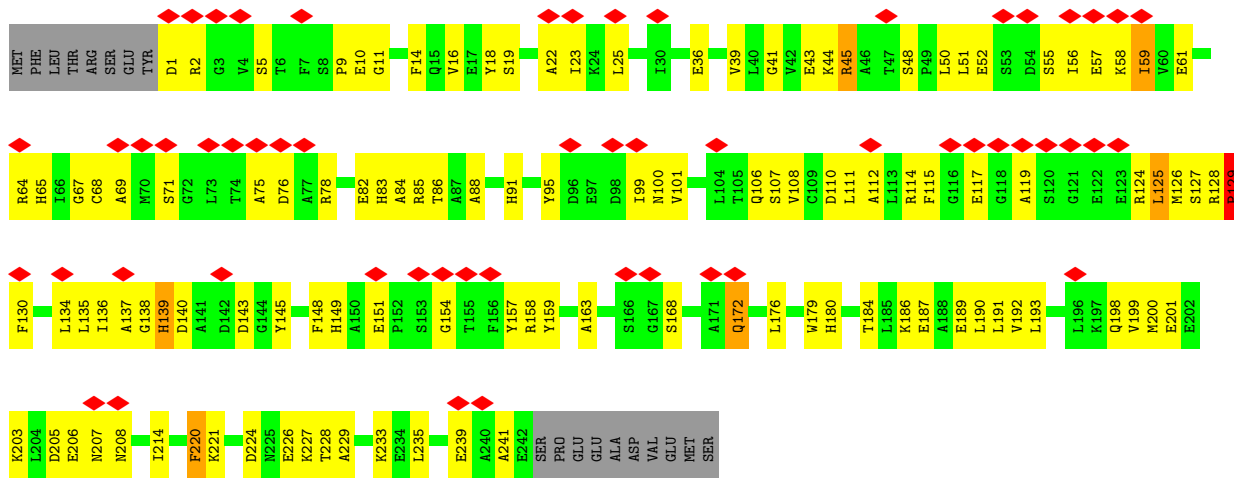

• Molecule 5: Proteasome subunit alpha type-5

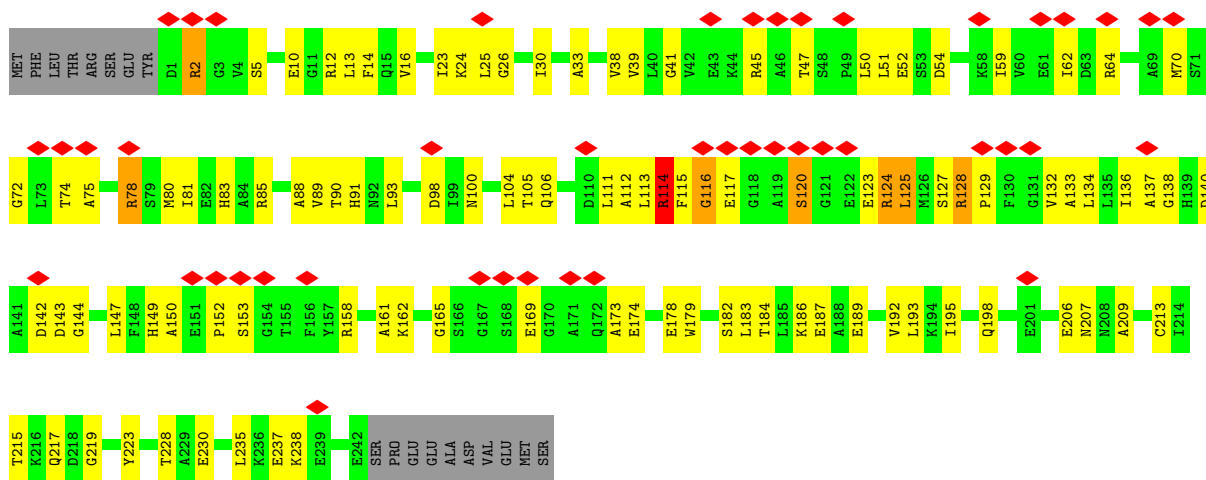

• Molecule 6: Proteasome subunit alpha type-6

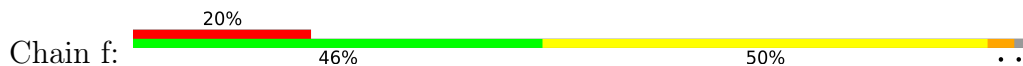

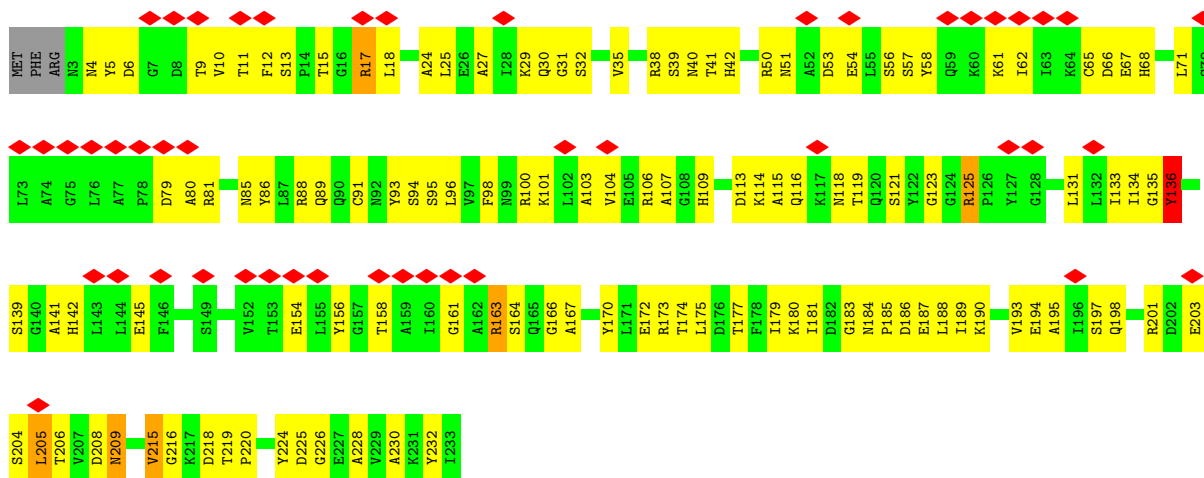

• Molecule 6: Proteasome subunit alpha type-6

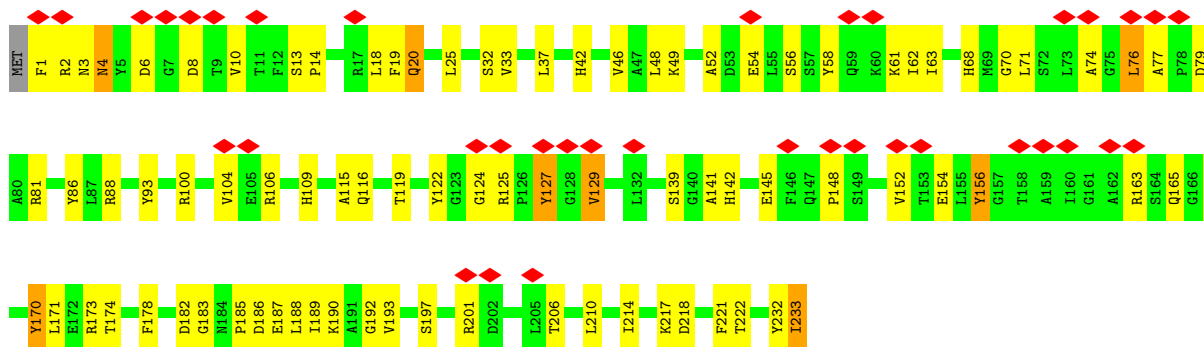

• Molecule 7: Probable proteasome subunit alpha type-7

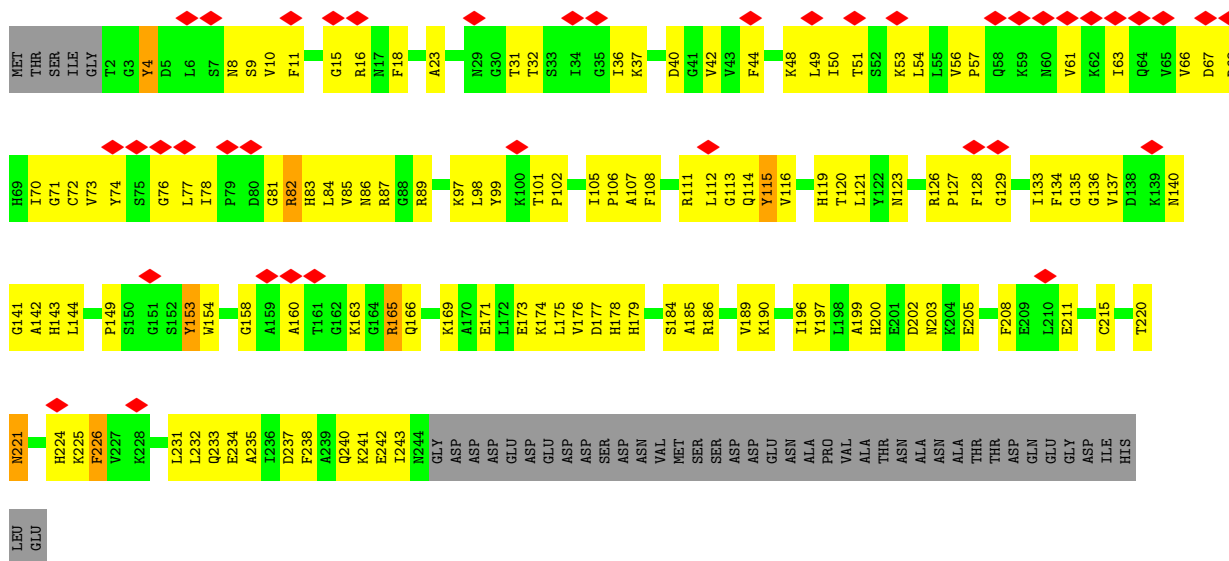

• Molecule 7: Probable proteasome subunit alpha type-7

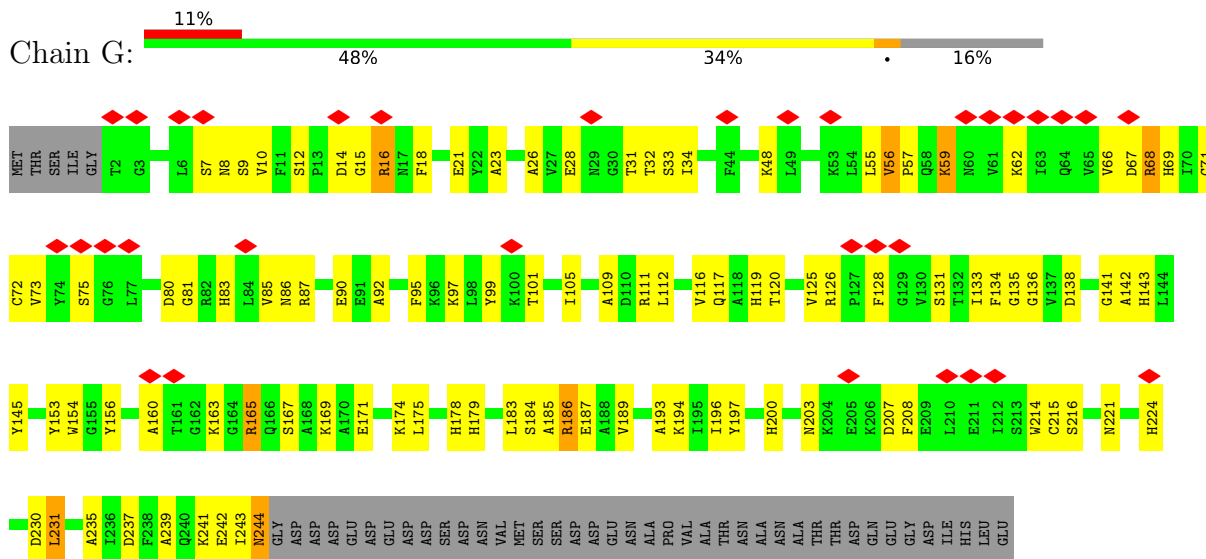

• Molecule 8: Proteasome subunit beta type-1

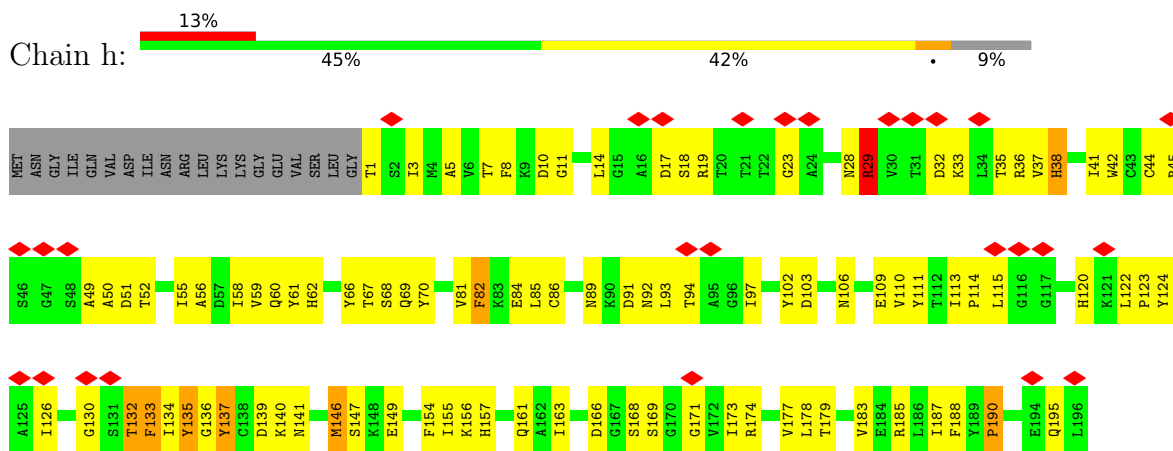

• Molecule 8: Proteasome subunit beta type-1

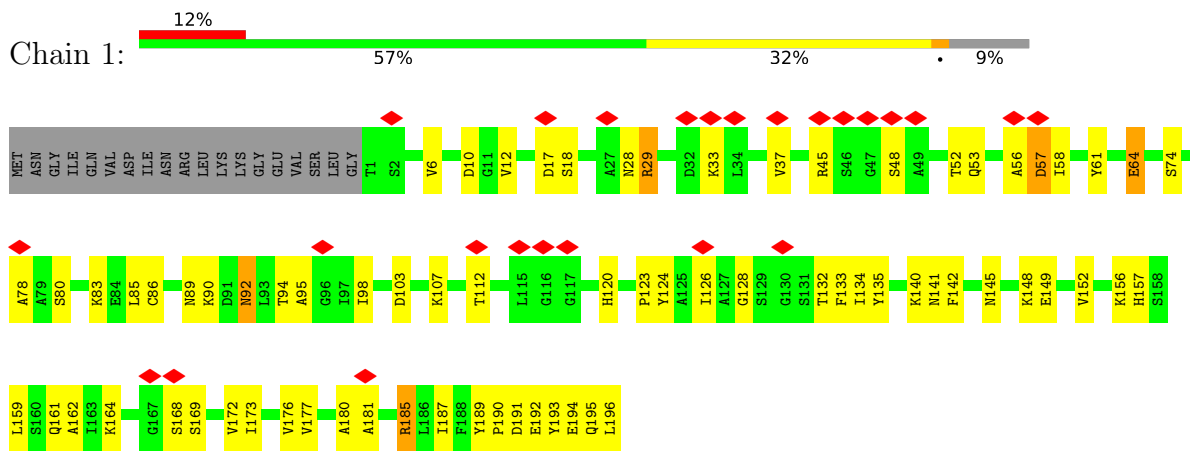

• Molecule 9: Proteasome subunit beta type-2

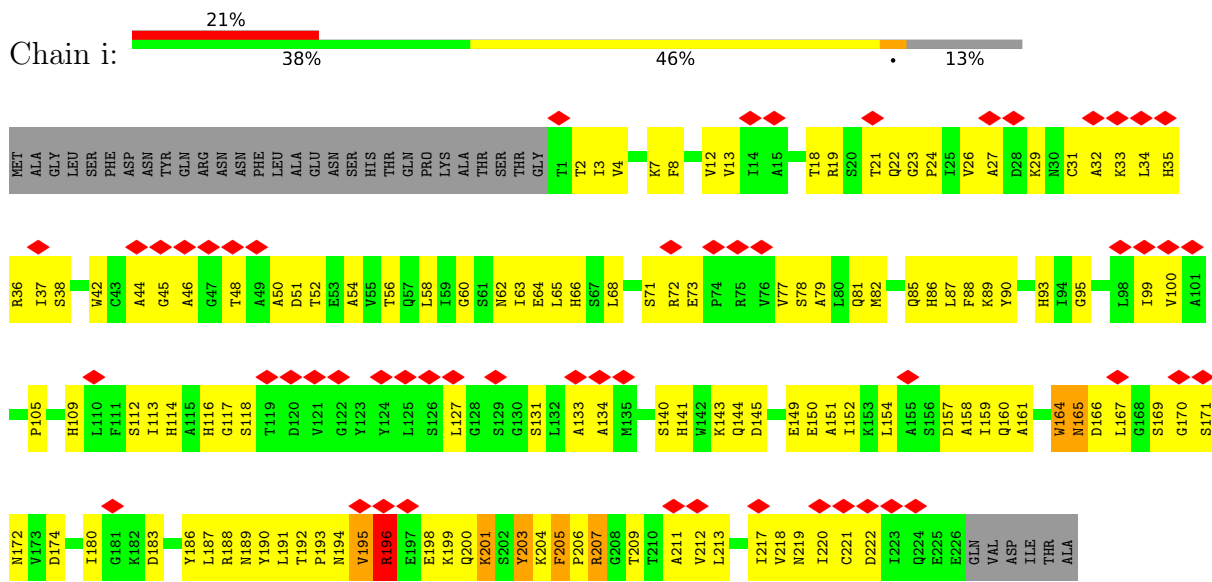

• Molecule 9: Proteasome subunit beta type-2

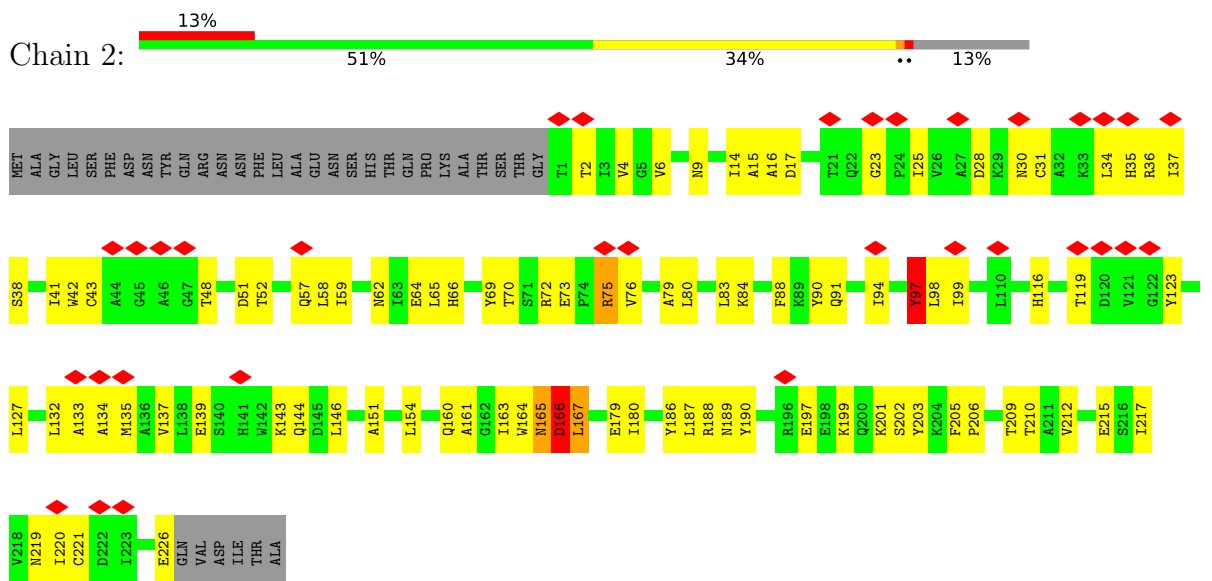

• Molecule 10: Proteasome subunit beta type-3

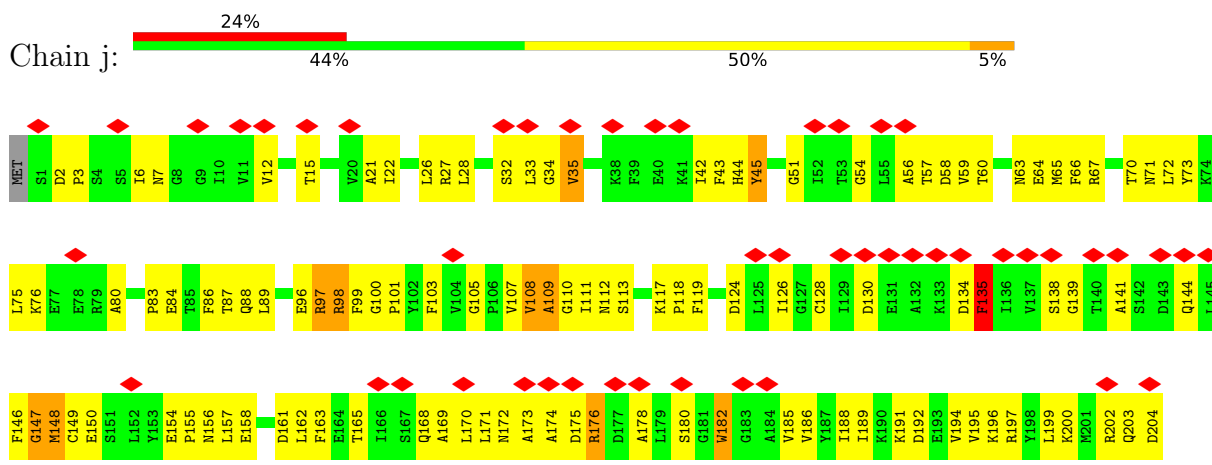

• Molecule 10: Proteasome subunit beta type-3

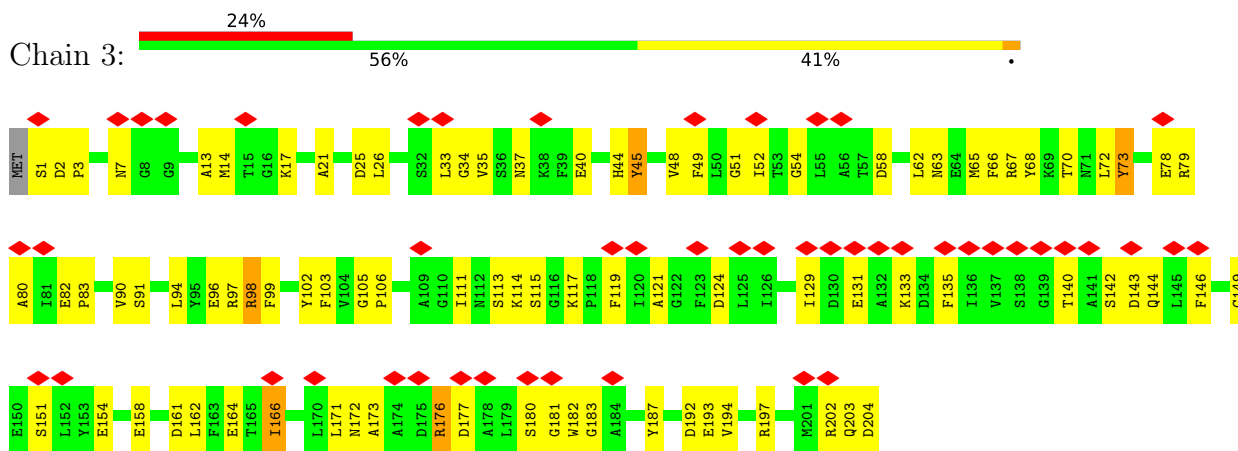

• Molecule 11: Proteasome subunit beta type-4

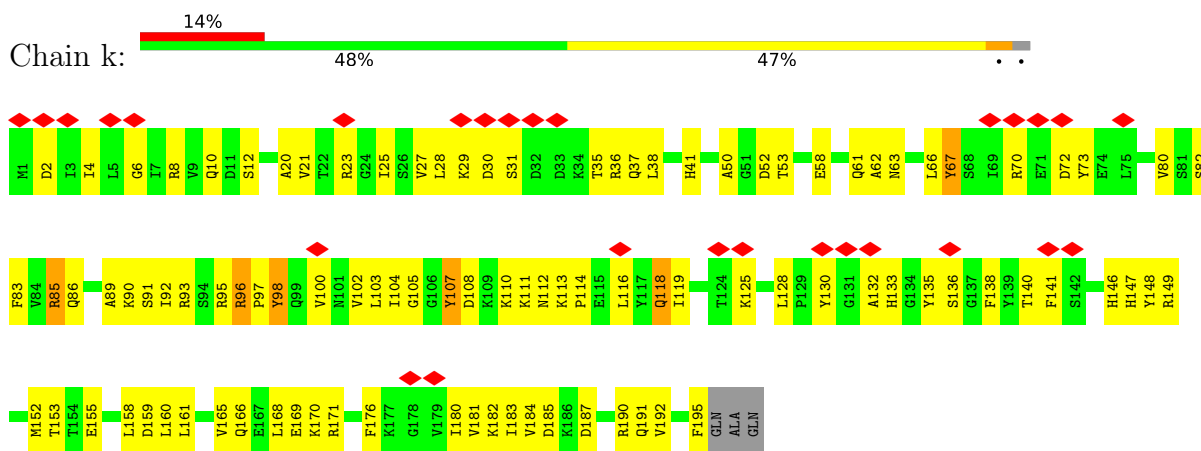

• Molecule 11: Proteasome subunit beta type-4

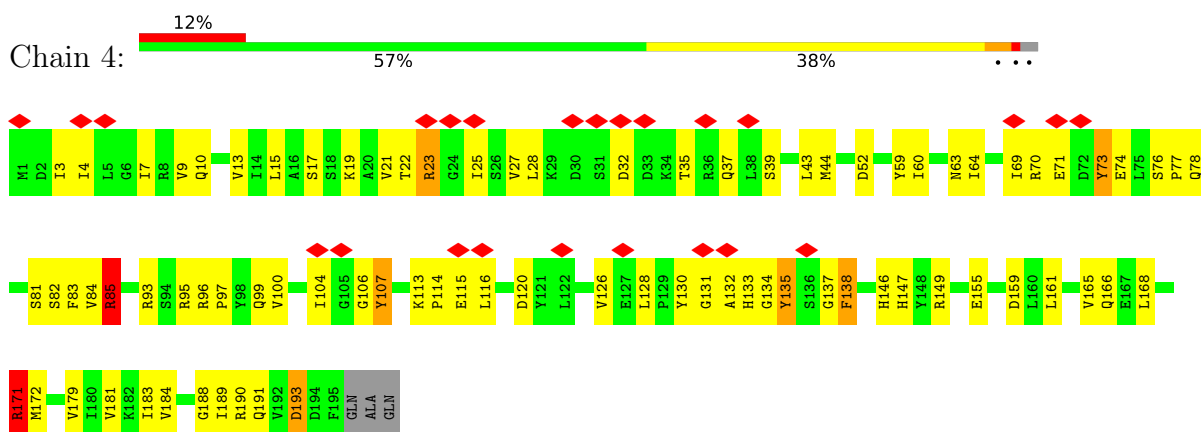

• Molecule 12: Proteasome subunit beta type-5

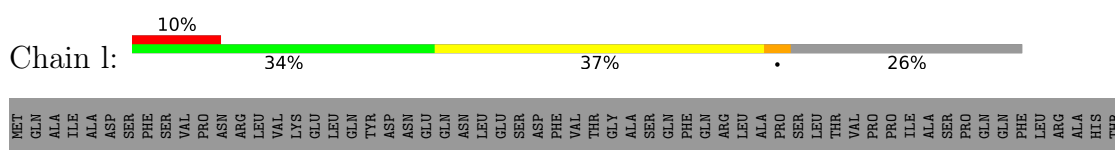

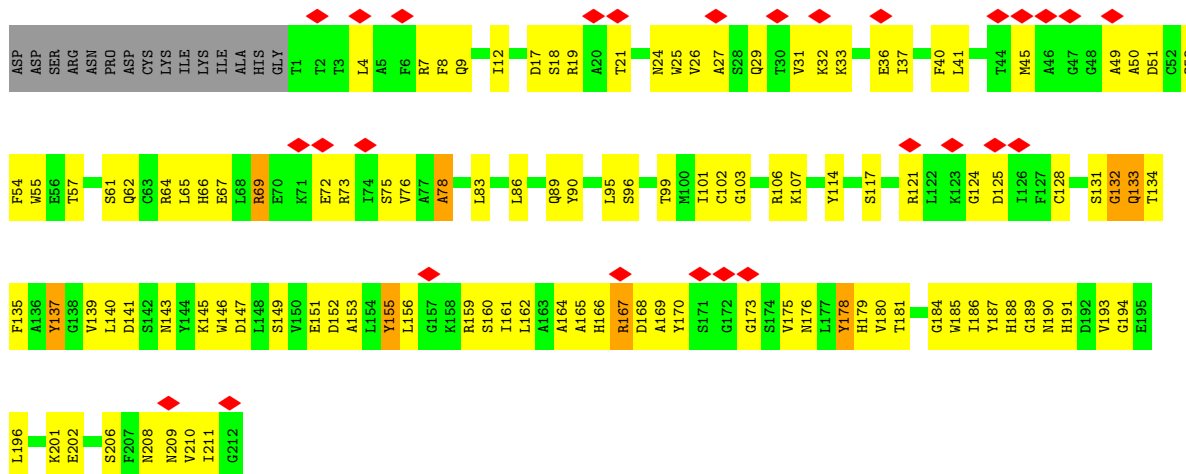

• Molecule 12: Proteasome subunit beta type-5

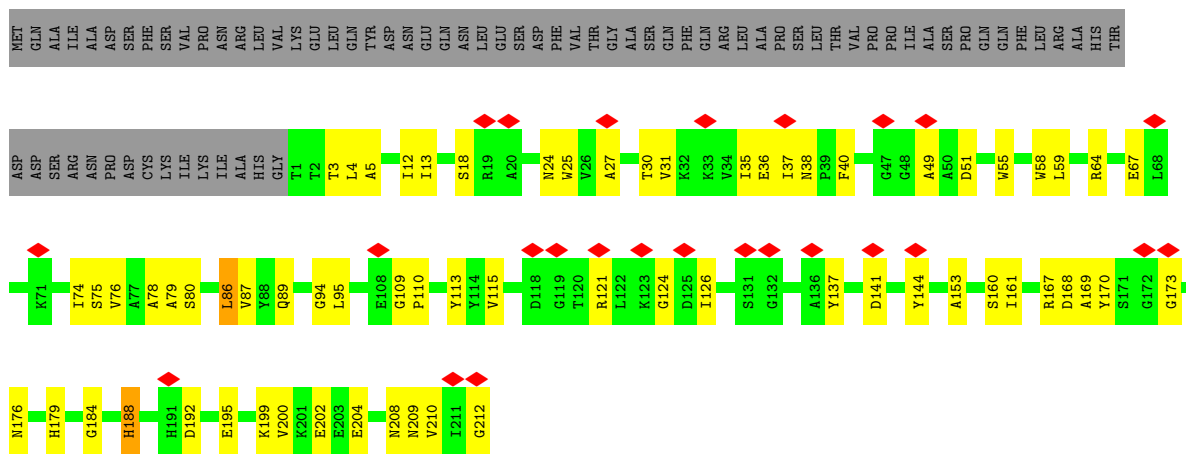

• Molecule 13: Proteasome subunit beta type-6

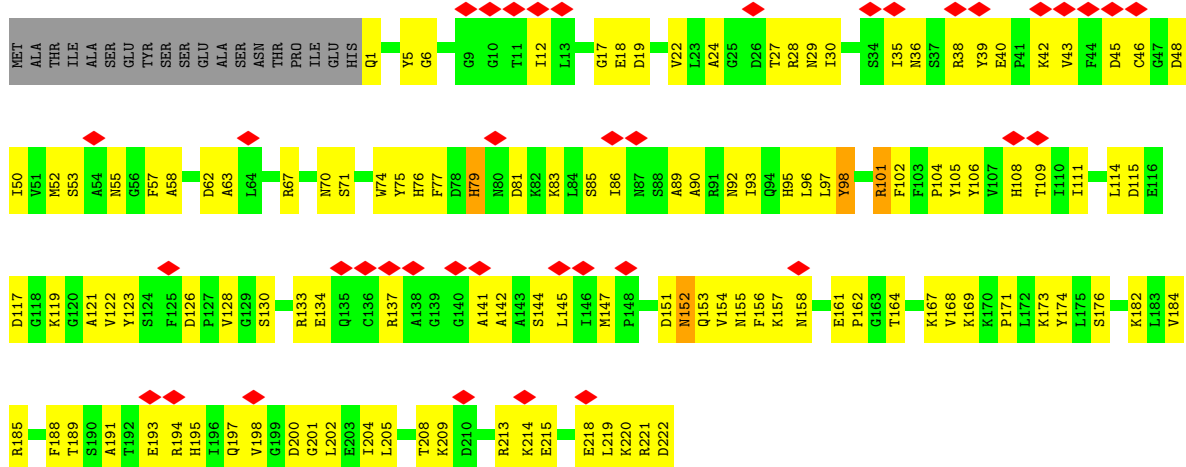

• Molecule 13: Proteasome subunit beta type-6

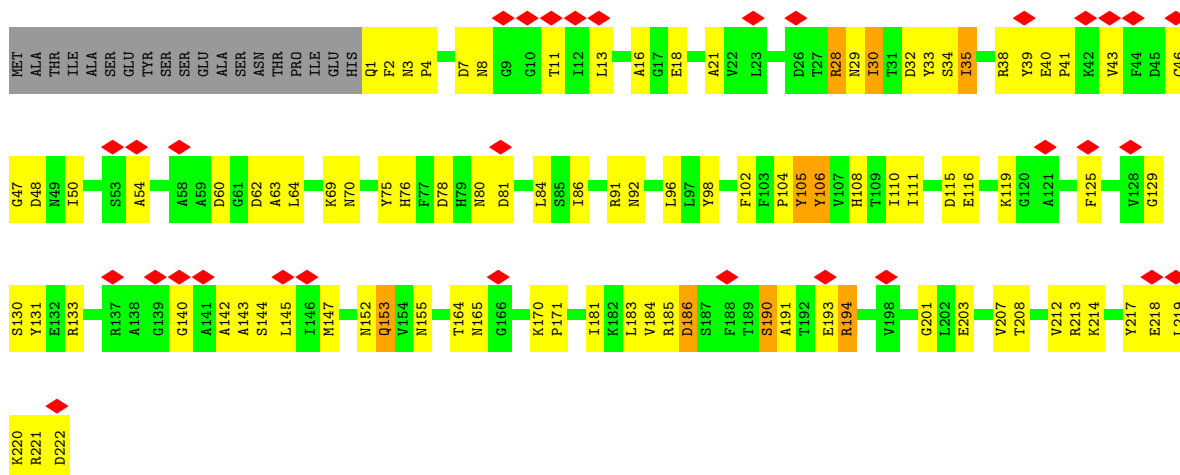

• Molecule 14: Proteasome subunit beta type-7

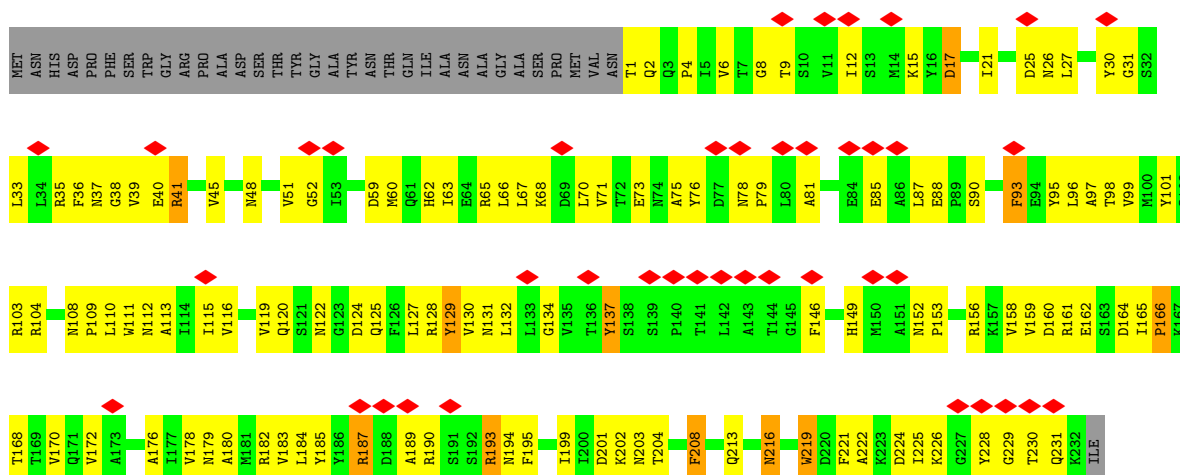

• Molecule 14: Proteasome subunit beta type-7

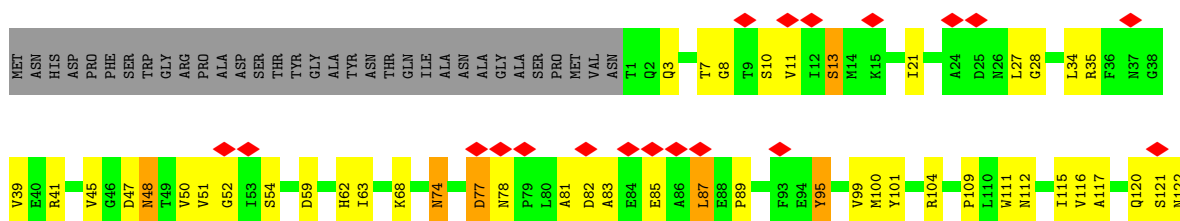

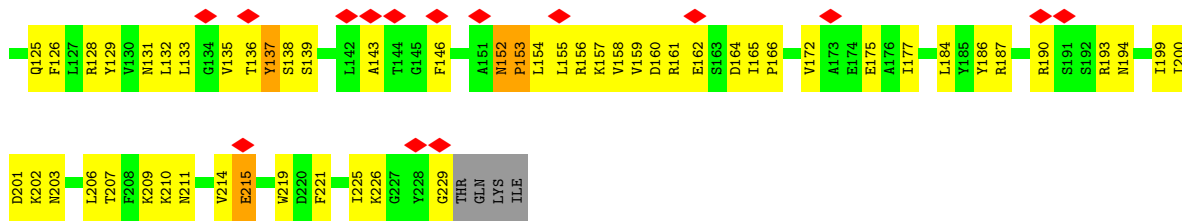

• Molecule 15: 26S protease regulatory subunit 7 homolog

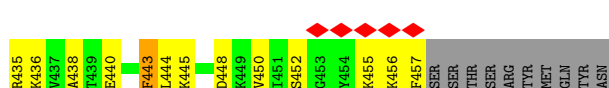
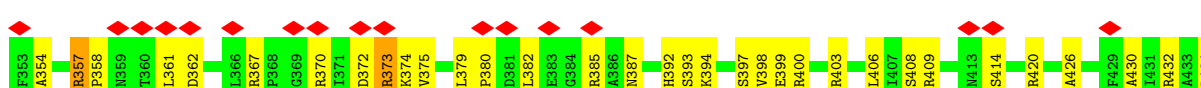
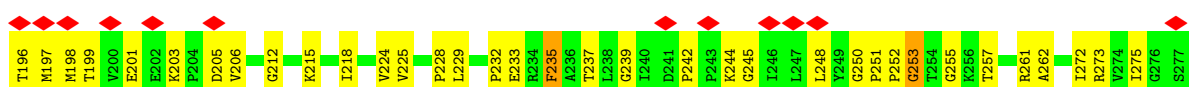
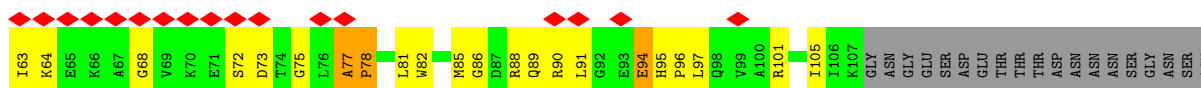
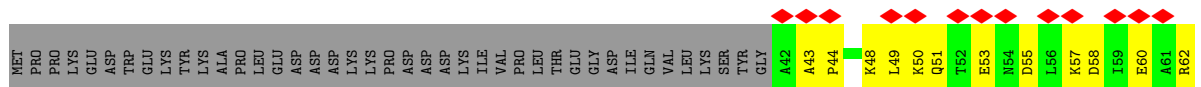

• Molecule 16: 26S protease regulatory subunit 4 homolog

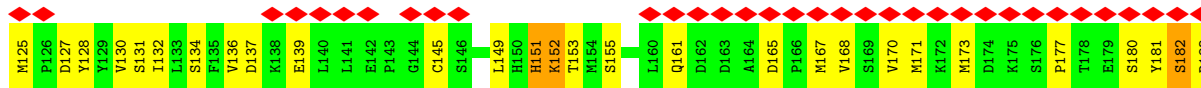
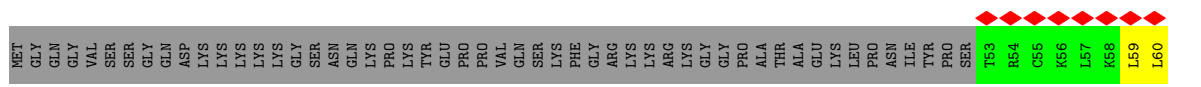
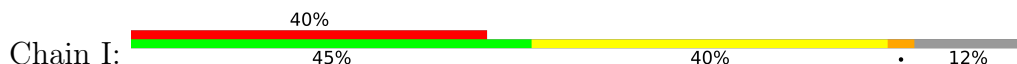

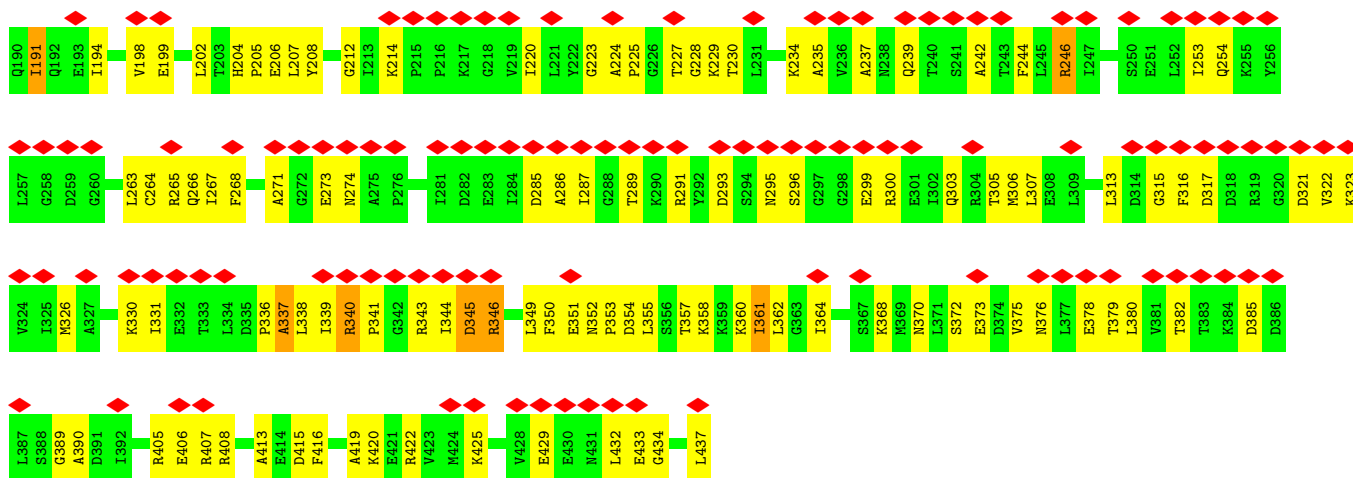

• Molecule 17: 26S protease regulatory subunit 6B homolog

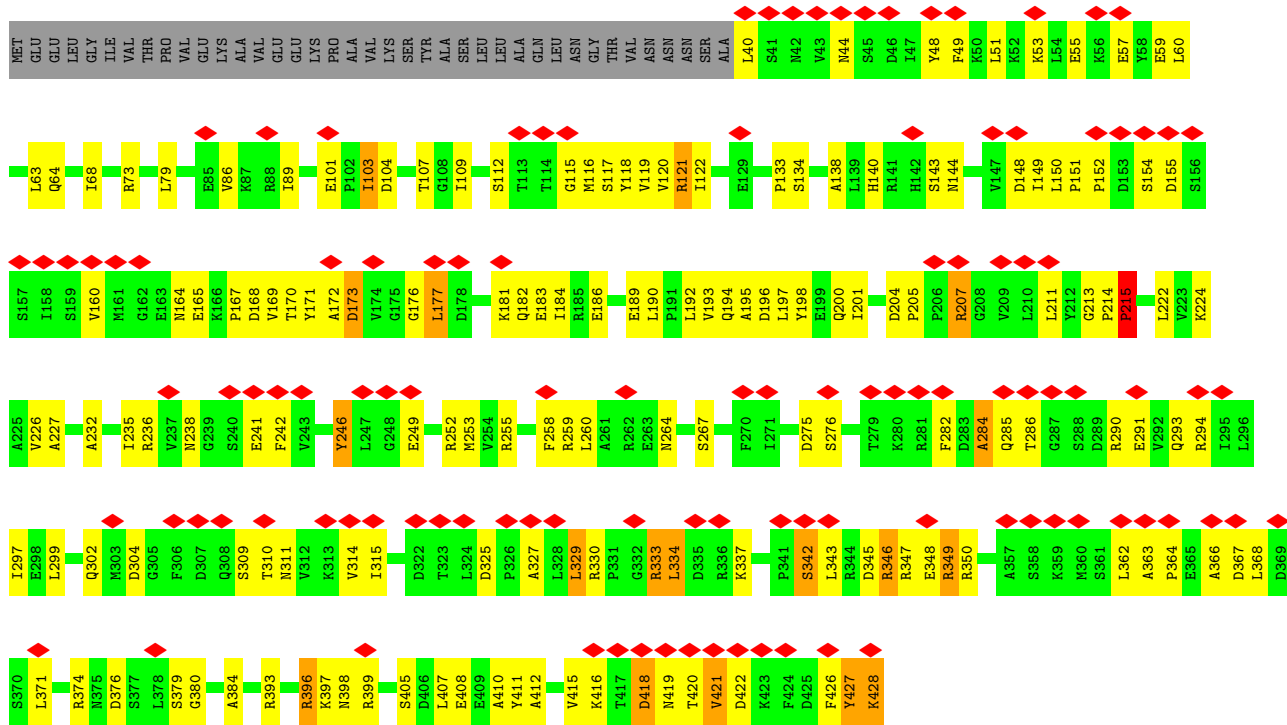

• Molecule 18: 26S protease subunit RPT4

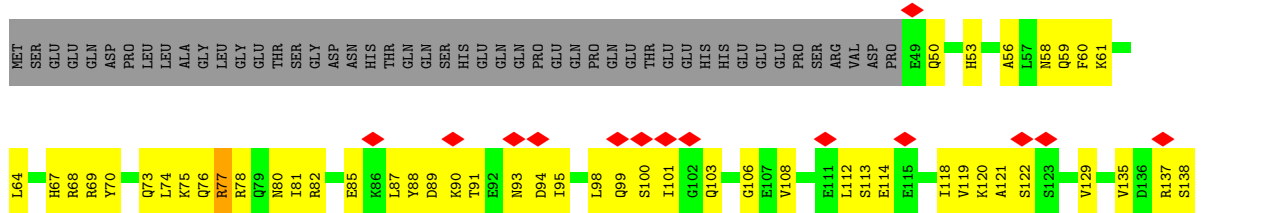

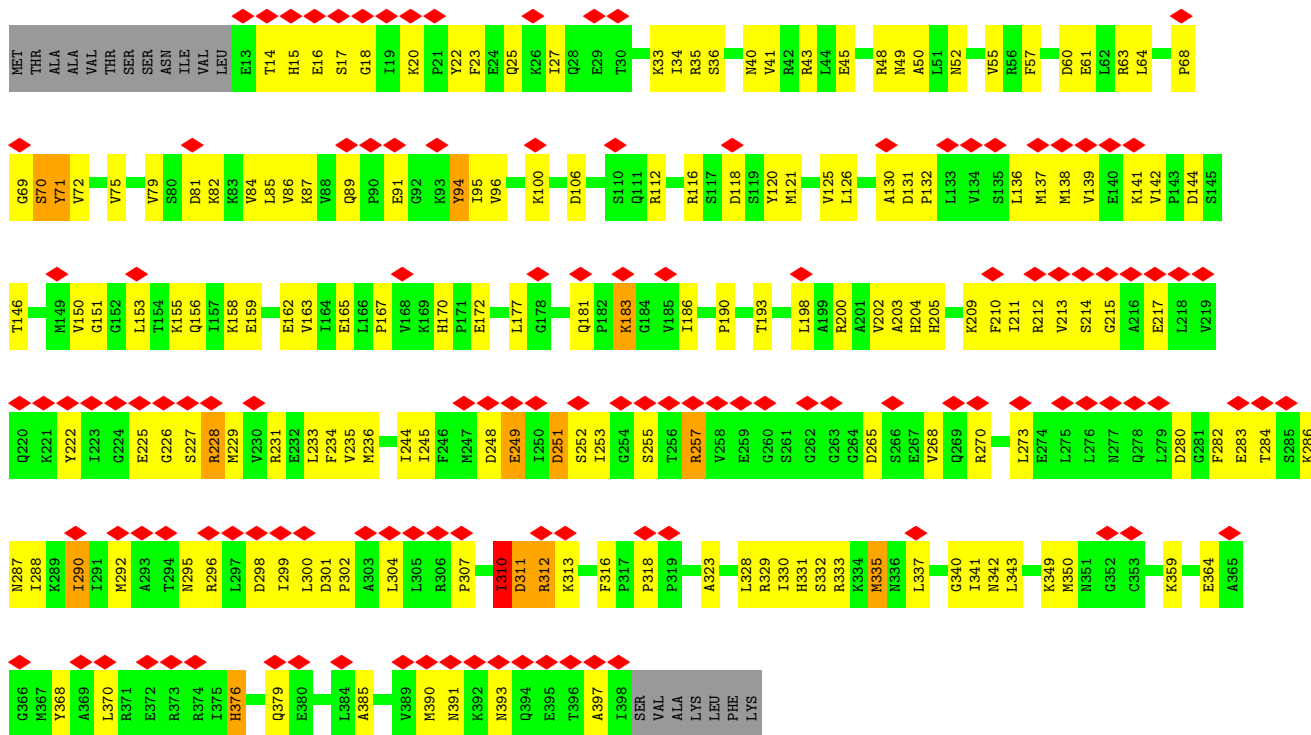

• Molecule 21: 26S proteasome regulatory subunit RPN10

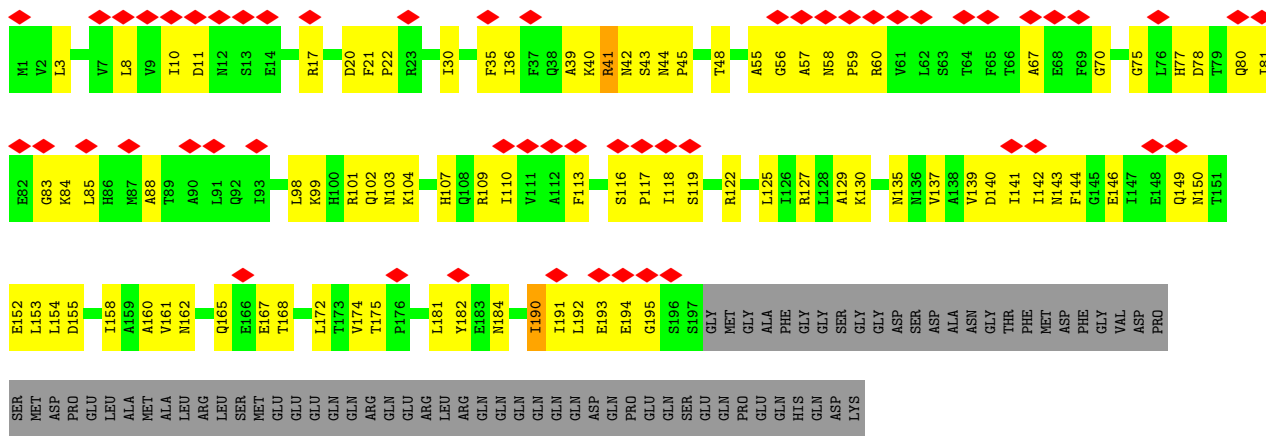

• Molecule 22: Ubiquitin carboxyl-terminal hydrolase RPN11

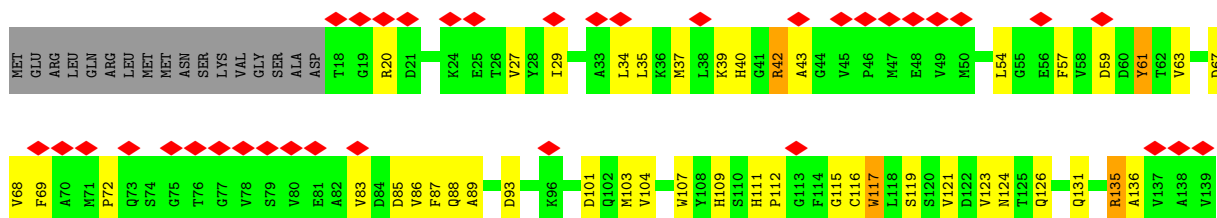

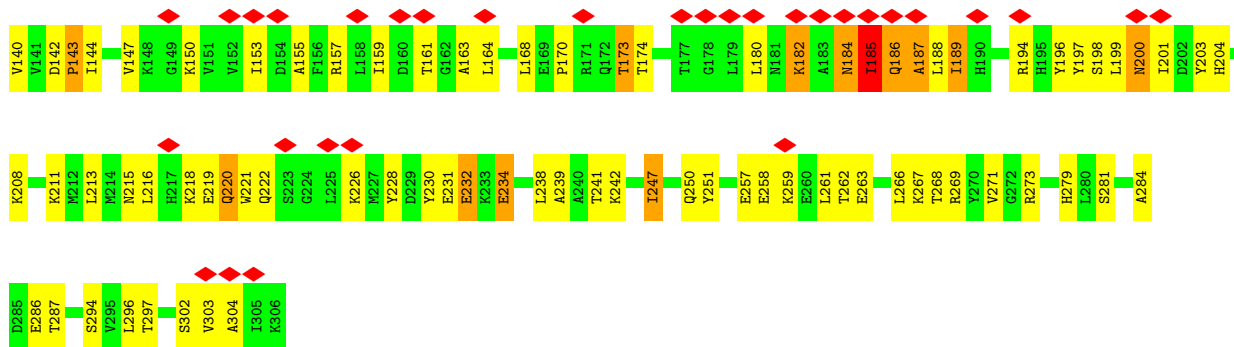

• Molecule 23: 26S proteasome regulatory subunit RPN12

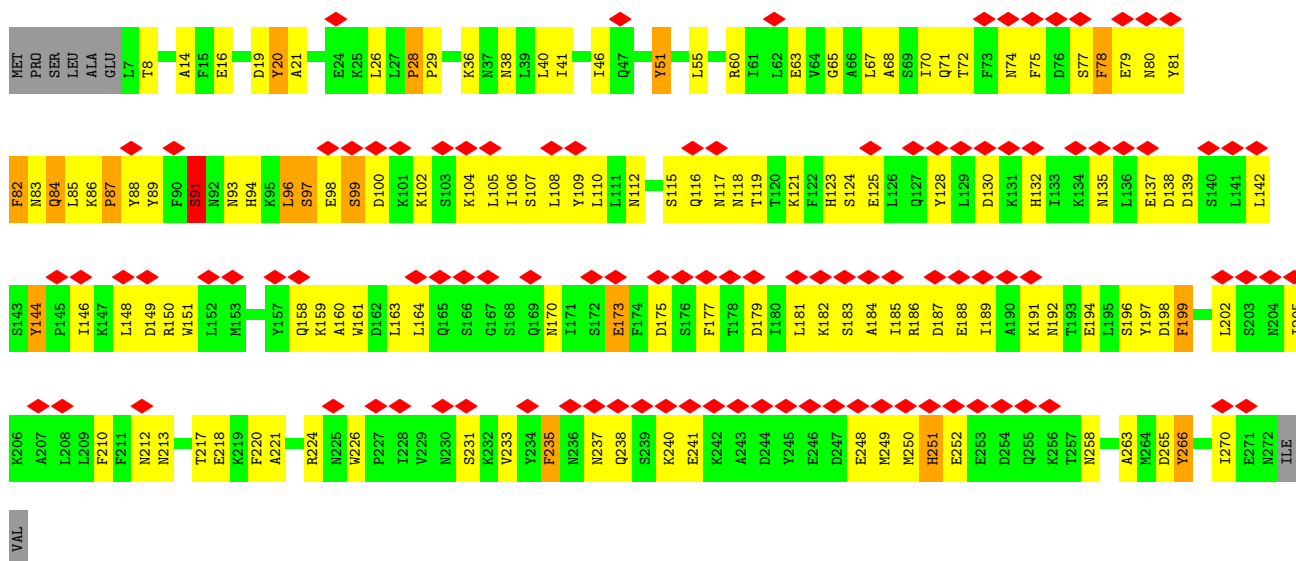
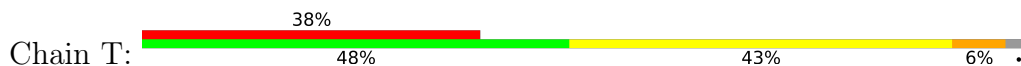

• Molecule 24: 26S proteasome regulatory subunit RPN13

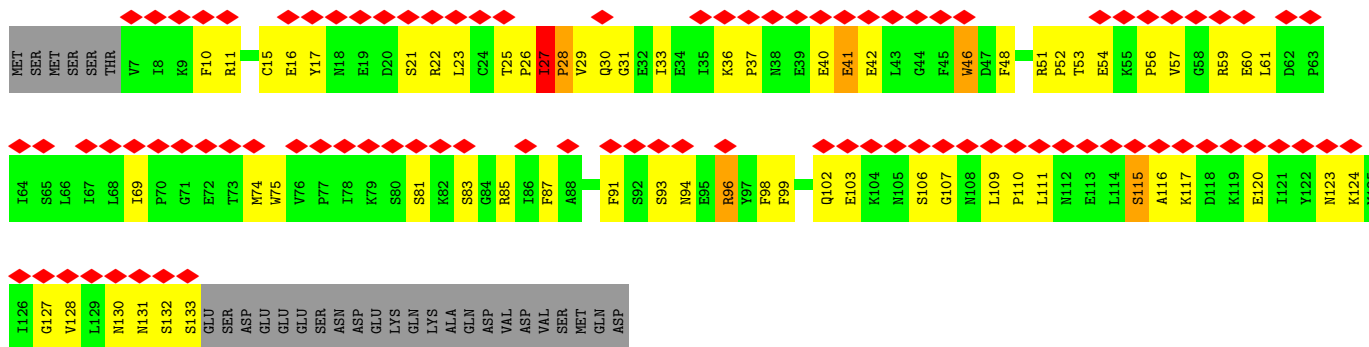
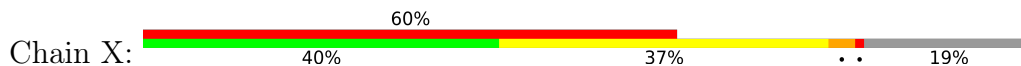

• Molecule 25: 26S proteasome complex subunit SEM1

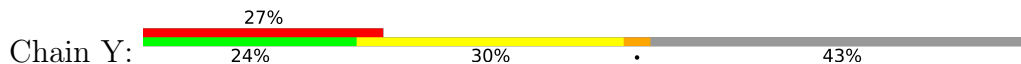

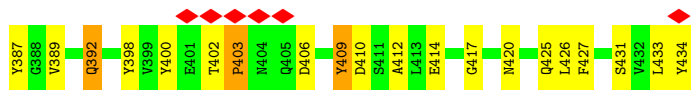

• Molecule 31: 26S proteasome regulatory subunit RPN7

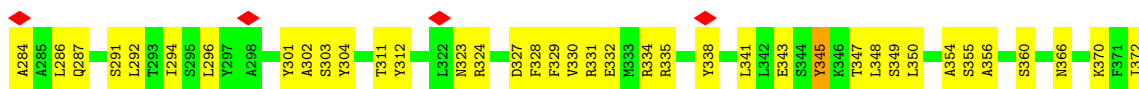
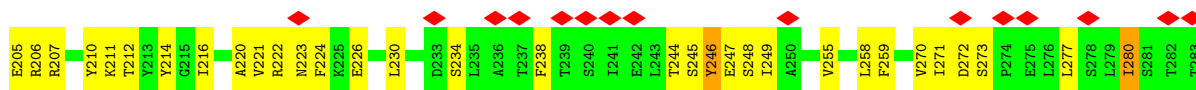
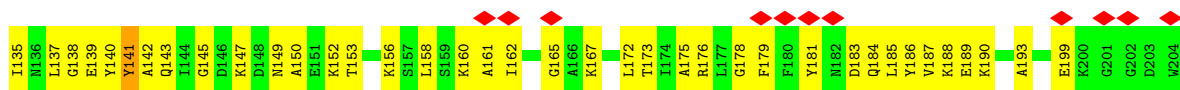
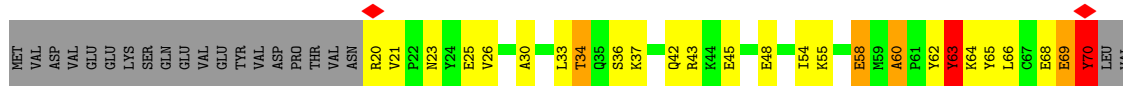

• Molecule 32: 26S proteasome regulatory subunit RPN8

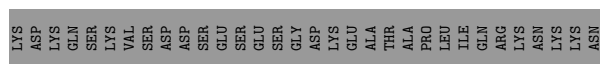
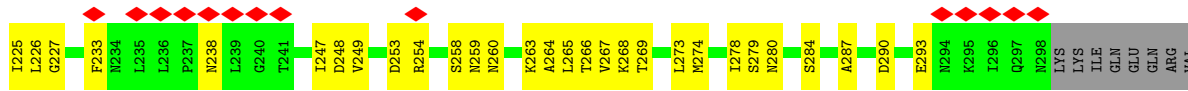
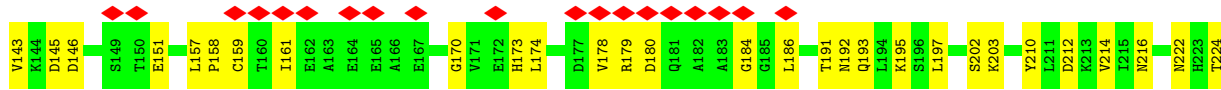
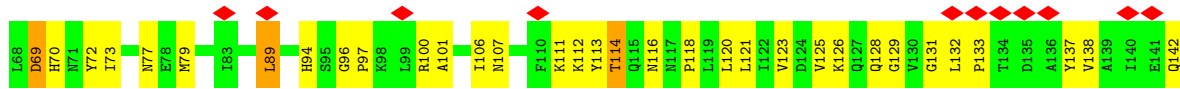
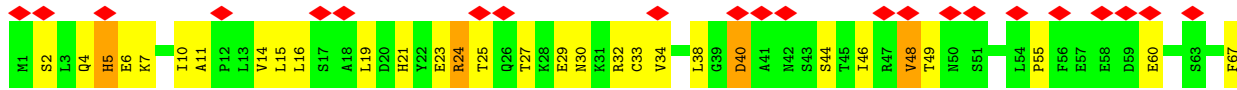

● Molecule 33: 26S proteasome regulatory subunit RPN9

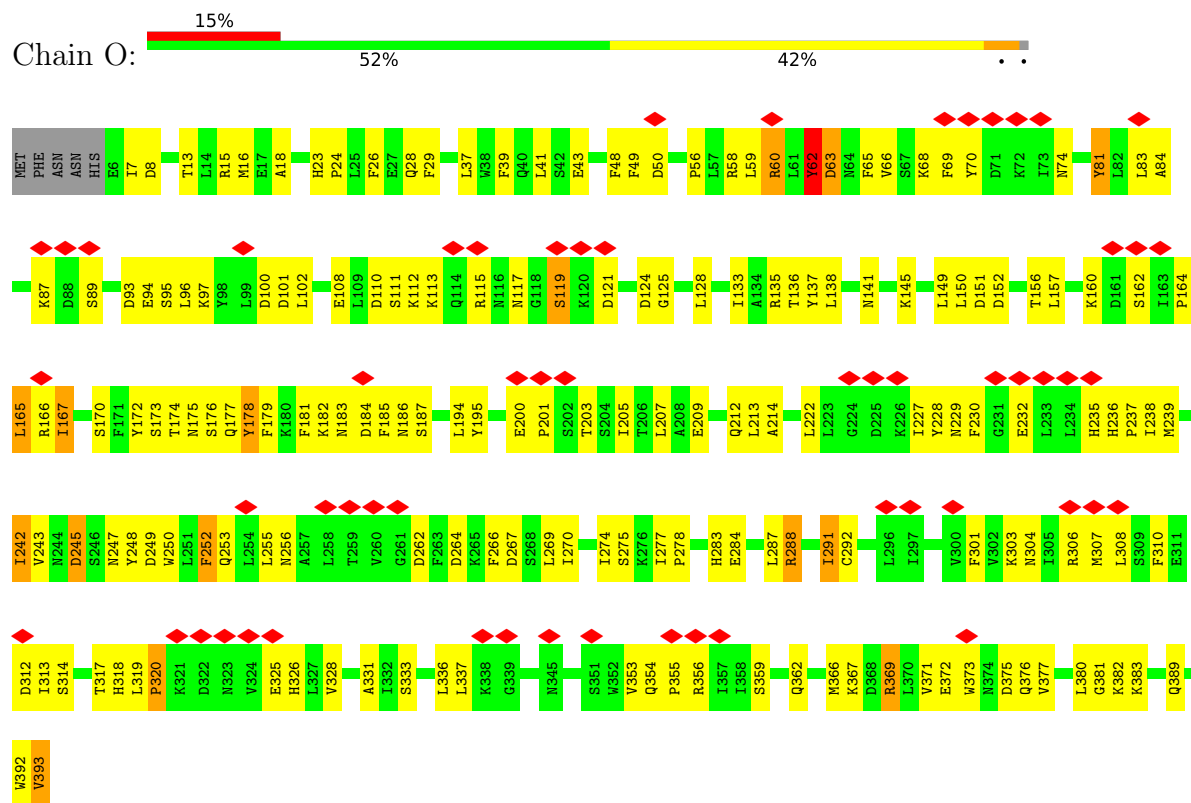

4 Experimental information

Property	Value	Source
EM reconstruction method	SINGLE PARTICLE	Depositor
Imposed symmetry	POINT, C1	Depositor
Number of particles used	67500	Depositor
Resolution determination method	FSC 0.143 CUT-OFF	Depositor
CTF correction method	PHASE FLIPPING AND AMPLITUDE CORRECTION	Depositor
Microscope	FEI TITAN KRIOS	Depositor
Voltage (kV)	300	Depositor
Electron dose ($e^-/\text{\AA}^2$)	45	Depositor
Minimum defocus (nm)	1500	Depositor
Maximum defocus (nm)	3500	Depositor
Magnification	Not provided	
Image detector	FEI FALCON II (4k x 4k)	Depositor
Maximum map value	0.113	Depositor
Minimum map value	-0.074	Depositor
Average map value	0.000	Depositor
Map value standard deviation	0.004	Depositor
Recommended contour level	0.019	Depositor
Map size (\AA)	561.60004, 561.60004, 561.60004	wwPDB
Map dimensions	416, 416, 416	wwPDB
Map angles ($^\circ$)	90.0, 90.0, 90.0	wwPDB
Pixel spacing (\AA)	1.3500001, 1.3500001, 1.3500001	Depositor

5 Model quality i

5.1 Standard geometry i

Bond lengths and bond angles in the following residue types are not validated in this section: MG, ADP, ANP

The Z score for a bond length (or angle) is the number of standard deviations the observed value is removed from the expected value. A bond length (or angle) with $|Z| > 5$ is considered an outlier worth inspection. RMSZ is the root-mean-square of all Z scores of the bond lengths (or angles).

Mol	Chain	Bond lengths		Bond angles	
		RMSZ	# $ Z > 5$	RMSZ	# $ Z > 5$
1	A	2.62	47/1945 (2.4%)	2.50	97/2634 (3.7%)
1	a	2.33	81/1945 (4.2%)	2.39	118/2634 (4.5%)
2	B	2.08	50/1952 (2.6%)	2.32	110/2642 (4.2%)
2	b	2.27	72/1952 (3.7%)	2.33	102/2642 (3.9%)
3	C	2.06	46/1934 (2.4%)	2.10	64/2618 (2.4%)
3	c	2.35	74/1934 (3.8%)	2.30	98/2618 (3.7%)
4	D	2.06	49/1910 (2.6%)	2.29	103/2586 (4.0%)
4	d	2.34	81/1910 (4.2%)	2.36	104/2586 (4.0%)
5	E	2.12	61/1886 (3.2%)	2.20	88/2541 (3.5%)
5	e	2.25	73/1886 (3.9%)	2.33	101/2541 (4.0%)
6	F	2.08	40/1823 (2.2%)	2.18	84/2463 (3.4%)
6	f	2.35	79/1800 (4.4%)	2.36	105/2433 (4.3%)
7	G	2.10	49/1932 (2.5%)	2.23	97/2609 (3.7%)
7	g	2.34	83/1932 (4.3%)	2.39	112/2609 (4.3%)
8	1	1.99	27/1541 (1.8%)	2.03	56/2087 (2.7%)
8	h	2.29	63/1541 (4.1%)	2.30	65/2087 (3.1%)
9	2	2.04	42/1750 (2.4%)	2.14	74/2373 (3.1%)
9	i	2.37	88/1750 (5.0%)	2.45	126/2373 (5.3%)
10	3	2.07	44/1611 (2.7%)	2.21	81/2174 (3.7%)
10	j	2.33	74/1611 (4.6%)	2.33	91/2174 (4.2%)
11	4	2.04	40/1589 (2.5%)	2.10	78/2142 (3.6%)
11	k	2.38	73/1589 (4.6%)	2.38	89/2142 (4.2%)
12	5	2.02	29/1681 (1.7%)	2.03	44/2274 (1.9%)
12	l	2.35	80/1681 (4.8%)	2.39	93/2274 (4.1%)
13	6	2.13	50/1795 (2.8%)	2.11	68/2420 (2.8%)
13	m	2.31	74/1795 (4.1%)	2.35	88/2420 (3.6%)
14	7	2.09	50/1821 (2.7%)	2.10	72/2470 (2.9%)
14	n	2.35	79/1846 (4.3%)	2.32	106/2503 (4.2%)
15	H	2.10	94/3014 (3.1%)	2.28	154/4058 (3.8%)
16	I	2.21	101/3061 (3.3%)	2.37	172/4121 (4.2%)
17	K	2.08	85/3121 (2.7%)	2.21	161/4213 (3.8%)
18	L	2.09	93/3128 (3.0%)	2.20	150/4204 (3.6%)

Mol	Chain	Bond lengths		Bond angles	
		RMSZ	# Z >5	RMSZ	# Z >5
19	M	2.15	83/3023 (2.7%)	2.28	166/4070 (4.1%)
20	J	2.08	89/3073 (2.9%)	2.27	161/4129 (3.9%)
21	W	2.12	44/1557 (2.8%)	2.22	87/2111 (4.1%)
22	V	2.17	58/2309 (2.5%)	2.26	112/3115 (3.6%)
23	T	2.10	69/2235 (3.1%)	2.38	141/3017 (4.7%)
24	X	2.22	32/1058 (3.0%)	2.28	56/1432 (3.9%)
25	Y	2.23	16/438 (3.7%)	2.24	24/583 (4.1%)
26	Z	2.13	214/7122 (3.0%)	2.33	415/9645 (4.3%)
27	N	2.12	242/6994 (3.5%)	2.30	403/9455 (4.3%)
28	S	2.02	117/3966 (3.0%)	2.31	220/5355 (4.1%)
29	P	1.97	73/3663 (2.0%)	2.31	214/4940 (4.3%)
30	Q	2.03	95/3556 (2.7%)	2.27	176/4787 (3.7%)
31	R	2.10	76/3110 (2.4%)	2.40	207/4193 (4.9%)
32	U	2.02	63/2407 (2.6%)	2.13	97/3258 (3.0%)
33	O	2.13	91/3247 (2.8%)	2.35	188/4380 (4.3%)
All	All	2.16	3433/110424 (3.1%)	2.29	5818/149135 (3.9%)

Chiral center outliers are detected by calculating the chiral volume of a chiral center and verifying if the center is modelled as a planar moiety or with the opposite hand. A planarity outlier is detected by checking planarity of atoms in a peptide group, atoms in a mainchain group or atoms of a sidechain that are expected to be planar.

Mol	Chain	#Chirality outliers	#Planarity outliers
1	A	0	8
1	a	0	10
2	B	0	6
2	b	0	9
3	C	0	4
3	c	0	10
4	D	0	2
4	d	0	9
5	E	0	4
5	e	0	7
6	F	0	5
6	f	0	5
7	G	0	4
7	g	0	9
8	1	0	2
8	h	0	5
9	2	0	4
9	i	0	3
10	3	0	4

Continued on next page...

Continued from previous page...

Mol	Chain	#Chirality outliers	#Planarity outliers
10	j	0	5
11	4	0	6
11	k	0	5
12	5	0	2
12	l	0	7
13	6	0	6
13	m	0	6
14	7	0	4
14	n	0	5
15	H	0	7
16	I	0	7
17	K	0	12
18	L	0	10
19	M	0	14
20	J	0	8
21	W	0	1
22	V	0	3
23	T	0	12
24	X	0	2
25	Y	0	2
26	Z	0	13
27	N	0	13
28	S	0	7
29	P	0	8
30	Q	0	9
31	R	0	16
32	U	0	2
33	O	0	6
All	All	0	308

The worst 5 of 3433 bond length outliers are listed below:

Mol	Chain	Res	Type	Atoms	Z	Observed(Å)	Ideal(Å)
1	A	242	GLN	CA-C	70.47	3.00	1.52
22	V	186	GLN	CA-CB	22.83	1.95	1.52
1	A	242	GLN	N-CA	-16.99	1.14	1.46
22	V	187	ALA	N-CA	-16.16	1.26	1.46
6	F	4	ASN	CA-CB	-16.14	1.26	1.53

The worst 5 of 5818 bond angle outliers are listed below:

Mol	Chain	Res	Type	Atoms	Z	Observed(°)	Ideal(°)
1	A	241	GLU	CA-C-N	-36.37	56.24	121.70
1	A	241	GLU	C-N-CA	-36.37	56.24	121.70
22	V	187	ALA	N-CA-C	21.27	136.63	111.11
27	N	859	ASN	CB-CA-C	-20.86	80.12	110.16
22	V	186	GLN	N-CA-CB	-18.27	65.38	111.04

There are no chirality outliers.

5 of 308 planarity outliers are listed below:

Mol	Chain	Res	Type	Group
1	a	3	TYR	Sidechain
1	a	62	TYR	Sidechain
1	a	68	ARG	Sidechain
1	a	97	TYR	Sidechain
1	a	99	TYR	Sidechain

5.2 Too-close contacts [i](#)

In the following table, the Non-H and H(model) columns list the number of non-hydrogen atoms and hydrogen atoms in the chain respectively. The H(added) column lists the number of hydrogen atoms added and optimized by MolProbity. The Clashes column lists the number of clashes within the asymmetric unit, whereas Symm-Clashes lists symmetry-related clashes.

Mol	Chain	Non-H	H(model)	H(added)	Clashes	Symm-Clashes
1	A	1907	0	1901	18	0
1	a	1907	0	1901	4	0
2	B	1915	0	1929	18	0
2	b	1915	0	1929	2	0
3	C	1904	0	1904	12	0
3	c	1904	0	1904	4	0
4	D	1881	0	1895	5	0
4	d	1881	0	1895	4	0
5	E	1861	0	1839	4	0
5	e	1861	0	1839	6	0
6	F	1795	0	1800	12	0
6	f	1773	0	1775	3	0
7	G	1892	0	1883	7	0
7	g	1892	0	1883	1	0
8	1	1512	0	1478	36	0
8	h	1512	0	1479	41	0
9	2	1719	0	1719	14	0
9	i	1719	0	1716	70	0

Continued on next page...

Continued from previous page...

Mol	Chain	Non-H	H(model)	H(added)	Clashes	Symm-Clashes
10	3	1581	0	1570	22	0
10	j	1581	0	1574	41	0
11	4	1561	0	1567	28	0
11	k	1561	0	1569	4	0
12	5	1644	0	1593	13	0
12	l	1644	0	1593	26	0
13	6	1757	0	1707	82	0
13	m	1757	0	1711	23	0
14	7	1790	0	1788	46	0
14	n	1815	0	1821	21	0
15	H	2967	0	3051	22	0
16	I	3022	0	3091	27	0
17	K	3078	0	3141	17	0
18	L	3082	0	3156	11	0
19	M	2986	0	3055	24	0
20	J	3033	0	3155	12	0
21	W	1534	0	1542	3	0
22	V	2274	0	2272	63	0
23	T	2192	0	2161	18	0
24	X	1032	0	1017	3	0
25	Y	435	0	394	2	0
26	Z	7005	0	6932	71	0
27	N	6882	0	6959	74	0
28	S	3894	0	3938	9	0
29	P	3608	0	3694	29	0
30	Q	3499	0	3524	23	0
31	R	3060	0	3083	37	0
32	U	2373	0	2403	7	0
33	O	3186	0	3213	11	0
34	H	31	0	13	3	0
34	I	31	0	13	4	0
34	J	31	0	13	8	0
34	K	31	0	13	2	0
34	L	31	0	13	0	0
35	H	1	0	0	0	0
35	I	1	0	0	0	0
35	J	1	0	0	0	0
35	K	1	0	0	0	0
35	L	1	0	0	0	0
35	M	1	0	0	0	0
36	M	27	0	12	12	0
All	All	108771	0	109020	761	0

The all-atom clashscore is defined as the number of clashes found per 1000 atoms (including hydrogen atoms). The all-atom clashscore for this structure is 3.

The worst 5 of 761 close contacts within the same asymmetric unit are listed below, sorted by their clash magnitude.

Atom-1	Atom-2	Interatomic distance (Å)	Clash overlap (Å)
22:V:117:TRP:CG	22:V:188:LEU:HD21	1.22	1.67
12:l:135:PHE:CD2	11:4:138:PHE:HE1	1.13	1.61
31:R:70:TYR:CB	31:R:70:TYR:CA	1.75	1.60
12:l:135:PHE:CG	11:4:138:PHE:CE1	1.96	1.54
12:l:135:PHE:CD2	11:4:138:PHE:CE1	1.96	1.54

There are no symmetry-related clashes.

5.3 Torsion angles [i](#)

5.3.1 Protein backbone [i](#)

In the following table, the Percentiles column shows the percent Ramachandran outliers of the chain as a percentile score with respect to all PDB entries followed by that with respect to all EM entries.

The Analysed column shows the number of residues for which the backbone conformation was analysed, and the total number of residues.

Mol	Chain	Analysed	Favoured	Allowed	Outliers	Percentiles	
1	A	239/252 (95%)	226 (95%)	10 (4%)	3 (1%)	9	42
1	a	239/252 (95%)	230 (96%)	8 (3%)	1 (0%)	30	67
2	B	248/250 (99%)	238 (96%)	7 (3%)	3 (1%)	10	44
2	b	248/250 (99%)	236 (95%)	8 (3%)	4 (2%)	7	38
3	C	242/258 (94%)	234 (97%)	7 (3%)	1 (0%)	30	67
3	c	242/258 (94%)	230 (95%)	11 (4%)	1 (0%)	30	67
4	D	238/254 (94%)	222 (93%)	12 (5%)	4 (2%)	7	36
4	d	238/254 (94%)	227 (95%)	10 (4%)	1 (0%)	30	67
5	E	240/260 (92%)	225 (94%)	11 (5%)	4 (2%)	7	36
5	e	240/260 (92%)	233 (97%)	4 (2%)	3 (1%)	9	42
6	F	231/234 (99%)	219 (95%)	9 (4%)	3 (1%)	9	42
6	f	229/234 (98%)	224 (98%)	5 (2%)	0	100	100

Continued on next page...

Continued from previous page...

Mol	Chain	Analysed	Favoured	Allowed	Outliers	Percentiles	
7	G	241/288 (84%)	230 (95%)	7 (3%)	4 (2%)	7	36
7	g	241/288 (84%)	231 (96%)	8 (3%)	2 (1%)	16	54
8	1	194/215 (90%)	185 (95%)	8 (4%)	1 (0%)	24	63
8	h	194/215 (90%)	185 (95%)	9 (5%)	0	100	100
9	2	224/261 (86%)	211 (94%)	11 (5%)	2 (1%)	14	51
9	i	224/261 (86%)	207 (92%)	14 (6%)	3 (1%)	9	42
10	3	202/205 (98%)	190 (94%)	10 (5%)	2 (1%)	12	49
10	j	202/205 (98%)	190 (94%)	12 (6%)	0	100	100
11	4	193/198 (98%)	187 (97%)	5 (3%)	1 (0%)	24	63
11	k	193/198 (98%)	181 (94%)	12 (6%)	0	100	100
12	5	210/287 (73%)	203 (97%)	7 (3%)	0	100	100
12	l	210/287 (73%)	204 (97%)	5 (2%)	1 (0%)	24	63
13	6	220/241 (91%)	209 (95%)	11 (5%)	0	100	100
13	m	220/241 (91%)	207 (94%)	12 (6%)	1 (0%)	24	63
14	7	227/266 (85%)	210 (92%)	12 (5%)	5 (2%)	5	29
14	n	230/266 (86%)	215 (94%)	15 (6%)	0	100	100
15	H	376/467 (80%)	340 (90%)	25 (7%)	11 (3%)	3	23
16	I	383/437 (88%)	349 (91%)	28 (7%)	6 (2%)	7	38
17	K	387/428 (90%)	354 (92%)	23 (6%)	10 (3%)	4	25
18	L	386/437 (88%)	362 (94%)	19 (5%)	5 (1%)	9	42
19	M	377/434 (87%)	342 (91%)	25 (7%)	10 (3%)	4	25
20	J	384/405 (95%)	354 (92%)	21 (6%)	9 (2%)	5	28
21	W	195/268 (73%)	184 (94%)	8 (4%)	3 (2%)	8	40
22	V	287/306 (94%)	263 (92%)	17 (6%)	7 (2%)	4	27
23	T	264/274 (96%)	241 (91%)	17 (6%)	6 (2%)	5	28
24	X	125/156 (80%)	99 (79%)	23 (18%)	3 (2%)	4	27
25	Y	47/89 (53%)	39 (83%)	7 (15%)	1 (2%)	5	30
26	Z	902/993 (91%)	835 (93%)	52 (6%)	15 (2%)	7	36
27	N	886/945 (94%)	837 (94%)	42 (5%)	7 (1%)	16	54
28	S	473/523 (90%)	441 (93%)	21 (4%)	11 (2%)	5	28
29	P	438/445 (98%)	410 (94%)	19 (4%)	9 (2%)	5	30

Continued on next page...

Continued from previous page...

Mol	Chain	Analysed	Favoured	Allowed	Outliers	Percentiles	
30	Q	432/434 (100%)	388 (90%)	28 (6%)	16 (4%)	2	20
31	R	377/429 (88%)	358 (95%)	16 (4%)	3 (1%)	16	54
32	U	296/338 (88%)	283 (96%)	8 (3%)	5 (2%)	7	36
33	O	386/393 (98%)	377 (98%)	6 (2%)	3 (1%)	16	54
All	All	13700/15139 (90%)	12845 (94%)	665 (5%)	190 (1%)	11	40

5 of 190 Ramachandran outliers are listed below:

Mol	Chain	Res	Type
1	A	215	GLU
2	B	93	ALA
5	E	114	ARG
11	4	25	ILE
15	H	77	ALA

5.3.2 Protein sidechains [i](#)

There are no protein residues with a non-rotameric sidechain to report in this entry.

5.3.3 RNA [i](#)

There are no RNA molecules in this entry.

5.4 Non-standard residues in protein, DNA, RNA chains [i](#)

There are no non-standard protein/DNA/RNA residues in this entry.

5.5 Carbohydrates [i](#)

There are no oligosaccharides in this entry.

5.6 Ligand geometry [i](#)

Of 12 ligands modelled in this entry, 6 are monoatomic - leaving 6 for Mogul analysis.

In the following table, the Counts columns list the number of bonds (or angles) for which Mogul statistics could be retrieved, the number of bonds (or angles) that are observed in the model and the number of bonds (or angles) that are defined in the Chemical Component Dictionary. The

Link column lists molecule types, if any, to which the group is linked. The Z score for a bond length (or angle) is the number of standard deviations the observed value is removed from the expected value. A bond length (or angle) with $|Z| > 2$ is considered an outlier worth inspection. RMSZ is the root-mean-square of all Z scores of the bond lengths (or angles).

Mol	Type	Chain	Res	Link	Bond lengths			Bond angles		
					Counts	RMSZ	# Z > 2	Counts	RMSZ	# Z > 2
34	ANP	L	501	35	33,33,33	3.41	10 (30%)	45,52,52	2.28	12 (26%)
36	ADP	M	501	35	28,29,29	1.31	4 (14%)	43,45,45	1.81	13 (30%)
34	ANP	H	501	35	33,33,33	3.89	11 (33%)	45,52,52	2.22	11 (24%)
34	ANP	K	501	35	33,33,33	2.66	11 (33%)	45,52,52	2.19	12 (26%)
34	ANP	J	501	35	33,33,33	2.94	10 (30%)	45,52,52	2.20	10 (22%)
34	ANP	I	501	35	33,33,33	3.76	11 (33%)	45,52,52	2.21	12 (26%)

In the following table, the Chirals column lists the number of chiral outliers, the number of chiral centers analysed, the number of these observed in the model and the number defined in the Chemical Component Dictionary. Similar counts are reported in the Torsion and Rings columns. '-' means no outliers of that kind were identified.

Mol	Type	Chain	Res	Link	Chirals	Torsions	Rings
34	ANP	L	501	35	-	4/18/38/38	0/3/3/3
36	ADP	M	501	35	-	8/16/32/32	0/3/3/3
34	ANP	H	501	35	-	8/18/38/38	0/3/3/3
34	ANP	K	501	35	-	3/18/38/38	0/3/3/3
34	ANP	J	501	35	-	5/18/38/38	0/3/3/3
34	ANP	I	501	35	-	8/18/38/38	0/3/3/3

The worst 5 of 57 bond length outliers are listed below:

Mol	Chain	Res	Type	Atoms	Z	Observed(Å)	Ideal(Å)
34	H	501	ANP	PB-O3A	16.05	1.79	1.59
34	I	501	ANP	PB-O3A	14.85	1.77	1.59
34	L	501	ANP	PB-O3A	14.31	1.76	1.59
34	H	501	ANP	PA-O3A	10.91	1.71	1.59
34	J	501	ANP	PB-O3A	10.44	1.72	1.59

The worst 5 of 70 bond angle outliers are listed below:

Mol	Chain	Res	Type	Atoms	Z	Observed(°)	Ideal(°)
34	J	501	ANP	O1G-PG-N3B	-9.11	98.36	111.77
34	I	501	ANP	O1G-PG-N3B	-9.03	98.48	111.77
34	L	501	ANP	O1G-PG-N3B	-7.51	100.72	111.77

Continued on next page...

Continued from previous page...

Mol	Chain	Res	Type	Atoms	Z	Observed(°)	Ideal(°)
34	K	501	ANP	O1G-PG-N3B	-7.26	101.07	111.77
34	H	501	ANP	O1G-PG-N3B	-6.99	101.48	111.77

There are no chirality outliers.

5 of 36 torsion outliers are listed below:

Mol	Chain	Res	Type	Atoms
34	H	501	ANP	PB-N3B-PG-O1G
34	H	501	ANP	PG-N3B-PB-O1B
34	H	501	ANP	C5'-O5'-PA-O1A
34	H	501	ANP	C5'-O5'-PA-O3A
34	I	501	ANP	PG-N3B-PB-O3A

There are no ring outliers.

5 monomers are involved in 29 short contacts:

Mol	Chain	Res	Type	Clashes	Symm-Clashes
36	M	501	ADP	12	0
34	H	501	ANP	3	0
34	K	501	ANP	2	0
34	J	501	ANP	8	0
34	I	501	ANP	4	0

The following is a two-dimensional graphical depiction of Mogul quality analysis of bond lengths, bond angles, torsion angles, and ring geometry for all instances of the Ligand of Interest. In addition, ligands with molecular weight > 250 and outliers as shown on the validation Tables will also be included. For torsion angles, if less than 5% of the Mogul distribution of torsion angles is within 10 degrees of the torsion angle in question, then that torsion angle is considered an outlier. Any bond that is central to one or more torsion angles identified as an outlier by Mogul will be highlighted in the graph. For rings, the root-mean-square deviation (RMSD) between the ring in question and similar rings identified by Mogul is calculated over all ring torsion angles. If the average RMSD is greater than 60 degrees and the minimal RMSD between the ring in question and any Mogul-identified rings is also greater than 60 degrees, then that ring is considered an outlier. The outliers are highlighted in purple. The color gray indicates Mogul did not find sufficient equivalents in the CSD to analyse the geometry.

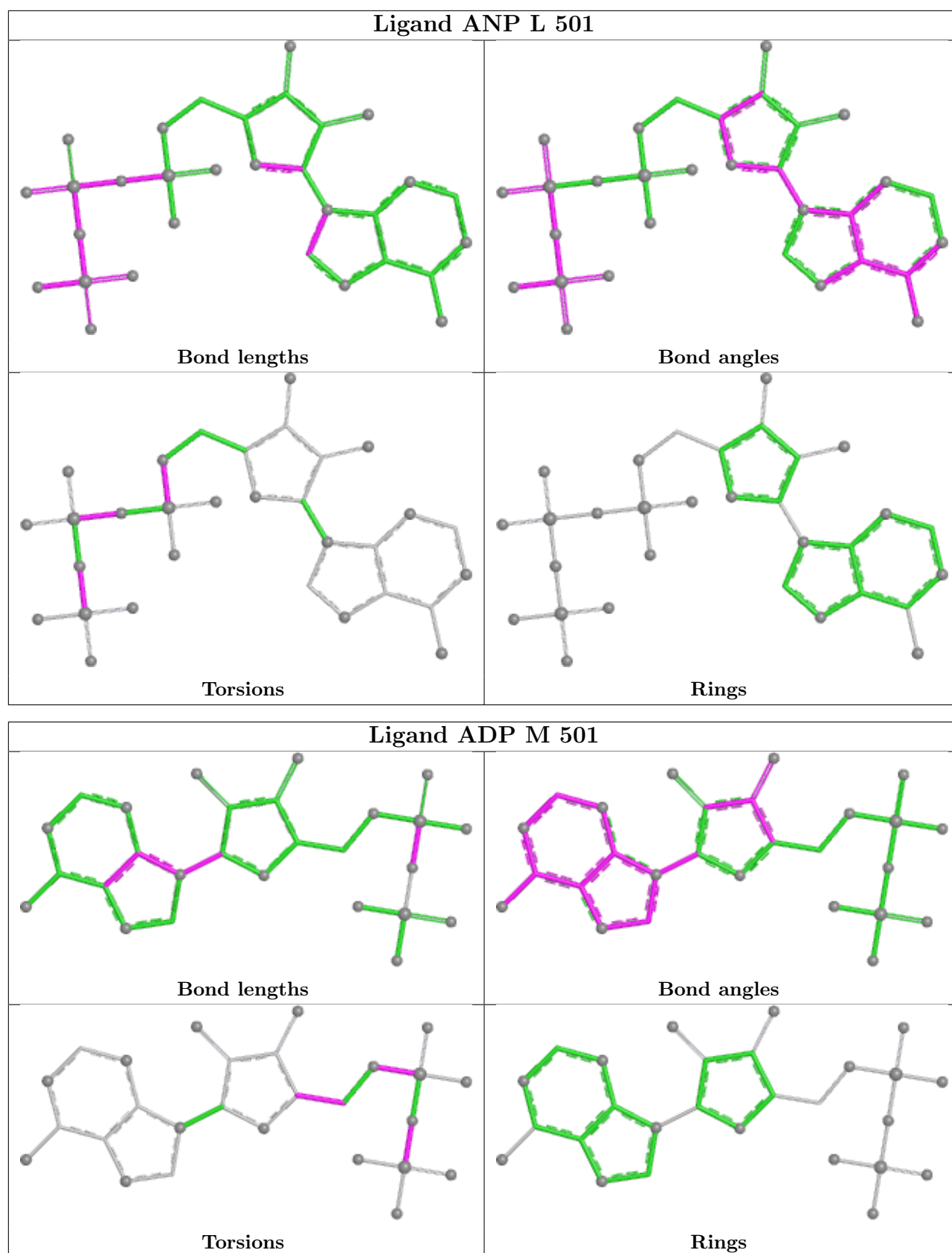

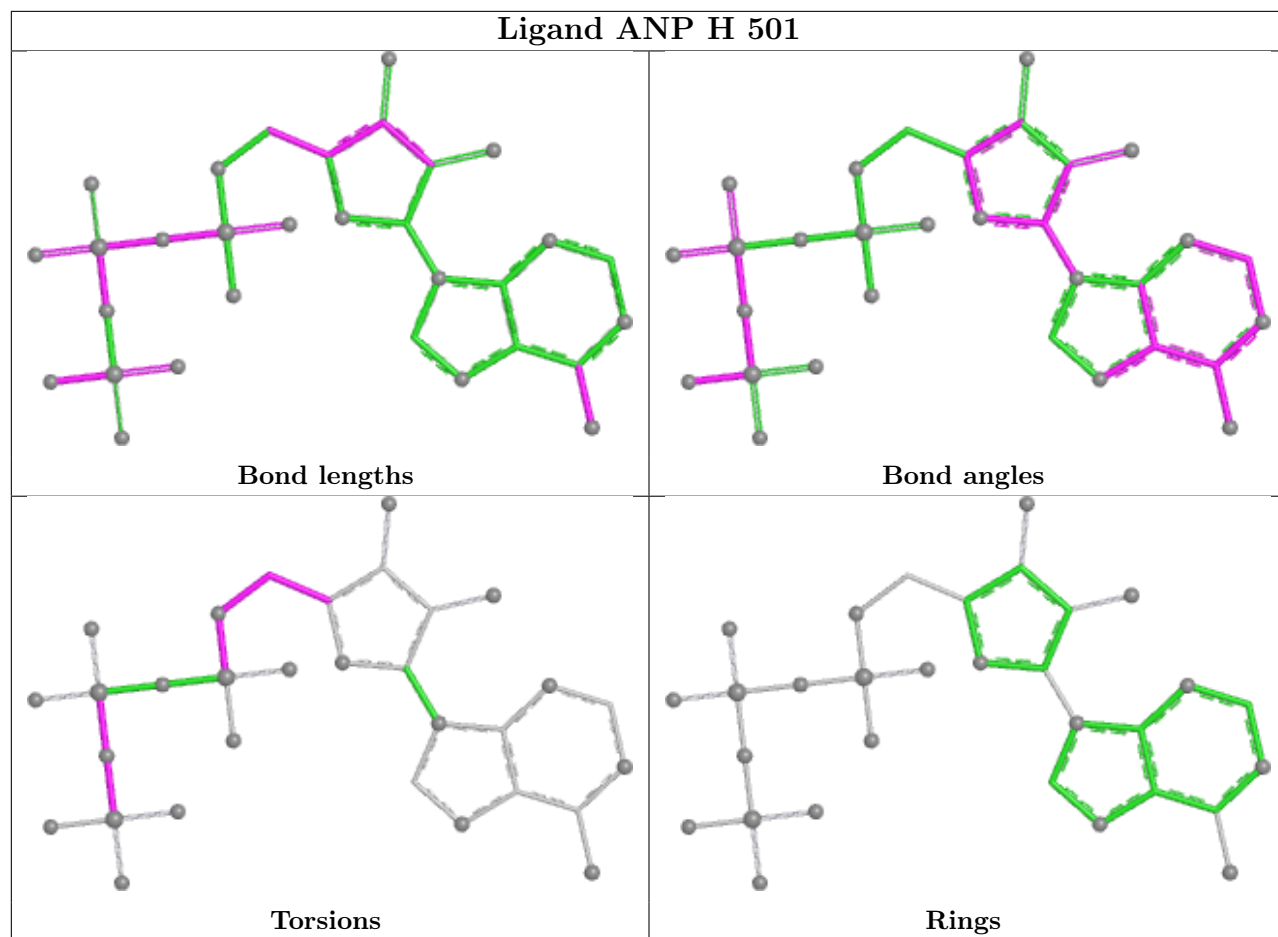

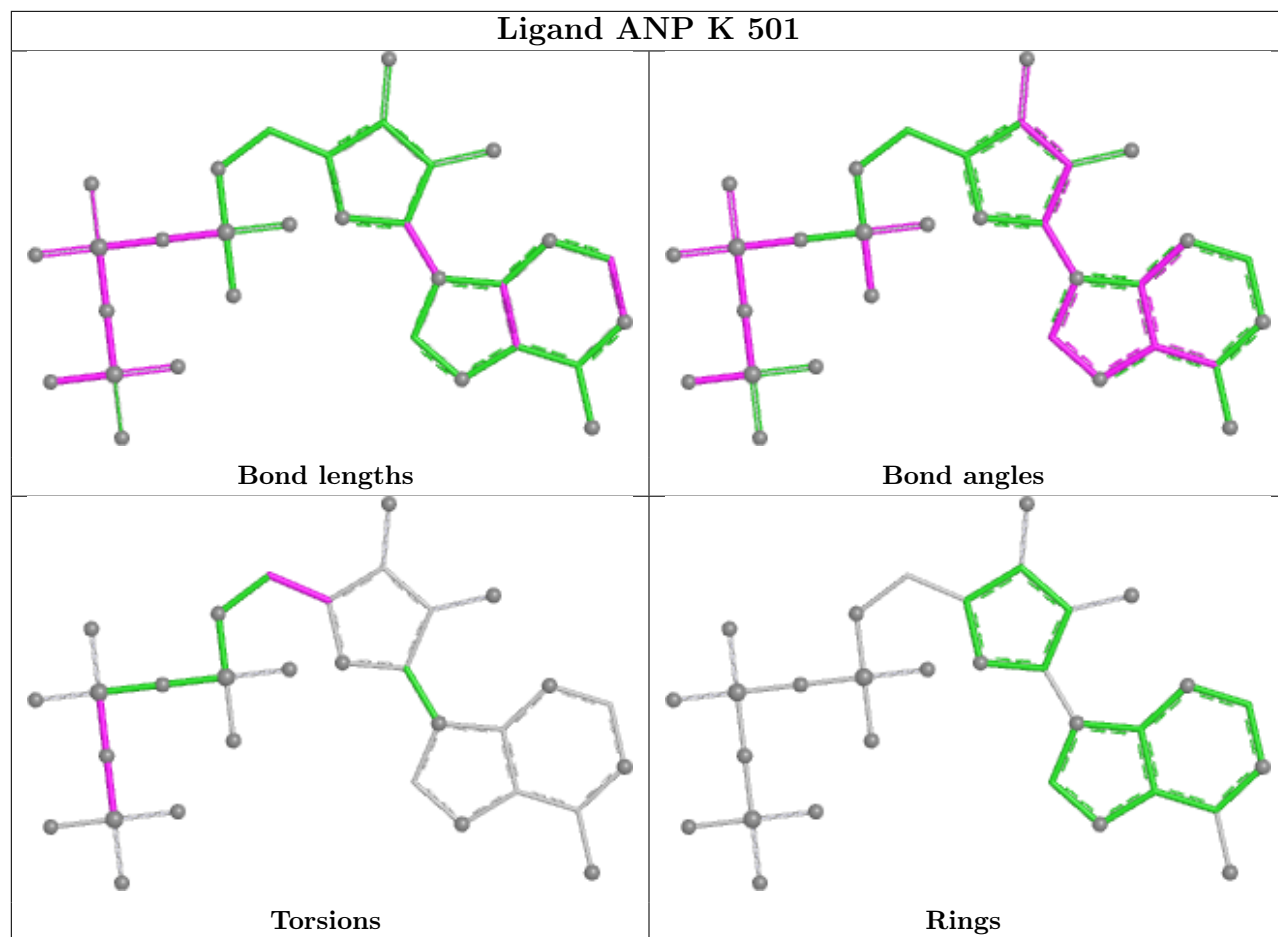

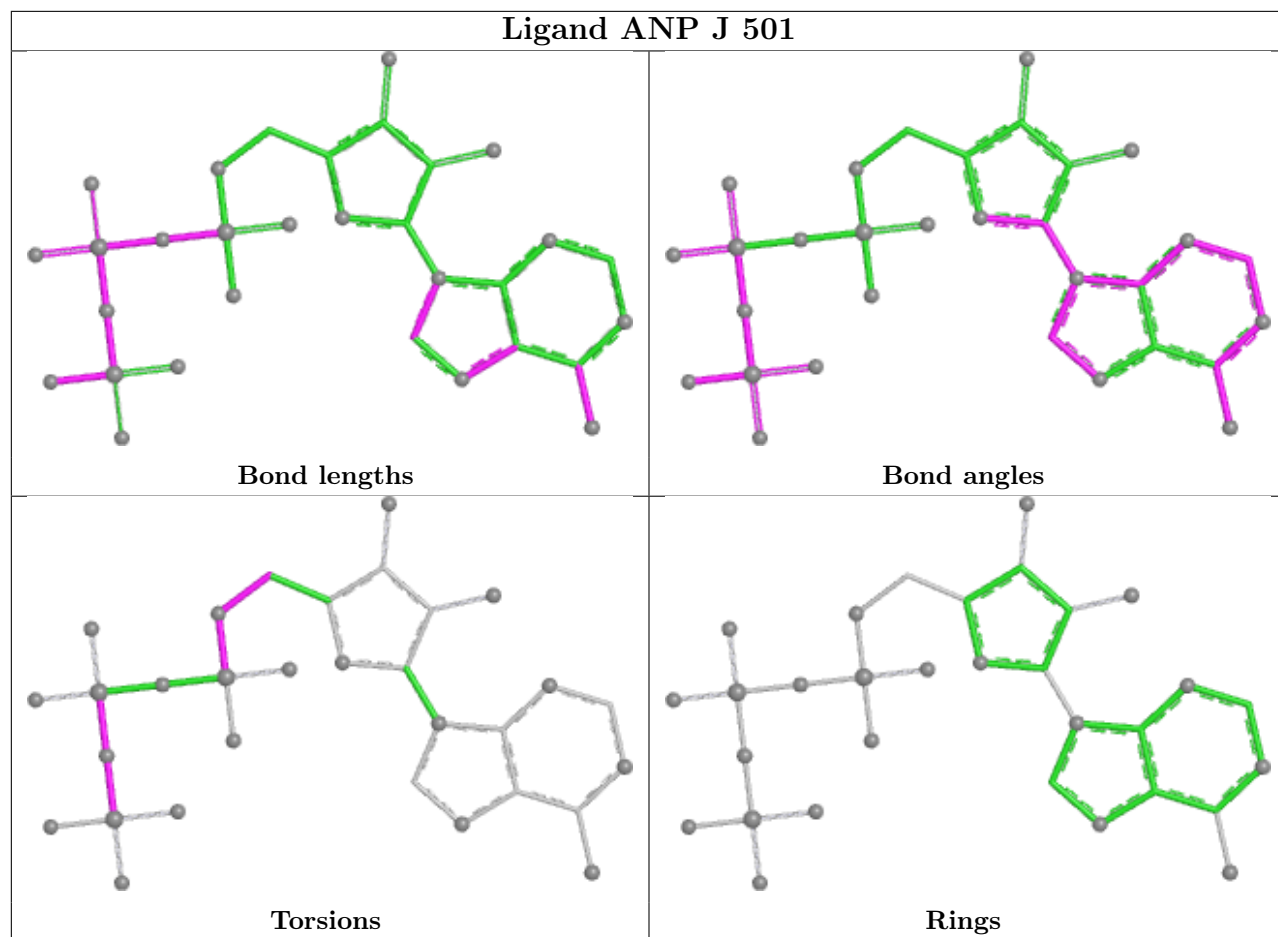

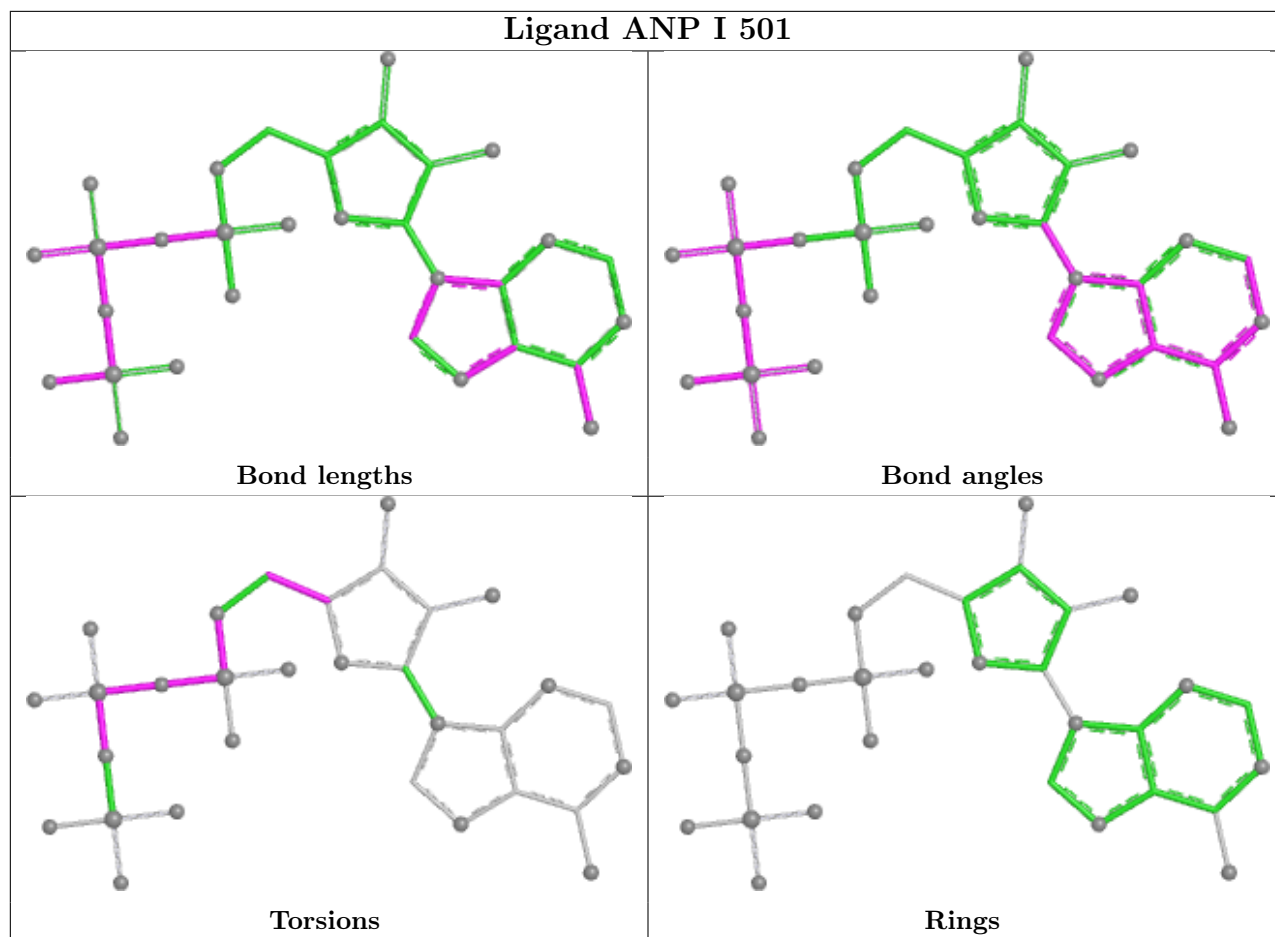

5.7 Other polymers [i](#)

There are no such residues in this entry.

5.8 Polymer linkage issues [i](#)

The following chains have linkage breaks:

Mol	Chain	Number of breaks
22	V	1

All chain breaks are listed below:

Model	Chain	Residue-1	Atom-1	Residue-2	Atom-2	Distance (Å)
1	V	186:GLN	C	187:ALA	N	1.19

6 Map visualisation [i](#)

This section contains visualisations of the EMDB entry EMD-3536. These allow visual inspection of the internal detail of the map and identification of artifacts.

No raw map or half-maps were deposited for this entry and therefore no images, graphs, etc. pertaining to the raw map can be shown.

6.1 Orthogonal projections [i](#)

6.1.1 Primary map

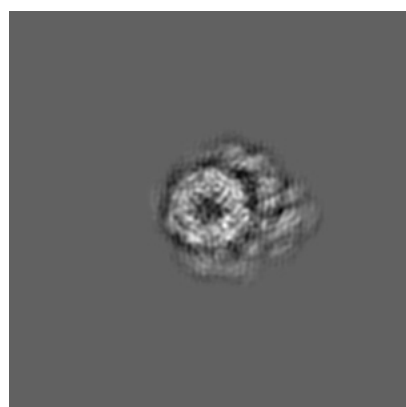

X

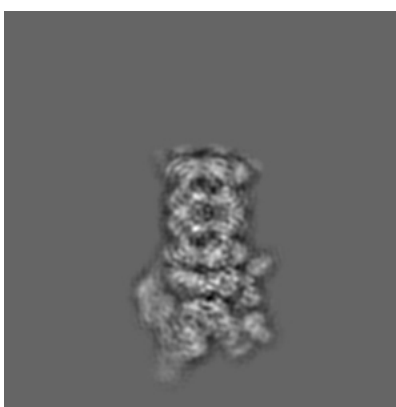

Y

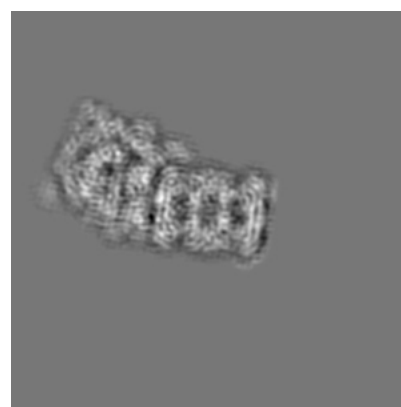

Z

The images above show the map projected in three orthogonal directions.

6.2 Central slices [i](#)

6.2.1 Primary map

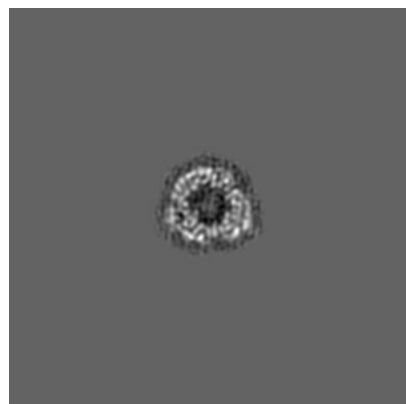

X Index: 208

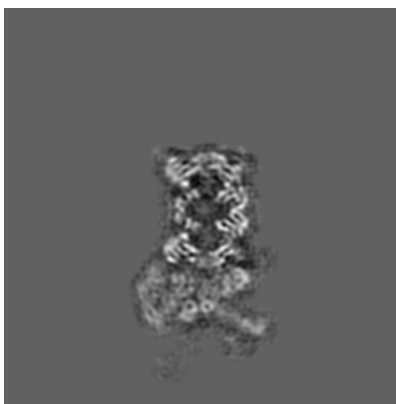

Y Index: 208

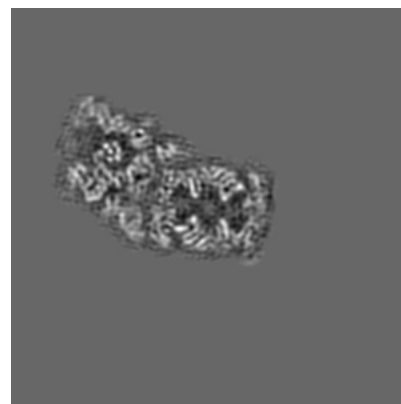

Z Index: 208

The images above show central slices of the map in three orthogonal directions.

6.3 Largest variance slices [i](#)

6.3.1 Primary map

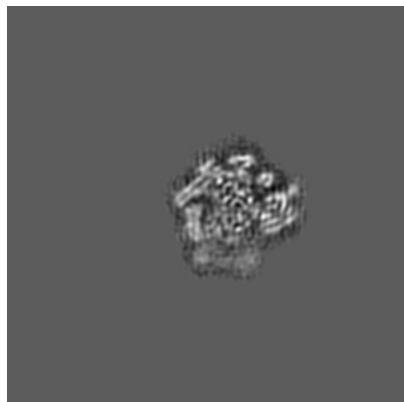

X Index: 135

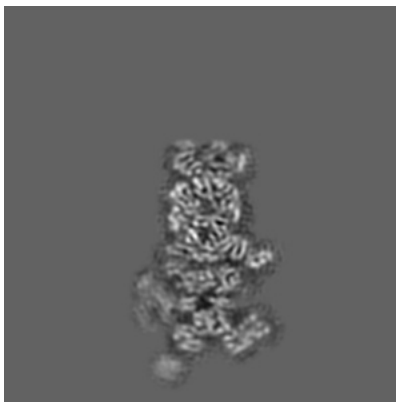

Y Index: 226

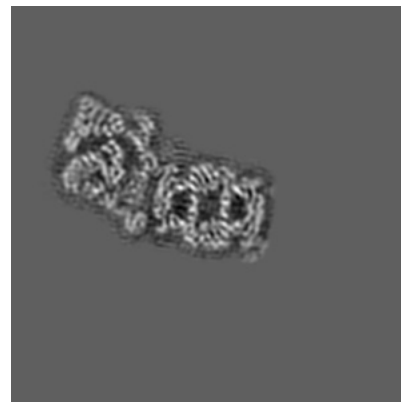

Z Index: 199

The images above show the largest variance slices of the map in three orthogonal directions.

6.4 Orthogonal standard-deviation projections (False-color) [i](#)

6.4.1 Primary map

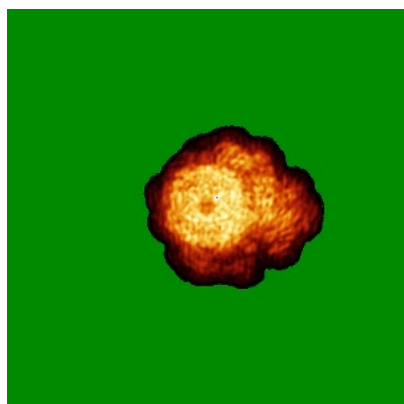

X

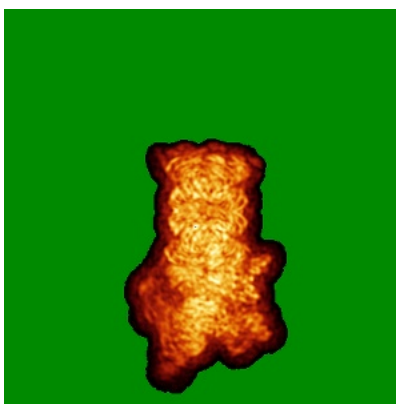

Y

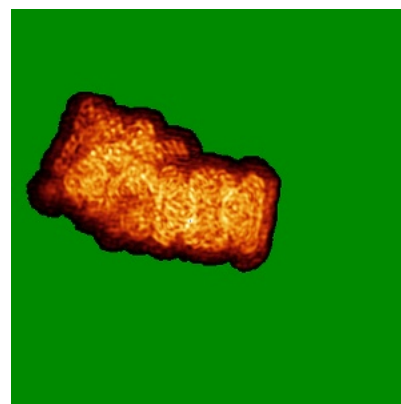

Z

The images above show the map standard deviation projections with false color in three orthogonal directions. Minimum values are shown in green, max in blue, and dark to light orange shades represent small to large values respectively.

6.5 Orthogonal surface views [i](#)

6.5.1 Primary map

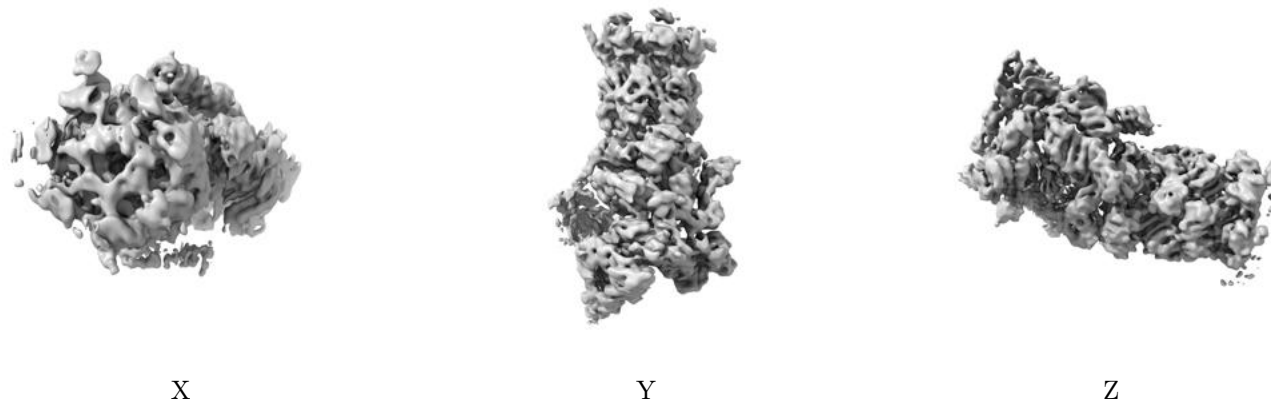

The images above show the 3D surface view of the map at the recommended contour level 0.019. These images, in conjunction with the slice images, may facilitate assessment of whether an appropriate contour level has been provided.

6.6 Mask visualisation [i](#)

This section was not generated. No masks/segmentation were deposited.

7 Map analysis [i](#)

This section contains the results of statistical analysis of the map.

7.1 Map-value distribution [i](#)

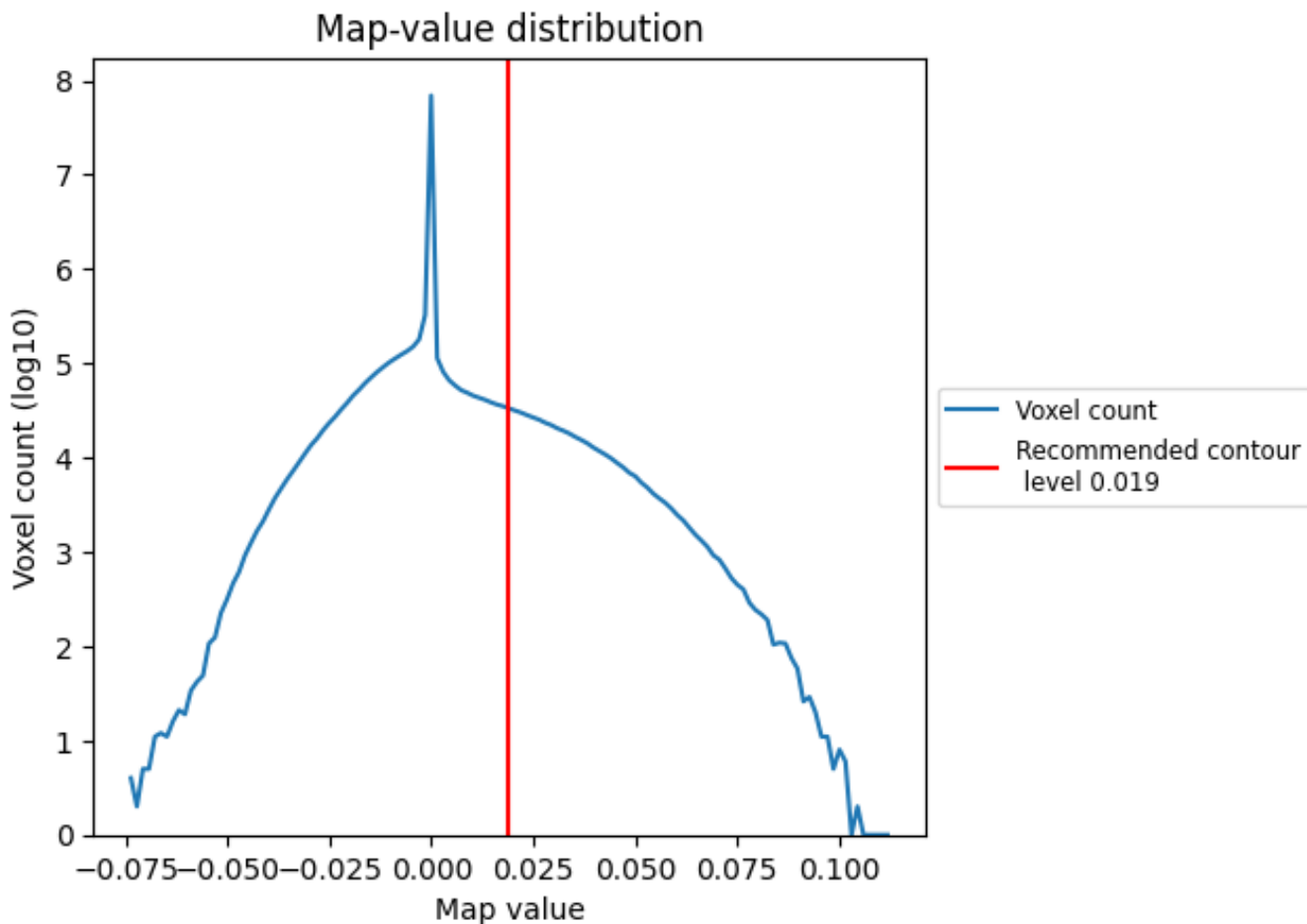

The map-value distribution is plotted in 128 intervals along the x-axis. The y-axis is logarithmic. A spike in this graph at zero usually indicates that the volume has been masked.

7.2 Volume estimate [i](#)

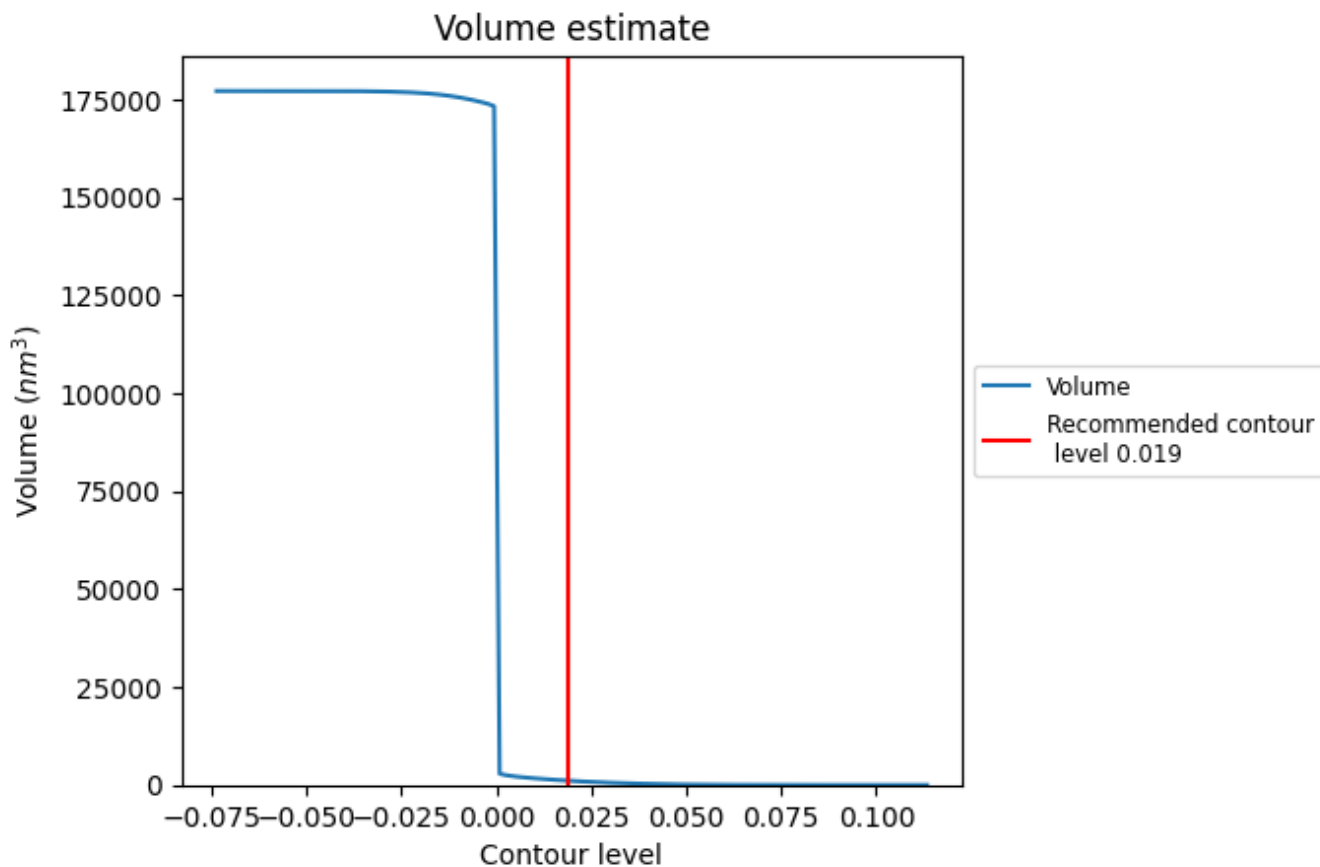

The volume at the recommended contour level is 1087 nm³; this corresponds to an approximate mass of 982 kDa.

The volume estimate graph shows how the enclosed volume varies with the contour level. The recommended contour level is shown as a vertical line and the intersection between the line and the curve gives the volume of the enclosed surface at the given level.

7.3 Rotationally averaged power spectrum [i](#)

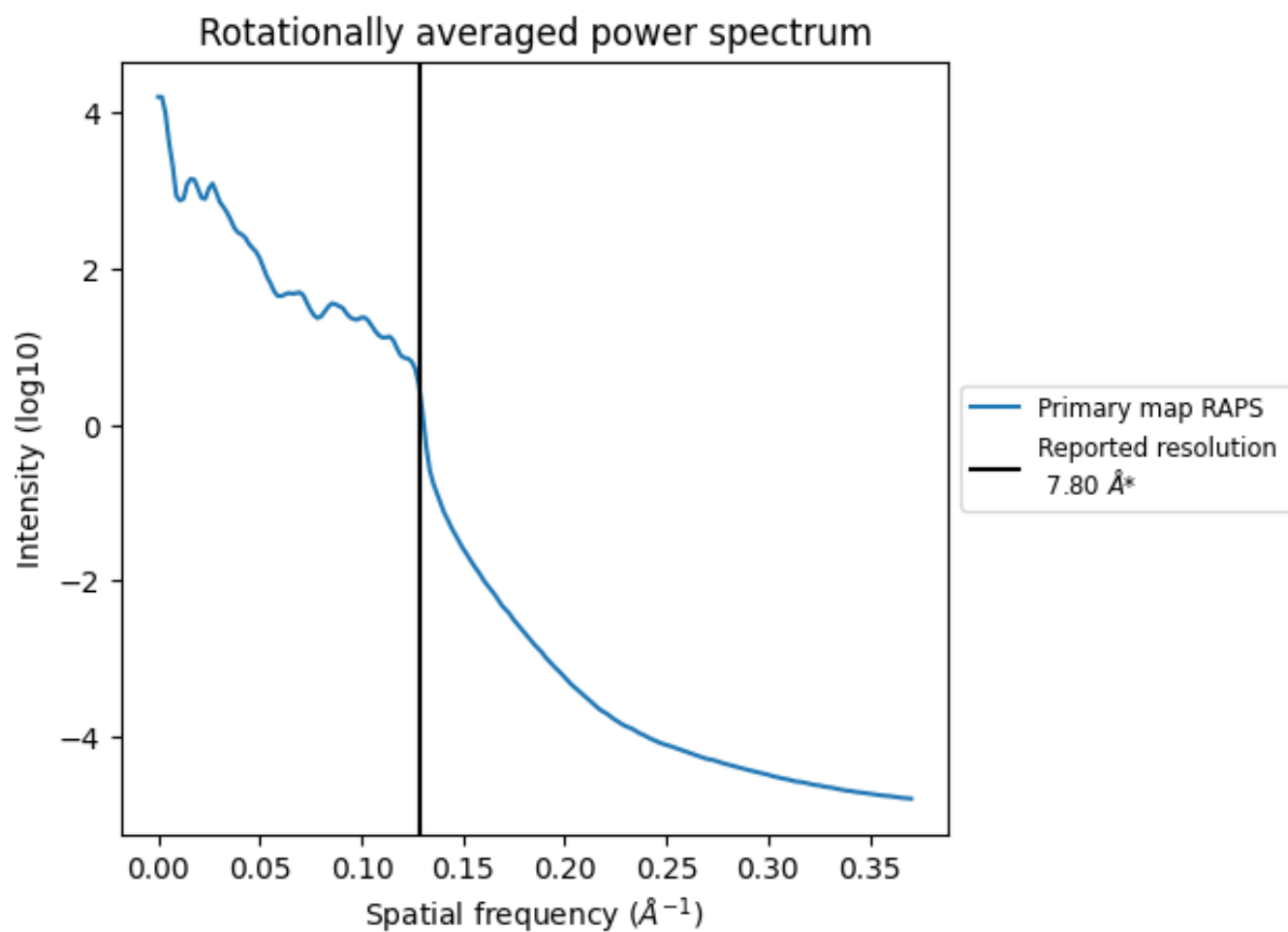

*Reported resolution corresponds to spatial frequency of 0.128\AA^{-1}

8 Fourier-Shell correlation

This section was not generated. No FSC curve or half-maps provided.

9 Map-model fit [i](#)

This section contains information regarding the fit between EMDB map EMD-3536 and PDB model 5MPB. Per-residue inclusion information can be found in section [3](#) on page [13](#).

9.1 Map-model overlay [i](#)

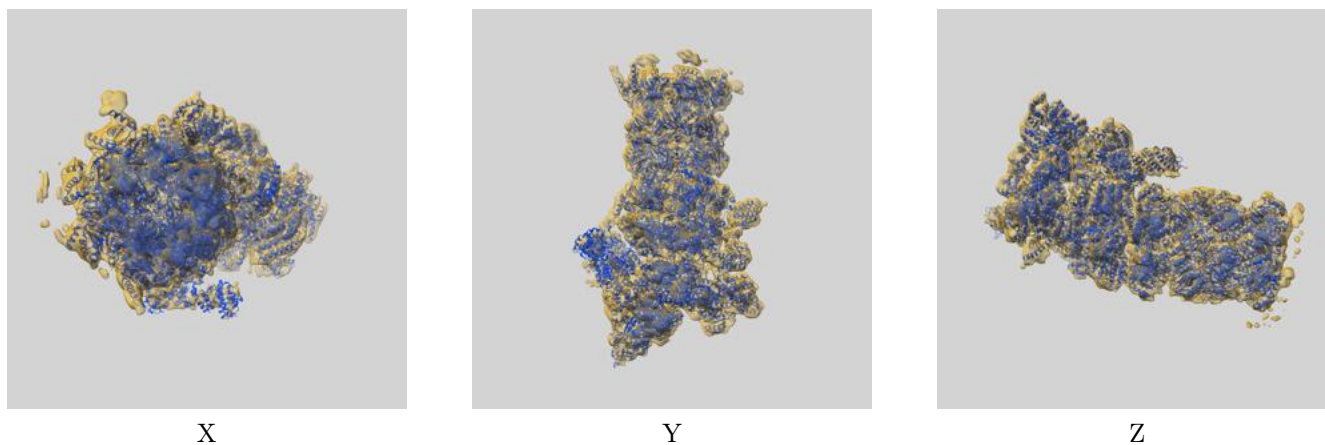

The images above show the 3D surface view of the map at the recommended contour level 0.019 at 50% transparency in yellow overlaid with a ribbon representation of the model coloured in blue. These images allow for the visual assessment of the quality of fit between the atomic model and the map.

9.2 Q-score mapped to coordinate model [i](#)

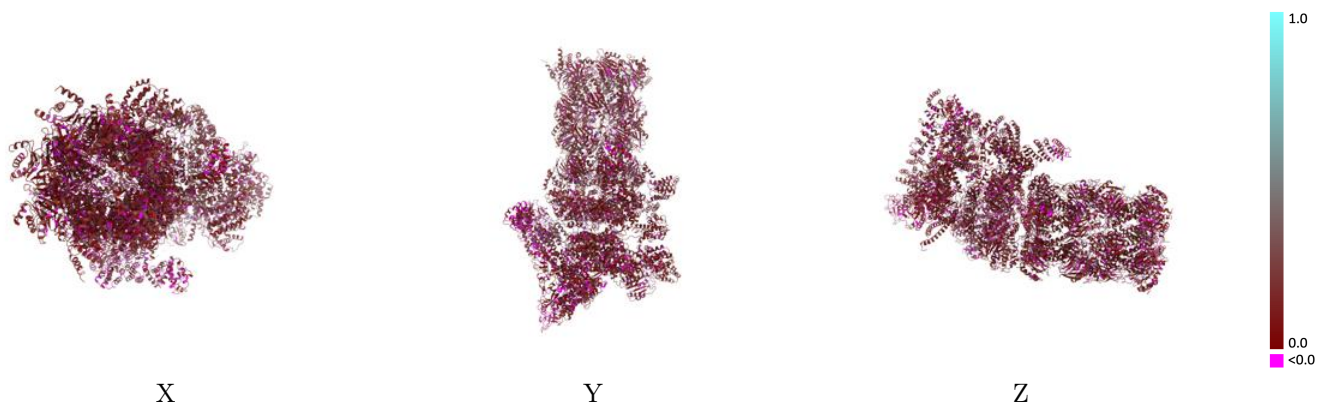

The images above show the model with each residue coloured according to its Q-score. This shows their resolvability in the map with higher Q-score values reflecting better resolvability. Please note: Q-score is calculating the resolvability of atoms, and thus high values are only expected at resolutions at which atoms can be resolved. Low Q-score values may therefore be expected for many entries.

9.3 Atom inclusion mapped to coordinate model [i](#)

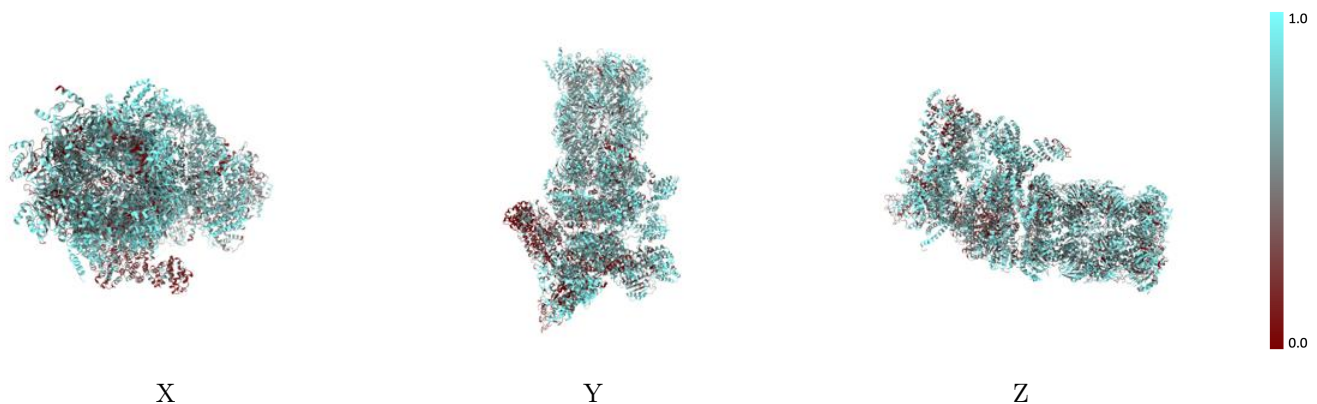

The images above show the model with each residue coloured according to its atom inclusion. This shows to what extent they are inside the map at the recommended contour level (0.019).



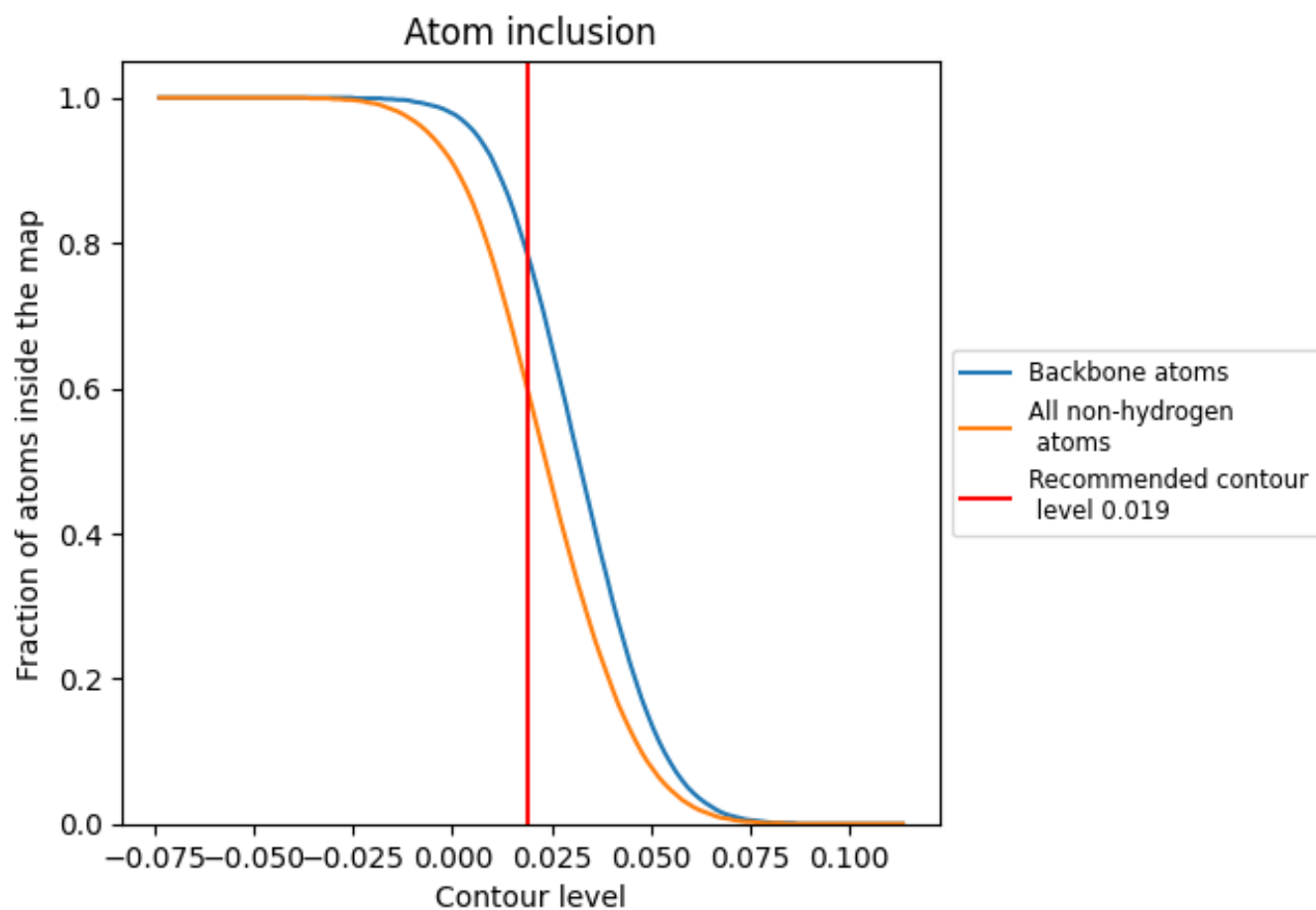



































































9.4 Atom inclusion [i](#)



At the recommended contour level, 78% of all backbone atoms, 60% of all non-hydrogen atoms, are inside the map.

9.5 Map-model fit summary



























The table lists the average atom inclusion at the recommended contour level (0.019) and Q-score for the entire model and for each chain.

Chain	Atom inclusion	Q-score
All	 0.5970	 0.1320
1	 0.6860	 0.1420
2	 0.6740	 0.1490
3	 0.6090	 0.1400
4	 0.6800	 0.1450
5	 0.7210	 0.1460
6	 0.6950	 0.1410
7	 0.6750	 0.1420
A	 0.6110	 0.1320
B	 0.5870	 0.1420
C	 0.6230	 0.1430
D	 0.6510	 0.1410
E	 0.6370	 0.1460
F	 0.6660	 0.1450
G	 0.6730	 0.1440
H	 0.5790	 0.1290
I	 0.4350	 0.1190
J	 0.5370	 0.1260
K	 0.5520	 0.1250
L	 0.5880	 0.1350
M	 0.5350	 0.1290
N	 0.5910	 0.1320
O	 0.6850	 0.1470
P	 0.7720	 0.1510
Q	 0.6960	 0.1370
R	 0.7160	 0.1460
S	 0.5750	 0.1300
T	 0.5040	 0.1260
U	 0.5900	 0.1380
V	 0.6060	 0.1380
W	 0.5940	 0.1200
X	 0.2580	 0.0610
Y	 0.4650	 0.1010
Z	 0.2840	 0.0710
a	 0.6220	 0.1400



Continued on next page...

Continued from previous page...

Chain	Atom inclusion	Q-score
b	 0.5670	 0.1360
c	 0.5880	 0.1410
d	 0.6470	 0.1360
e	 0.6200	 0.1450
f	 0.6480	 0.1460
g	 0.6540	 0.1440
h	 0.6740	 0.1410
i	 0.6270	 0.1350
j	 0.5930	 0.1320
k	 0.6850	 0.1430
l	 0.6910	 0.1370
m	 0.6700	 0.1330
n	 0.6420	 0.1350