



wwPDB EM Validation Summary Report ⓘ

Mar 15, 2026 – 10:19 AM UTC

PDB ID : 7PMV / pdb_00007pmv
EMDB ID : EMD-13541
Title : VWF Tubules of D1D2D'D3 domains
Authors : Javitt, G.; Fass, D.
Deposited on : 2021-09-02
Resolution : 3.70 Å(reported)

This is a wwPDB EM Validation Summary Report for a publicly released PDB entry.

We welcome your comments at validation@mail.wwpdb.org

A user guide is available at

<https://www.wwpdb.org/validation/2017/EMValidationReportHelp>

with specific help available everywhere you see the ⓘ symbol.

The types of validation reports are described at

<http://www.wwpdb.org/validation/2017/FAQs#types>.

The following versions of software and data (see [references ⓘ](#)) were used in the production of this report:

EMDB validation analysis : 0.0.1.dev132
Mogul : 2022.3.0, CSD as543be (2022)
MolProbity : 4-5-2 with Phenix2.0
Percentile statistics : 20250101.v01 (using entries in the PDB archive January 1st 2025)
EM percentile statistics : 202505.v01 (Using data in the EMDB archive up until May 2025)
MapQ : 1.9.13
Ideal geometry (proteins) : Engh & Huber (2001)
Ideal geometry (DNA, RNA) : Parkinson et al. (1996)
Validation Pipeline (wwPDB-VP) : 2.49

1 Overall quality at a glance i

The following experimental techniques were used to determine the structure:
ELECTRON MICROSCOPY

The reported resolution of this entry is 3.70 Å.

Percentile scores (ranging between 0-100) for global validation metrics of the entry are shown in the following graphic. The table shows the number of entries on which the scores are based.

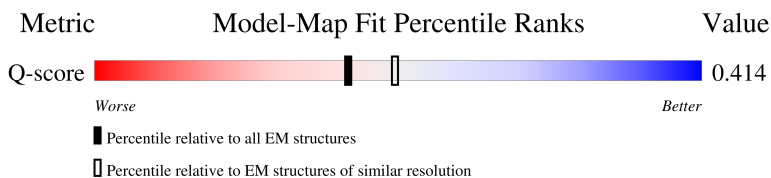
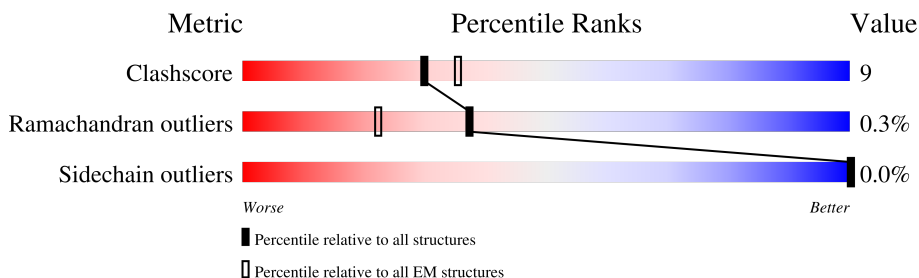



Metric	Whole archive (#Entries)	EM structures (#Entries)	Similar EM resolution (#Entries, resolution range(Å))
Clashscore	229148	23984	-
Ramachandran outliers	224038	23583	-
Sidechain outliers	223484	23102	-
Q-score	-	25397	11569 (3.20 - 4.20)

The table below summarises the geometric issues observed across the polymeric chains and their fit to the map. The red, orange, yellow and green segments of the bar indicate the fraction of residues that contain outliers for ≥ 3 , 2, 1 and 0 types of geometric quality criteria respectively. A grey segment represents the fraction of residues that are not modelled. The numeric value for each fraction is indicated below the corresponding segment, with a dot representing fractions $\leq 5\%$. The upper red bar (where present) indicates the fraction of residues that have poor fit to the EM map (all-atom inclusion $< 40\%$). The numeric value is given above the bar.

Mol	Chain	Length	Quality of chain
1	A	1241	
1	B	1241	
1	D	1241	
1	E	1241	

Continued on next page...

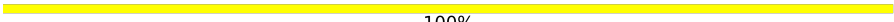
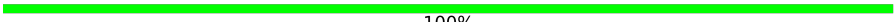
Continued from previous page...

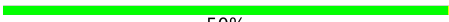
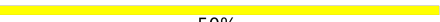
Mol	Chain	Length	Quality of chain
2	C	3	 100%
2	F	3	 100%
2	G	3	 100%
3	H	2	 50%  50%

2 Entry composition [i](#)

There are 6 unique types of molecules in this entry. The entry contains 68226 atoms, of which 32883 are hydrogens and 0 are deuteriums.

In the tables below, the AltConf column contains the number of residues with at least one atom in alternate conformation and the Trace column contains the number of residues modelled with at most 2 atoms.

- Molecule 1 is a protein called von Willebrand factor.

Mol	Chain	Residues	Atoms						AltConf	Trace
			Total	C	H	N	O	S		
1	A	1139	16899	5398	8165	1510	1696	130	2	0
1	B	1141	16916	5404	8171	1512	1698	131	2	0
1	D	1141	16917	5404	8172	1512	1698	131	2	0
1	E	1139	16899	5398	8165	1510	1696	130	2	0

There are 4 discrepancies between the modelled and reference sequences:

Chain	Residue	Modelled	Actual	Comment	Reference
A	852	ARG	GLN	variant	UNP P04275
B	852	ARG	GLN	variant	UNP P04275
D	852	ARG	GLN	variant	UNP P04275
E	852	ARG	GLN	variant	UNP P04275

- Molecule 2 is an oligosaccharide called beta-D-mannopyranose-(1-4)-2-acetamido-2-deoxy-beta-D-glucopyranose-(1-4)-2-acetamido-2-deoxy-beta-D-glucopyranose.

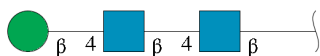

Mol	Chain	Residues	Atoms					AltConf	Trace
			Total	C	H	N	O		
2	C	3	61	22	22	2	15	0	0
2	F	3	61	22	22	2	15	0	0
2	G	3	61	22	22	2	15	0	0

- Molecule 3 is an oligosaccharide called 2-acetamido-2-deoxy-beta-D-glucopyranose-(1-4)-2-a

cetamido-2-deoxy-beta-D-glucopyranose.



Mol	Chain	Residues	Atoms					AltConf	Trace
			Total	C	H	N	O		
3	H	2	44	16	16	2	10	0	0

- Molecule 4 is 2-acetamido-2-deoxy-beta-D-glucopyranose (CCD ID: NAG) (formula: C₈H₁₅NO₆).

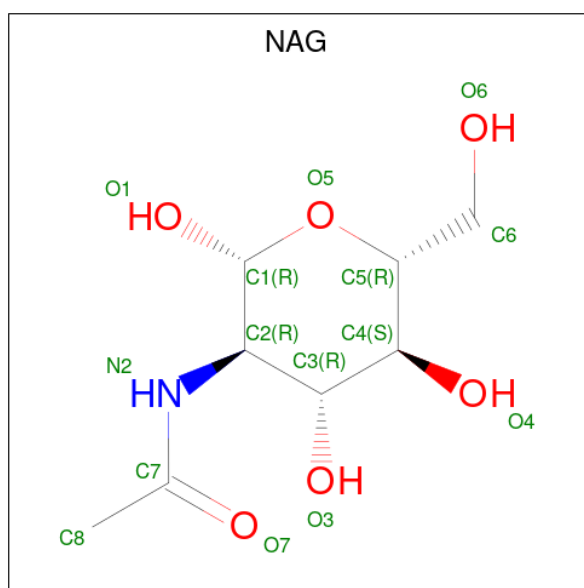

Mol	Chain	Residues	Atoms					AltConf
			Total	C	H	N	O	
4	A	1	22	8	8	1	5	0
4	A	1	22	8	8	1	5	0
4	A	1	22	8	8	1	5	0
4	A	1	22	8	8	1	5	0
4	B	1	22	8	8	1	5	0
4	B	1	22	8	8	1	5	0
4	B	1	22	8	8	1	5	0

Continued on next page...

Continued from previous page...

Mol	Chain	Residues	Atoms					AltConf
4	B	1	Total	C	H	N	O	0
			22	8	8	1	5	
4	D	1	Total	C	H	N	O	0
			22	8	8	1	5	
4	D	1	Total	C	H	N	O	0
			22	8	8	1	5	
4	D	1	Total	C	H	N	O	0
			22	8	8	1	5	
4	D	1	Total	C	H	N	O	0
			22	8	8	1	5	
4	E	1	Total	C	H	N	O	0
			22	8	8	1	5	
4	E	1	Total	C	H	N	O	0
			22	8	8	1	5	
4	E	1	Total	C	H	N	O	0
			22	8	8	1	5	
4	E	1	Total	C	H	N	O	0
			22	8	8	1	5	

- Molecule 5 is CALCIUM ION (CCD ID: CA) (formula: Ca).

Mol	Chain	Residues	Atoms		AltConf
5	A	3	Total	Ca	0
			3	3	
5	B	3	Total	Ca	0
			3	3	
5	D	3	Total	Ca	0
			3	3	
5	E	3	Total	Ca	0
			3	3	

- Molecule 6 is water.

Mol	Chain	Residues	Atoms		AltConf
6	B	4	Total	O	0
			4	4	

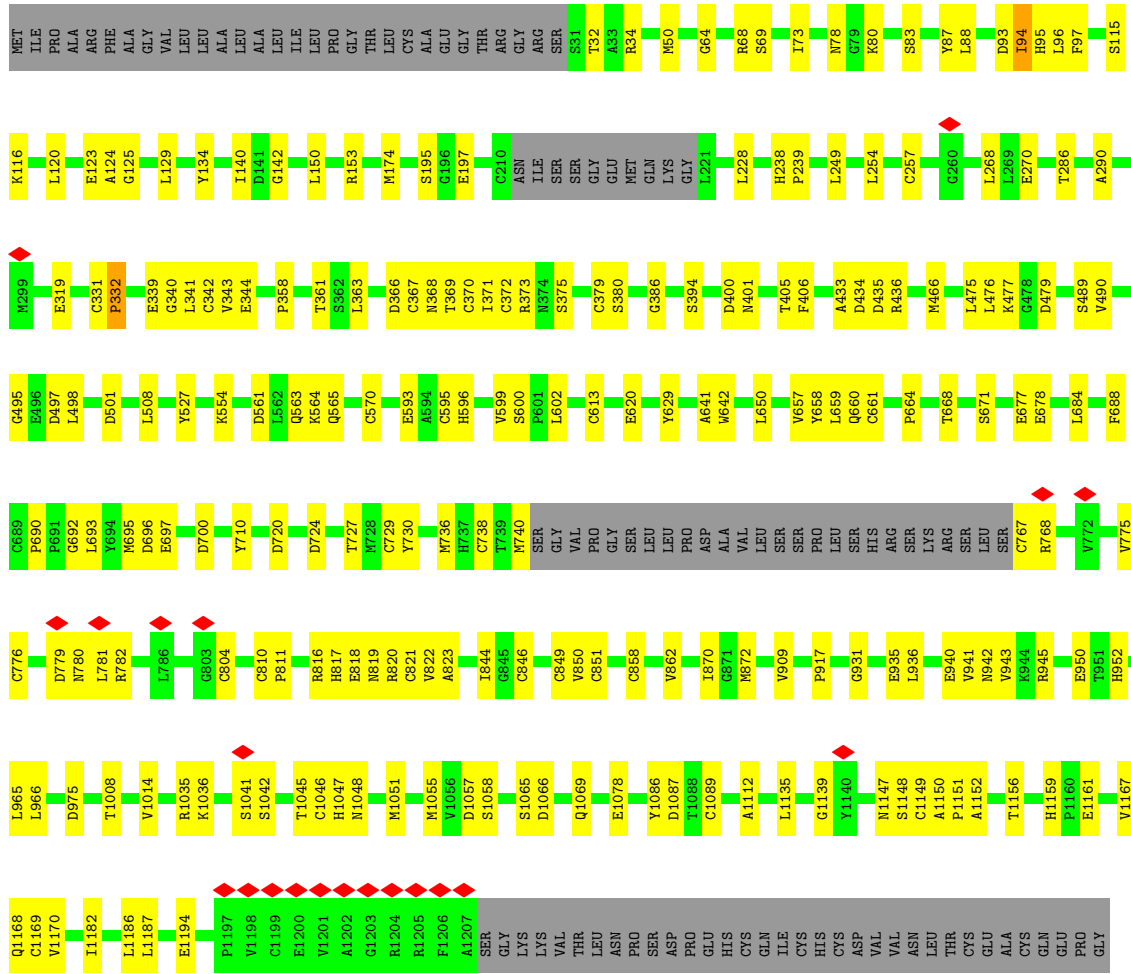

• Molecule 1: von Willebrand factor

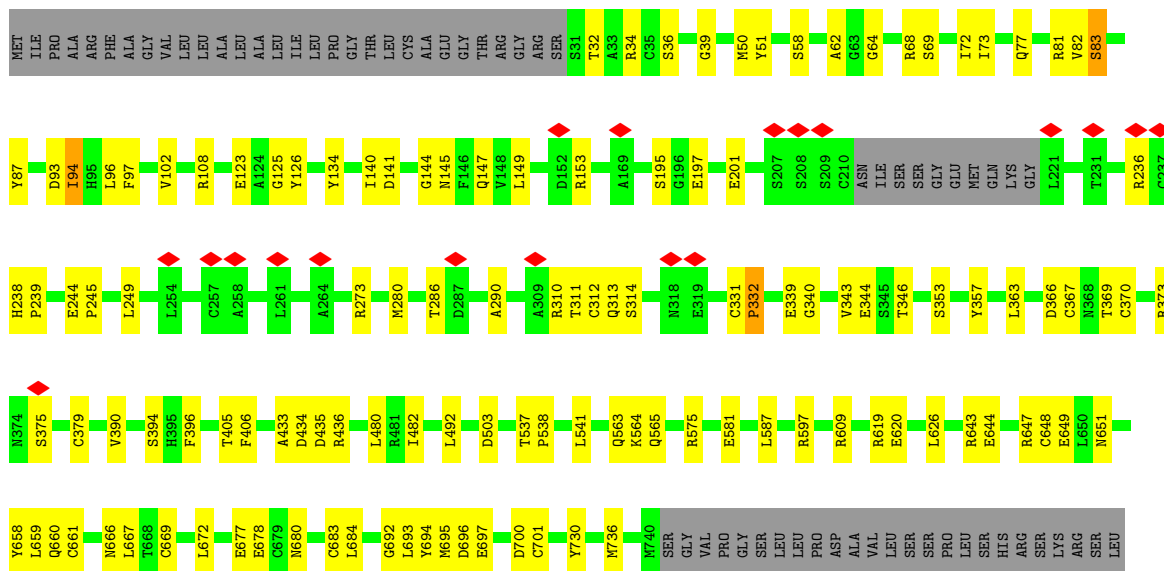
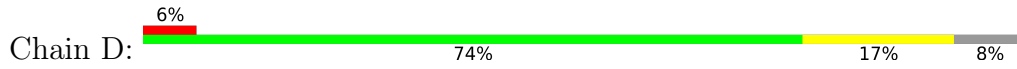

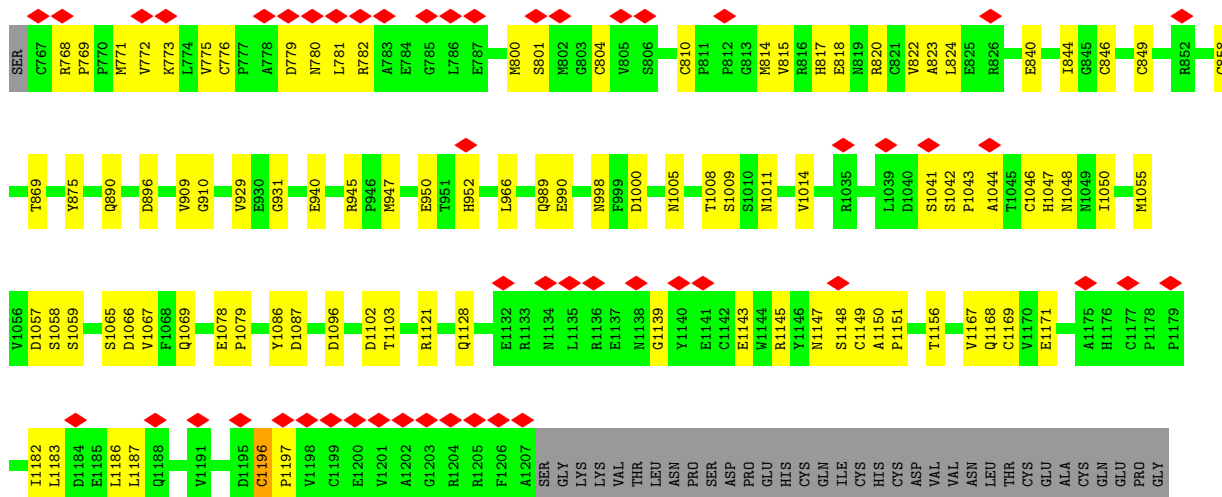

• Molecule 1: von Willebrand factor

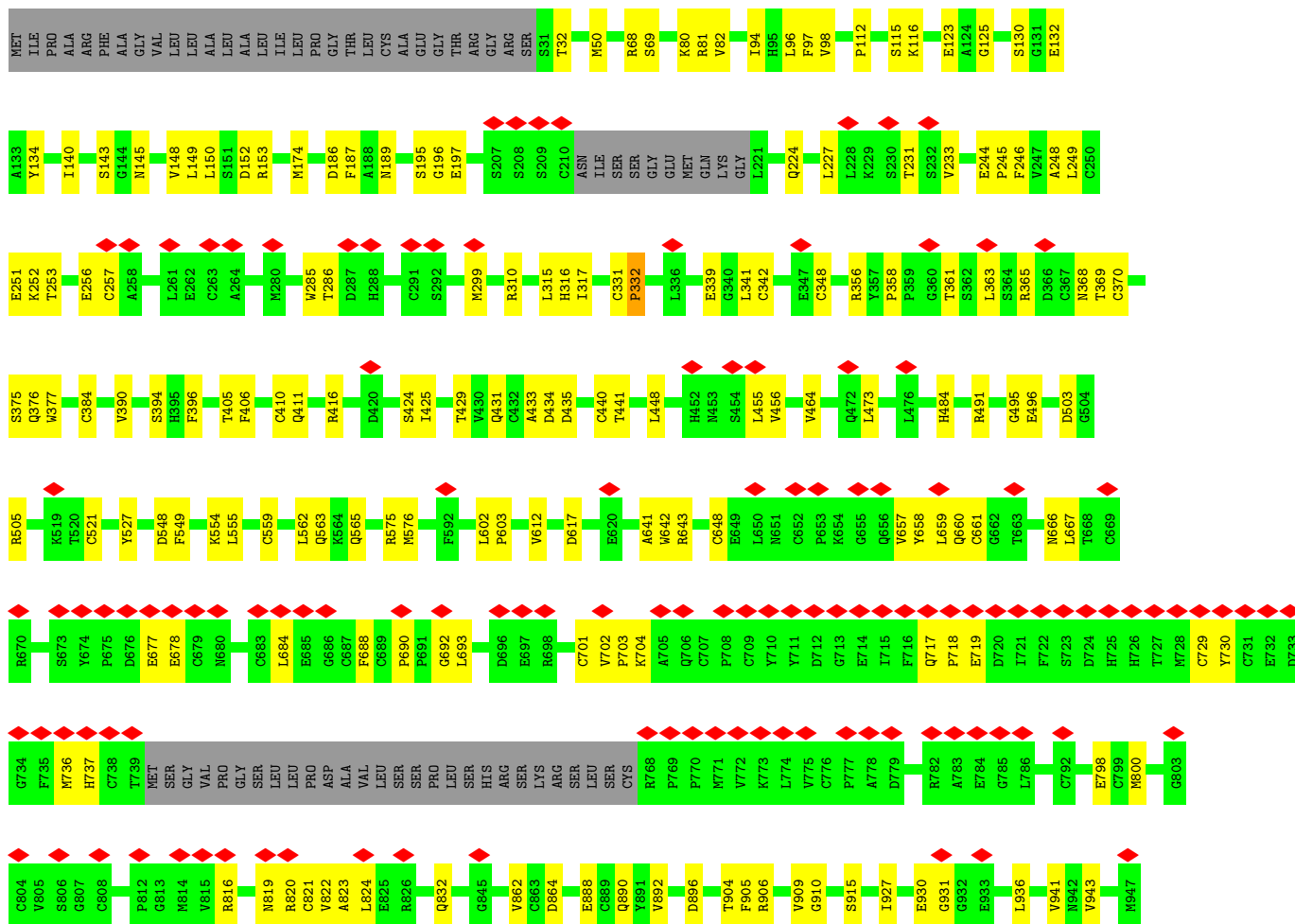
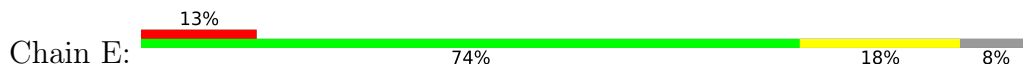

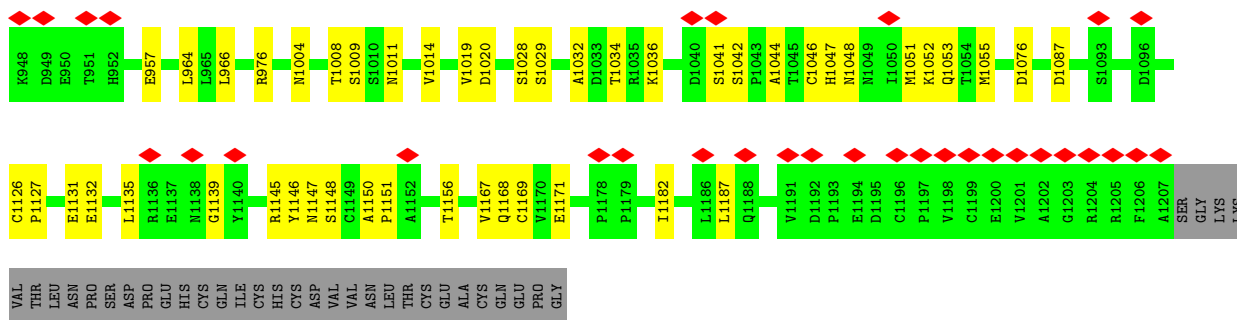

- Molecule 2: beta-D-mannopyranose-(1-4)-2-acetamido-2-deoxy-beta-D-glucopyranose-(1-4)-2-acetamido-2-deoxy-beta-D-glucopyranose

Chain C: 100%

MAG1
MAG2
BMA3

- Molecule 2: beta-D-mannopyranose-(1-4)-2-acetamido-2-deoxy-beta-D-glucopyranose-(1-4)-2-acetamido-2-deoxy-beta-D-glucopyranose

Chain F: 100%

MAG1
MAG2
BMA3

- Molecule 2: beta-D-mannopyranose-(1-4)-2-acetamido-2-deoxy-beta-D-glucopyranose-(1-4)-2-acetamido-2-deoxy-beta-D-glucopyranose

Chain G: 100%

MAG1
MAG2
BMA3

- Molecule 3: 2-acetamido-2-deoxy-beta-D-glucopyranose-(1-4)-2-acetamido-2-deoxy-beta-D-glucopyranose

Chain H: 50% 50%

MAG1
MAG2

4 Experimental information

Property	Value	Source
EM reconstruction method	HELICAL	Depositor
Imposed symmetry	HELICAL, twist=86.0°, rise=28.5 Å, axial sym=D1	Depositor
Number of segments used	88715	Depositor
Resolution determination method	FSC 0.143 CUT-OFF	Depositor
CTF correction method	PHASE FLIPPING AND AMPLITUDE CORRECTION	Depositor
Microscope	FEI TITAN KRIOS	Depositor
Voltage (kV)	300	Depositor
Electron dose ($e^-/\text{Å}^2$)	48	Depositor
Minimum defocus (nm)	Not provided	
Maximum defocus (nm)	Not provided	
Magnification	Not provided	
Image detector	GATAN K3 BIOQUANTUM (6k x 4k)	Depositor
Maximum map value	3.196	Depositor
Minimum map value	-2.512	Depositor
Average map value	-0.000	Depositor
Map value standard deviation	0.058	Depositor
Recommended contour level	0.06	Depositor
Map size (Å)	275.94785, 266.97394, 279.31308	wwPDB
Map dimensions	246, 238, 249	wwPDB
Map angles (°)	90.0, 90.0, 90.0	wwPDB
Pixel spacing (Å)	1.1217393, 1.1217393, 1.1217393	Depositor

5 Model quality [i](#)

5.1 Standard geometry [i](#)

Bond lengths and bond angles in the following residue types are not validated in this section: CA, NAG, BMA

The Z score for a bond length (or angle) is the number of standard deviations the observed value is removed from the expected value. A bond length (or angle) with $|Z| > 5$ is considered an outlier worth inspection. RMSZ is the root-mean-square of all Z scores of the bond lengths (or angles).

Mol	Chain	Bond lengths		Bond angles	
		RMSZ	# Z >5	RMSZ	# Z >5
1	A	0.15	0/8935	0.42	2/12117 (0.0%)
1	B	0.15	0/8946	0.39	0/12132
1	D	0.14	0/8946	0.36	0/12132
1	E	0.13	0/8935	0.37	0/12117
All	All	0.14	0/35762	0.38	2/48498 (0.0%)

Chiral center outliers are detected by calculating the chiral volume of a chiral center and verifying if the center is modelled as a planar moiety or with the opposite hand. A planarity outlier is detected by checking planarity of atoms in a peptide group, atoms in a mainchain group or atoms of a sidechain that are expected to be planar.

Mol	Chain	#Chirality outliers	#Planarity outliers
1	A	0	1
1	D	0	1
All	All	0	2

There are no bond length outliers.

All (2) bond angle outliers are listed below:

Mol	Chain	Res	Type	Atoms	Z	Observed(°)	Ideal(°)
1	A	826	ARG	CA-C-N	-5.50	113.30	120.67
1	A	826	ARG	C-N-CA	-5.50	113.30	120.67

There are no chirality outliers.

All (2) planarity outliers are listed below:

Mol	Chain	Res	Type	Group
1	A	1051	MET	Peptide
1	D	1196	CYS	Peptide

5.2 Too-close contacts [i](#)

In the following table, the Non-H and H(model) columns list the number of non-hydrogen atoms and hydrogen atoms in the chain respectively. The H(added) column lists the number of hydrogen atoms added and optimized by MolProbity. The Clashes column lists the number of clashes within the asymmetric unit, whereas Symm-Clashes lists symmetry-related clashes.

Mol	Chain	Non-H	H(model)	H(added)	Clashes	Symm-Clashes
1	A	8734	8165	8155	168	0
1	B	8745	8171	8160	155	0
1	D	8745	8172	8160	151	0
1	E	8734	8165	8155	151	0
2	C	39	22	34	2	0
2	F	39	22	34	0	0
2	G	39	22	34	0	0
3	H	28	16	25	0	0
4	A	56	32	52	0	0
4	B	56	32	52	2	0
4	D	56	32	52	1	0
4	E	56	32	52	3	0
5	A	3	0	0	0	0
5	B	3	0	0	0	0
5	D	3	0	0	0	0
5	E	3	0	0	0	0
6	B	4	0	0	1	0
All	All	35343	32883	32965	622	0

The all-atom clashscore is defined as the number of clashes found per 1000 atoms (including hydrogen atoms). The all-atom clashscore for this structure is 9.

The worst 5 of 622 close contacts within the same asymmetric unit are listed below, sorted by their clash magnitude.

Atom-1	Atom-2	Interatomic distance (Å)	Clash overlap (Å)
1:A:736:MET:O	1:A:737:HIS:ND1	1.94	1.00
1:B:820:ARG:NH1	1:B:821:CYS:SG	2.34	0.99
1:D:619:ARG:NH2	1:E:196:GLY:O	2.01	0.92
1:A:491:ARG:NH2	1:A:499:GLN:OE1	2.08	0.87
1:B:780:ASN:OD1	1:B:782:ARG:NH1	2.07	0.86

There are no symmetry-related clashes.

5.3 Torsion angles [i](#)

5.3.1 Protein backbone [i](#)

In the following table, the Percentiles column shows the percent Ramachandran outliers of the chain as a percentile score with respect to all PDB entries followed by that with respect to all EM entries.

The Analysed column shows the number of residues for which the backbone conformation was analysed, and the total number of residues.

Mol	Chain	Analysed	Favoured	Allowed	Outliers	Percentiles	
1	A	1135/1241 (92%)	949 (84%)	182 (16%)	4 (0%)	30	60
1	B	1137/1241 (92%)	969 (85%)	166 (15%)	2 (0%)	43	72
1	D	1137/1241 (92%)	979 (86%)	155 (14%)	3 (0%)	36	65
1	E	1135/1241 (92%)	968 (85%)	164 (14%)	3 (0%)	36	65
All	All	4544/4964 (92%)	3865 (85%)	667 (15%)	12 (0%)	37	65

5 of 12 Ramachandran outliers are listed below:

Mol	Chain	Res	Type
1	A	332	PRO
1	B	94	ILE
1	B	332	PRO
1	D	332	PRO
1	E	332	PRO

5.3.2 Protein sidechains [i](#)

In the following table, the Percentiles column shows the percent sidechain outliers of the chain as a percentile score with respect to all PDB entries followed by that with respect to all EM entries.

The Analysed column shows the number of residues for which the sidechain conformation was analysed, and the total number of residues.

Mol	Chain	Analysed	Rotameric	Outliers	Percentiles	
1	A	983/1069 (92%)	983 (100%)	0	100	100
1	B	984/1069 (92%)	984 (100%)	0	100	100
1	D	984/1069 (92%)	984 (100%)	0	100	100
1	E	983/1069 (92%)	982 (100%)	1 (0%)	88	88
All	All	3934/4276 (92%)	3933 (100%)	1 (0%)	100	100

All (1) residues with a non-rotameric sidechain are listed below:

Mol	Chain	Res	Type
1	E	1004	ASN

Sometimes sidechains can be flipped to improve hydrogen bonding and reduce clashes. 5 of 31 such sidechains are listed below:

Mol	Chain	Res	Type
1	B	368	ASN
1	E	288	HIS
1	B	484	HIS
1	E	484	HIS
1	D	277	GLN

5.3.3 RNA [i](#)

There are no RNA molecules in this entry.

5.4 Non-standard residues in protein, DNA, RNA chains [i](#)

There are no non-standard protein/DNA/RNA residues in this entry.

5.5 Carbohydrates [i](#)

11 monosaccharides are modelled in this entry.

In the following table, the Counts columns list the number of bonds (or angles) for which Mogul statistics could be retrieved, the number of bonds (or angles) that are observed in the model and the number of bonds (or angles) that are defined in the Chemical Component Dictionary. The Link column lists molecule types, if any, to which the group is linked. The Z score for a bond length (or angle) is the number of standard deviations the observed value is removed from the expected value. A bond length (or angle) with $|Z| > 2$ is considered an outlier worth inspection. RMSZ is the root-mean-square of all Z scores of the bond lengths (or angles).

Mol	Type	Chain	Res	Link	Bond lengths			Bond angles		
					Counts	RMSZ	$\# Z > 2$	Counts	RMSZ	$\# Z > 2$
2	NAG	C	1	2,1	14,14,15	0.56	0	17,19,21	0.67	0
2	NAG	C	2	2	14,14,15	0.19	0	17,19,21	0.39	0
2	BMA	C	3	2	11,11,12	0.51	0	15,15,17	0.77	0
2	NAG	F	1	2,1	14,14,15	0.22	0	17,19,21	0.41	0
2	NAG	F	2	2	14,14,15	0.17	0	17,19,21	0.45	0
2	BMA	F	3	2	11,11,12	0.51	0	15,15,17	0.69	0
2	NAG	G	1	2,1	14,14,15	0.23	0	17,19,21	0.44	0

Mol	Type	Chain	Res	Link	Bond lengths			Bond angles		
					Counts	RMSZ	# Z > 2	Counts	RMSZ	# Z > 2
2	NAG	G	2	2	14,14,15	0.22	0	17,19,21	0.45	0
2	BMA	G	3	2	11,11,12	0.54	0	15,15,17	0.70	0
3	NAG	H	1	3,1	14,14,15	0.77	1 (7%)	17,19,21	1.28	1 (5%)
3	NAG	H	2	3	14,14,15	0.36	0	17,19,21	0.40	0

In the following table, the Chirals column lists the number of chiral outliers, the number of chiral centers analysed, the number of these observed in the model and the number defined in the Chemical Component Dictionary. Similar counts are reported in the Torsion and Rings columns. '-' means no outliers of that kind were identified.

Mol	Type	Chain	Res	Link	Chirals	Torsions	Rings
2	NAG	C	1	2,1	-	2/6/23/26	0/1/1/1
2	NAG	C	2	2	-	2/6/23/26	0/1/1/1
2	BMA	C	3	2	-	2/2/19/22	0/1/1/1
2	NAG	F	1	2,1	-	2/6/23/26	0/1/1/1
2	NAG	F	2	2	-	4/6/23/26	0/1/1/1
2	BMA	F	3	2	-	0/2/19/22	0/1/1/1
2	NAG	G	1	2,1	-	0/6/23/26	0/1/1/1
2	NAG	G	2	2	-	2/6/23/26	0/1/1/1
2	BMA	G	3	2	-	0/2/19/22	0/1/1/1
3	NAG	H	1	3,1	-	1/6/23/26	0/1/1/1
3	NAG	H	2	3	-	3/6/23/26	0/1/1/1

All (1) bond length outliers are listed below:

Mol	Chain	Res	Type	Atoms	Z	Observed(Å)	Ideal(Å)
3	H	1	NAG	O5-C1	2.61	1.48	1.43

All (1) bond angle outliers are listed below:

Mol	Chain	Res	Type	Atoms	Z	Observed(°)	Ideal(°)
3	H	1	NAG	C1-O5-C5	5.14	119.08	112.19

There are no chirality outliers.

5 of 18 torsion outliers are listed below:

Mol	Chain	Res	Type	Atoms
2	C	2	NAG	O5-C5-C6-O6
2	F	1	NAG	O5-C5-C6-O6

Continued on next page...

Continued from previous page...

Mol	Chain	Res	Type	Atoms
2	C	2	NAG	C4-C5-C6-O6
2	F	2	NAG	C4-C5-C6-O6
2	C	3	BMA	O5-C5-C6-O6

There are no ring outliers.

3 monomers are involved in 2 short contacts:

Mol	Chain	Res	Type	Clashes	Symm-Clashes
2	C	3	BMA	1	0
2	C	2	NAG	2	0
2	C	1	NAG	1	0

The following is a two-dimensional graphical depiction of Mogul quality analysis of bond lengths, bond angles, torsion angles, and ring geometry for oligosaccharide.

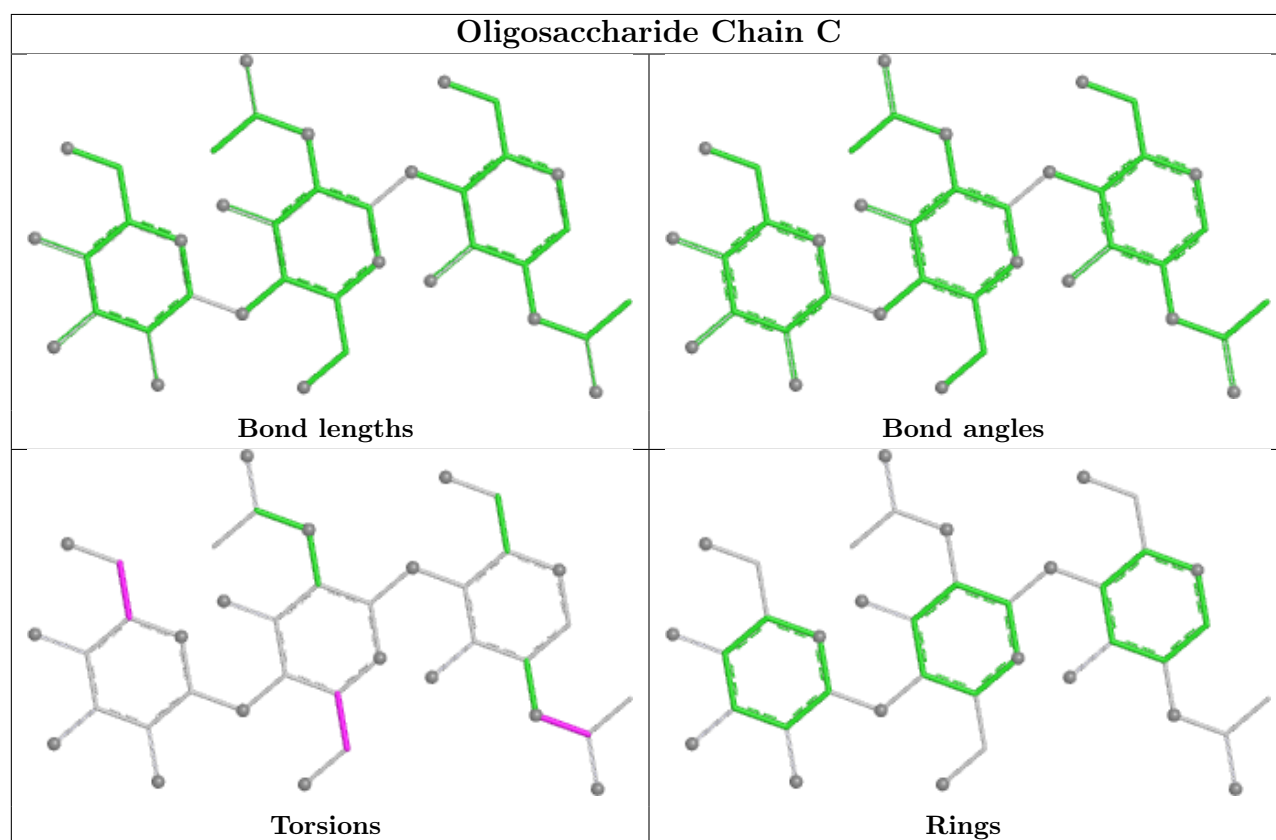

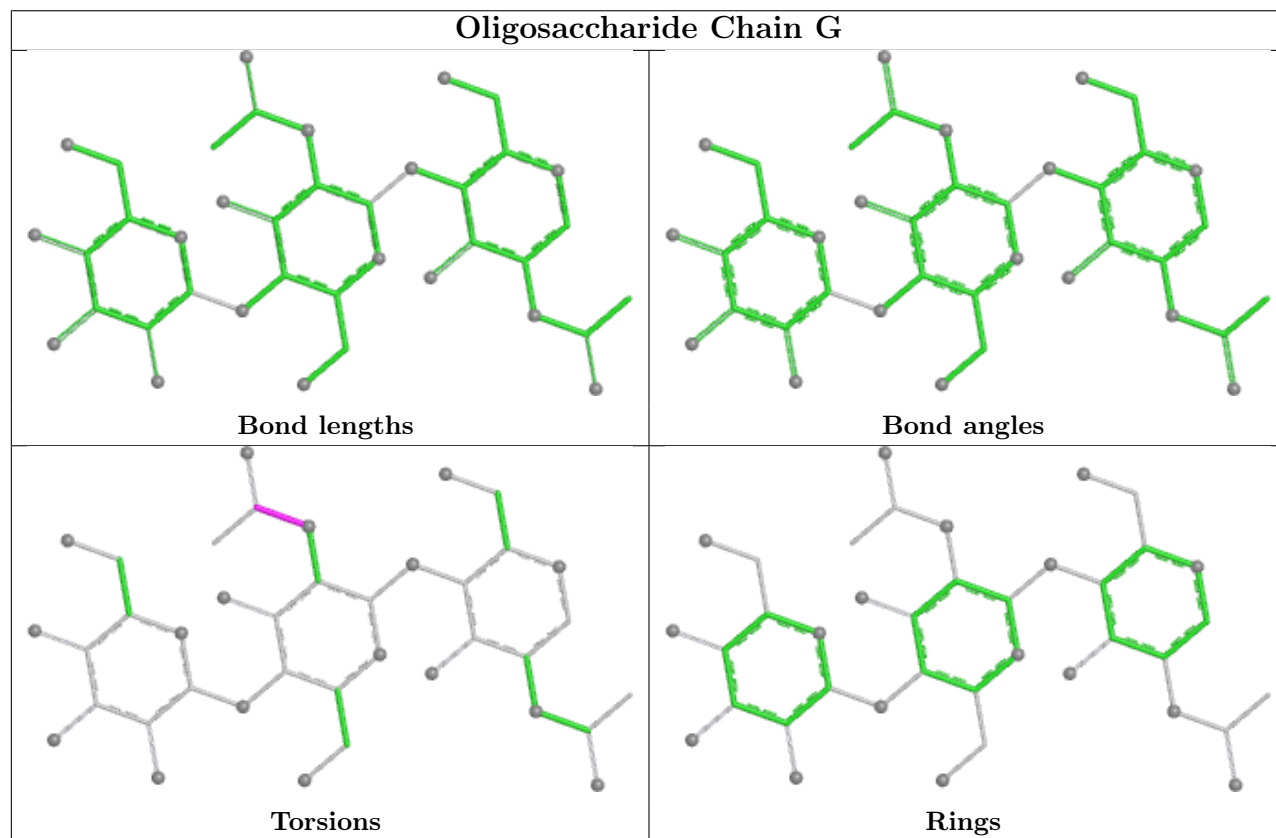
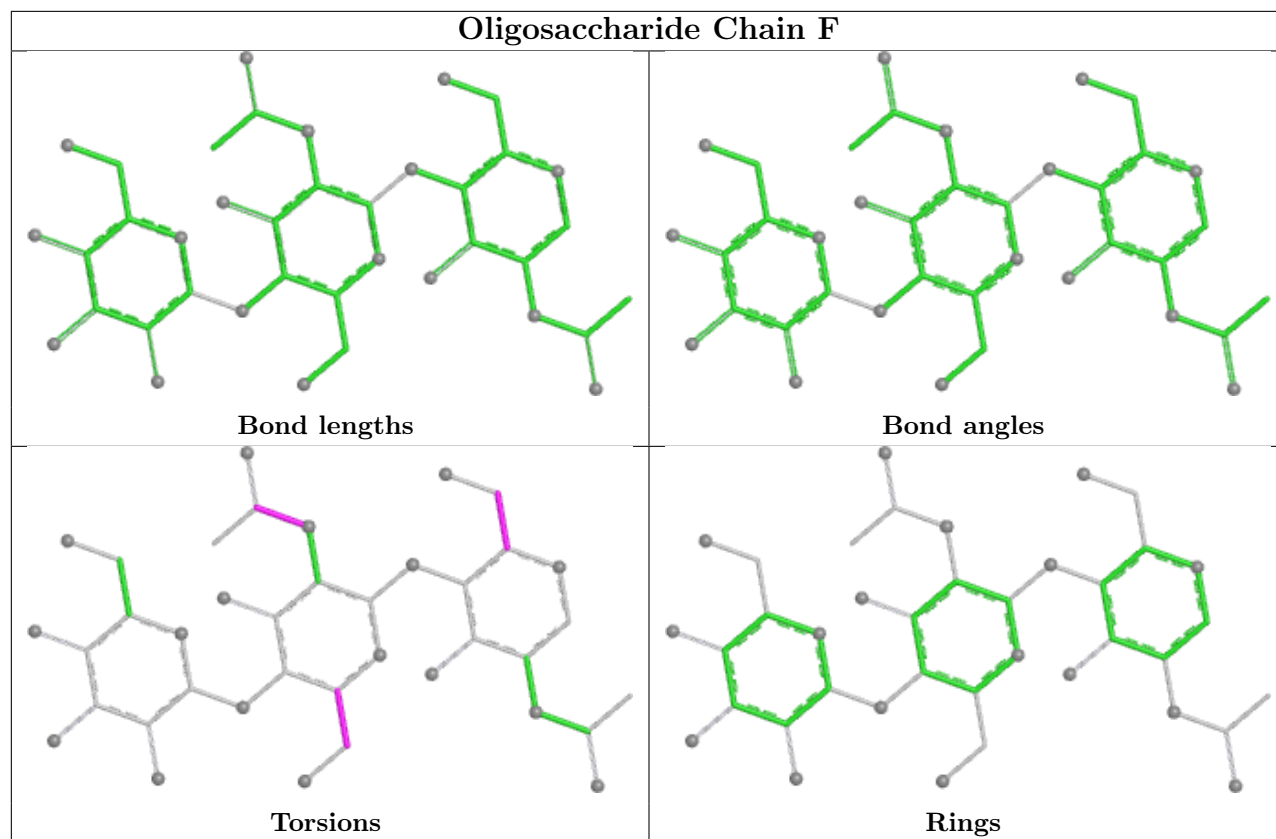

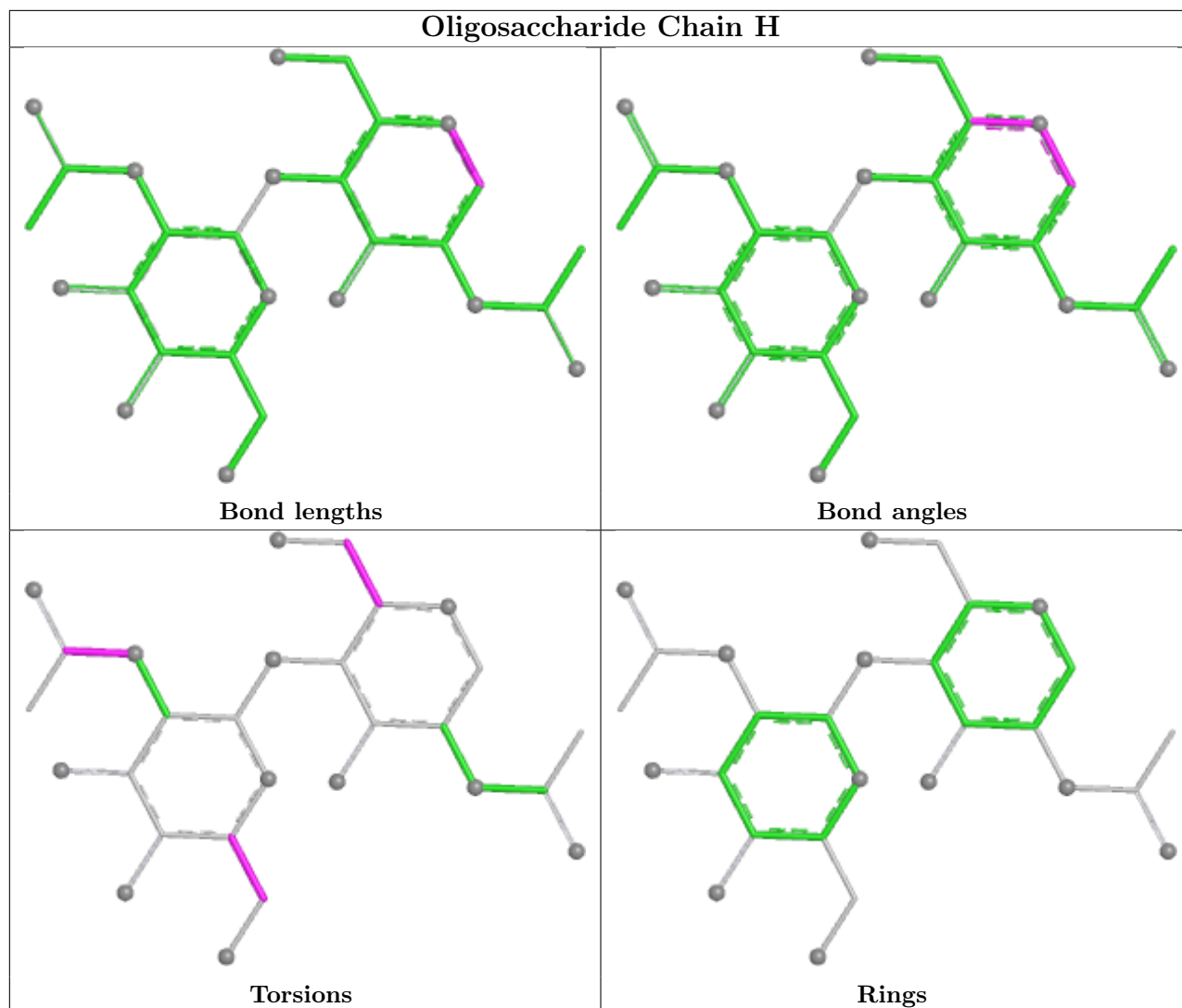

5.6 Ligand geometry [i](#)

Of 28 ligands modelled in this entry, 12 are monoatomic - leaving 16 for Mogul analysis.

In the following table, the Counts columns list the number of bonds (or angles) for which Mogul statistics could be retrieved, the number of bonds (or angles) that are observed in the model and the number of bonds (or angles) that are defined in the Chemical Component Dictionary. The Link column lists molecule types, if any, to which the group is linked. The Z score for a bond length (or angle) is the number of standard deviations the observed value is removed from the expected value. A bond length (or angle) with $|Z| > 2$ is considered an outlier worth inspection. RMSZ is the root-mean-square of all Z scores of the bond lengths (or angles).

Mol	Type	Chain	Res	Link	Bond lengths			Bond angles		
					Counts	RMSZ	$\# Z > 2$	Counts	RMSZ	$\# Z > 2$
4	NAG	B	1303	1	14,14,15	0.21	0	17,19,21	0.40	0
4	NAG	E	1304	1	14,14,15	0.37	0	17,19,21	0.58	0
4	NAG	D	1304	1	14,14,15	0.22	0	17,19,21	0.43	0

Mol	Type	Chain	Res	Link	Bond lengths			Bond angles		
					Counts	RMSZ	# Z > 2	Counts	RMSZ	# Z > 2
4	NAG	A	1303	1	14,14,15	0.19	0	17,19,21	0.46	0
4	NAG	E	1301	1	14,14,15	0.20	0	17,19,21	0.43	0
4	NAG	E	1302	1	14,14,15	0.31	0	17,19,21	0.43	0
4	NAG	D	1303	1	14,14,15	0.19	0	17,19,21	0.42	0
4	NAG	B	1302	1	14,14,15	0.28	0	17,19,21	0.44	0
4	NAG	E	1303	1	14,14,15	0.21	0	17,19,21	0.40	0
4	NAG	A	1304	1	14,14,15	0.54	0	17,19,21	0.81	1 (5%)
4	NAG	D	1301	1	14,14,15	0.20	0	17,19,21	0.45	0
4	NAG	D	1302	1	14,14,15	0.32	0	17,19,21	0.42	0
4	NAG	B	1304	1	14,14,15	0.26	0	17,19,21	0.48	0
4	NAG	A	1301	1	14,14,15	0.19	0	17,19,21	0.45	0
4	NAG	B	1301	1	14,14,15	0.20	0	17,19,21	0.47	0
4	NAG	A	1302	1	14,14,15	0.22	0	17,19,21	0.46	0

In the following table, the Chirals column lists the number of chiral outliers, the number of chiral centers analysed, the number of these observed in the model and the number defined in the Chemical Component Dictionary. Similar counts are reported in the Torsion and Rings columns. '-' means no outliers of that kind were identified.

Mol	Type	Chain	Res	Link	Chirals	Torsions	Rings
4	NAG	B	1303	1	-	2/6/23/26	0/1/1/1
4	NAG	E	1304	1	-	3/6/23/26	0/1/1/1
4	NAG	D	1304	1	-	4/6/23/26	0/1/1/1
4	NAG	A	1303	1	-	2/6/23/26	0/1/1/1
4	NAG	E	1301	1	-	2/6/23/26	0/1/1/1
4	NAG	E	1302	1	-	0/6/23/26	0/1/1/1
4	NAG	D	1303	1	-	2/6/23/26	0/1/1/1
4	NAG	B	1302	1	-	2/6/23/26	0/1/1/1
4	NAG	E	1303	1	-	0/6/23/26	0/1/1/1
4	NAG	A	1304	1	-	3/6/23/26	0/1/1/1
4	NAG	D	1301	1	-	0/6/23/26	0/1/1/1
4	NAG	D	1302	1	-	2/6/23/26	0/1/1/1
4	NAG	B	1304	1	-	1/6/23/26	0/1/1/1
4	NAG	A	1301	1	-	0/6/23/26	0/1/1/1
4	NAG	B	1301	1	-	2/6/23/26	0/1/1/1
4	NAG	A	1302	1	-	2/6/23/26	0/1/1/1

There are no bond length outliers.

All (1) bond angle outliers are listed below:

Mol	Chain	Res	Type	Atoms	Z	Observed(°)	Ideal(°)
4	A	1304	NAG	C1-O5-C5	2.99	116.19	112.19

There are no chirality outliers.

5 of 27 torsion outliers are listed below:

Mol	Chain	Res	Type	Atoms
4	D	1304	NAG	C4-C5-C6-O6
4	B	1303	NAG	O5-C5-C6-O6
4	D	1304	NAG	O5-C5-C6-O6
4	A	1304	NAG	C4-C5-C6-O6
4	A	1303	NAG	O5-C5-C6-O6

There are no ring outliers.

5 monomers are involved in 6 short contacts:

Mol	Chain	Res	Type	Clashes	Symm-Clashes
4	E	1304	NAG	2	0
4	E	1302	NAG	1	0
4	B	1302	NAG	1	0
4	D	1302	NAG	1	0
4	B	1304	NAG	1	0

5.7 Other polymers [i](#)

There are no such residues in this entry.

5.8 Polymer linkage issues [i](#)

There are no chain breaks in this entry.

6 Map visualisation [i](#)

This section contains visualisations of the EMDB entry EMD-13541. These allow visual inspection of the internal detail of the map and identification of artifacts.

No raw map or half-maps were deposited for this entry and therefore no images, graphs, etc. pertaining to the raw map can be shown.

6.1 Orthogonal projections [i](#)

6.1.1 Primary map

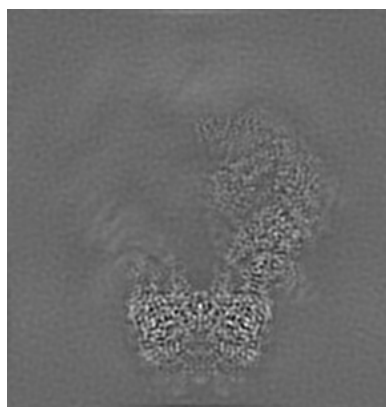

X

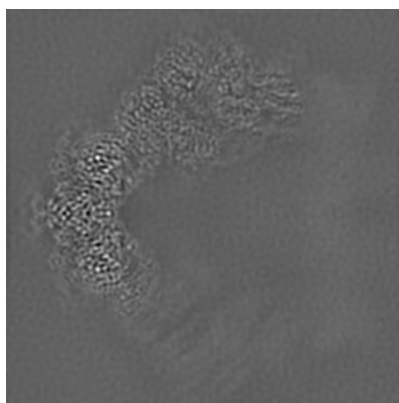

Y

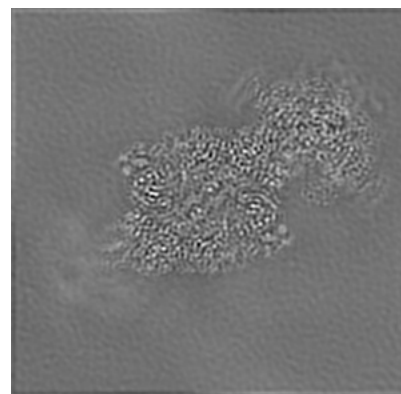

Z

The images above show the map projected in three orthogonal directions.

6.2 Central slices [i](#)

6.2.1 Primary map

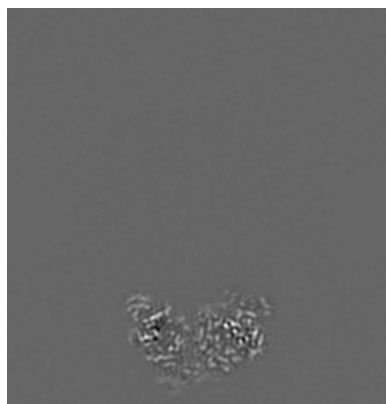

X Index: 123

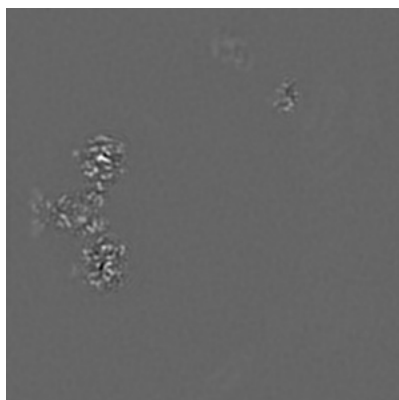

Y Index: 119

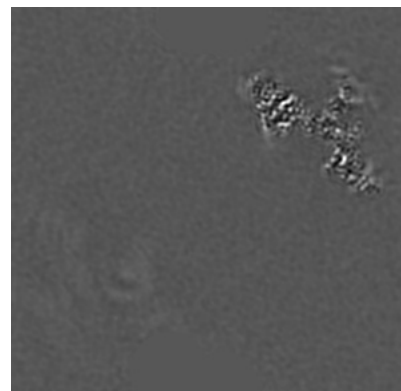

Z Index: 124

The images above show central slices of the map in three orthogonal directions.

6.3 Largest variance slices [i](#)

6.3.1 Primary map

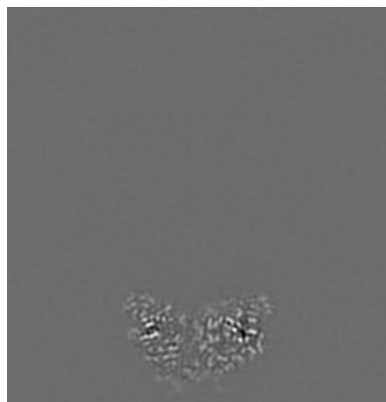

X Index: 122

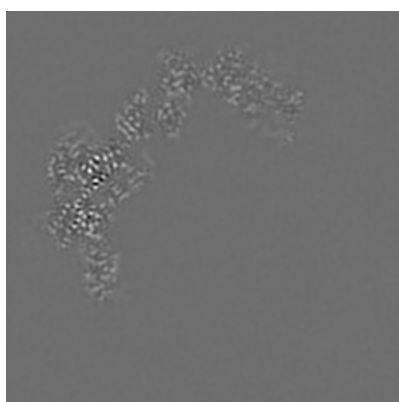

Y Index: 148

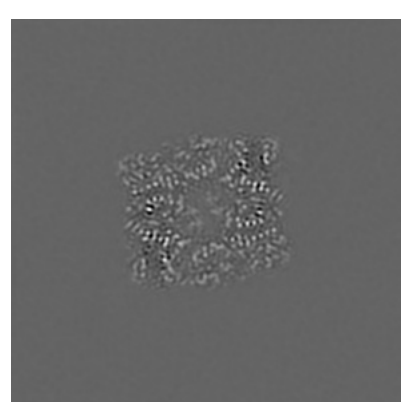

Z Index: 59

The images above show the largest variance slices of the map in three orthogonal directions.

6.4 Orthogonal standard-deviation projections (False-color) [i](#)

6.4.1 Primary map

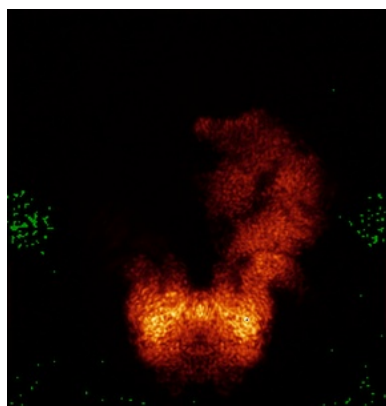

X

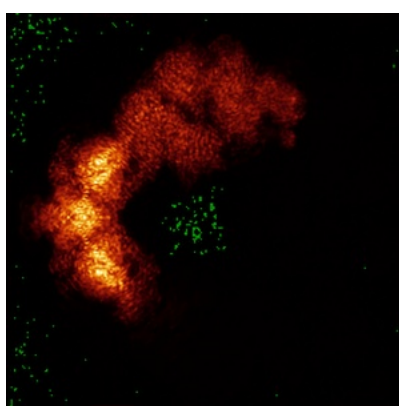

Y

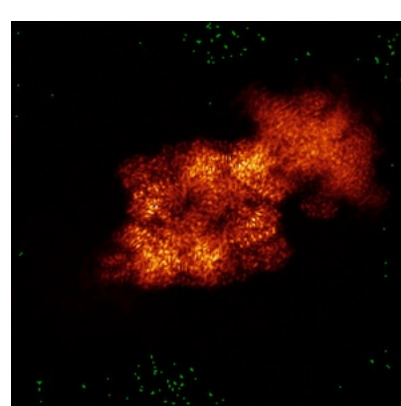

Z

The images above show the map standard deviation projections with false color in three orthogonal directions. Minimum values are shown in green, max in blue, and dark to light orange shades represent small to large values respectively.

6.5 Orthogonal surface views [i](#)

6.5.1 Primary map

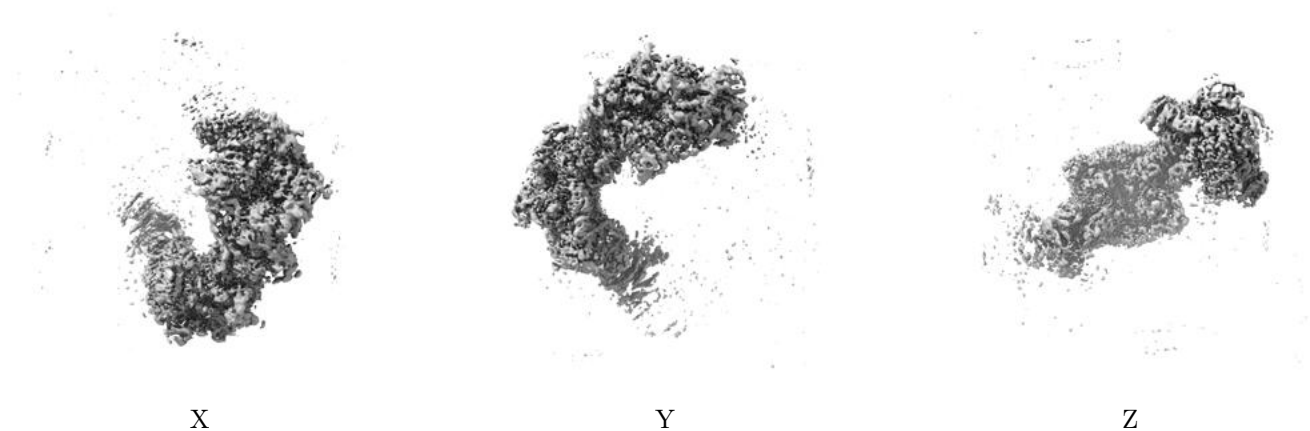

The images above show the 3D surface view of the map at the recommended contour level 0.06. These images, in conjunction with the slice images, may facilitate assessment of whether an appropriate contour level has been provided.

6.6 Mask visualisation [i](#)

This section was not generated. No masks/segmentation were deposited.

7 Map analysis [i](#)

This section contains the results of statistical analysis of the map.

7.1 Map-value distribution [i](#)

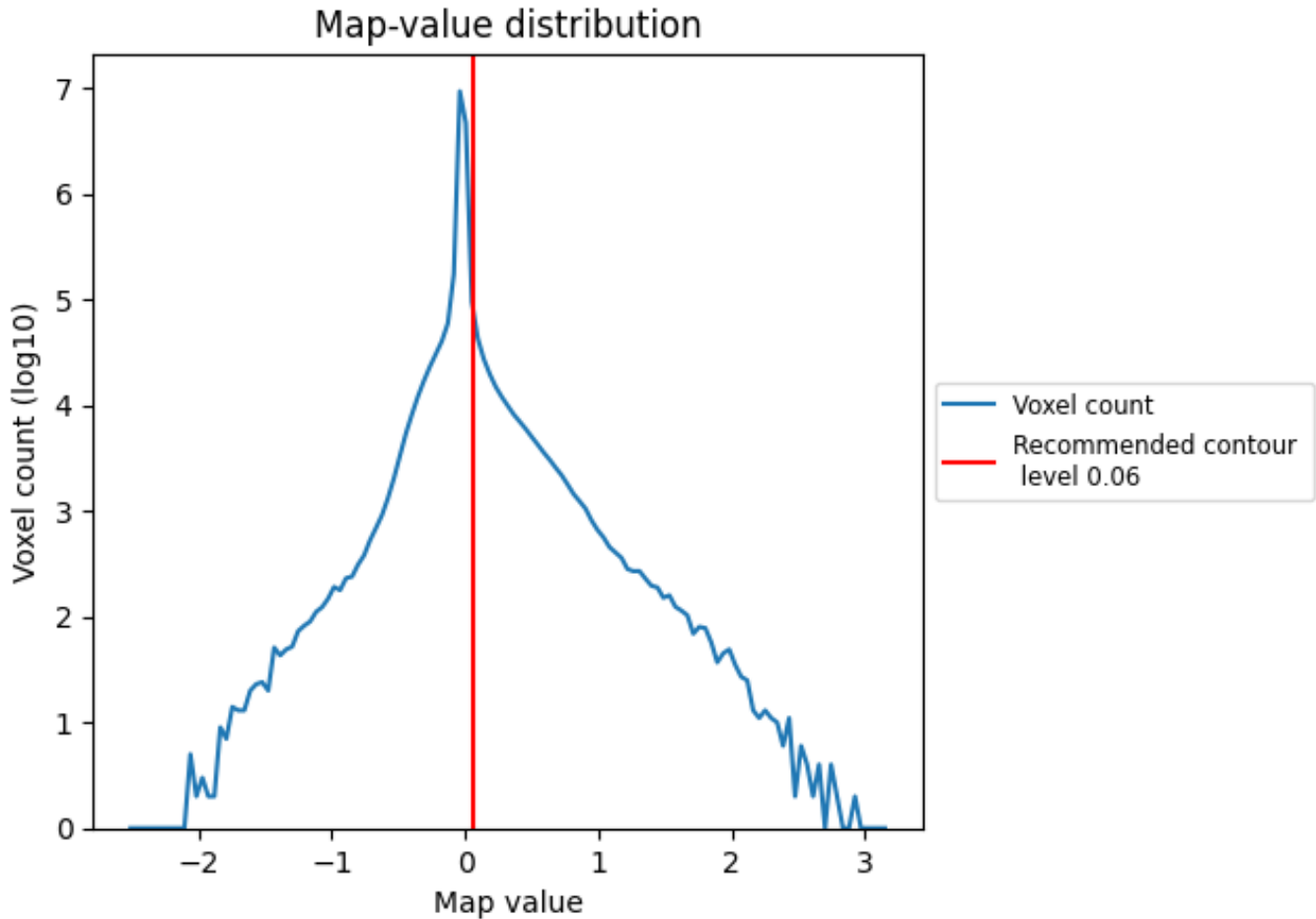

The map-value distribution is plotted in 128 intervals along the x-axis. The y-axis is logarithmic. A spike in this graph at zero usually indicates that the volume has been masked.

7.2 Volume estimate [i](#)

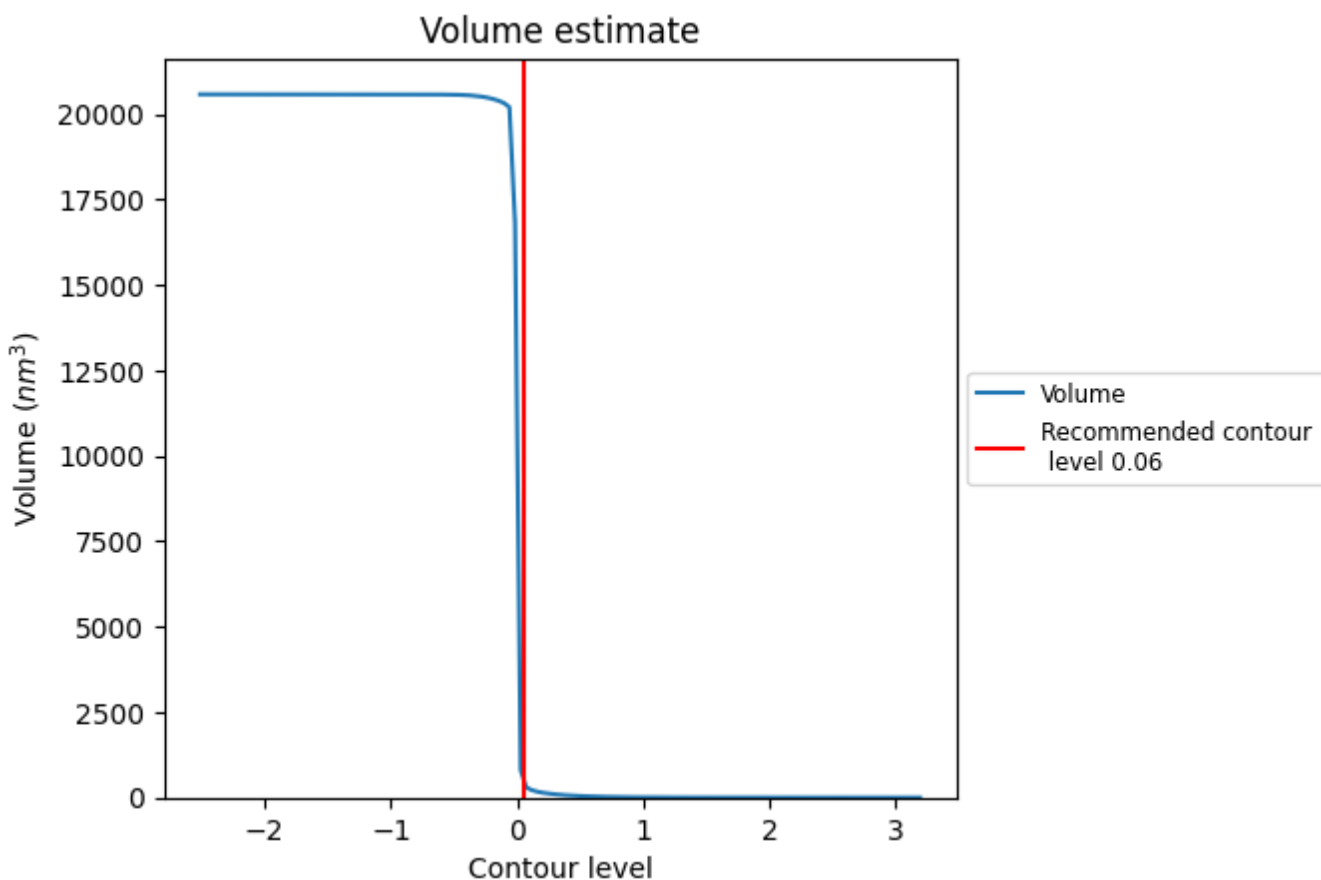

The volume at the recommended contour level is 461 nm³; this corresponds to an approximate mass of 417 kDa.

The volume estimate graph shows how the enclosed volume varies with the contour level. The recommended contour level is shown as a vertical line and the intersection between the line and the curve gives the volume of the enclosed surface at the given level.

7.3 Rotationally averaged power spectrum [i](#)

This section was not generated. The rotationally averaged power spectrum is only generated for cubic maps.

8 Fourier-Shell correlation [i](#)

Fourier-Shell Correlation (FSC) is the most commonly used method to estimate the resolution of single-particle and subtomogram-averaged maps. The shape of the curve depends on the imposed symmetry, mask and whether or not the two 3D reconstructions used were processed from a common reference. The reported resolution is shown as a black line. A curve is displayed for the half-bit criterion in addition to lines showing the 0.143 gold standard cut-off and 0.5 cut-off.

8.1 FSC [i](#)

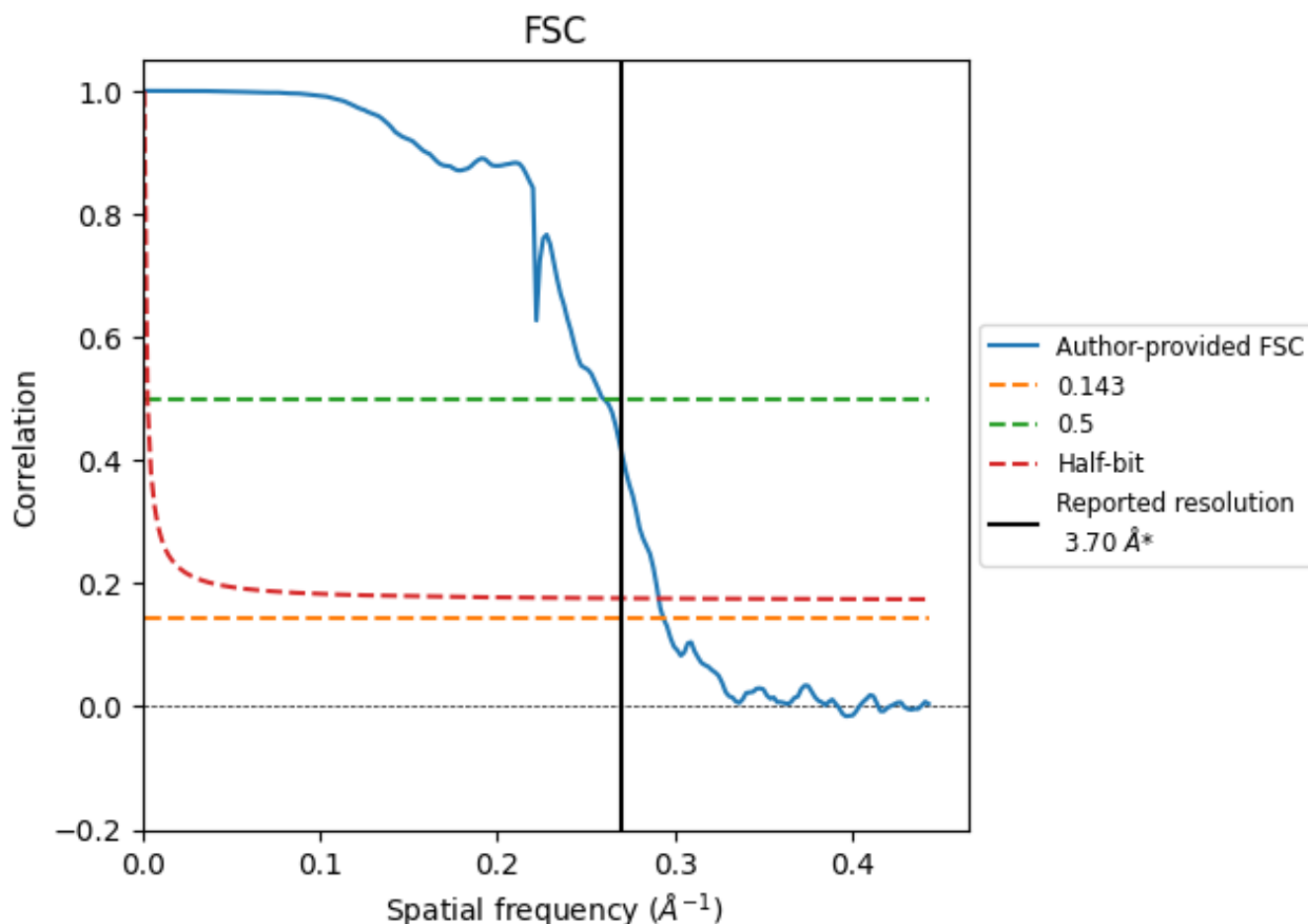

*Reported resolution corresponds to spatial frequency of 0.270 Å⁻¹

8.2 Resolution estimates [i](#)

Resolution estimate (Å)	Estimation criterion (FSC cut-off)		
	0.143	0.5	Half-bit
Reported by author	3.70	-	-
Author-provided FSC curve	3.41	3.85	3.44
Unmasked-calculated*	-	-	-

*Resolution estimate based on FSC curve calculated by comparison of deposited half-maps.

9 Map-model fit [i](#)

This section contains information regarding the fit between EMDB map EMD-13541 and PDB model 7PMV. Per-residue inclusion information can be found in section [3](#) on page [7](#).

9.1 Map-model overlay [i](#)

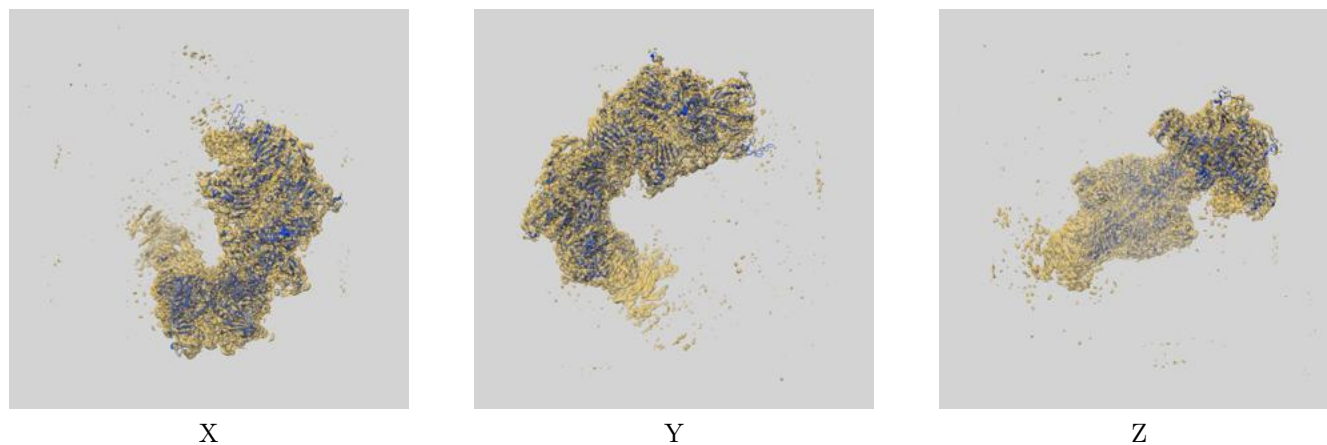

The images above show the 3D surface view of the map at the recommended contour level 0.06 at 50% transparency in yellow overlaid with a ribbon representation of the model coloured in blue. These images allow for the visual assessment of the quality of fit between the atomic model and the map.

9.2 Q-score mapped to coordinate model [i](#)

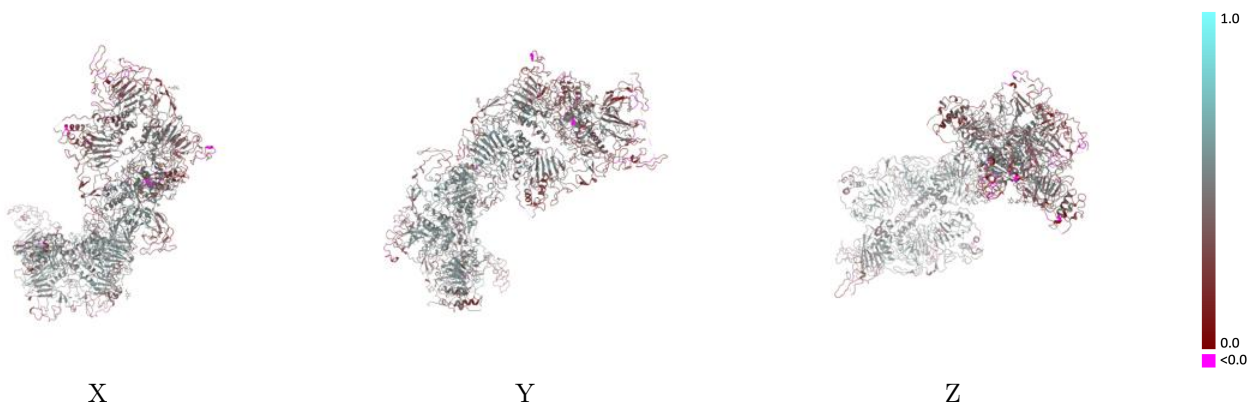

The images above show the model with each residue coloured according its Q-score. This shows their resolvability in the map with higher Q-score values reflecting better resolvability. Please note: Q-score is calculating the resolvability of atoms, and thus high values are only expected at resolutions at which atoms can be resolved. Low Q-score values may therefore be expected for many entries.

9.3 Atom inclusion mapped to coordinate model [i](#)

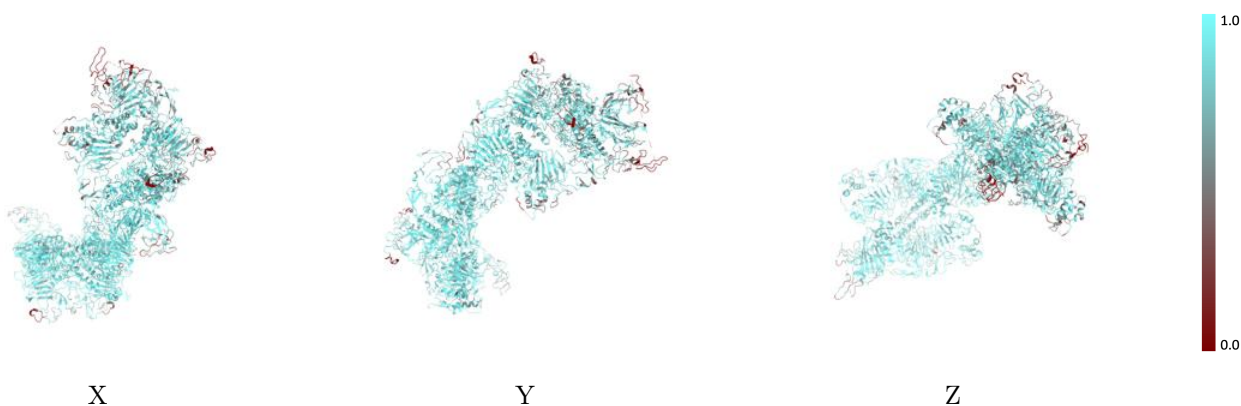

The images above show the model with each residue coloured according to its atom inclusion. This shows to what extent they are inside the map at the recommended contour level (0.06).



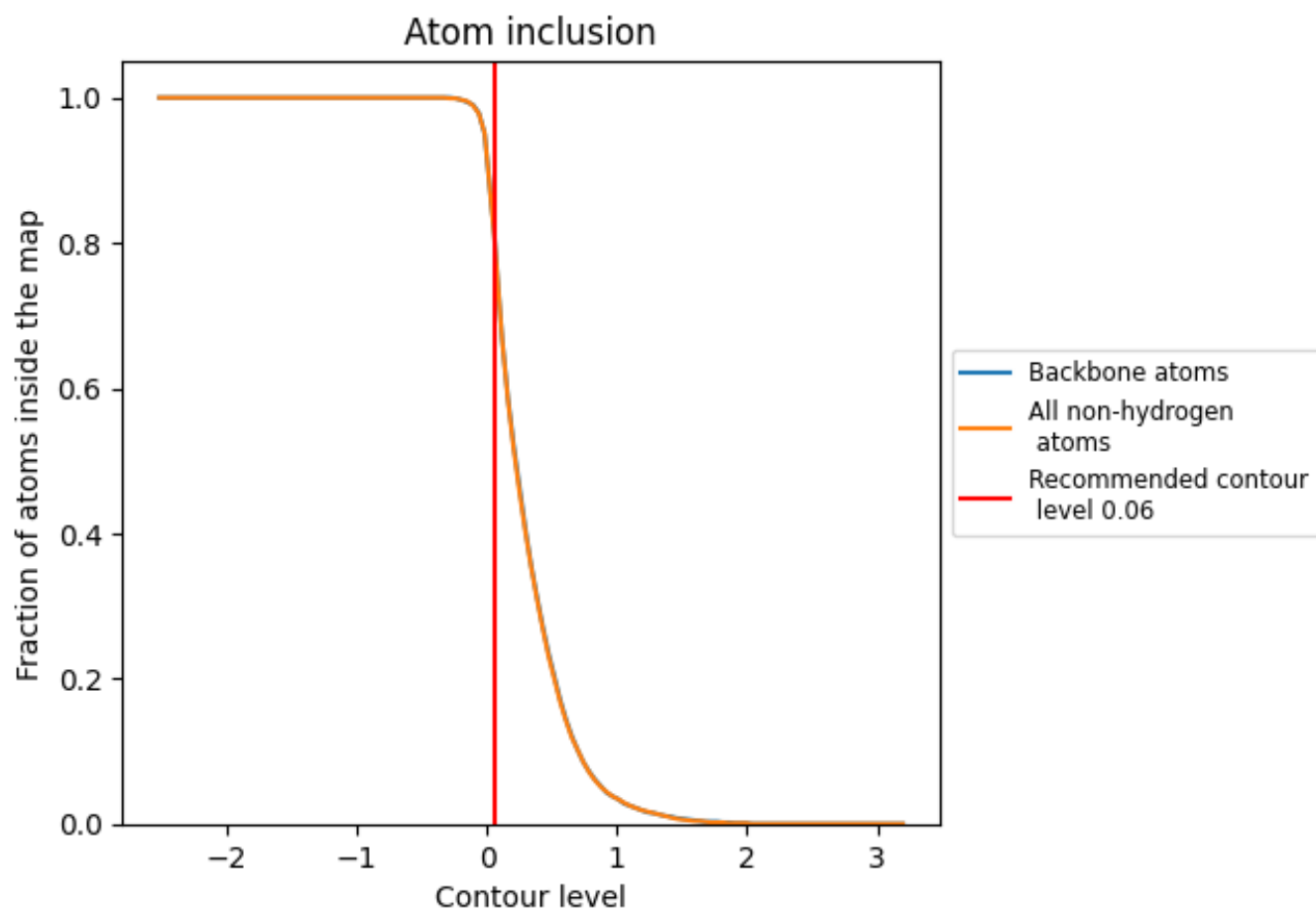















9.4 Atom inclusion [i](#)



At the recommended contour level, 81% of all backbone atoms, 81% of all non-hydrogen atoms, are inside the map.

9.5 Map-model fit summary

The table lists the average atom inclusion at the recommended contour level (0.06) and Q-score for the entire model and for each chain.

Chain	Atom inclusion	Q-score
All	 0.8080	 0.4140
A	 0.8530	 0.4400
B	 0.8770	 0.4600
C	 0.8720	 0.3310
D	 0.8070	 0.4060
E	 0.7080	 0.3500
F	 0.8970	 0.4680
G	 0.6410	 0.3670
H	 0.7140	 0.3060

