



wwPDB X-ray Structure Validation Summary Report ⓘ

Mar 8, 2026 – 02:08 PM UTC

PDB ID : 8SPH / pdb_00008sph
Title : Crystal structure of chimeric omicron RBD (strain XBB.1) complexed with human ACE2
Authors : Zhang, W.; Shi, K.; Aihara, H.; Li, F.
Deposited on : 2023-05-03
Resolution : 2.71 Å(reported)

This is a wwPDB X-ray Structure Validation Summary Report for a publicly released PDB entry.

We welcome your comments at validation@mail.wwpdb.org

A user guide is available at

<https://www.wwpdb.org/validation/2017/XrayValidationReportHelp>

with specific help available everywhere you see the ⓘ symbol.

The types of validation reports are described at

<http://www.wwpdb.org/validation/2017/FAQs#types>.

The following versions of software and data (see [references ⓘ](#)) were used in the production of this report:

MolProbity : 4-5-2 with Phenix2.0
Mogul : 2022.3.0, CSD as543be (2022)
Xtriage (Phenix) : 2.0
EDS : 3.0
Percentile statistics : 20250101.v01 (using entries in the PDB archive January 1st 2025)
CCP4 : 9.0.010 (Gargrove)
Density-Fitness : 1.0.12
Ideal geometry (proteins) : Engh & Huber (2001)
Ideal geometry (DNA, RNA) : Parkinson et al. (1996)
Validation Pipeline (wwPDB-VP) : 2.49

1 Overall quality at a glance i

The following experimental techniques were used to determine the structure:

X-RAY DIFFRACTION

The reported resolution of this entry is 2.71 Å.

Percentile scores (ranging between 0-100) for global validation metrics of the entry are shown in the following graphic. The table shows the number of entries on which the scores are based.

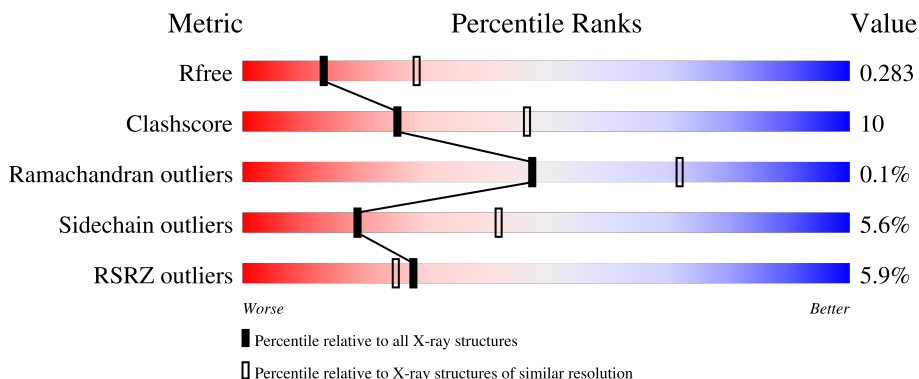

Metric	Whole archive (#Entries)	Similar resolution (#Entries, resolution range(Å))
R_{free}	180053	4348 (2.74-2.70)
Clashscore	190562	4665 (2.74-2.70)
Ramachandran outliers	187476	4584 (2.74-2.70)
Sidechain outliers	187428	4585 (2.74-2.70)
RSRZ outliers	180081	4348 (2.74-2.70)

The table below summarises the geometric issues observed across the polymeric chains and their fit to the electron density. The red, orange, yellow and green segments of the lower bar indicate the fraction of residues that contain outliers for ≥ 3 , 2, 1 and 0 types of geometric quality criteria respectively. A grey segment represents the fraction of residues that are not modelled. The numeric value for each fraction is indicated below the corresponding segment, with a dot representing fractions $\leq 5\%$. The upper red bar (where present) indicates the fraction of residues that have poor fit to the electron density. The numeric value is given above the bar.

Mol	Chain	Length	Quality of chain
1	A	597	5% (Poor fit), 75% (0 outliers), 24% (1 outlier), 0% (2 outliers), 0% (3+ outliers)
1	B	597	6% (Poor fit), 74% (0 outliers), 24% (1 outlier), 0% (2 outliers), 0% (3+ outliers)
2	E	217	8% (Poor fit), 63% (0 outliers), 24% (1 outlier), 0% (2 outliers), 11% (Not modelled)
2	F	217	7% (Poor fit), 58% (0 outliers), 30% (1 outlier), 0% (2 outliers), 11% (Not modelled)
3	C	3	67% (0 outliers), 33% (1 outlier)

Continued on next page...

Continued from previous page...

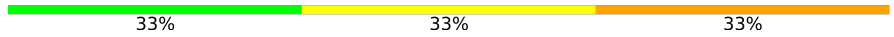
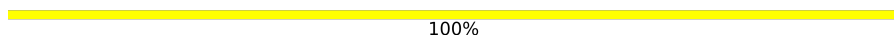
Mol	Chain	Length	Quality of chain
3	L	3	 33% 33% 33%
4	D	2	 50% 50%
4	G	2	 100%
4	H	2	 100%
4	I	2	 100%
4	K	2	 50% 50%
4	M	2	 50% 50%
5	J	4	 50% 50%

The following table lists non-polymeric compounds, carbohydrate monomers and non-standard residues in protein, DNA, RNA chains that are outliers for geometric or electron-density-fit criteria:

Mol	Type	Chain	Res	Chirality	Geometry	Clashes	Electron density
7	CL	B	702	-	-	X	-

2 Entry composition [i](#)

There are 10 unique types of molecules in this entry. The entry contains 13162 atoms, of which 0 are hydrogens and 0 are deuteriums.

In the tables below, the ZeroOcc column contains the number of atoms modelled with zero occupancy, the AltConf column contains the number of residues with at least one atom in alternate conformation and the Trace column contains the number of residues modelled with at most 2 atoms.

- Molecule 1 is a protein called Angiotensin-converting enzyme 2.

Mol	Chain	Residues	Atoms					ZeroOcc	AltConf	Trace
			Total	C	N	O	S			
1	A	596	4862	3111	805	917	29	0	0	0
1	B	596	4862	3111	805	917	29	0	0	0

- Molecule 2 is a protein called Spike protein S1.

Mol	Chain	Residues	Atoms					ZeroOcc	AltConf	Trace
			Total	C	N	O	S			
2	E	193	1522	977	252	284	9	0	0	0
2	F	194	1526	978	253	286	9	0	0	0

- Molecule 3 is an oligosaccharide called beta-D-mannopyranose-(1-4)-2-acetamido-2-deoxy-beta-D-glucopyranose-(1-4)-2-acetamido-2-deoxy-beta-D-glucopyranose.

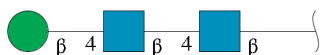

Mol	Chain	Residues	Atoms				ZeroOcc	AltConf	Trace
			Total	C	N	O			
3	C	3	39	22	2	15	0	0	0
3	L	3	39	22	2	15	0	0	0

- Molecule 4 is an oligosaccharide called 2-acetamido-2-deoxy-beta-D-glucopyranose-(1-4)-2-acetamido-2-deoxy-beta-D-glucopyranose.



Mol	Chain	Residues	Atoms				ZeroOcc	AltConf	Trace
4	D	2	Total	C	N	O	0	0	0
			28	16	2	10			
4	G	2	Total	C	N	O	0	0	0
			28	16	2	10			
4	H	2	Total	C	N	O	0	0	0
			28	16	2	10			
4	I	2	Total	C	N	O	0	0	0
			28	16	2	10			
4	K	2	Total	C	N	O	0	0	0
			28	16	2	10			
4	M	2	Total	C	N	O	0	0	0
			28	16	2	10			

- Molecule 5 is an oligosaccharide called 2-acetamido-2-deoxy-beta-D-glucopyranose-(1-3)-beta-D-mannopyranose-(1-4)-2-acetamido-2-deoxy-beta-D-glucopyranose-(1-4)-2-acetamido-2-deoxy-beta-D-glucopyranose.



Mol	Chain	Residues	Atoms				ZeroOcc	AltConf	Trace
5	J	4	Total	C	N	O	0	0	0
			53	30	3	20			

- Molecule 6 is ZINC ION (CCD ID: ZN) (formula: Zn).

Mol	Chain	Residues	Atoms		ZeroOcc	AltConf
6	A	1	Total	Zn	0	0
			1	1		
6	B	1	Total	Zn	0	0
			1	1		

- Molecule 7 is CHLORIDE ION (CCD ID: CL) (formula: Cl).

Mol	Chain	Residues	Atoms		ZeroOcc	AltConf
7	A	1	Total	Cl	0	0
			1	1		
7	B	1	Total	Cl	0	0
			1	1		

- Molecule 8 is 1,2-ETHANEDIOL (CCD ID: EDO) (formula: C₂H₆O₂).



Mol	Chain	Residues	Atoms	ZeroOcc	AltConf
8	A	1	Total C O 4 2 2	0	0
8	B	1	Total C O 4 2 2	0	0
8	B	1	Total C O 4 2 2	0	0
8	B	1	Total C O 4 2 2	0	0

- Molecule 9 is 2-acetamido-2-deoxy-beta-D-glucopyranose (CCD ID: NAG) (formula: $C_8H_{15}NO_6$).



Mol	Chain	Residues	Atoms				ZeroOcc	AltConf
9	A	1	Total	C	N	O	0	0
			14	8	1	5		
9	B	1	Total	C	N	O	0	0
			14	8	1	5		
9	B	1	Total	C	N	O	0	0
			14	8	1	5		

- Molecule 10 is water.

Mol	Chain	Residues	Atoms		ZeroOcc	AltConf
10	A	14	Total	O	0	0
			14	14		
10	B	8	Total	O	0	0
			8	8		
10	E	6	Total	O	0	0
			6	6		
10	F	1	Total	O	0	0
			1	1		

3 Residue-property plots [i](#)

These plots are drawn for all protein, RNA, DNA and oligosaccharide chains in the entry. The first graphic for a chain summarises the proportions of the various outlier classes displayed in the second graphic. The second graphic shows the sequence view annotated by issues in geometry and electron density. Residues are color-coded according to the number of geometric quality criteria for which they contain at least one outlier: green = 0, yellow = 1, orange = 2 and red = 3 or more. A red dot above a residue indicates a poor fit to the electron density ($RSRZ > 2$). Stretches of 2 or more consecutive residues without any outlier are shown as a green connector. Residues present in the sample, but not in the model, are shown in grey.

- Molecule 1: Angiotensin-converting enzyme 2

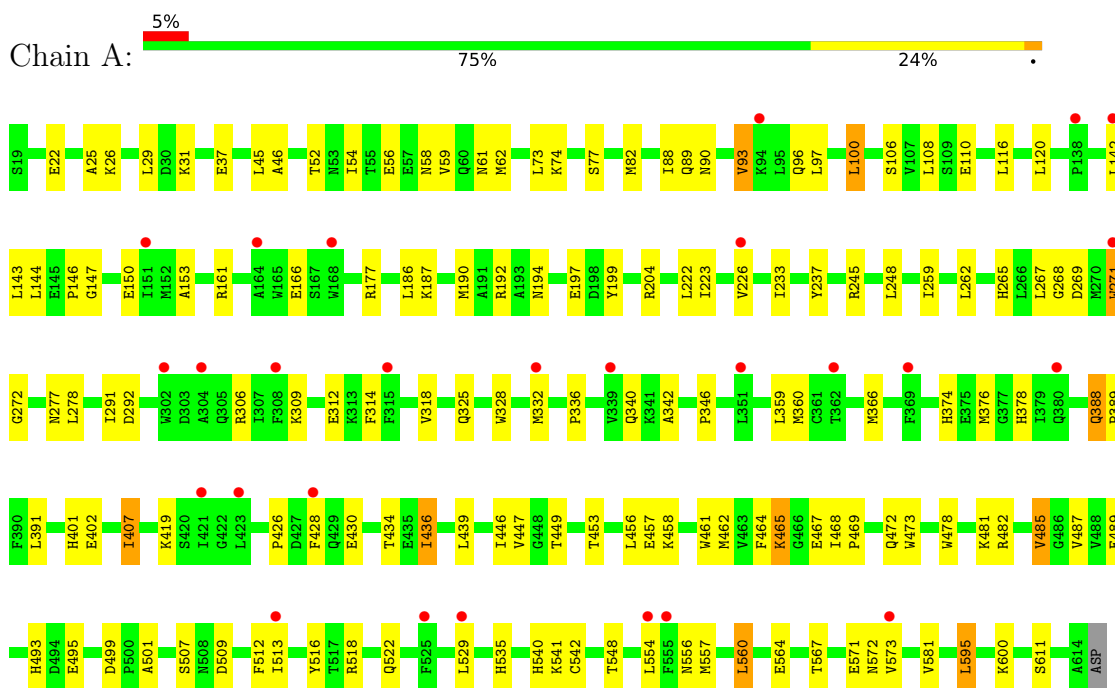

- Molecule 1: Angiotensin-converting enzyme 2

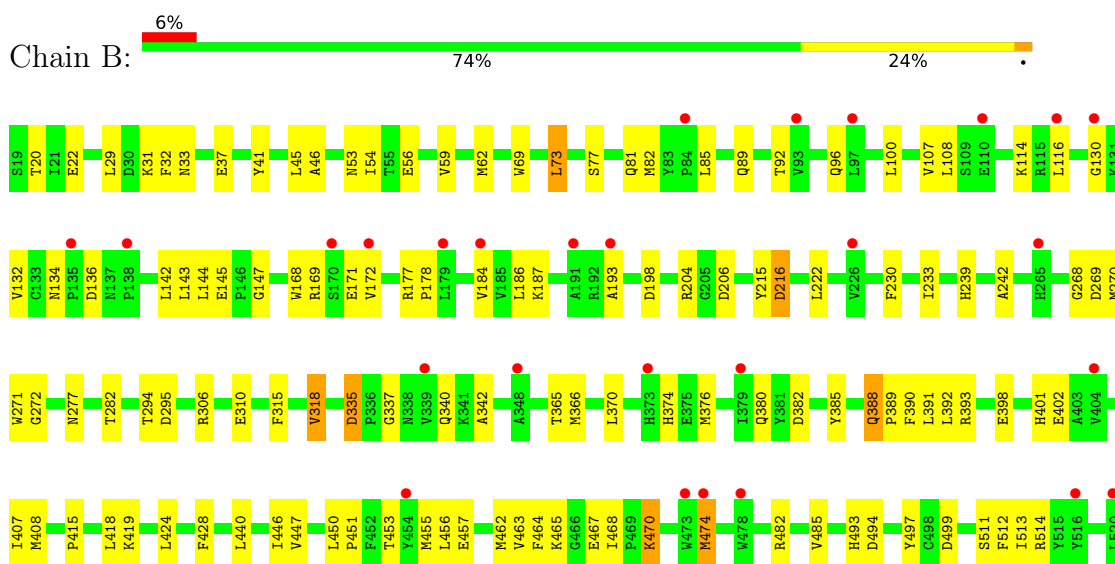



- Molecule 2: Spike protein S1

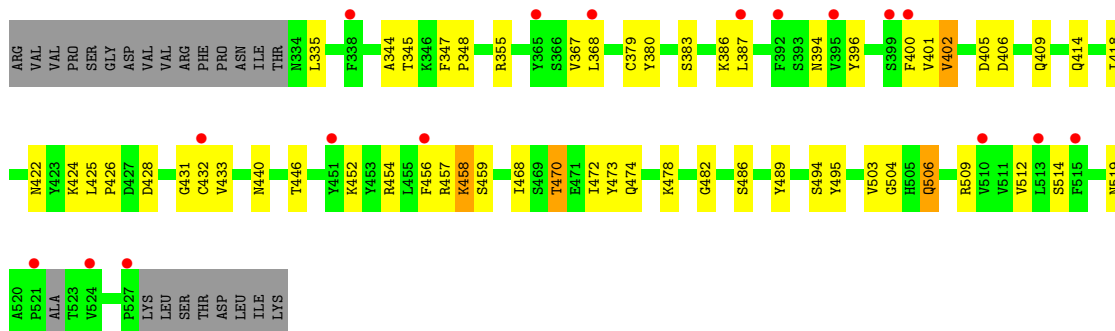

- Molecule 2: Spike protein S1

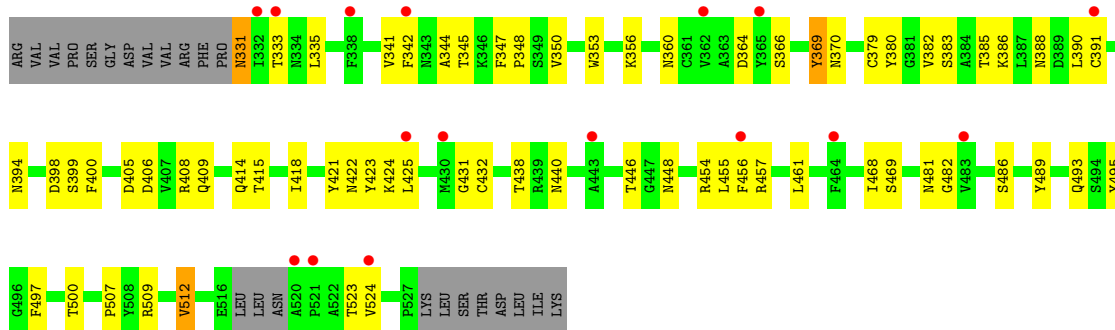

- Molecule 3: beta-D-mannopyranose-(1-4)-2-acetamido-2-deoxy-beta-D-glucopyranose-(1-4)-2-acetamido-2-deoxy-beta-D-glucopyranose



- Molecule 3: beta-D-mannopyranose-(1-4)-2-acetamido-2-deoxy-beta-D-glucopyranose-(1-4)-2-acetamido-2-deoxy-beta-D-glucopyranose



- Molecule 4: 2-acetamido-2-deoxy-beta-D-glucopyranose-(1-4)-2-acetamido-2-deoxy-beta-D-glucopyranose

Chain D:  50% 50%

NAG1
NAG2

- Molecule 4: 2-acetamido-2-deoxy-beta-D-glucopyranose-(1-4)-2-acetamido-2-deoxy-beta-D-glucopyranose

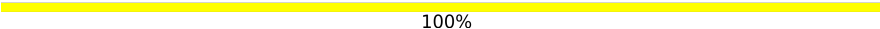
Chain G:  100%



NAG1
NAG2

- Molecule 4: 2-acetamido-2-deoxy-beta-D-glucopyranose-(1-4)-2-acetamido-2-deoxy-beta-D-glucopyranose

Chain H:  100%

NAG1
NAG2

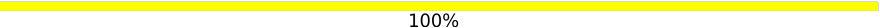
- Molecule 4: 2-acetamido-2-deoxy-beta-D-glucopyranose-(1-4)-2-acetamido-2-deoxy-beta-D-glucopyranose

Chain I:  100%

NAG1
NAG2

- Molecule 4: 2-acetamido-2-deoxy-beta-D-glucopyranose-(1-4)-2-acetamido-2-deoxy-beta-D-glucopyranose

Chain K:  50% 50%

NAG1
NAG2

- Molecule 4: 2-acetamido-2-deoxy-beta-D-glucopyranose-(1-4)-2-acetamido-2-deoxy-beta-D-glucopyranose

Chain M:  50% 50%

NAG1
NAG2

- Molecule 5: 2-acetamido-2-deoxy-beta-D-glucopyranose-(1-3)-beta-D-mannopyranose-(1-4)-2-acetamido-2-deoxy-beta-D-glucopyranose-(1-4)-2-acetamido-2-deoxy-beta-D-glucopyranose

Chain J:  50% 50%

NAG1
NAG2
BNA3
NAG4

4 Data and refinement statistics

Property	Value	Source
Space group	P 1 21 1	Depositor
Cell constants a, b, c, α , β , γ	79.74Å 116.37Å 111.66Å 90.00° 92.81° 90.00°	Depositor
Resolution (Å)	111.52 – 2.71 111.52 – 2.71	Depositor EDS
% Data completeness (in resolution range)	45.0 (111.52-2.71) 42.0 (111.52-2.71)	Depositor EDS
R_{merge}	0.15	Depositor
R_{sym}	0.15	Depositor
$\langle I/\sigma(I) \rangle$ ¹	0.59 (at 2.69Å)	Xtrriage
Refinement program	PHENIX 1.20.1_4487	Depositor
R, R_{free}	0.219 , 0.283 0.219 , 0.283	Depositor DCC
R_{free} test set	1277 reflections (2.29%)	wwPDB-VP
Wilson B-factor (Å ²)	56.5	Xtrriage
Anisotropy	0.056	Xtrriage
Bulk solvent k_{sol} (e/Å ³), B_{sol} (Å ²)	0.31 , 40.9	EDS
L-test for twinning ²	$\langle L \rangle = 0.47$, $\langle L^2 \rangle = 0.30$	Xtrriage
Estimated twinning fraction	0.044 for h,-k,-l	Xtrriage
F_o, F_c correlation	0.88	EDS
Total number of atoms	13162	wwPDB-VP
Average B, all atoms (Å ²)	71.0	wwPDB-VP

Xtrriage's analysis on translational NCS is as follows: *The largest off-origin peak in the Patterson function is 3.71% of the height of the origin peak. No significant pseudotranslation is detected.*

¹Intensities estimated from amplitudes.

²Theoretical values of $\langle |L| \rangle$, $\langle L^2 \rangle$ for acentric reflections are 0.5, 0.333 respectively for untwinned datasets, and 0.375, 0.2 for perfectly twinned datasets.

5 Model quality [i](#)

5.1 Standard geometry [i](#)

Bond lengths and bond angles in the following residue types are not validated in this section: NAG, CL, ZN, EDO, BMA

The Z score for a bond length (or angle) is the number of standard deviations the observed value is removed from the expected value. A bond length (or angle) with $|Z| > 5$ is considered an outlier worth inspection. RMSZ is the root-mean-square of all Z scores of the bond lengths (or angles).

Mol	Chain	Bond lengths		Bond angles	
		RMSZ	# Z >5	RMSZ	# Z >5
1	A	0.12	0/4999	0.30	0/6792
1	B	0.13	0/4999	0.29	0/6792
2	E	0.15	0/1564	0.35	0/2126
2	F	0.20	0/1568	0.39	0/2132
All	All	0.14	0/13130	0.32	0/17842

There are no bond length outliers.

There are no bond angle outliers.

There are no chirality outliers.

There are no planarity outliers.

5.2 Too-close contacts [i](#)

In the following table, the Non-H and H(model) columns list the number of non-hydrogen atoms and hydrogen atoms in the chain respectively. The H(added) column lists the number of hydrogen atoms added and optimized by MolProbity. The Clashes column lists the number of clashes within the asymmetric unit, whereas Symm-Clashes lists symmetry-related clashes.

Mol	Chain	Non-H	H(model)	H(added)	Clashes	Symm-Clashes
1	A	4862	0	4634	84	0
1	B	4862	0	4634	96	0
2	E	1522	0	1448	31	0
2	F	1526	0	1451	40	0
3	C	39	0	34	1	0
3	L	39	0	34	1	0
4	D	28	0	25	0	0
4	G	28	0	25	0	0
4	H	28	0	25	1	0

Continued on next page...

Continued from previous page...

Mol	Chain	Non-H	H(model)	H(added)	Clashes	Symm-Clashes
4	I	28	0	25	0	0
4	K	28	0	25	0	0
4	M	28	0	25	1	0
5	J	53	0	46	0	0
6	A	1	0	0	0	0
6	B	1	0	0	0	0
7	A	1	0	0	0	0
7	B	1	0	0	2	0
8	A	4	0	6	0	0
8	B	12	0	18	0	0
9	A	14	0	13	0	0
9	B	28	0	26	1	0
10	A	14	0	0	0	0
10	B	8	0	0	2	0
10	E	6	0	0	0	0
10	F	1	0	0	0	0
All	All	13162	0	12494	247	0

The all-atom clashscore is defined as the number of clashes found per 1000 atoms (including hydrogen atoms). The all-atom clashscore for this structure is 10.

The worst 5 of 247 close contacts within the same asymmetric unit are listed below, sorted by their clash magnitude.

Atom-1	Atom-2	Interatomic distance (Å)	Clash overlap (Å)
1:B:177:ARG:NH1	1:B:474:MET:SD	2.53	0.81
1:B:46:ALA:HB1	1:B:62:MET:HA	1.69	0.74
1:A:29:LEU:HD12	1:A:93:VAL:HG13	1.70	0.72
2:E:454:ARG:HD3	2:E:457:ARG:HB2	1.72	0.72
1:B:474:MET:SD	1:B:474:MET:N	2.64	0.71

There are no symmetry-related clashes.

5.3 Torsion angles [i](#)

5.3.1 Protein backbone [i](#)

In the following table, the Percentiles column shows the percent Ramachandran outliers of the chain as a percentile score with respect to all X-ray entries followed by that with respect to entries of similar resolution.

The Analysed column shows the number of residues for which the backbone conformation was analysed, and the total number of residues.

Mol	Chain	Analysed	Favoured	Allowed	Outliers	Percentiles	
1	A	594/597 (100%)	572 (96%)	22 (4%)	0	100	100
1	B	594/597 (100%)	573 (96%)	21 (4%)	0	100	100
2	E	189/217 (87%)	167 (88%)	21 (11%)	1 (0%)	24	46
2	F	190/217 (88%)	168 (88%)	21 (11%)	1 (0%)	24	46
All	All	1567/1628 (96%)	1480 (94%)	85 (5%)	2 (0%)	48	72

All (2) Ramachandran outliers are listed below:

Mol	Chain	Res	Type
2	F	364	ASP
2	E	459	SER

5.3.2 Protein sidechains [i](#)

In the following table, the Percentiles column shows the percent sidechain outliers of the chain as a percentile score with respect to all X-ray entries followed by that with respect to entries of similar resolution.

The Analysed column shows the number of residues for which the sidechain conformation was analysed, and the total number of residues.

Mol	Chain	Analysed	Rotameric	Outliers	Percentiles	
1	A	526/527 (100%)	499 (95%)	27 (5%)	21	46
1	B	526/527 (100%)	499 (95%)	27 (5%)	21	46
2	E	166/189 (88%)	154 (93%)	12 (7%)	13	31
2	F	166/189 (88%)	155 (93%)	11 (7%)	15	35
All	All	1384/1432 (97%)	1307 (94%)	77 (6%)	19	42

5 of 77 residues with a non-rotameric sidechain are listed below:

Mol	Chain	Res	Type
2	E	394	ASN
2	F	415	THR
2	E	446	THR
2	E	519	ASN
2	F	486	SER

Sometimes sidechains can be flipped to improve hydrogen bonding and reduce clashes. 5 of 13 such sidechains are listed below:

Mol	Chain	Res	Type
1	B	221	GLN
2	E	334	ASN
2	F	474	GLN
2	E	477	ASN
2	E	481	ASN

5.3.3 RNA [i](#)

There are no RNA molecules in this entry.

5.4 Non-standard residues in protein, DNA, RNA chains [i](#)

There are no non-standard protein/DNA/RNA residues in this entry.

5.5 Carbohydrates [i](#)

22 monosaccharides are modelled in this entry.

In the following table, the Counts columns list the number of bonds (or angles) for which Mogul statistics could be retrieved, the number of bonds (or angles) that are observed in the model and the number of bonds (or angles) that are defined in the Chemical Component Dictionary. The Link column lists molecule types, if any, to which the group is linked. The Z score for a bond length (or angle) is the number of standard deviations the observed value is removed from the expected value. A bond length (or angle) with $|Z| > 2$ is considered an outlier worth inspection. RMSZ is the root-mean-square of all Z scores of the bond lengths (or angles).

Mol	Type	Chain	Res	Link	Bond lengths			Bond angles		
					Counts	RMSZ	$\# Z > 2$	Counts	RMSZ	$\# Z > 2$
3	NAG	C	1	3,1	14,14,15	0.36	0	17,19,21	0.51	0
3	NAG	C	2	3	14,14,15	0.21	0	17,19,21	0.46	0
3	BMA	C	3	3	11,11,12	0.68	0	15,15,17	0.70	0
4	NAG	D	1	4,1	14,14,15	0.17	0	17,19,21	0.60	0
4	NAG	D	2	4	14,14,15	1.87	1 (7%)	17,19,21	2.65	1 (5%)
4	NAG	G	1	4,1	14,14,15	0.32	0	17,19,21	0.80	1 (5%)
4	NAG	G	2	4	14,14,15	0.94	1 (7%)	17,19,21	1.61	2 (11%)
4	NAG	H	1	4,1	14,14,15	0.24	0	17,19,21	0.69	1 (5%)
4	NAG	H	2	4	14,14,15	1.81	2 (14%)	17,19,21	2.73	1 (5%)
4	NAG	I	1	4,1	14,14,15	0.39	0	17,19,21	0.83	1 (5%)

Mol	Type	Chain	Res	Link	Bond lengths			Bond angles		
					Counts	RMSZ	# Z > 2	Counts	RMSZ	# Z > 2
4	NAG	I	2	4	14,14,15	2.03	1 (7%)	17,19,21	2.60	1 (5%)
5	NAG	J	1	5,1	14,14,15	0.33	0	17,19,21	0.43	0
5	NAG	J	2	5	14,14,15	0.23	0	17,19,21	0.41	0
5	BMA	J	3	5	11,11,12	0.77	0	15,15,17	1.00	1 (6%)
5	NAG	J	4	5	14,14,15	0.98	2 (14%)	17,19,21	0.89	1 (5%)
4	NAG	K	1	4,1	14,14,15	0.24	0	17,19,21	0.44	0
4	NAG	K	2	4	14,14,15	1.83	1 (7%)	17,19,21	2.69	1 (5%)
3	NAG	L	1	3,2	14,14,15	0.43	0	17,19,21	0.62	0
3	NAG	L	2	3	14,14,15	0.17	0	17,19,21	0.48	0
3	BMA	L	3	3	11,11,12	1.34	1 (9%)	15,15,17	1.00	1 (6%)
4	NAG	M	1	4,2	14,14,15	0.26	0	17,19,21	0.65	0
4	NAG	M	2	4	14,14,15	1.38	2 (14%)	17,19,21	1.89	2 (11%)

In the following table, the Chirals column lists the number of chiral outliers, the number of chiral centers analysed, the number of these observed in the model and the number defined in the Chemical Component Dictionary. Similar counts are reported in the Torsion and Rings columns. '-' means no outliers of that kind were identified.

Mol	Type	Chain	Res	Link	Chirals	Torsions	Rings
3	NAG	C	1	3,1	-	2/6/23/26	0/1/1/1
3	NAG	C	2	3	-	1/6/23/26	0/1/1/1
3	BMA	C	3	3	-	1/2/19/22	0/1/1/1
4	NAG	D	1	4,1	-	3/6/23/26	0/1/1/1
4	NAG	D	2	4	-	2/6/23/26	0/1/1/1
4	NAG	G	1	4,1	-	2/6/23/26	0/1/1/1
4	NAG	G	2	4	-	3/6/23/26	0/1/1/1
4	NAG	H	1	4,1	-	2/6/23/26	0/1/1/1
4	NAG	H	2	4	-	0/6/23/26	0/1/1/1
4	NAG	I	1	4,1	-	2/6/23/26	0/1/1/1
4	NAG	I	2	4	-	2/6/23/26	0/1/1/1
5	NAG	J	1	5,1	-	0/6/23/26	0/1/1/1
5	NAG	J	2	5	-	2/6/23/26	0/1/1/1
5	BMA	J	3	5	-	0/2/19/22	0/1/1/1
5	NAG	J	4	5	-	4/6/23/26	0/1/1/1
4	NAG	K	1	4,1	-	2/6/23/26	0/1/1/1
4	NAG	K	2	4	-	2/6/23/26	0/1/1/1
3	NAG	L	1	3,2	-	2/6/23/26	0/1/1/1
3	NAG	L	2	3	-	3/6/23/26	0/1/1/1

Continued on next page...

Continued from previous page...

Mol	Type	Chain	Res	Link	Chirals	Torsions	Rings
3	BMA	L	3	3	-	1/2/19/22	0/1/1/1
4	NAG	M	1	4,2	-	0/6/23/26	0/1/1/1
4	NAG	M	2	4	-	6/6/23/26	0/1/1/1

The worst 5 of 11 bond length outliers are listed below:

Mol	Chain	Res	Type	Atoms	Z	Observed(Å)	Ideal(Å)
4	I	2	NAG	O5-C1	7.26	1.55	1.43
4	D	2	NAG	O5-C1	6.67	1.54	1.43
4	K	2	NAG	O5-C1	6.55	1.54	1.43
4	H	2	NAG	O5-C1	6.23	1.54	1.43
4	M	2	NAG	O5-C1	4.06	1.50	1.43

The worst 5 of 14 bond angle outliers are listed below:

Mol	Chain	Res	Type	Atoms	Z	Observed(°)	Ideal(°)
4	H	2	NAG	C1-O5-C5	11.07	127.03	112.19
4	K	2	NAG	C1-O5-C5	10.92	126.82	112.19
4	D	2	NAG	C1-O5-C5	10.72	126.55	112.19
4	I	2	NAG	C1-O5-C5	10.54	126.31	112.19
4	G	2	NAG	C1-O5-C5	5.98	120.20	112.19

There are no chirality outliers.

5 of 42 torsion outliers are listed below:

Mol	Chain	Res	Type	Atoms
5	J	2	NAG	O5-C5-C6-O6
4	I	1	NAG	O5-C5-C6-O6
4	M	2	NAG	O5-C5-C6-O6
3	C	1	NAG	O5-C5-C6-O6
4	K	1	NAG	O5-C5-C6-O6

There are no ring outliers.

6 monomers are involved in 4 short contacts:

Mol	Chain	Res	Type	Clashes	Symm-Clashes
3	L	2	NAG	1	0
3	L	3	BMA	1	0
4	H	2	NAG	1	0
4	H	1	NAG	1	0
3	C	1	NAG	1	0

Continued on next page...

Continued from previous page...

Mol	Chain	Res	Type	Clashes	Symm-Clashes
4	M	2	NAG	1	0

The following is a two-dimensional graphical depiction of Mogul quality analysis of bond lengths, bond angles, torsion angles, and ring geometry for oligosaccharide.

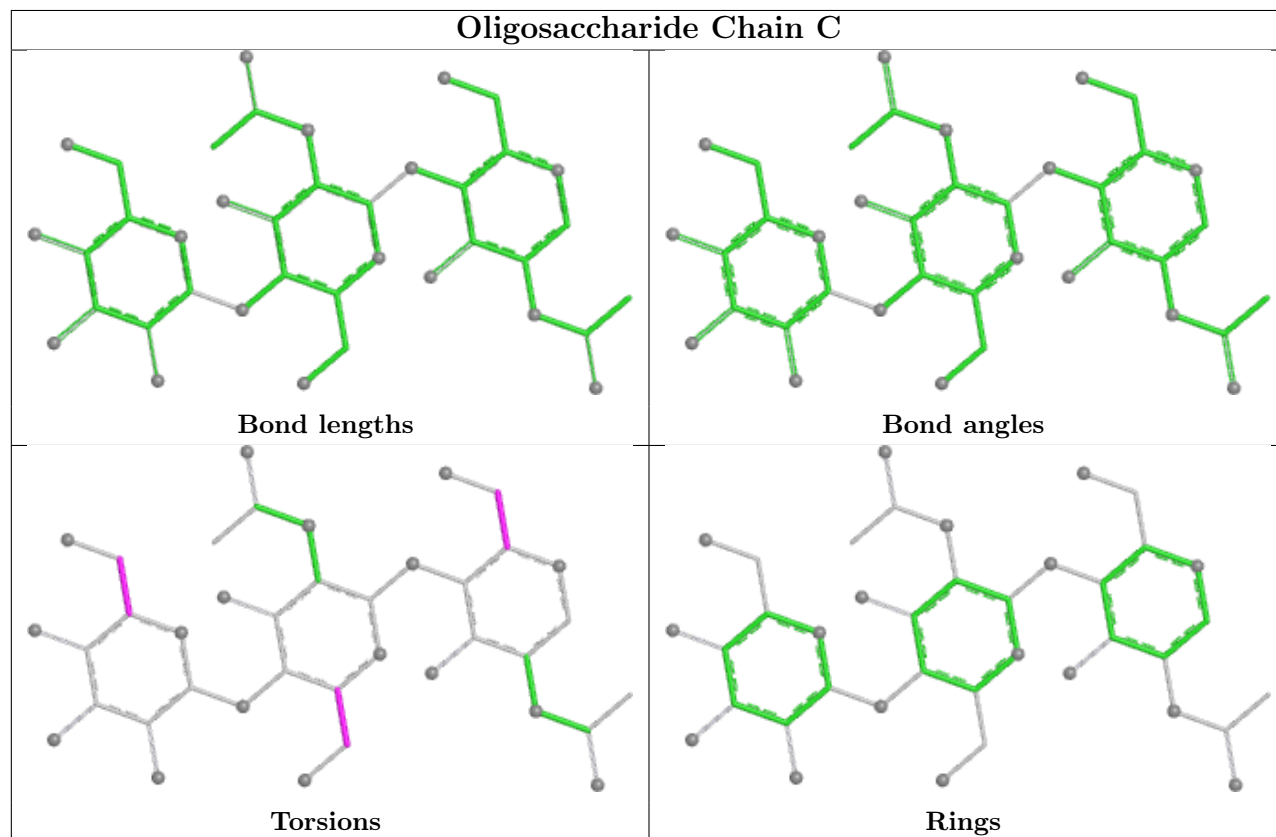

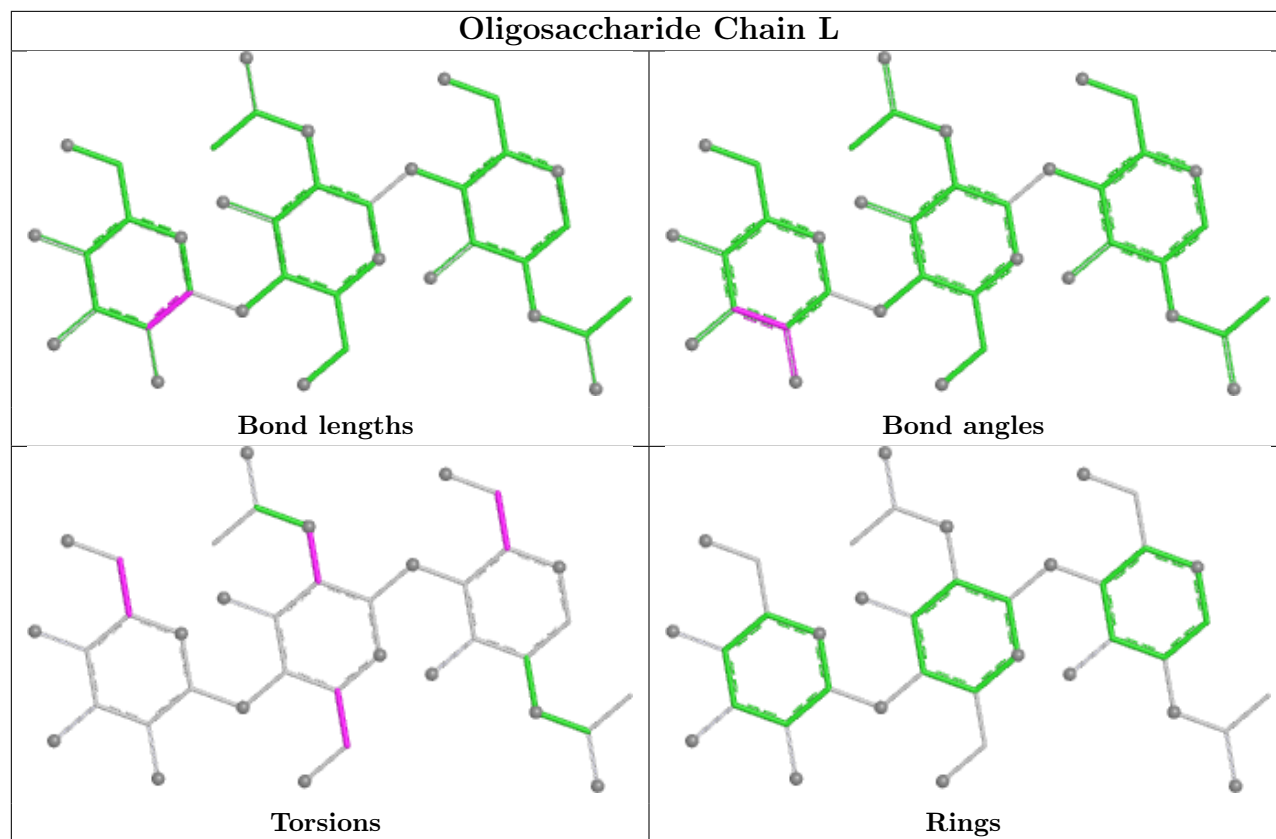

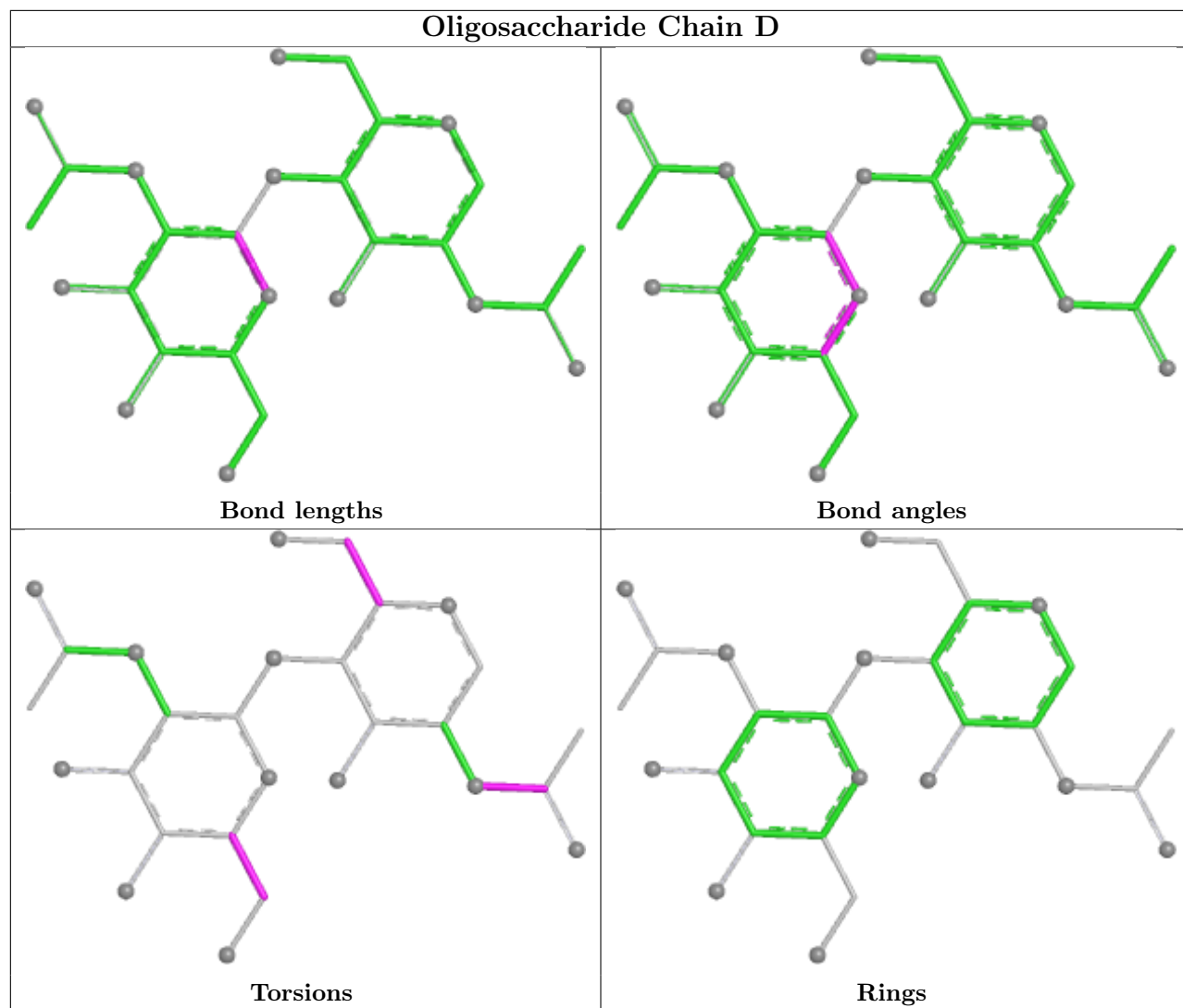

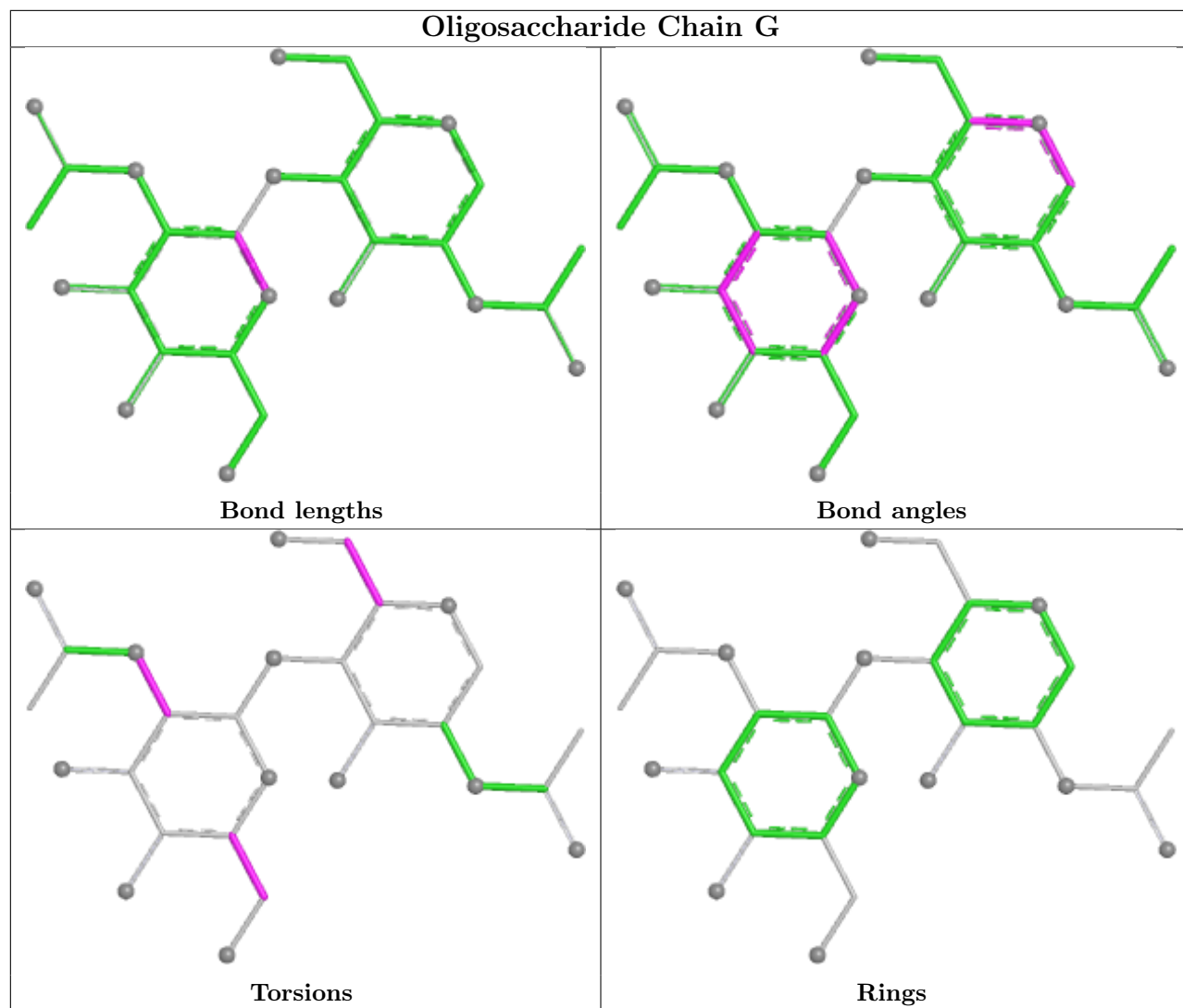

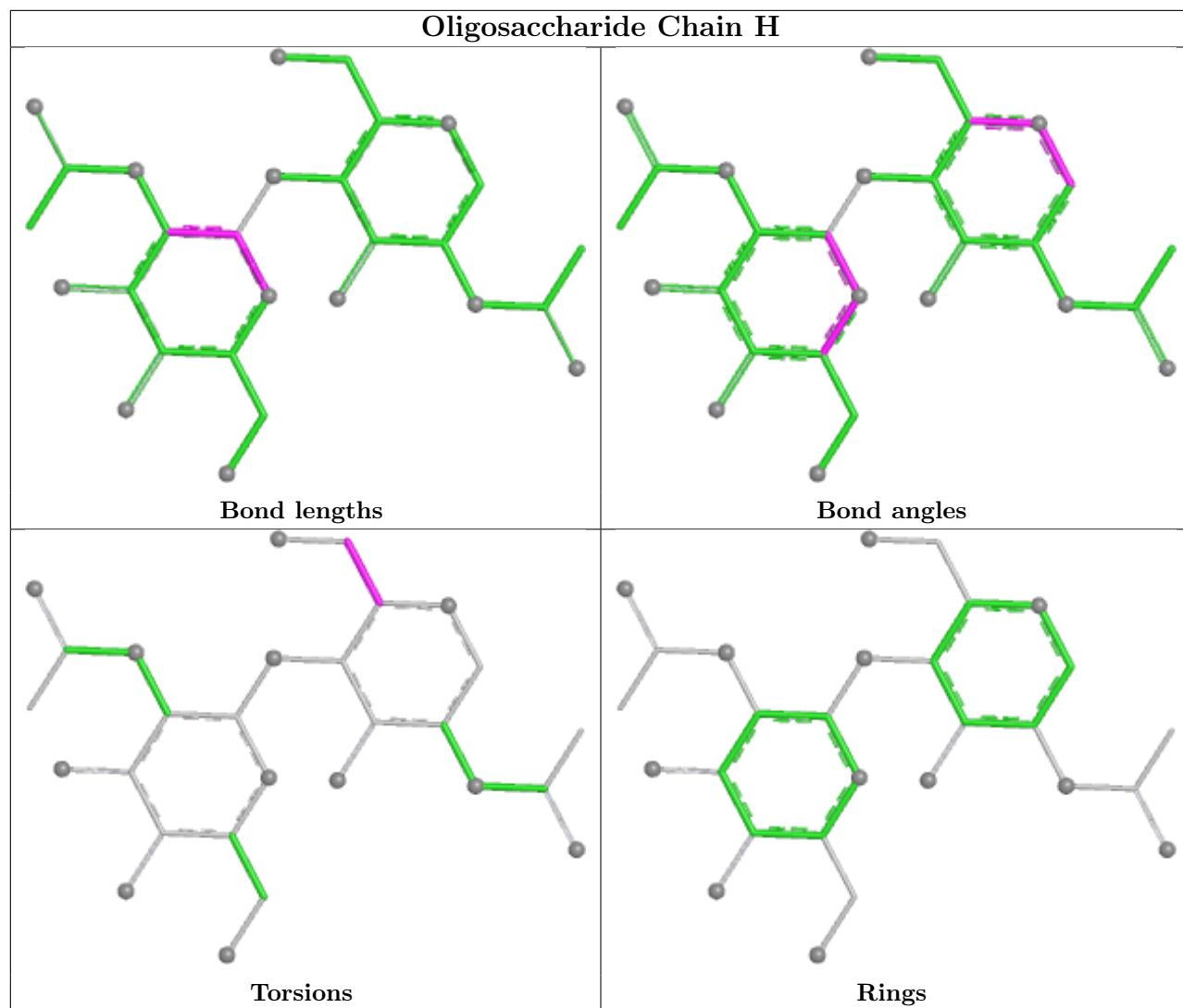

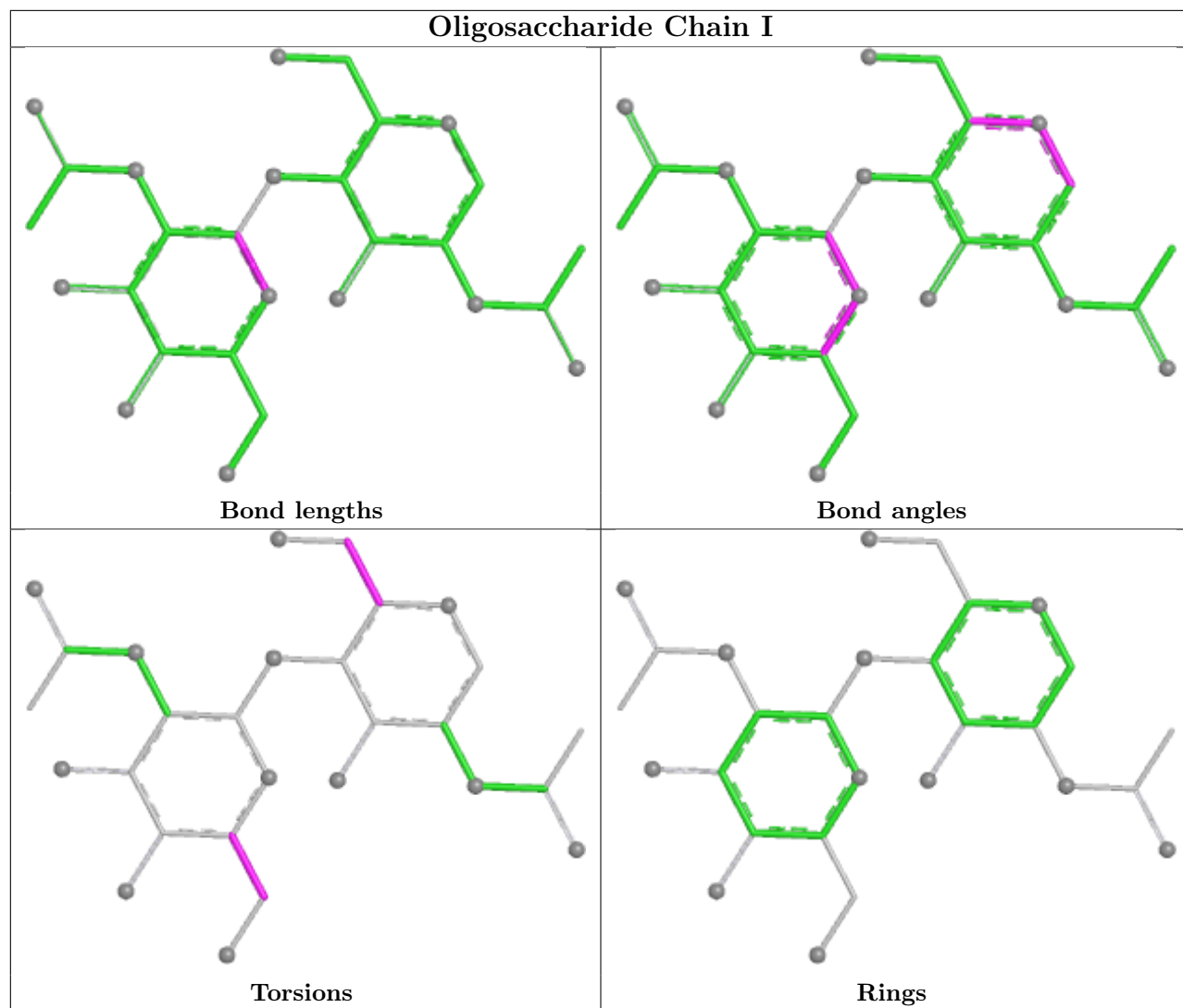

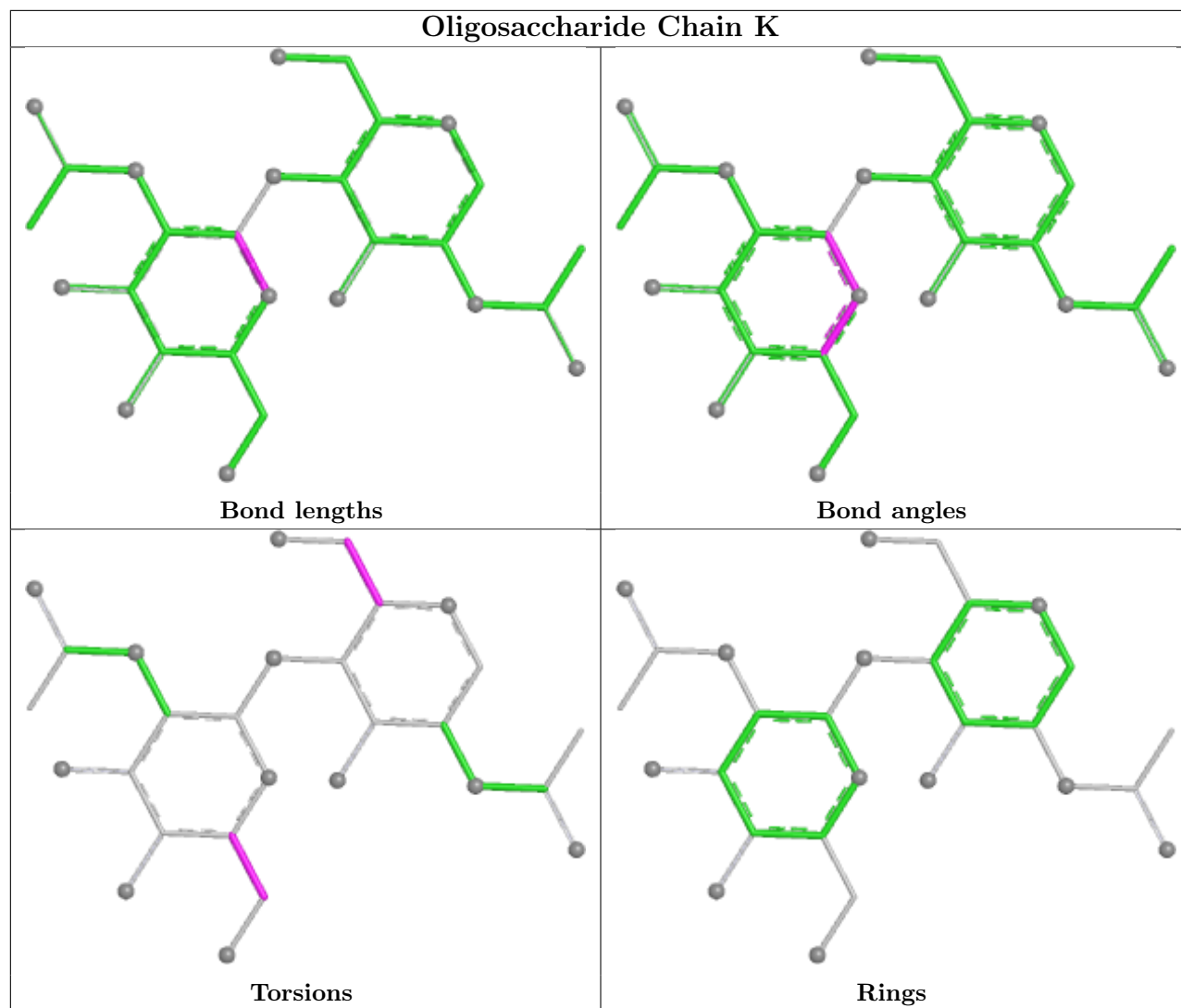

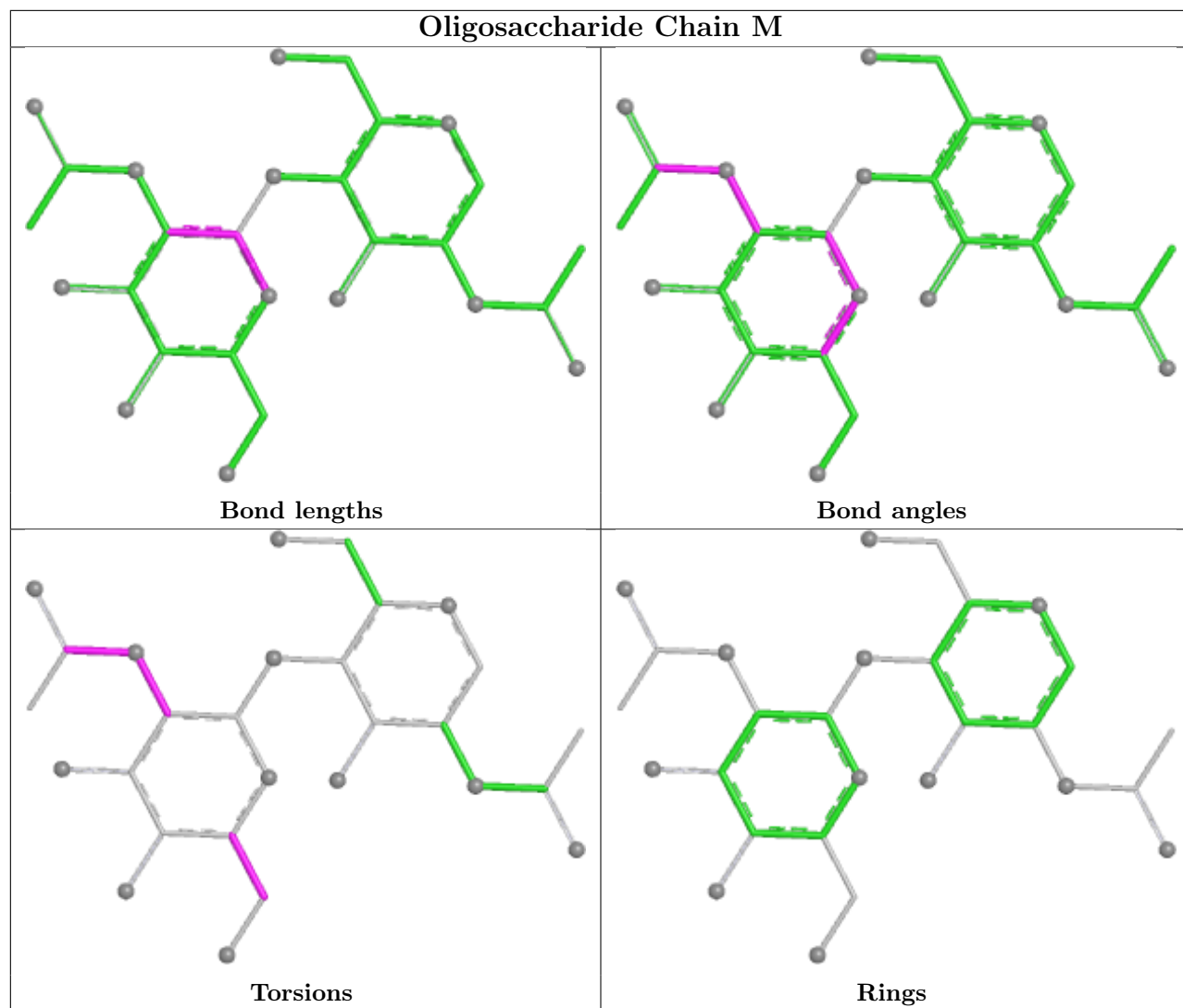

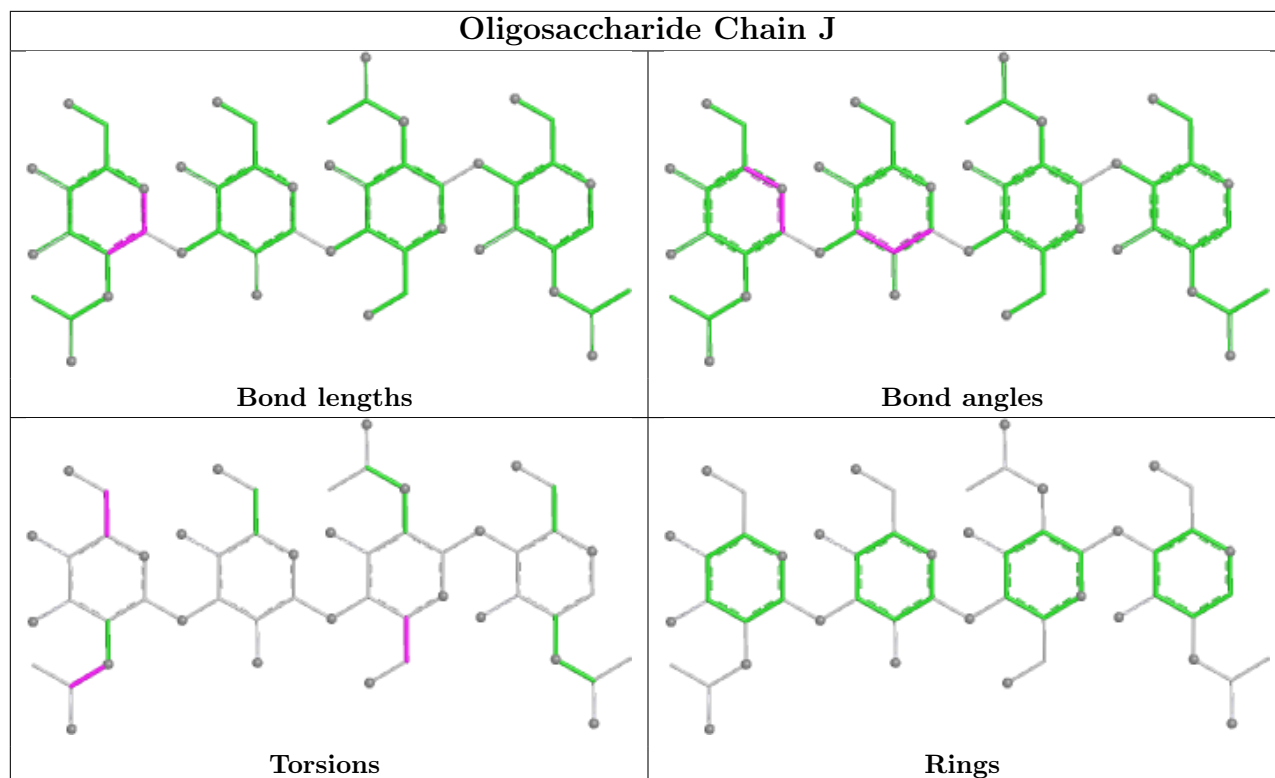

5.6 Ligand geometry [i](#)

Of 11 ligands modelled in this entry, 4 are monoatomic - leaving 7 for Mogul analysis.

In the following table, the Counts columns list the number of bonds (or angles) for which Mogul statistics could be retrieved, the number of bonds (or angles) that are observed in the model and the number of bonds (or angles) that are defined in the Chemical Component Dictionary. The Link column lists molecule types, if any, to which the group is linked. The Z score for a bond length (or angle) is the number of standard deviations the observed value is removed from the expected value. A bond length (or angle) with $|Z| > 2$ is considered an outlier worth inspection. RMSZ is the root-mean-square of all Z scores of the bond lengths (or angles).

Mol	Type	Chain	Res	Link	Bond lengths			Bond angles		
					Counts	RMSZ	$\# Z > 2$	Counts	RMSZ	$\# Z > 2$
9	NAG	B	707	1	14,14,15	0.30	0	17,19,21	0.43	0
8	EDO	B	705	-	3,3,3	0.42	0	2,2,2	0.39	0
8	EDO	B	704	-	3,3,3	0.43	0	2,2,2	0.38	0
8	EDO	A	703	-	3,3,3	0.43	0	2,2,2	0.38	0
9	NAG	A	704	1	14,14,15	0.39	0	17,19,21	0.56	0
9	NAG	B	706	1	14,14,15	0.27	0	17,19,21	0.48	0
8	EDO	B	703	-	3,3,3	0.42	0	2,2,2	0.39	0

In the following table, the Chirals column lists the number of chiral outliers, the number of chiral centers analysed, the number of these observed in the model and the number defined in the Chemical Component Dictionary. Similar counts are reported in the Torsion and Rings columns.

'-' means no outliers of that kind were identified.

Mol	Type	Chain	Res	Link	Chirals	Torsions	Rings
9	NAG	B	707	1	-	0/6/23/26	0/1/1/1
8	EDO	B	705	-	-	0/1/1/1	-
8	EDO	B	704	-	-	0/1/1/1	-
8	EDO	A	703	-	-	0/1/1/1	-
9	NAG	A	704	1	-	0/6/23/26	0/1/1/1
9	NAG	B	706	1	-	2/6/23/26	0/1/1/1
8	EDO	B	703	-	-	0/1/1/1	-

There are no bond length outliers.

There are no bond angle outliers.

There are no chirality outliers.

All (2) torsion outliers are listed below:

Mol	Chain	Res	Type	Atoms
9	B	706	NAG	O5-C5-C6-O6
9	B	706	NAG	C4-C5-C6-O6

There are no ring outliers.

1 monomer is involved in 1 short contact:

Mol	Chain	Res	Type	Clashes	Symm-Clashes
9	B	707	NAG	1	0

5.7 Other polymers [i](#)

There are no such residues in this entry.

5.8 Polymer linkage issues [i](#)

There are no chain breaks in this entry.

6 Fit of model and data [i](#)

6.1 Protein, DNA and RNA chains [i](#)

In the following table, the column labelled ‘#RSRZ > 2’ contains the number (and percentage) of RSRZ outliers, followed by percent RSRZ outliers for the chain as percentile scores relative to all X-ray entries and entries of similar resolution. The OWAB column contains the minimum, median, 95th percentile and maximum values of the occupancy-weighted average B-factor per residue. The column labelled ‘Q < 0.9’ lists the number of (and percentage) of residues with an average occupancy less than 0.9.

Mol	Chain	Analysed	<RSRZ>	#RSRZ>2	OWAB(Å ²)	Q<0.9
1	A	596/597 (99%)	0.54	27 (4%) 38 35	37, 67, 116, 181	0
1	B	596/597 (99%)	0.56	33 (5%) 30 27	35, 60, 106, 194	0
2	E	193/217 (88%)	0.76	17 (8%) 15 14	45, 70, 126, 153	0
2	F	194/217 (89%)	0.77	16 (8%) 17 15	50, 76, 135, 196	0
All	All	1579/1628 (96%)	0.60	93 (5%) 28 25	35, 66, 120, 196	0

The worst 5 of 93 RSRZ outliers are listed below:

Mol	Chain	Res	Type	RSRZ
1	A	525	PHE	4.1
1	A	554	LEU	3.8
1	B	97	LEU	3.8
2	F	342	PHE	3.7
2	E	387	LEU	3.6

6.2 Non-standard residues in protein, DNA, RNA chains [i](#)

There are no non-standard protein/DNA/RNA residues in this entry.

6.3 Carbohydrates [i](#)

In the following table, the Atoms column lists the number of modelled atoms in the group and the number defined in the chemical component dictionary. The B-factors column lists the minimum, median, 95th percentile and maximum values of B factors of atoms in the group. The column labelled ‘Q < 0.9’ lists the number of atoms with occupancy less than 0.9.

Mol	Type	Chain	Res	Atoms	RSCC	RSR	B-factors(Å ²)	Q<0.9
3	NAG	C	1	14/15	-	-	66,78,85,87	0
3	NAG	C	2	14/15	-	-	57,79,96,98	0

Continued on next page...

Continued from previous page...

Mol	Type	Chain	Res	Atoms	RSCC	RSR	B-factors(\AA^2)	Q<0.9
3	BMA	C	3	11/12	-	-	68,83,93,93	0
4	NAG	K	2	14/15	0.51	0.13	98,112,122,127	0
3	NAG	L	2	14/15	0.54	0.13	81,108,125,128	0
4	NAG	M	2	14/15	0.59	0.11	78,101,108,111	0
4	NAG	D	1	14/15	-	-	86,95,106,113	0
4	NAG	D	2	14/15	-	-	86,102,108,108	0
4	NAG	G	2	14/15	0.67	0.12	75,95,109,115	0
3	NAG	L	1	14/15	0.71	0.12	82,101,113,113	0
4	NAG	M	1	14/15	0.72	0.13	90,105,111,117	0
5	BMA	J	3	11/12	0.72	0.11	71,77,88,90	0
5	NAG	J	4	14/15	0.72	0.12	60,83,92,96	0
4	NAG	I	1	14/15	0.73	0.12	68,83,92,94	0
4	NAG	H	2	14/15	0.73	0.13	112,124,131,135	0
3	BMA	L	3	11/12	0.75	0.10	75,94,107,109	0
4	NAG	K	1	14/15	0.78	0.11	79,91,98,106	0
4	NAG	G	1	14/15	0.78	0.09	65,85,92,102	0
4	NAG	H	1	14/15	0.78	0.10	70,102,113,118	0
4	NAG	I	2	14/15	0.82	0.09	68,90,96,97	0
5	NAG	J	2	14/15	0.89	0.08	46,63,75,81	0
5	NAG	J	1	14/15	0.93	0.07	44,55,61,62	0

The following is a graphical depiction of the model fit to experimental electron density for oligosaccharide. Each fit is shown from different orientation to approximate a three-dimensional view.

Electron density around Chain C:

$2mF_o-DF_c$ (at 0.7 rmsd) in gray
 mF_o-DF_c (at 3 rmsd) in purple (negative)
and green (positive)

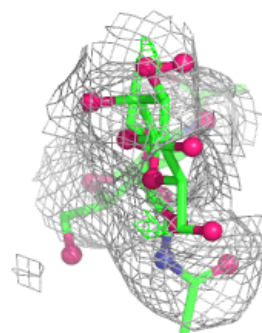
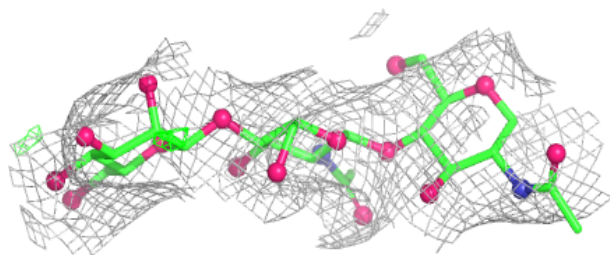
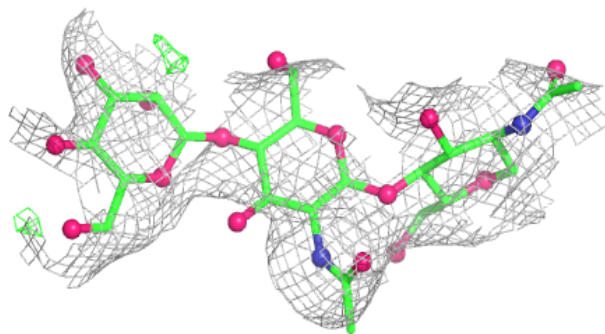
**Electron density around Chain L:**

$2mF_o-DF_c$ (at 0.7 rmsd) in gray
 mF_o-DF_c (at 3 rmsd) in purple (negative)
and green (positive)

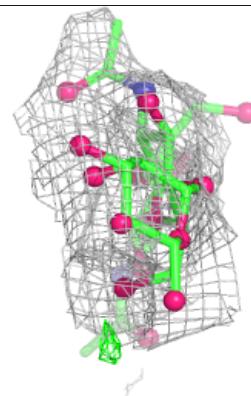
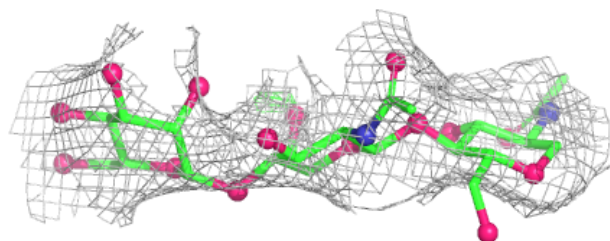
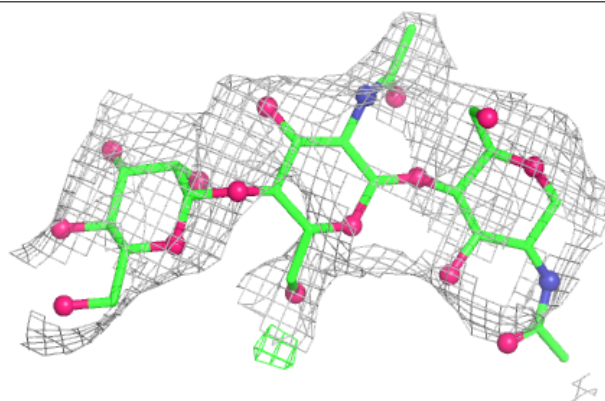

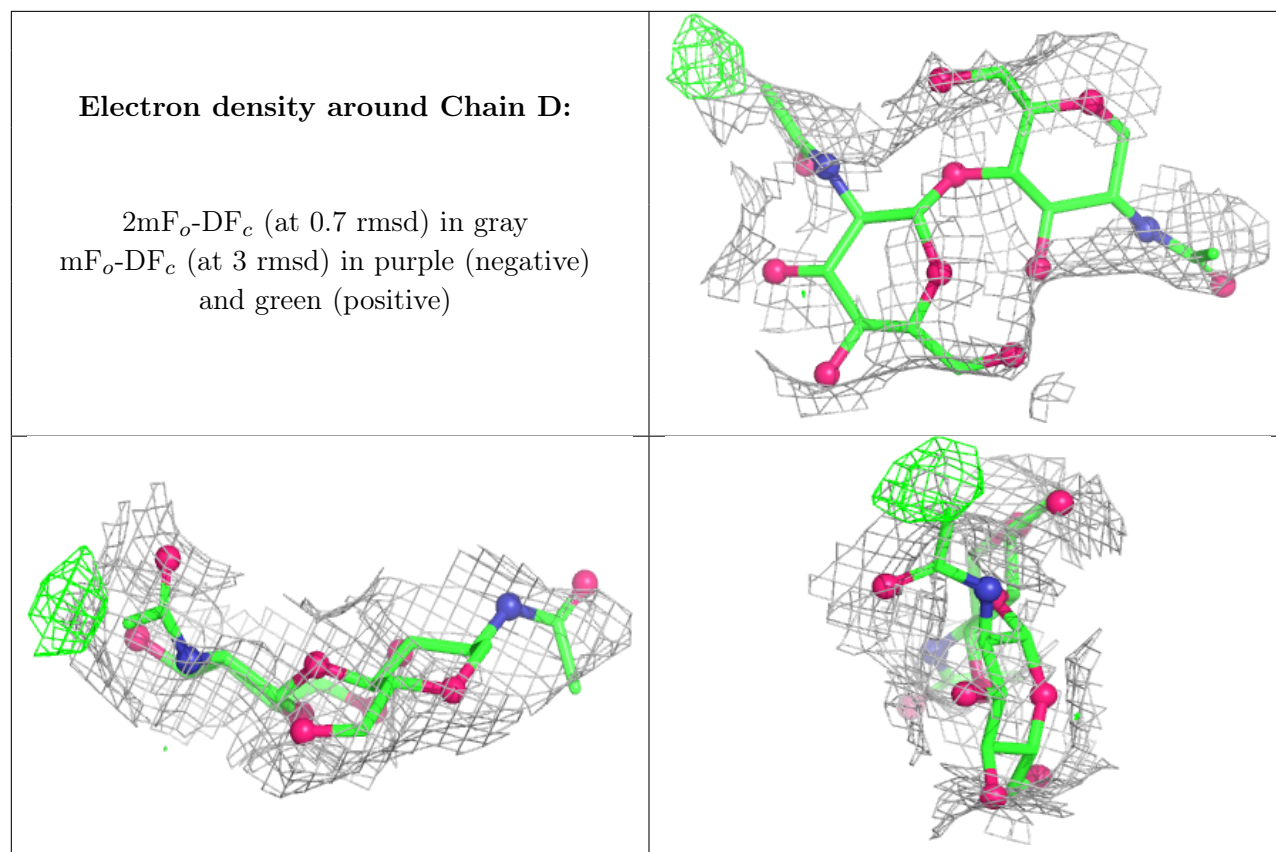

Electron density around Chain G:

$2mF_o-DF_c$ (at 0.7 rmsd) in gray
 mF_o-DF_c (at 3 rmsd) in purple (negative)
and green (positive)

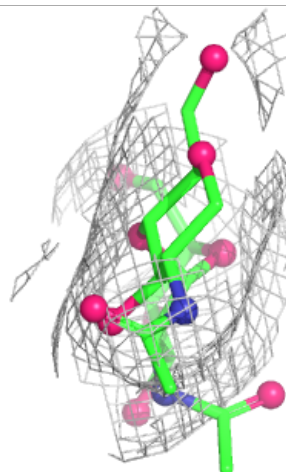
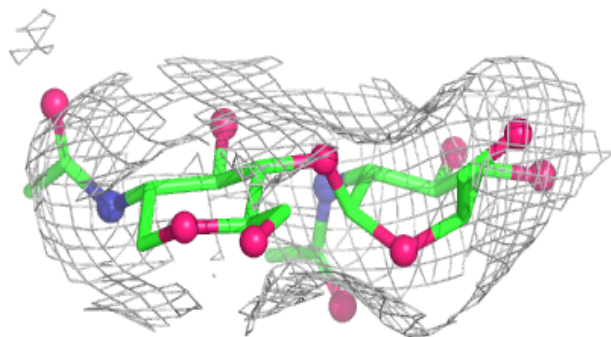
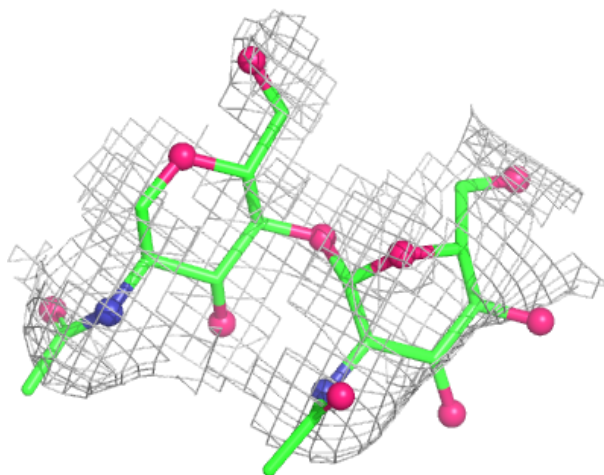

Electron density around Chain H:

$2mF_o-DF_c$ (at 0.7 rmsd) in gray
 mF_o-DF_c (at 3 rmsd) in purple (negative)
and green (positive)

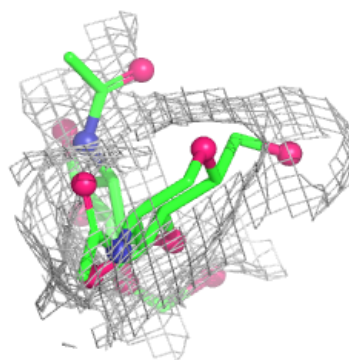
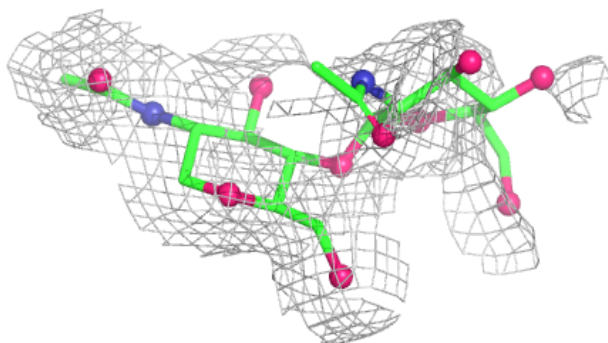
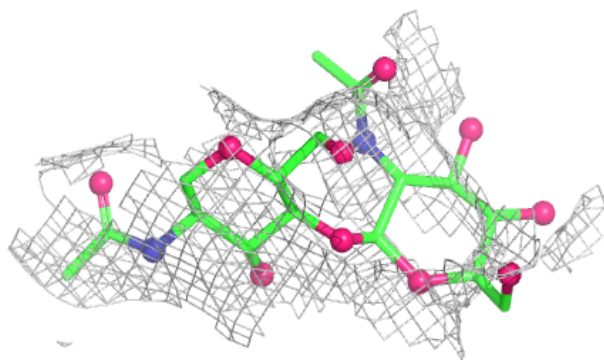
**Electron density around Chain I:**

$2mF_o-DF_c$ (at 0.7 rmsd) in gray
 mF_o-DF_c (at 3 rmsd) in purple (negative)
and green (positive)

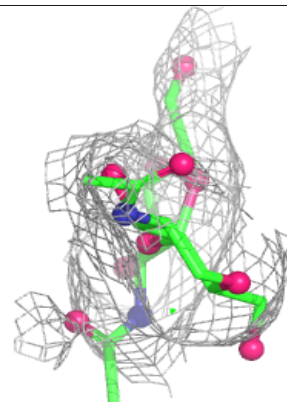
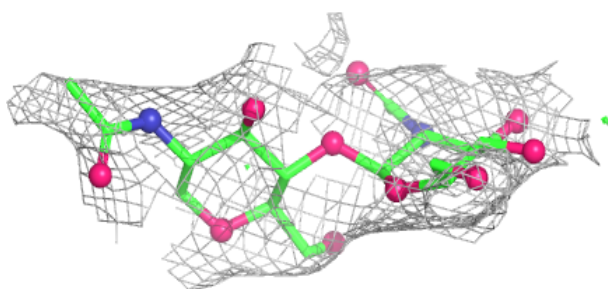
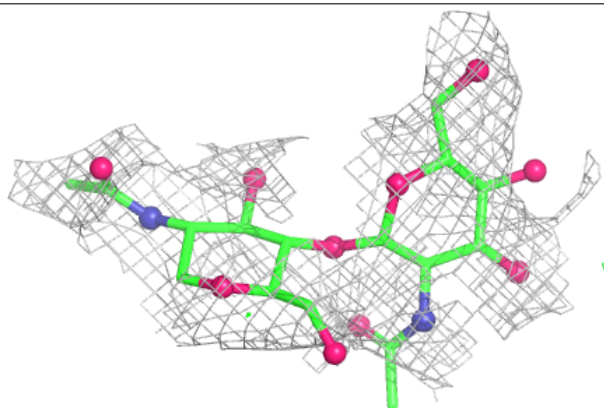

Electron density around Chain K:

$2mF_o-DF_c$ (at 0.7 rmsd) in gray
 mF_o-DF_c (at 3 rmsd) in purple (negative)
and green (positive)

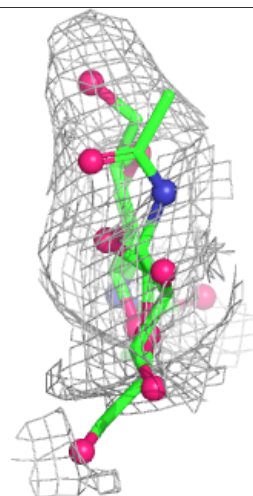
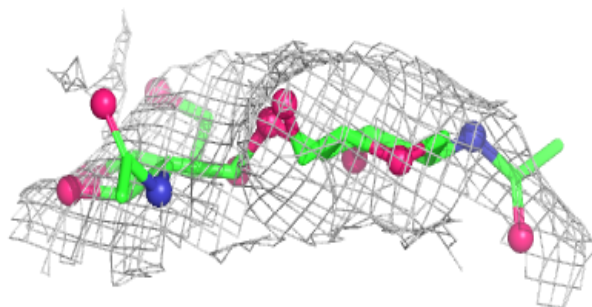
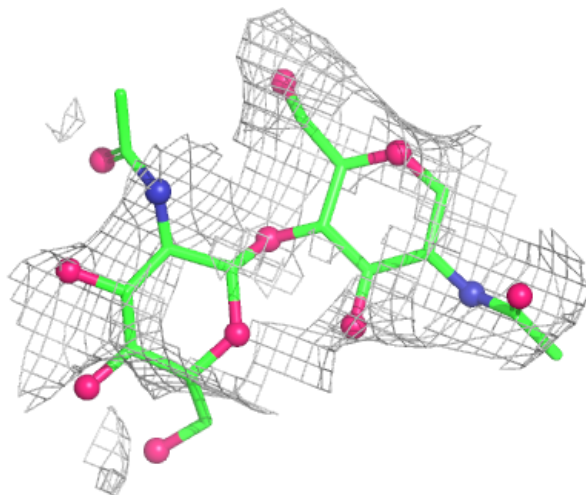

Electron density around Chain M:

$2mF_o-DF_c$ (at 0.7 rmsd) in gray
 mF_o-DF_c (at 3 rmsd) in purple (negative)
and green (positive)

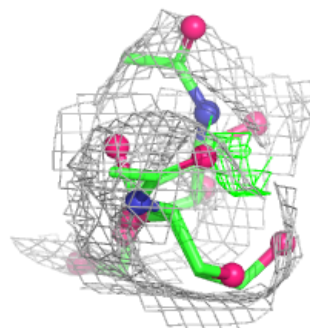
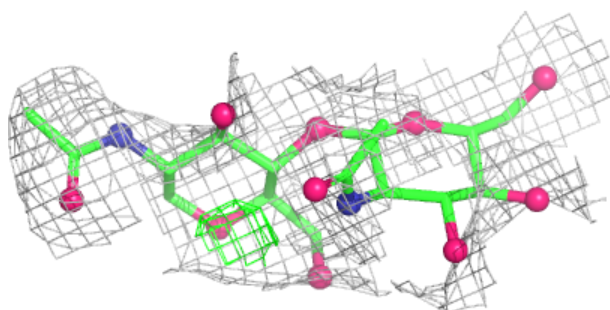
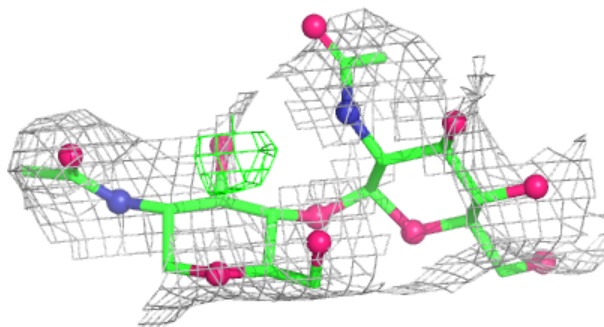
**Electron density around Chain J:**

$2mF_o-DF_c$ (at 0.7 rmsd) in gray
 mF_o-DF_c (at 3 rmsd) in purple (negative)
and green (positive)

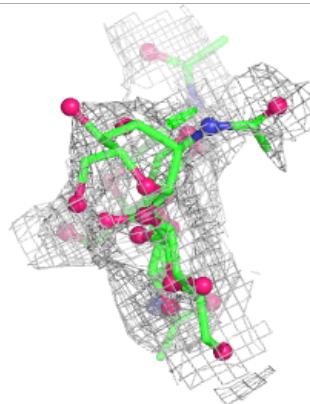
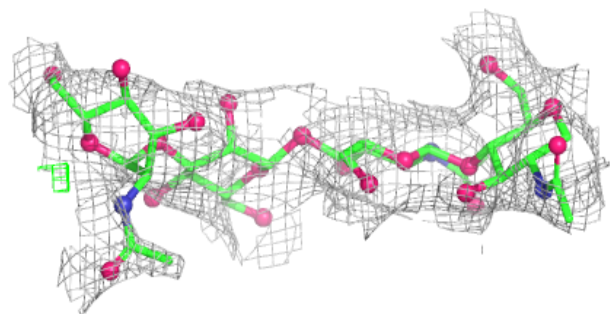
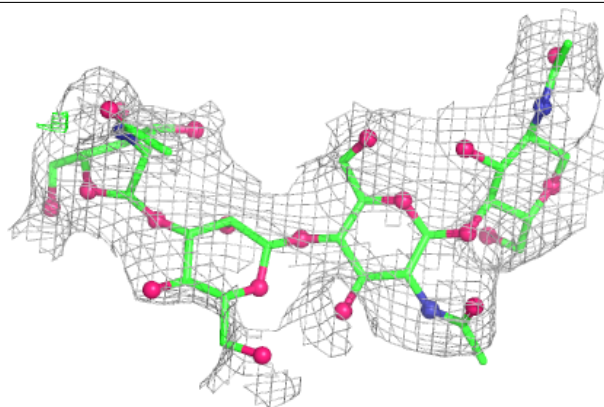

6.4 Ligands [i](#)

In the following table, the Atoms column lists the number of modelled atoms in the group and the number defined in the chemical component dictionary. The B-factors column lists the minimum, median, 95th percentile and maximum values of B factors of atoms in the group. The column labelled 'Q<0.9' lists the number of atoms with occupancy less than 0.9.

Mol	Type	Chain	Res	Atoms	RSCC	RSR	B-factors(Å ²)	Q<0.9
9	NAG	A	704	14/15	0.71	0.12	72,80,88,91	0
7	CL	A	702	1/1	0.78	0.35	99,99,99,99	0
9	NAG	B	706	14/15	0.84	0.12	62,82,95,102	0
9	NAG	B	707	14/15	0.86	0.09	63,79,90,96	0
7	CL	B	702	1/1	0.87	0.08	60,60,60,60	0
8	EDO	A	703	4/4	0.88	0.08	53,56,57,62	0
6	ZN	A	701	1/1	0.88	0.08	87,87,87,87	0
8	EDO	B	704	4/4	0.89	0.10	26,35,43,46	0
8	EDO	B	703	4/4	0.92	0.11	44,56,56,66	0
8	EDO	B	705	4/4	0.94	0.09	31,32,33,47	0
6	ZN	B	701	1/1	0.95	0.07	75,75,75,75	0

6.5 Other polymers [i](#)

There are no such residues in this entry.