



wwPDB EM Validation Summary Report ⓘ

Mar 9, 2026 – 06:56 PM UTC

PDB ID : 8WAR / pdb_00008war
EMDB ID : EMD-37402
Title : Structure of transcribing complex 8 (TC8), the initially transcribing complex with Pol II positioned 8nt downstream of TSS.
Authors : Chen, X.; Liu, W.; Wang, Q.; Wang, X.; Ren, Y.; Qu, X.; Li, W.; Xu, Y.
Deposited on : 2023-09-08
Resolution : 7.20 Å(reported)

This is a wwPDB EM Validation Summary Report for a publicly released PDB entry.

We welcome your comments at validation@mail.wwpdb.org

A user guide is available at

<https://www.wwpdb.org/validation/2017/EMValidationReportHelp>

with specific help available everywhere you see the ⓘ symbol.

The types of validation reports are described at

<http://www.wwpdb.org/validation/2017/FAQs#types>.

The following versions of software and data (see [references ⓘ](#)) were used in the production of this report:

EMDB validation analysis : 0.0.1.dev132
Mogul : 2022.3.0, CSD as543be (2022)
MolProbity : 4-5-2 with Phenix2.0
Buster-report : wwPDB partial adaption of 1.1.7 (2018)
Percentile statistics : 20250101.v01 (using entries in the PDB archive January 1st 2025)
EM percentile statistics : 202505.v01 (Using data in the EMDB archive up until May 2025)
MapQ : 1.9.13
Ideal geometry (proteins) : Engh & Huber (2001)
Ideal geometry (DNA, RNA) : Parkinson et al. (1996)
Validation Pipeline (wwPDB-VP) : 2.49

1 Overall quality at a glance i

The following experimental techniques were used to determine the structure:
ELECTRON MICROSCOPY

The reported resolution of this entry is 7.20 Å.

Percentile scores (ranging between 0-100) for global validation metrics of the entry are shown in the following graphic. The table shows the number of entries on which the scores are based.

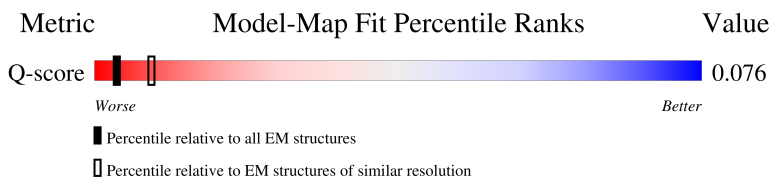
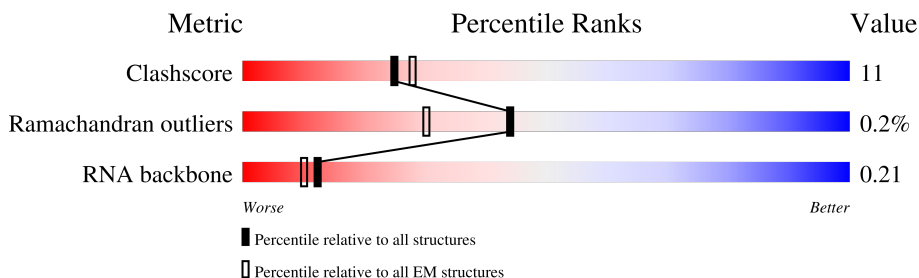

Metric	Whole archive (#Entries)	EM structures (#Entries)	Similar EM resolution (#Entries, resolution range(Å))
Clashscore	229148	23984	-
Ramachandran outliers	224038	23583	-
RNA backbone	8273	3508	-
Q-score	-	25397	444 (6.70 - 7.70)

The table below summarises the geometric issues observed across the polymeric chains and their fit to the map. The red, orange, yellow and green segments of the bar indicate the fraction of residues that contain outliers for ≥ 3 , 2, 1 and 0 types of geometric quality criteria respectively. A grey segment represents the fraction of residues that are not modelled. The numeric value for each fraction is indicated below the corresponding segment, with a dot representing fractions $\leq 5\%$. The upper red bar (where present) indicates the fraction of residues that have poor fit to the EM map (all-atom inclusion $< 40\%$). The numeric value is given above the bar.

Mol	Chain	Length	Quality of chain
1	0	309	
2	1	548	
3	2	395	
4	3	308	

Continued on next page...

Continued from previous page...

Mol	Chain	Length	Quality of chain
5	4	462	
6	5	71	
7	6	782	
8	7	760	
9	N	8	
10	Z	8	
11	A	1872	
12	B	1199	
13	D	1085	
13	d	1085	
14	E	800	
14	e	800	
15	F	677	
15	f	677	
16	G	349	
17	H	310	
18	I	264	
18	i	264	
19	J	218	
19	j	218	
20	L	161	
20	l	161	
21	O	109	
22	P	339	
23	Q	376	

Continued on next page...

Continued from previous page...

Mol	Chain	Length	Quality of chain
24	R	316	75% 14% 11%
25	S	517	26% 8% 66%
26	T	249	74% 15% 11%
27	U	439	23% 19% 58%
28	V	291	23% 33% 43%
29	X	99	36% 27% 36%
30	Y	99	37% 36% 26%
31	c	929	14% 12% 86%
32	k	211	46% 42% 54%
33	m	124	70% 52% 18% 30%
34	o	1970	57% 16% 26%
35	p	1174	80% 18% 2%
36	q	275	77% 17% 7%
37	r	142	62% 28% 10%
38	s	210	83% 17%
39	t	127	57% 7% 35%
40	u	172	68% 31% 1%
41	v	150	82% 17% 1%
42	w	125	70% 21% 9%
43	x	67	85% 15%
44	y	117	81% 17% 2%
45	z	58	59% 17% 24%

2 Entry composition [i](#)

There are 49 unique types of molecules in this entry. The entry contains 108679 atoms, of which 0 are hydrogens and 0 are deuteriums.

In the tables below, the AltConf column contains the number of residues with at least one atom in alternate conformation and the Trace column contains the number of residues modelled with at most 2 atoms.

- Molecule 1 is a protein called CDK-activating kinase assembly factor MAT1.

Mol	Chain	Residues	Atoms					AltConf	Trace
			Total	C	N	O	S		
1	0	171	1420	882	249	279	10	0	0

- Molecule 2 is a protein called General transcription factor IIH subunit 1.

Mol	Chain	Residues	Atoms					AltConf	Trace
			Total	C	N	O	S		
2	1	265	2167	1382	378	395	12	0	0

- Molecule 3 is a protein called General transcription factor IIH subunit 2.

Mol	Chain	Residues	Atoms					AltConf	Trace
			Total	C	N	O	S		
3	2	329	2567	1621	440	479	27	0	0

- Molecule 4 is a protein called General transcription factor IIH subunit 3.

Mol	Chain	Residues	Atoms					AltConf	Trace
			Total	C	N	O	S		
4	3	263	2066	1323	344	380	19	0	0

- Molecule 5 is a protein called General transcription factor IIH subunit 4.

Mol	Chain	Residues	Atoms					AltConf	Trace
			Total	C	N	O	S		
5	4	394	3189	2068	552	557	12	0	0

- Molecule 6 is a protein called General transcription factor IIH subunit 5.

Mol	Chain	Residues	Atoms					AltConf	Trace
			Total	C	N	O	S		
6	5	54	428	277	67	82	2	0	0

- Molecule 7 is a protein called General transcription and DNA repair factor IIIH helicase subunit XPB.

Mol	Chain	Residues	Atoms					AltConf	Trace
			Total	C	N	O	S		
7	6	605	4890	3127	848	885	30	0	0

- Molecule 8 is a protein called General transcription and DNA repair factor IIIH helicase subunit XPD.

Mol	Chain	Residues	Atoms					AltConf	Trace
			Total	C	N	O	S		
8	7	714	5751	3683	999	1040	29	0	0

- Molecule 9 is a protein called Alpha-amanitin.

Mol	Chain	Residues	Atoms					AltConf	Trace
			Total	C	N	O	S		
9	N	8	64	39	10	14	1	0	0

- Molecule 10 is a RNA chain called RNA.

Mol	Chain	Residues	Atoms					AltConf	Trace
			Total	C	N	O	P		
10	Z	8	175	75	24	66	10	0	0

- Molecule 11 is a protein called Transcription initiation factor TFIID subunit 1.

Mol	Chain	Residues	Atoms					AltConf	Trace
			Total	C	N	O	S		
11	A	559	4580	2924	795	834	27	0	0

- Molecule 12 is a protein called Transcription initiation factor TFIID subunit 2.

Mol	Chain	Residues	Atoms					AltConf	Trace
			Total	C	N	O	S		
12	B	963	7796	5011	1315	1412	58	0	0

- Molecule 13 is a protein called Transcription initiation factor TFIID subunit 4.

Mol	Chain	Residues	Atoms					AltConf	Trace
			Total	C	N	O	S		
13	D	164	1366	851	256	255	4	0	0

Continued on next page...

Continued from previous page...

Mol	Chain	Residues	Atoms					AltConf	Trace
13	d	158	Total	C	N	O	S	0	0
			1307	814	238	252	3		

- Molecule 14 is a protein called Transcription initiation factor TFIID subunit 5.

Mol	Chain	Residues	Atoms					AltConf	Trace
14	E	547	Total	C	N	O	S	0	0
			4376	2774	759	822	21		
14	e	539	Total	C	N	O	S	0	0
			4327	2746	748	814	19		

- Molecule 15 is a protein called Transcription initiation factor TFIID subunit 6.

Mol	Chain	Residues	Atoms					AltConf	Trace
15	F	412	Total	C	N	O	S	0	0
			3143	1994	548	583	18		
15	f	403	Total	C	N	O	S	0	0
			3081	1954	533	576	18		

- Molecule 16 is a protein called Transcription initiation factor TFIID subunit 7.

Mol	Chain	Residues	Atoms					AltConf	Trace
16	G	144	Total	C	N	O	S	0	0
			1171	742	215	210	4		

- Molecule 17 is a protein called Transcription initiation factor TFIID subunit 8.

Mol	Chain	Residues	Atoms					AltConf	Trace
17	H	209	Total	C	N	O	S	0	0
			1633	1034	283	311	5		

- Molecule 18 is a protein called Transcription initiation factor TFIID subunit 9.

Mol	Chain	Residues	Atoms					AltConf	Trace
18	I	120	Total	C	N	O	S	0	0
			959	610	166	177	6		
18	i	121	Total	C	N	O	S	0	0
			967	615	167	178	7		

- Molecule 19 is a protein called Transcription initiation factor TFIID subunit 10.

Mol	Chain	Residues	Atoms					AltConf	Trace
19	J	90	Total	C	N	O	S	0	0
			720	466	115	135	4		
19	j	95	Total	C	N	O	S	0	0
			759	488	124	143	4		

- Molecule 20 is a protein called Transcription initiation factor TFIID subunit 12.

Mol	Chain	Residues	Atoms					AltConf	Trace
20	L	76	Total	C	N	O	S	0	0
			622	388	109	122	3		
20	l	107	Total	C	N	O	S	0	0
			876	547	158	166	5		

- Molecule 21 is a protein called Transcription initiation factor IIA subunit 2.

Mol	Chain	Residues	Atoms					AltConf	Trace
21	O	99	Total	C	N	O	S	0	0
			806	510	142	151	3		

- Molecule 22 is a protein called TATA-box-binding protein.

Mol	Chain	Residues	Atoms					AltConf	Trace
22	P	179	Total	C	N	O	S	0	0
			1422	923	251	241	7		

- Molecule 23 is a protein called Transcription initiation factor IIA beta chain.

Mol	Chain	Residues	Atoms					AltConf	Trace
23	Q	113	Total	C	N	O	S	0	0
			930	585	152	189	4		

- Molecule 24 is a protein called Transcription initiation factor IIB.

Mol	Chain	Residues	Atoms					AltConf	Trace
24	R	282	Total	C	N	O	S	0	0
			2167	1353	384	412	18		

- Molecule 25 is a protein called General transcription factor IIF subunit 1.

Mol	Chain	Residues	Atoms					AltConf	Trace
25	S	176	Total	C	N	O	S	0	0
			1461	921	268	268	4		

- Molecule 26 is a protein called General transcription factor IIF subunit 2.

Mol	Chain	Residues	Atoms					AltConf	Trace
			Total	C	N	O	S		
26	T	222	1788	1127	320	338	3	0	0

- Molecule 27 is a protein called General transcription factor IIE subunit 1.

Mol	Chain	Residues	Atoms					AltConf	Trace
			Total	C	N	O	S		
27	U	184	1520	957	272	280	11	0	0

- Molecule 28 is a protein called Transcription initiation factor IIE subunit beta.

Mol	Chain	Residues	Atoms					AltConf	Trace
			Total	C	N	O	S		
28	V	165	1357	865	235	253	4	0	0

- Molecule 29 is a DNA chain called non-template DNA.

Mol	Chain	Residues	Atoms					AltConf	Trace
			Total	C	N	O	P		
29	X	63	1305	616	251	375	63	0	0

- Molecule 30 is a DNA chain called template DNA.

Mol	Chain	Residues	Atoms					AltConf	Trace
			Total	C	N	O	P		
30	Y	73	1484	706	263	442	73	0	0

- Molecule 31 is a protein called Transcription initiation factor TFIID subunit 3.

Mol	Chain	Residues	Atoms					AltConf	Trace
			Total	C	N	O	S		
31	c	127	1011	638	174	193	6	0	0

- Molecule 32 is a protein called Transcription initiation factor TFIID subunit 11.

Mol	Chain	Residues	Atoms					AltConf	Trace
			Total	C	N	O	S		
32	k	98	785	499	142	139	5	0	0

- Molecule 33 is a protein called Transcription initiation factor TFIID subunit 13.

Mol	Chain	Residues	Atoms					AltConf	Trace
33	m	87	Total	C	N	O	S	0	0
			724	456	131	131	6		

- Molecule 34 is a protein called DNA-directed RNA polymerase subunit.

Mol	Chain	Residues	Atoms					AltConf	Trace
34	o	1452	Total	C	N	O	S	0	0
			11510	7235	2056	2146	73		

- Molecule 35 is a protein called DNA-directed RNA polymerase subunit beta.

Mol	Chain	Residues	Atoms					AltConf	Trace
35	p	1149	Total	C	N	O	S	0	0
			9175	5796	1614	1701	64		

- Molecule 36 is a protein called DNA-directed RNA polymerase II subunit RPB3.

Mol	Chain	Residues	Atoms					AltConf	Trace
36	q	257	Total	C	N	O	S	0	0
			2059	1294	351	408	6		

- Molecule 37 is a protein called DNA-directed RNA polymerase II subunit RPB4.

Mol	Chain	Residues	Atoms					AltConf	Trace
37	r	128	Total	C	N	O	S	0	0
			1050	656	178	212	4		

- Molecule 38 is a protein called DNA-directed RNA polymerase II subunit E.

Mol	Chain	Residues	Atoms					AltConf	Trace
38	s	209	Total	C	N	O	S	0	0
			1720	1089	300	323	8		

- Molecule 39 is a protein called DNA-directed RNA polymerase II subunit F.

Mol	Chain	Residues	Atoms					AltConf	Trace
39	t	82	Total	C	N	O	S	0	0
			657	418	113	121	5		

- Molecule 40 is a protein called DNA-directed RNA polymerase II subunit RPB7.

Mol	Chain	Residues	Atoms					AltConf	Trace
40	u	171	Total	C	N	O	S	0	0
			1351	875	219	249	8		

- Molecule 41 is a protein called DNA-directed RNA polymerases I, II, and III subunit RPABC3.

Mol	Chain	Residues	Atoms					AltConf	Trace
41	v	148	Total	C	N	O	S	0	0
			1186	750	194	237	5		

- Molecule 42 is a protein called DNA-directed RNA polymerase II subunit RPB9.

Mol	Chain	Residues	Atoms					AltConf	Trace
42	w	114	Total	C	N	O	S	0	0
			927	571	166	179	11		

- Molecule 43 is a protein called DNA-directed RNA polymerases I, II, and III subunit RPABC5.

Mol	Chain	Residues	Atoms					AltConf	Trace
43	x	67	Total	C	N	O	S	0	0
			533	345	90	92	6		

- Molecule 44 is a protein called DNA-directed RNA polymerase II subunit RPB11-a.

Mol	Chain	Residues	Atoms					AltConf	Trace
44	y	115	Total	C	N	O	S	0	0
			920	593	152	173	2		

- Molecule 45 is a protein called RPB12.

Mol	Chain	Residues	Atoms					AltConf	Trace
45	z	44	Total	C	N	O	S	0	0
			372	231	72	63	6		

- Molecule 46 is ZINC ION (CCD ID: ZN) (formula: Zn).

Mol	Chain	Residues	Atoms		AltConf
46	0	2	Total	Zn	0
			2	2	
46	2	3	Total	Zn	0
			3	3	
46	3	2	Total	Zn	0
			2	2	

Continued on next page...

Continued from previous page...

Mol	Chain	Residues	Atoms		AltConf
46	R	1	Total	Zn	0
			1	1	
46	U	1	Total	Zn	0
			1	1	
46	o	2	Total	Zn	0
			2	2	
46	p	1	Total	Zn	0
			1	1	
46	q	1	Total	Zn	0
			1	1	
46	w	2	Total	Zn	0
			2	2	
46	x	1	Total	Zn	0
			1	1	
46	z	1	Total	Zn	0
			1	1	

- Molecule 47 is IRON/SULFUR CLUSTER (CCD ID: SF4) (formula: Fe₄S₄) (labeled as "Ligand of Interest" by depositor).

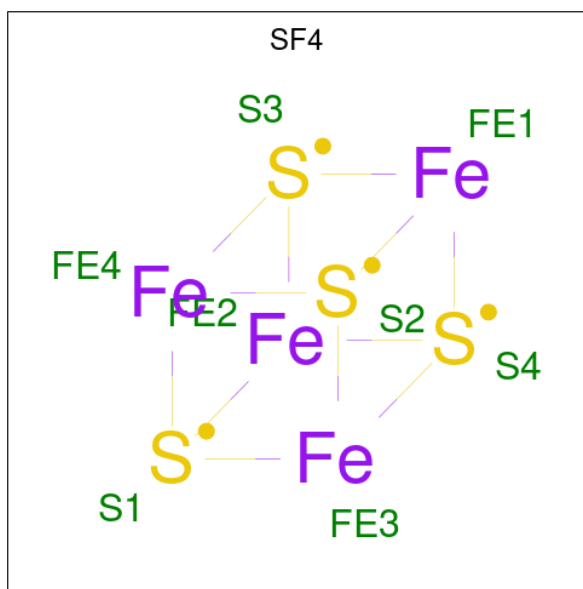

Mol	Chain	Residues	Atoms			AltConf
47	7	1	Total	Fe	S	0
			8	4	4	

- Molecule 48 is MAGNESIUM ION (CCD ID: MG) (formula: Mg).

Mol	Chain	Residues	Atoms		AltConf
48	o	1	Total	Mg	0
			1	1	

- Molecule 49 is [[(2 {S},3 {R},4 {S},5 {R})-5-(2-azanyl-6-oxidanylidene-3 {H}-purin-9-yl)-3-methoxy-4-oxidanyl-oxolan-2-yl]methoxy-oxidanyl-phosphoryl] phosphono hydrogen phosphate (CCD ID: W0F) (formula: C₁₁H₁₈N₅O₁₄P₃) (labeled as "Ligand of Interest" by depositor).

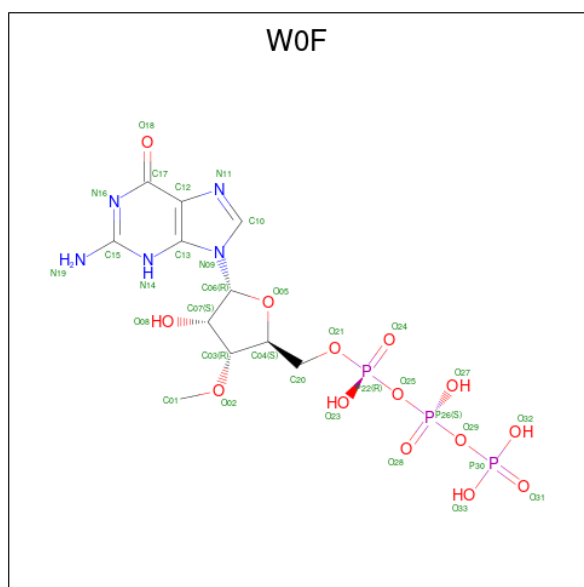

Mol	Chain	Residues	Atoms					AltConf
			Total	C	N	O	P	
49	p	1	33	11	5	14	3	0

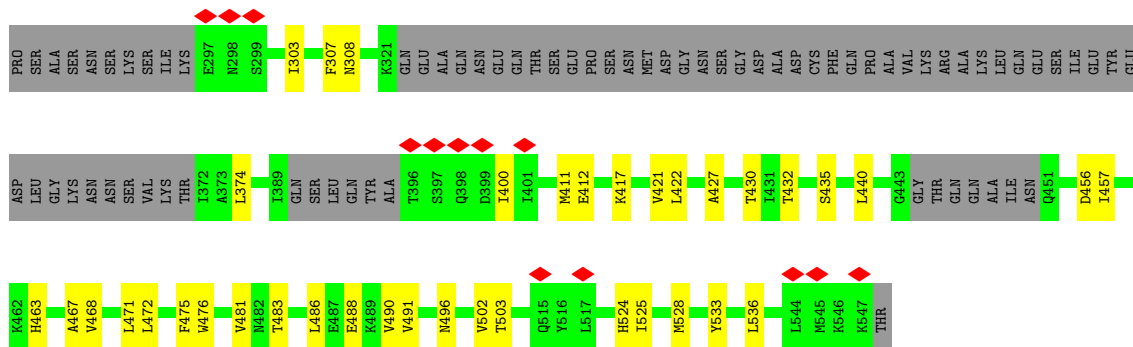

• Molecule 3: General transcription factor IIIH subunit 2

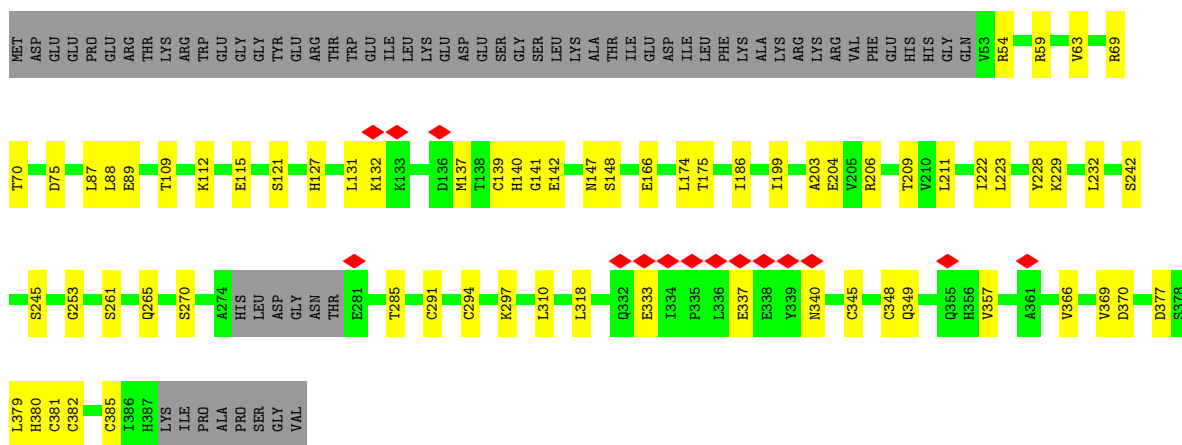

• Molecule 4: General transcription factor IIIH subunit 3

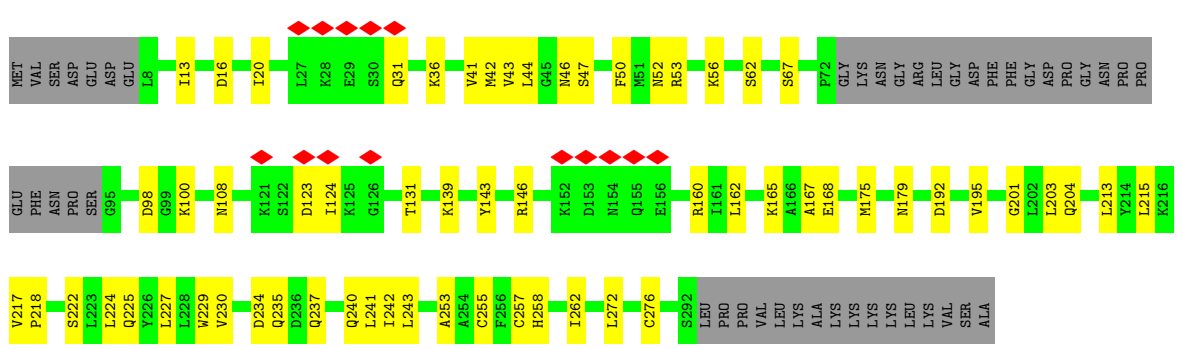

• Molecule 5: General transcription factor IIIH subunit 4

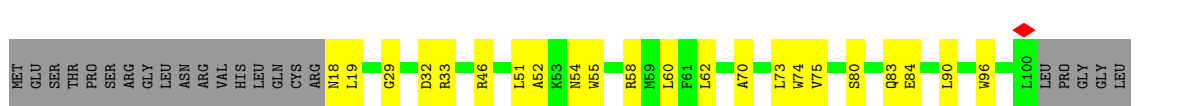

• Molecule 8: General transcription and DNA repair factor IIIH helicase subunit XPD

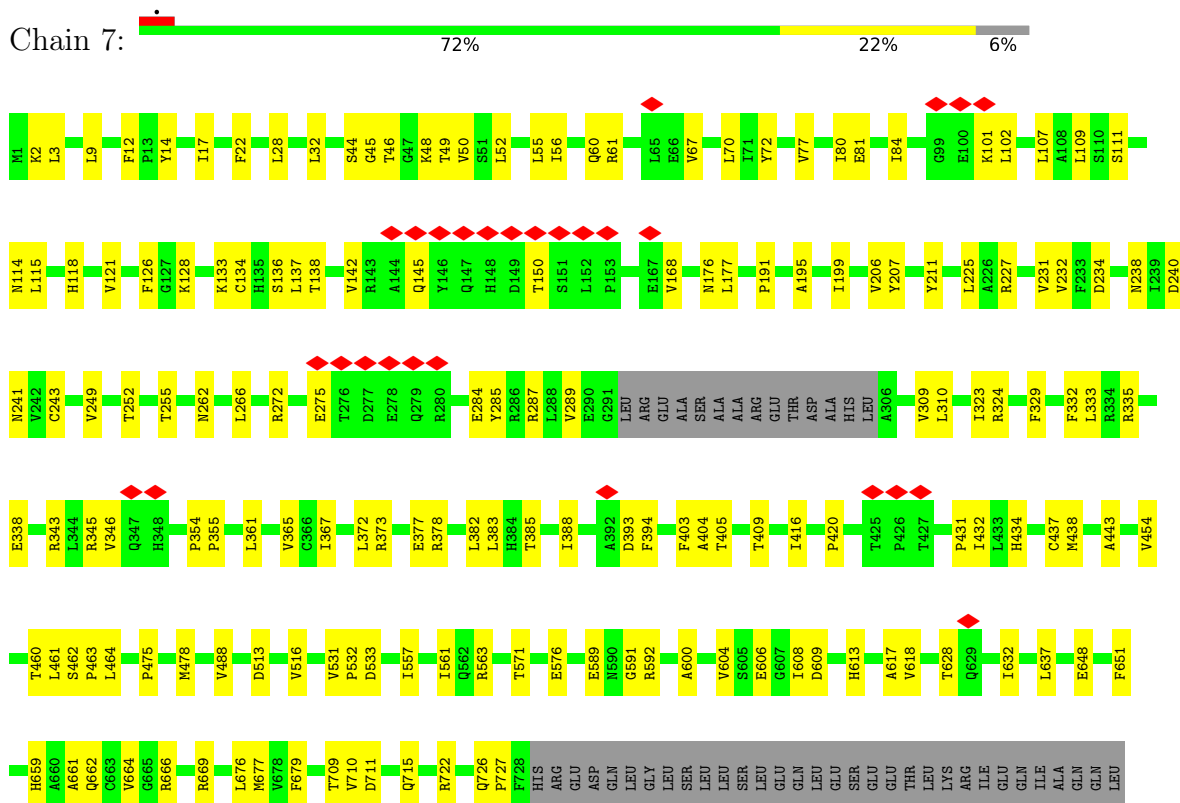

• Molecule 9: Alpha-amanitin

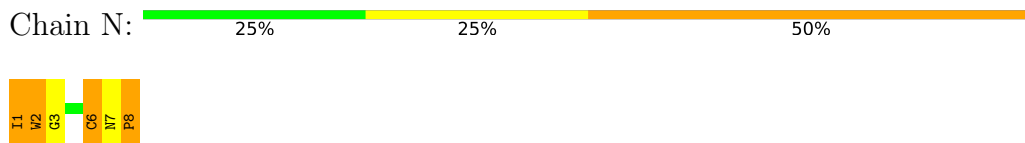

• Molecule 10: RNA



• Molecule 11: Transcription initiation factor TFIID subunit 1

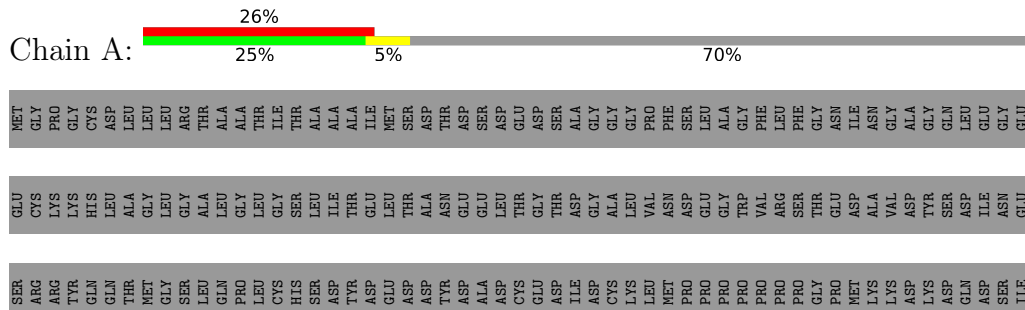

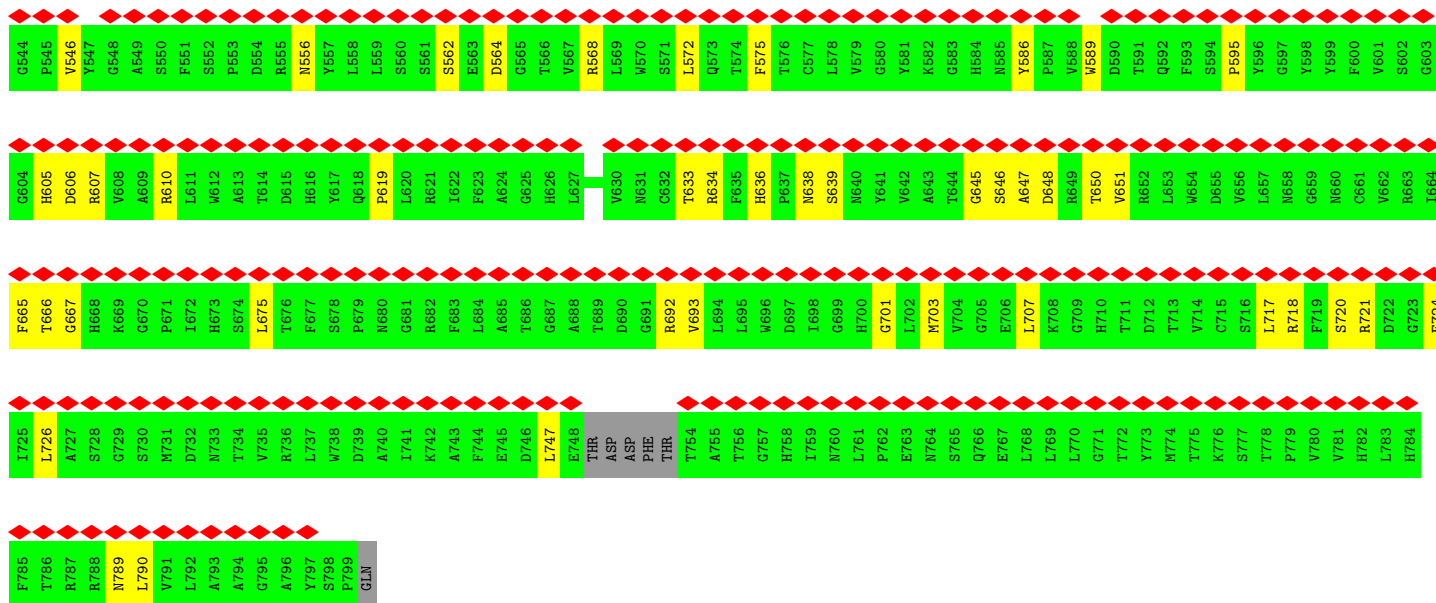

● Molecule 15: Transcription initiation factor TFIID subunit 6

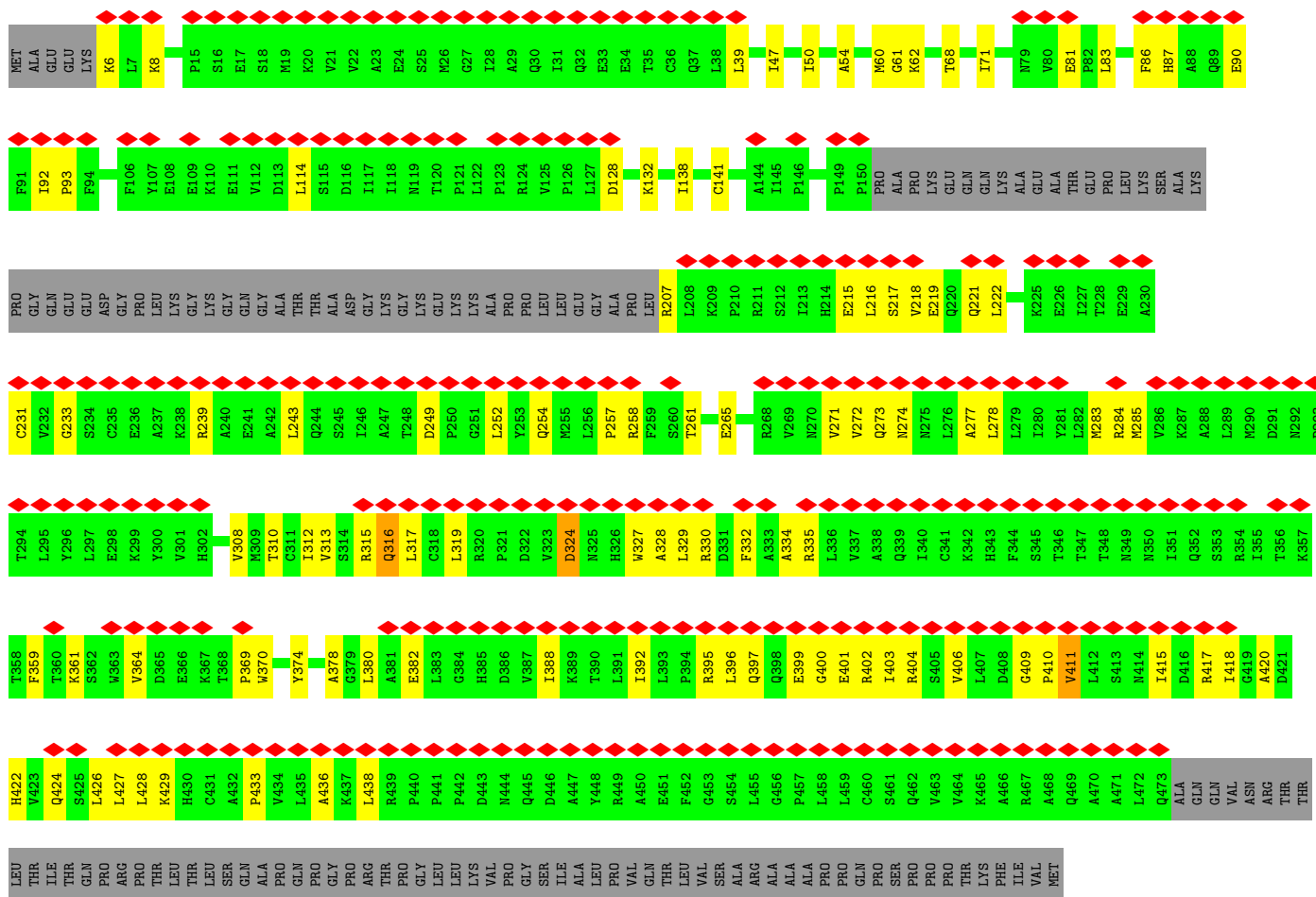
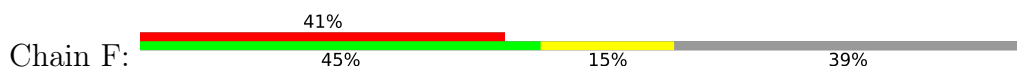

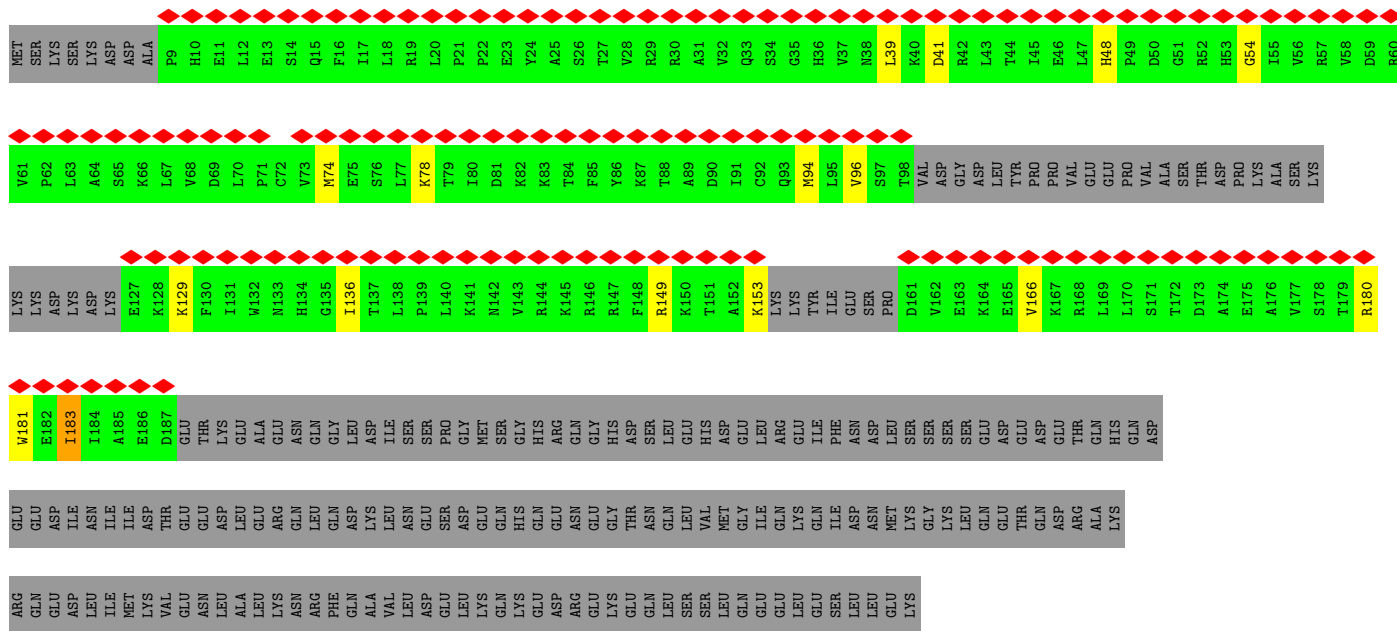

• Molecule 17: Transcription initiation factor TFIID subunit 8

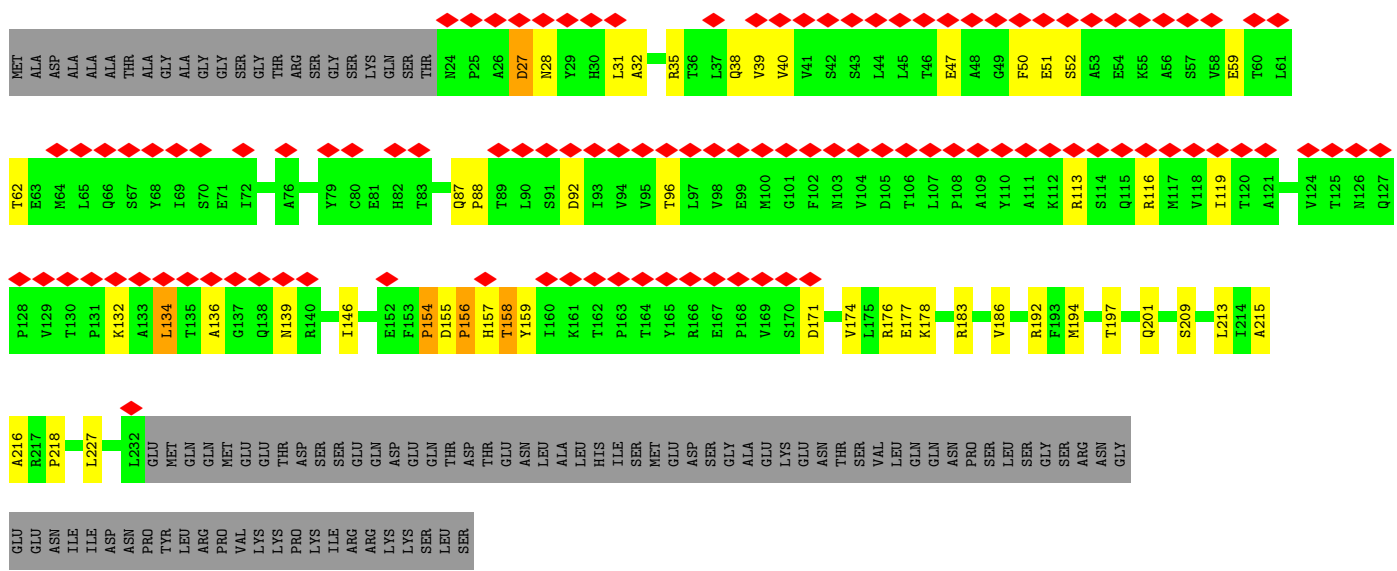

• Molecule 18: Transcription initiation factor TFIID subunit 9

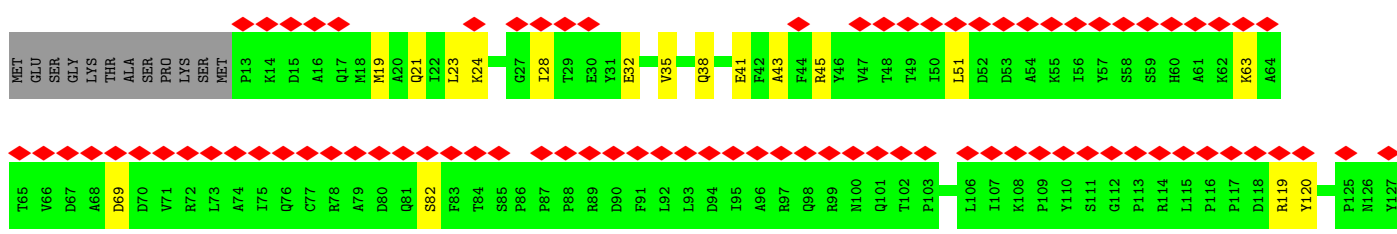
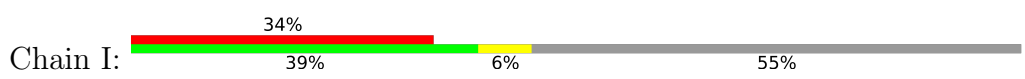

• Molecule 22: TATA-box-binding protein

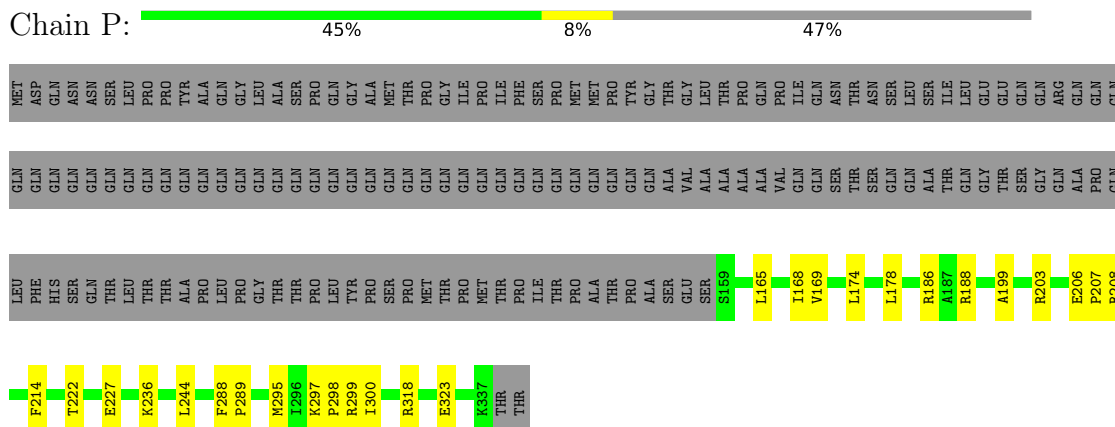

• Molecule 23: Transcription initiation factor IIA beta chain

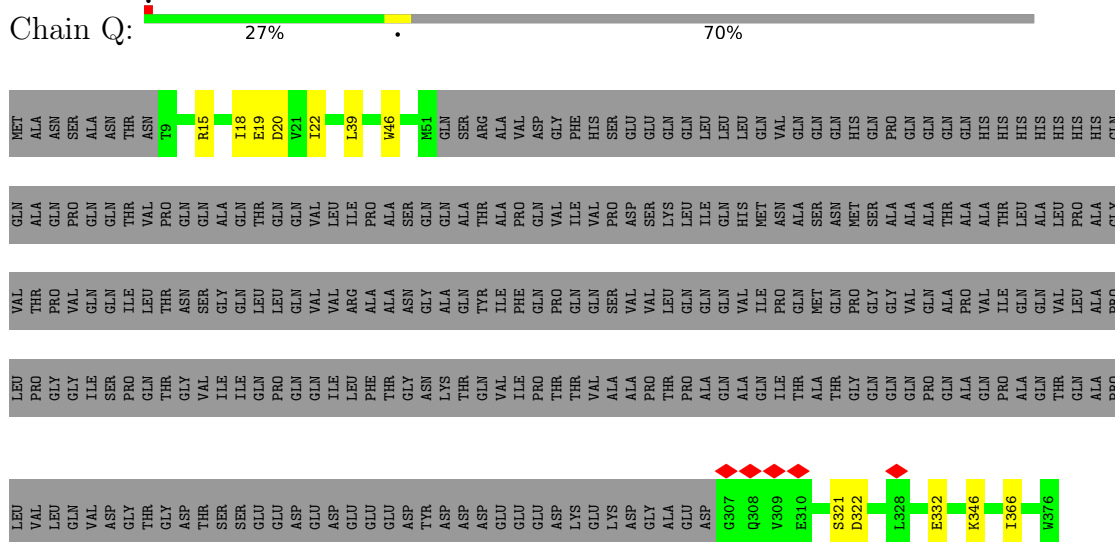

• Molecule 24: Transcription initiation factor IIB

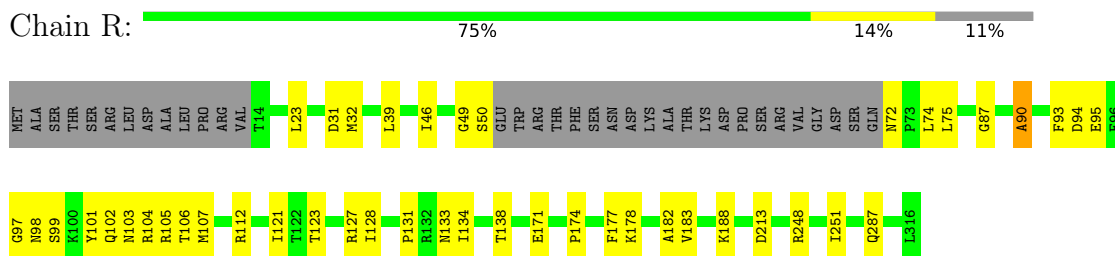

• Molecule 25: General transcription factor IIF subunit 1

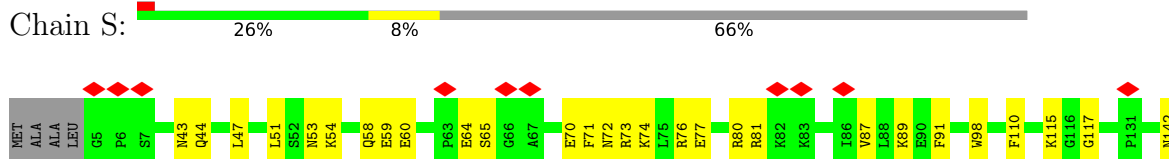

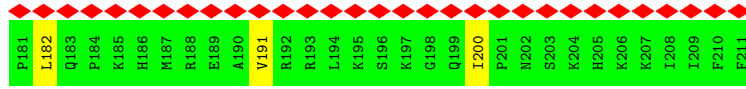

• Molecule 33: Transcription initiation factor TFIID subunit 13

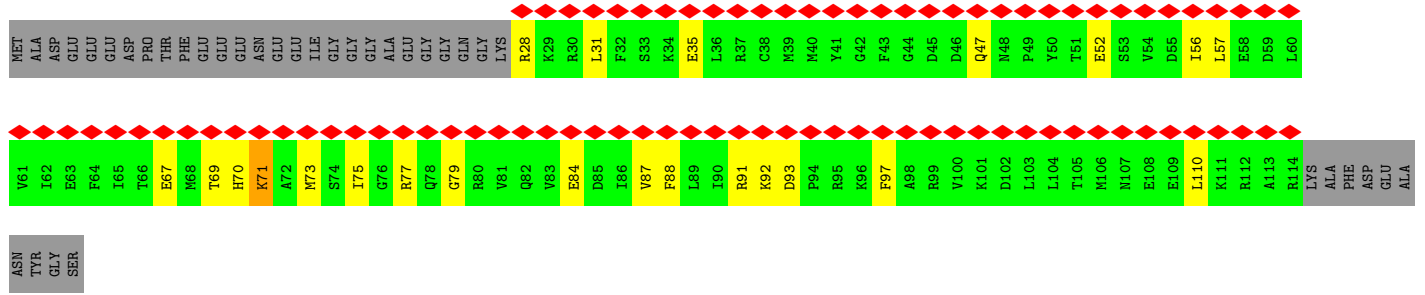

• Molecule 34: DNA-directed RNA polymerase subunit

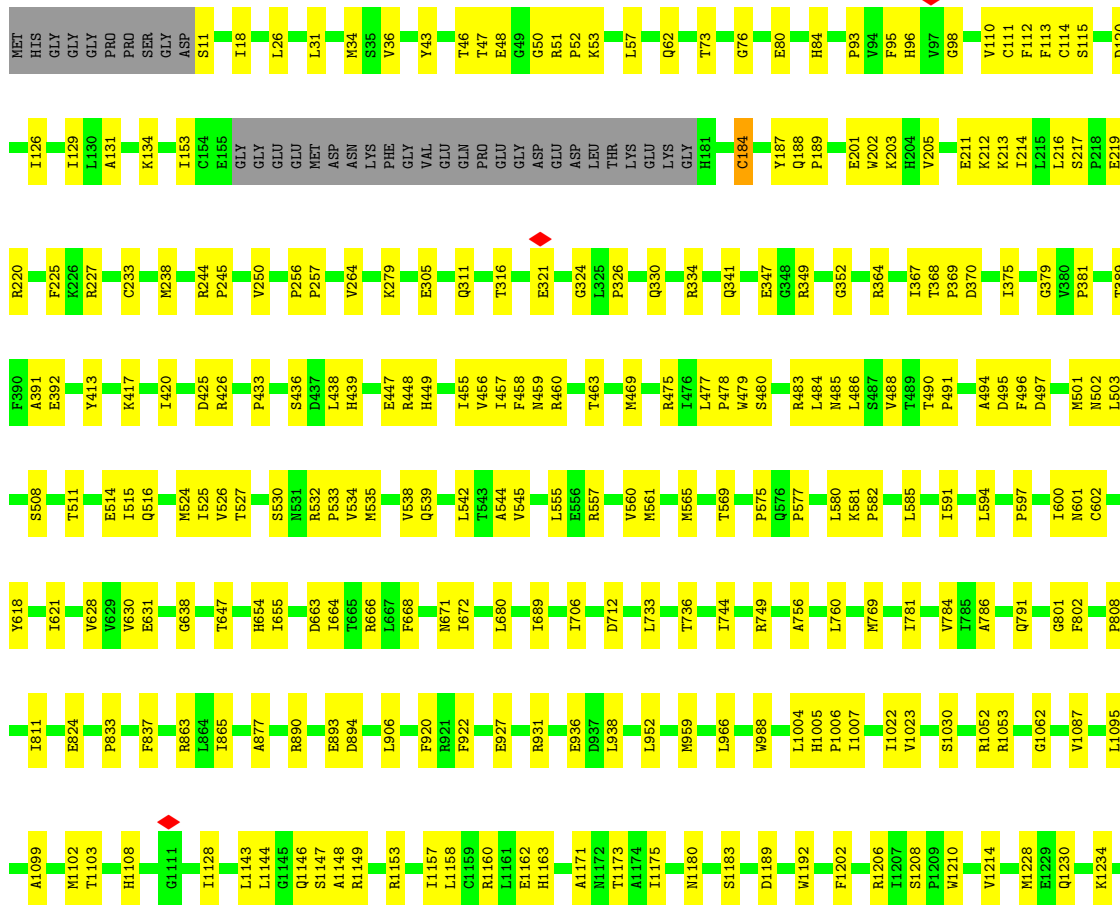



- Molecule 36: DNA-directed RNA polymerase II subunit RPB3

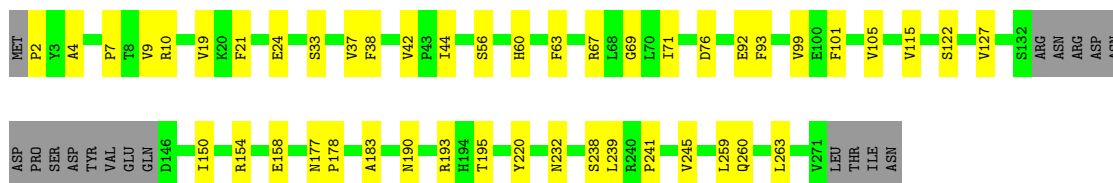
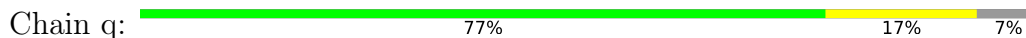

- Molecule 37: DNA-directed RNA polymerase II subunit RPB4



- Molecule 38: DNA-directed RNA polymerase II subunit E

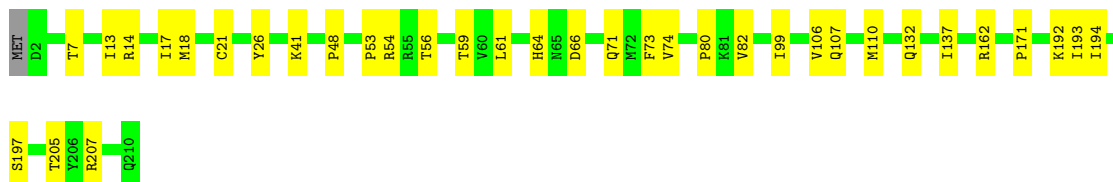
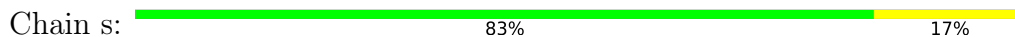

- Molecule 39: DNA-directed RNA polymerase II subunit F

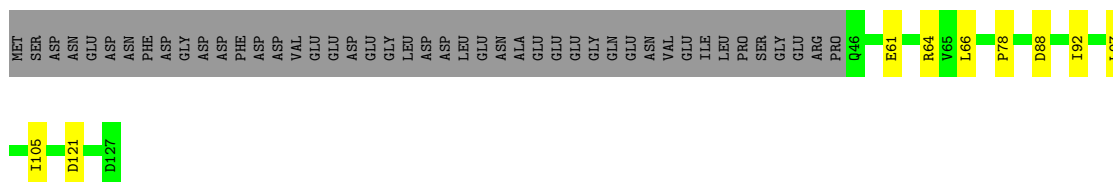

- Molecule 40: DNA-directed RNA polymerase II subunit RPB7



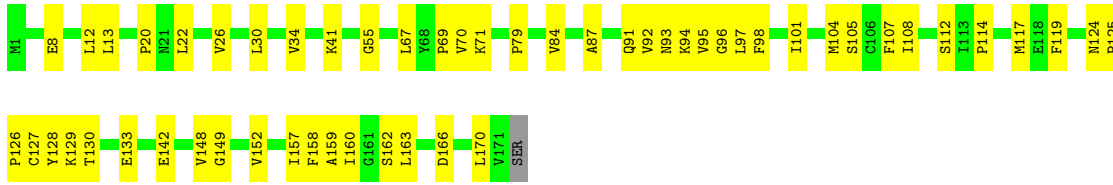

- Molecule 41: DNA-directed RNA polymerases I, II, and III subunit RPABC3

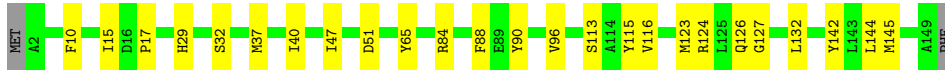
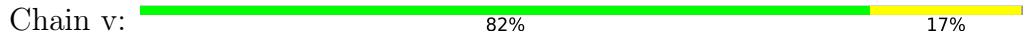

- Molecule 42: DNA-directed RNA polymerase II subunit RPB9

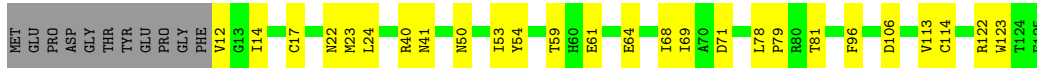

- Molecule 43: DNA-directed RNA polymerases I, II, and III subunit RPABC5

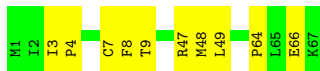
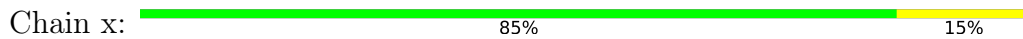

- Molecule 44: DNA-directed RNA polymerase II subunit RPB11-a

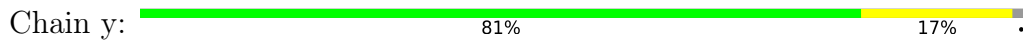

- Molecule 45: RPB12



4 Experimental information

Property	Value	Source
EM reconstruction method	SINGLE PARTICLE	Depositor
Imposed symmetry	POINT, Not provided	
Number of particles used	3241	Depositor
Resolution determination method	FSC 0.143 CUT-OFF	Depositor
CTF correction method	NONE	Depositor
Microscope	FEI TITAN KRIOS	Depositor
Voltage (kV)	300	Depositor
Electron dose ($e^-/\text{\AA}^2$)	50	Depositor
Minimum defocus (nm)	1500	Depositor
Maximum defocus (nm)	2500	Depositor
Magnification	Not provided	
Image detector	GATAN K3 (6k x 4k)	Depositor
Maximum map value	4.162	Depositor
Minimum map value	-1.128	Depositor
Average map value	0.037	Depositor
Map value standard deviation	0.180	Depositor
Recommended contour level	0.474	Depositor
Map size (\AA)	426.88, 426.88, 426.88	wwPDB
Map dimensions	320, 320, 320	wwPDB
Map angles ($^\circ$)	90.0, 90.0, 90.0	wwPDB
Pixel spacing (\AA)	1.334, 1.334, 1.334	Depositor

5 Model quality i

5.1 Standard geometry i

Bond lengths and bond angles in the following residue types are not validated in this section: W0F, ILX, MG, SF4, CSX, TRX, ATP, ZN, HYP, G2L

The Z score for a bond length (or angle) is the number of standard deviations the observed value is removed from the expected value. A bond length (or angle) with $|Z| > 5$ is considered an outlier worth inspection. RMSZ is the root-mean-square of all Z scores of the bond lengths (or angles).

Mol	Chain	Bond lengths		Bond angles	
		RMSZ	# Z >5	RMSZ	# Z >5
1	0	0.41	0/1437	0.71	3/1926 (0.2%)
2	1	0.20	0/2210	0.34	0/2975
3	2	0.19	0/2624	0.33	1/3555 (0.0%)
4	3	0.24	0/2103	0.36	0/2846
5	4	0.31	0/3262	0.45	1/4418 (0.0%)
6	5	0.41	0/433	0.79	1/585 (0.2%)
7	6	0.19	0/4994	0.33	0/6745
8	7	0.17	0/5875	0.30	0/7955
9	N	0.42	0/22	0.98	0/26
10	Z	0.21	0/131	0.41	0/200
11	A	0.63	0/4698	0.95	5/6345 (0.1%)
12	B	0.46	1/7993 (0.0%)	0.69	6/10836 (0.1%)
13	D	0.56	0/1379	0.88	3/1843 (0.2%)
13	d	0.47	0/1321	0.71	0/1772
14	E	0.45	1/4482 (0.0%)	0.72	3/6069 (0.0%)
14	e	0.55	1/4433 (0.0%)	0.77	0/6004
15	F	0.63	1/3201 (0.0%)	1.00	7/4347 (0.2%)
15	f	0.47	0/3140	0.80	6/4268 (0.1%)
16	G	0.68	0/1190	0.94	1/1601 (0.1%)
17	H	0.63	3/1673 (0.2%)	0.86	5/2285 (0.2%)
18	I	0.20	0/981	0.41	0/1332
18	i	0.22	0/989	0.40	0/1343
19	J	0.83	0/736	1.15	2/998 (0.2%)
19	j	0.73	0/775	0.96	0/1049
20	L	0.69	0/630	1.14	1/852 (0.1%)
20	l	0.59	0/888	0.88	0/1194
21	O	0.26	0/816	0.36	0/1105
22	P	0.11	0/1448	0.24	0/1948
23	Q	0.19	0/945	0.36	0/1274
24	R	0.18	0/2199	0.36	0/2967
25	S	0.15	0/1496	0.37	0/2013
26	T	0.13	0/1817	0.28	0/2445

Mol	Chain	Bond lengths		Bond angles	
		RMSZ	# Z >5	RMSZ	# Z >5
27	U	0.35	0/1545	0.69	1/2075 (0.0%)
28	V	0.24	0/1380	0.58	0/1854
29	X	0.28	0/1466	0.58	0/2261
30	Y	0.29	0/1659	0.54	0/2553
31	c	0.48	0/1035	0.67	0/1406
32	k	0.28	0/799	0.53	1/1070 (0.1%)
33	m	0.84	0/733	1.18	1/977 (0.1%)
34	o	0.26	0/11723	0.37	0/15830
35	p	0.30	0/9358	0.35	0/12633
36	q	0.30	0/2102	0.36	0/2857
37	r	0.10	0/1064	0.22	0/1428
38	s	0.24	0/1751	0.32	0/2366
39	t	0.25	0/667	0.29	0/901
40	u	0.15	0/1382	0.29	0/1874
41	v	0.24	0/1207	0.29	0/1628
42	w	0.21	0/948	0.31	0/1284
43	x	0.32	0/542	0.36	0/730
44	y	0.29	0/939	0.34	0/1271
45	z	0.21	0/377	0.32	0/500
All	All	0.38	7/110998 (0.0%)	0.58	48/150619 (0.0%)

Chiral center outliers are detected by calculating the chiral volume of a chiral center and verifying if the center is modelled as a planar moiety or with the opposite hand. A planarity outlier is detected by checking planarity of atoms in a peptide group, atoms in a mainchain group or atoms of a sidechain that are expected to be planar.

Mol	Chain	#Chirality outliers	#Planarity outliers
24	R	0	1

The worst 5 of 7 bond length outliers are listed below:

Mol	Chain	Res	Type	Atoms	Z	Observed(Å)	Ideal(Å)
17	H	28	ASN	C-O	-7.44	1.15	1.24
17	H	27	ASP	C-O	-7.01	1.15	1.24
17	H	31	LEU	C-O	-6.21	1.16	1.24
12	B	61	ASN	C-O	-6.15	1.18	1.24
14	E	524	LEU	C-O	5.71	1.30	1.24

The worst 5 of 48 bond angle outliers are listed below:

Mol	Chain	Res	Type	Atoms	Z	Observed(°)	Ideal(°)
1	0	55	LYS	CB-CA-C	-11.48	94.97	111.85

Continued on next page...

Continued from previous page...

Mol	Chain	Res	Type	Atoms	Z	Observed(°)	Ideal(°)
12	B	491	HIS	N-CA-C	-9.39	101.05	111.28
15	f	149	PRO	O-C-N	8.98	125.44	121.31
14	E	756	THR	N-CA-C	-8.37	103.20	113.50
17	H	32	ALA	N-CA-C	-8.25	102.25	111.07

There are no chirality outliers.

All (1) planarity outliers are listed below:

Mol	Chain	Res	Type	Group
24	R	106	THR	Peptide

5.2 Too-close contacts [i](#)

In the following table, the Non-H and H(model) columns list the number of non-hydrogen atoms and hydrogen atoms in the chain respectively. The H(added) column lists the number of hydrogen atoms added and optimized by MolProbity. The Clashes column lists the number of clashes within the asymmetric unit, whereas Symm-Clashes lists symmetry-related clashes.

Mol	Chain	Non-H	H(model)	H(added)	Clashes	Symm-Clashes
1	0	1420	0	1420	124	0
2	1	2167	0	2175	39	0
3	2	2567	0	2539	93	0
4	3	2066	0	2097	102	0
5	4	3189	0	3243	141	0
6	5	428	0	434	42	0
7	6	4890	0	4949	93	0
8	7	5751	0	5794	144	0
9	N	64	0	51	7	0
10	Z	175	0	83	4	0
11	A	4580	0	4502	99	0
12	B	7796	0	7751	116	0
13	D	1366	0	1390	73	0
13	d	1307	0	1318	15	0
14	E	4376	0	4256	74	0
14	e	4327	0	4197	61	0
15	F	3143	0	3093	98	0
15	f	3081	0	3012	69	0
16	G	1171	0	1222	16	0
17	H	1633	0	1621	38	0
18	I	959	0	969	13	0
18	i	967	0	977	10	0

Continued on next page...

Continued from previous page...

Mol	Chain	Non-H	H(model)	H(added)	Clashes	Symm-Clashes
19	J	720	0	719	13	0
19	j	759	0	759	14	0
20	L	622	0	620	19	0
20	l	876	0	893	10	0
21	O	806	0	818	18	0
22	P	1422	0	1514	20	0
23	Q	930	0	888	12	0
24	R	2167	0	2193	36	0
25	S	1461	0	1429	42	0
26	T	1788	0	1819	54	0
27	U	1520	0	1520	213	0
28	V	1357	0	1381	90	0
29	X	1305	0	707	33	0
30	Y	1484	0	823	42	0
31	c	1011	0	975	19	0
32	k	785	0	818	8	0
33	m	724	0	744	23	0
34	o	11510	0	11615	238	0
35	p	9175	0	9196	170	0
36	q	2059	0	2007	34	0
37	r	1050	0	1033	24	0
38	s	1720	0	1737	23	0
39	t	657	0	684	9	0
40	u	1351	0	1358	132	0
41	v	1186	0	1147	17	0
42	w	927	0	860	28	0
43	x	533	0	553	10	0
44	y	920	0	942	18	0
45	z	372	0	378	9	0
46	0	2	0	0	0	0
46	2	3	0	0	0	0
46	3	2	0	0	0	0
46	R	1	0	0	0	0
46	U	1	0	0	0	0
46	o	2	0	0	0	0
46	p	1	0	0	0	0
46	q	1	0	0	0	0
46	w	2	0	0	0	0
46	x	1	0	0	0	0
46	z	1	0	0	0	0
47	7	8	0	0	0	0
48	o	1	0	0	0	0

Continued on next page...

Continued from previous page...

Mol	Chain	Non-H	H(model)	H(added)	Clashes	Symm-Clashes
49	p	33	0	0	8	0
All	All	108679	0	107223	2271	0

The all-atom clashscore is defined as the number of clashes found per 1000 atoms (including hydrogen atoms). The all-atom clashscore for this structure is 11.

The worst 5 of 2271 close contacts within the same asymmetric unit are listed below, sorted by their clash magnitude.

Atom-1	Atom-2	Interatomic distance (Å)	Clash overlap (Å)
27:U:152:PHE:CE1	40:u:95:VAL:HB	1.25	1.66
27:U:139:LEU:HB2	40:u:160:ILE:CG1	1.23	1.60
1:0:41:ARG:CG	27:U:169:PRO:HG2	1.34	1.54
6:5:33:PHE:CE1	6:5:49:LEU:HD12	1.44	1.49
27:U:139:LEU:CB	40:u:160:ILE:HG12	1.42	1.49

There are no symmetry-related clashes.

5.3 Torsion angles [i](#)

5.3.1 Protein backbone [i](#)

In the following table, the Percentiles column shows the percent Ramachandran outliers of the chain as a percentile score with respect to all PDB entries followed by that with respect to all EM entries.

The Analysed column shows the number of residues for which the backbone conformation was analysed, and the total number of residues.

Mol	Chain	Analysed	Favoured	Allowed	Outliers	Percentiles	
1	0	169/309 (55%)	156 (92%)	13 (8%)	0	100	100
2	1	253/548 (46%)	243 (96%)	10 (4%)	0	100	100
3	2	325/395 (82%)	312 (96%)	13 (4%)	0	100	100
4	3	259/308 (84%)	253 (98%)	6 (2%)	0	100	100
5	4	384/462 (83%)	365 (95%)	19 (5%)	0	100	100
6	5	52/71 (73%)	48 (92%)	2 (4%)	2 (4%)	2	19
7	6	601/782 (77%)	573 (95%)	27 (4%)	1 (0%)	43	78
8	7	710/760 (93%)	682 (96%)	28 (4%)	0	100	100

Continued on next page...

Continued from previous page...

Mol	Chain	Analysed	Favoured	Allowed	Outliers	Percentiles	
9	N	4/8 (50%)	3 (75%)	1 (25%)	0	100	100
11	A	543/1872 (29%)	519 (96%)	23 (4%)	1 (0%)	43	78
12	B	959/1199 (80%)	911 (95%)	48 (5%)	0	100	100
13	D	158/1085 (15%)	153 (97%)	5 (3%)	0	100	100
13	d	154/1085 (14%)	150 (97%)	4 (3%)	0	100	100
14	E	541/800 (68%)	518 (96%)	22 (4%)	1 (0%)	43	78
14	e	531/800 (66%)	482 (91%)	48 (9%)	1 (0%)	43	78
15	F	408/677 (60%)	392 (96%)	15 (4%)	1 (0%)	43	78
15	f	399/677 (59%)	379 (95%)	20 (5%)	0	100	100
16	G	138/349 (40%)	135 (98%)	3 (2%)	0	100	100
17	H	207/310 (67%)	189 (91%)	13 (6%)	5 (2%)	4	27
18	I	118/264 (45%)	115 (98%)	3 (2%)	0	100	100
18	i	119/264 (45%)	115 (97%)	4 (3%)	0	100	100
19	J	86/218 (39%)	82 (95%)	4 (5%)	0	100	100
19	j	91/218 (42%)	85 (93%)	4 (4%)	2 (2%)	5	29
20	L	74/161 (46%)	72 (97%)	2 (3%)	0	100	100
20	l	105/161 (65%)	100 (95%)	5 (5%)	0	100	100
21	O	97/109 (89%)	95 (98%)	2 (2%)	0	100	100
22	P	177/339 (52%)	175 (99%)	2 (1%)	0	100	100
23	Q	109/376 (29%)	102 (94%)	7 (6%)	0	100	100
24	R	278/316 (88%)	261 (94%)	15 (5%)	2 (1%)	18	56
25	S	174/517 (34%)	161 (92%)	12 (7%)	1 (1%)	21	59
26	T	218/249 (88%)	211 (97%)	7 (3%)	0	100	100
27	U	180/439 (41%)	153 (85%)	26 (14%)	1 (1%)	21	59
28	V	163/291 (56%)	139 (85%)	24 (15%)	0	100	100
31	c	125/929 (14%)	116 (93%)	9 (7%)	0	100	100
32	k	96/211 (46%)	91 (95%)	5 (5%)	0	100	100
33	m	85/124 (68%)	82 (96%)	3 (4%)	0	100	100
34	o	1448/1970 (74%)	1396 (96%)	47 (3%)	5 (0%)	36	72
35	p	1145/1174 (98%)	1107 (97%)	38 (3%)	0	100	100
36	q	253/275 (92%)	247 (98%)	6 (2%)	0	100	100

Continued on next page...

Continued from previous page...

Mol	Chain	Analysed	Favoured	Allowed	Outliers	Percentiles	
37	r	126/142 (89%)	126 (100%)	0	0	100	100
38	s	207/210 (99%)	203 (98%)	4 (2%)	0	100	100
39	t	80/127 (63%)	79 (99%)	1 (1%)	0	100	100
40	u	169/172 (98%)	167 (99%)	2 (1%)	0	100	100
41	v	146/150 (97%)	142 (97%)	4 (3%)	0	100	100
42	w	112/125 (90%)	108 (96%)	4 (4%)	0	100	100
43	x	65/67 (97%)	63 (97%)	2 (3%)	0	100	100
44	y	113/117 (97%)	110 (97%)	3 (3%)	0	100	100
45	z	42/58 (72%)	40 (95%)	2 (5%)	0	100	100
All	All	12996/22270 (58%)	12406 (96%)	567 (4%)	23 (0%)	44	78

5 of 23 Ramachandran outliers are listed below:

Mol	Chain	Res	Type
6	5	48	GLU
14	E	523	VAL
17	H	156	PRO
25	S	87	VAL
34	o	1103	THR

5.3.2 Protein sidechains [i](#)

There are no protein residues with a non-rotameric sidechain to report in this entry.

5.3.3 RNA [i](#)

Mol	Chain	Analysed	Backbone Outliers	Pucker Outliers
10	Z	6/8 (75%)	4 (66%)	0

All (4) RNA backbone outliers are listed below:

Mol	Chain	Res	Type
10	Z	3	C
10	Z	4	U
10	Z	6	C
10	Z	8	G2L

There are no RNA pucker outliers to report.

5.4 Non-standard residues in protein, DNA, RNA chains [i](#)

5 non-standard protein/DNA/RNA residues are modelled in this entry.

In the following table, the Counts columns list the number of bonds (or angles) for which Mogul statistics could be retrieved, the number of bonds (or angles) that are observed in the model and the number of bonds (or angles) that are defined in the Chemical Component Dictionary. The Link column lists molecule types, if any, to which the group is linked. The Z score for a bond length (or angle) is the number of standard deviations the observed value is removed from the expected value. A bond length (or angle) with $|Z| > 2$ is considered an outlier worth inspection. RMSZ is the root-mean-square of all Z scores of the bond lengths (or angles).

Mol	Type	Chain	Res	Link	Bond lengths			Bond angles		
					Counts	RMSZ	# Z > 2	Counts	RMSZ	# Z > 2
9	TRX	N	2	9	15,16,17	1.04	1 (6%)	17,22,24	1.01	1 (5%)
10	G2L	Z	8	30,10	23,26,30	1.21	3 (13%)	31,38,44	2.11	7 (22%)
9	ILX	N	1	9	8,9,10	0.64	0	8,11,13	1.41	1 (12%)
9	CSX	N	6	9	3,6,7	1.11	0	1,6,8	2.21	1 (100%)
9	HYP	N	8	9	7,8,9	0.84	0	5,10,12	2.37	2 (40%)

In the following table, the Chirals column lists the number of chiral outliers, the number of chiral centers analysed, the number of these observed in the model and the number defined in the Chemical Component Dictionary. Similar counts are reported in the Torsion and Rings columns. '-' means no outliers of that kind were identified.

Mol	Type	Chain	Res	Link	Chirals	Torsions	Rings
9	TRX	N	2	9	-	2/5/6/8	0/2/2/2
10	G2L	Z	8	30,10	-	2/9/27/31	0/3/3/3
9	ILX	N	1	9	-	7/11/12/14	-
9	CSX	N	6	9	-	2/2/5/7	-
9	HYP	N	8	9	-	0/0/11/13	0/1/1/1

All (4) bond length outliers are listed below:

Mol	Chain	Res	Type	Atoms	Z	Observed(Å)	Ideal(Å)
10	Z	8	G2L	C5-C4	3.17	1.47	1.38
10	Z	8	G2L	C6-N1	-2.41	1.34	1.38
9	N	2	TRX	CD2-CE2	2.17	1.44	1.41
10	Z	8	G2L	C5-N7	-2.10	1.34	1.39

The worst 5 of 12 bond angle outliers are listed below:

Mol	Chain	Res	Type	Atoms	Z	Observed(°)	Ideal(°)
10	Z	8	G2L	C5-C4-N3	-6.18	118.55	128.39
10	Z	8	G2L	C2-N3-C4	5.04	120.98	112.30
10	Z	8	G2L	N9-C4-N3	4.58	135.11	125.95
9	N	8	HYP	CB-CG-CD	3.52	107.08	103.16
9	N	8	HYP	O-C-CA	-3.32	116.23	124.77

There are no chirality outliers.

5 of 13 torsion outliers are listed below:

Mol	Chain	Res	Type	Atoms
9	N	1	ILX	C-CA-CB-CG2
9	N	1	ILX	OD1-CD1-CG1-CB
9	N	1	ILX	OD1-CD1-CG1-OG1
9	N	6	CSX	N-CA-CB-SG
9	N	6	CSX	C-CA-CB-SG

There are no ring outliers.

5 monomers are involved in 8 short contacts:

Mol	Chain	Res	Type	Clashes	Symm-Clashes
9	N	2	TRX	1	0
10	Z	8	G2L	3	0
9	N	1	ILX	2	0
9	N	6	CSX	1	0
9	N	8	HYP	1	0

5.5 Carbohydrates [i](#)

There are no oligosaccharides in this entry.

5.6 Ligand geometry [i](#)

Of 20 ligands modelled in this entry, 18 are monoatomic - leaving 2 for Mogul analysis.

In the following table, the Counts columns list the number of bonds (or angles) for which Mogul statistics could be retrieved, the number of bonds (or angles) that are observed in the model and the number of bonds (or angles) that are defined in the Chemical Component Dictionary. The Link column lists molecule types, if any, to which the group is linked. The Z score for a bond length (or angle) is the number of standard deviations the observed value is removed from the

expected value. A bond length (or angle) with $|Z| > 2$ is considered an outlier worth inspection. RMSZ is the root-mean-square of all Z scores of the bond lengths (or angles).

Mol	Type	Chain	Res	Link	Bond lengths			Bond angles		
					Counts	RMSZ	$\# Z > 2$	Counts	RMSZ	$\# Z > 2$
49	W0F	p	1201	-	34,35,35	4.04	14 (41%)	43,55,55	3.45	17 (39%)
47	SF4	7	1000	8	0,12,12	-	-	-	-	-

In the following table, the Chirals column lists the number of chiral outliers, the number of chiral centers analysed, the number of these observed in the model and the number defined in the Chemical Component Dictionary. Similar counts are reported in the Torsion and Rings columns. '-' means no outliers of that kind were identified.

Mol	Type	Chain	Res	Link	Chirals	Torsions	Rings
49	W0F	p	1201	-	-	3/24/40/40	0/3/3/3
47	SF4	7	1000	8	-	-	0/6/5/5

The worst 5 of 14 bond length outliers are listed below:

Mol	Chain	Res	Type	Atoms	Z	Observed(Å)	Ideal(Å)
49	p	1201	W0F	P26-O29	13.69	1.74	1.59
49	p	1201	W0F	C03-C04	-9.79	1.27	1.52
49	p	1201	W0F	P22-O25	8.41	1.68	1.59
49	p	1201	W0F	O05-C04	6.88	1.60	1.45
49	p	1201	W0F	O05-C06	-5.97	1.28	1.42

The worst 5 of 17 bond angle outliers are listed below:

Mol	Chain	Res	Type	Atoms	Z	Observed(°)	Ideal(°)
49	p	1201	W0F	O05-C06-N09	-14.57	75.34	108.36
49	p	1201	W0F	C07-C06-N09	8.29	136.31	113.25
49	p	1201	W0F	O05-C04-C03	-5.78	92.73	104.92
49	p	1201	W0F	O27-P26-O25	-5.28	93.00	107.27
49	p	1201	W0F	O05-C04-C20	4.92	125.08	109.33

There are no chirality outliers.

All (3) torsion outliers are listed below:

Mol	Chain	Res	Type	Atoms
49	p	1201	W0F	C20-O21-P22-O24
49	p	1201	W0F	C20-O21-P22-O25
49	p	1201	W0F	C03-C04-C20-O21

There are no ring outliers.

1 monomer is involved in 8 short contacts:

Mol	Chain	Res	Type	Clashes	Symm-Clashes
49	p	1201	W0F	8	0

The following is a two-dimensional graphical depiction of Mogul quality analysis of bond lengths, bond angles, torsion angles, and ring geometry for all instances of the Ligand of Interest. In addition, ligands with molecular weight > 250 and outliers as shown on the validation Tables will also be included. For torsion angles, if less than 5% of the Mogul distribution of torsion angles is within 10 degrees of the torsion angle in question, then that torsion angle is considered an outlier. Any bond that is central to one or more torsion angles identified as an outlier by Mogul will be highlighted in the graph. For rings, the root-mean-square deviation (RMSD) between the ring in question and similar rings identified by Mogul is calculated over all ring torsion angles. If the average RMSD is greater than 60 degrees and the minimal RMSD between the ring in question and any Mogul-identified rings is also greater than 60 degrees, then that ring is considered an outlier. The outliers are highlighted in purple. The color gray indicates Mogul did not find sufficient equivalents in the CSD to analyse the geometry.

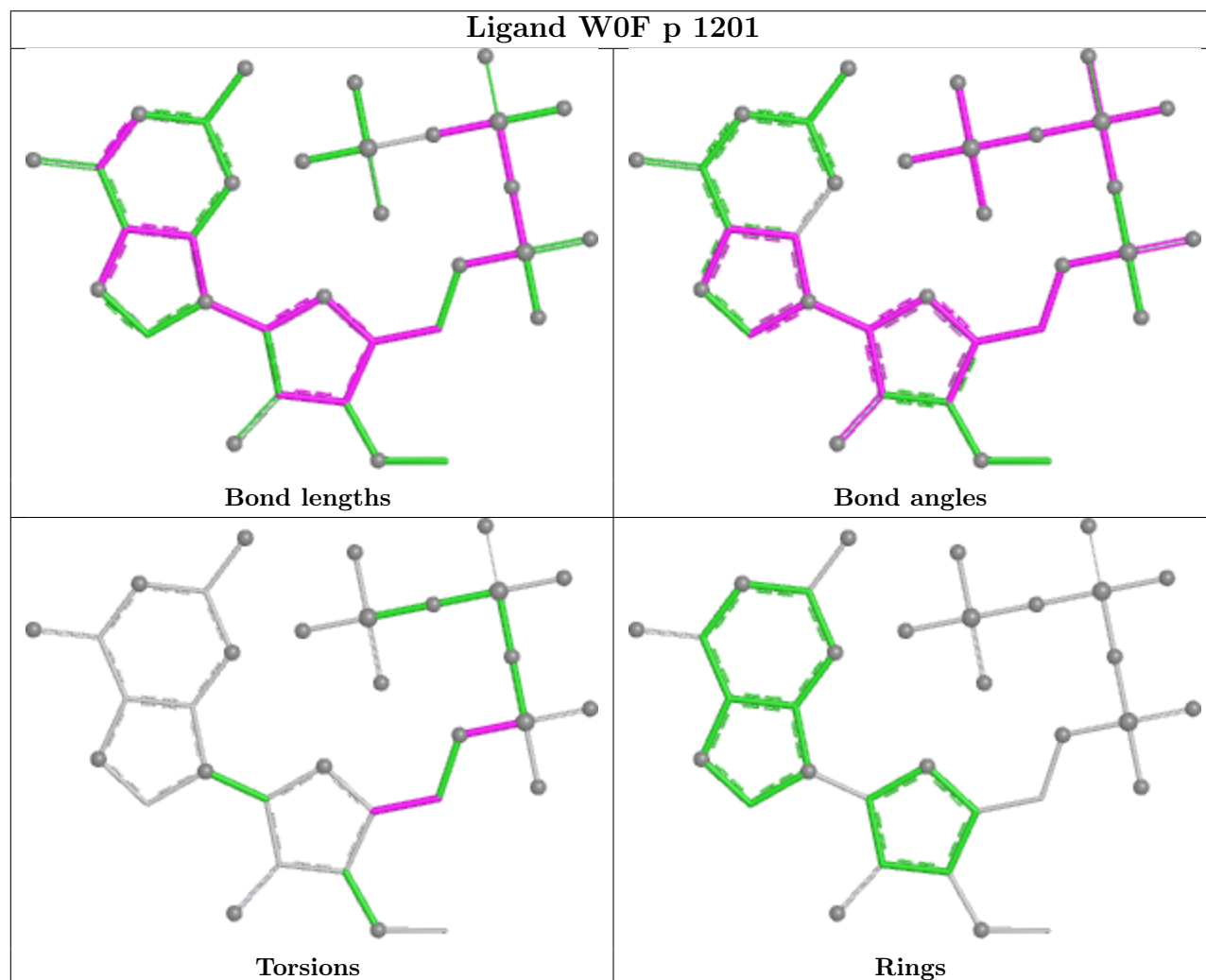

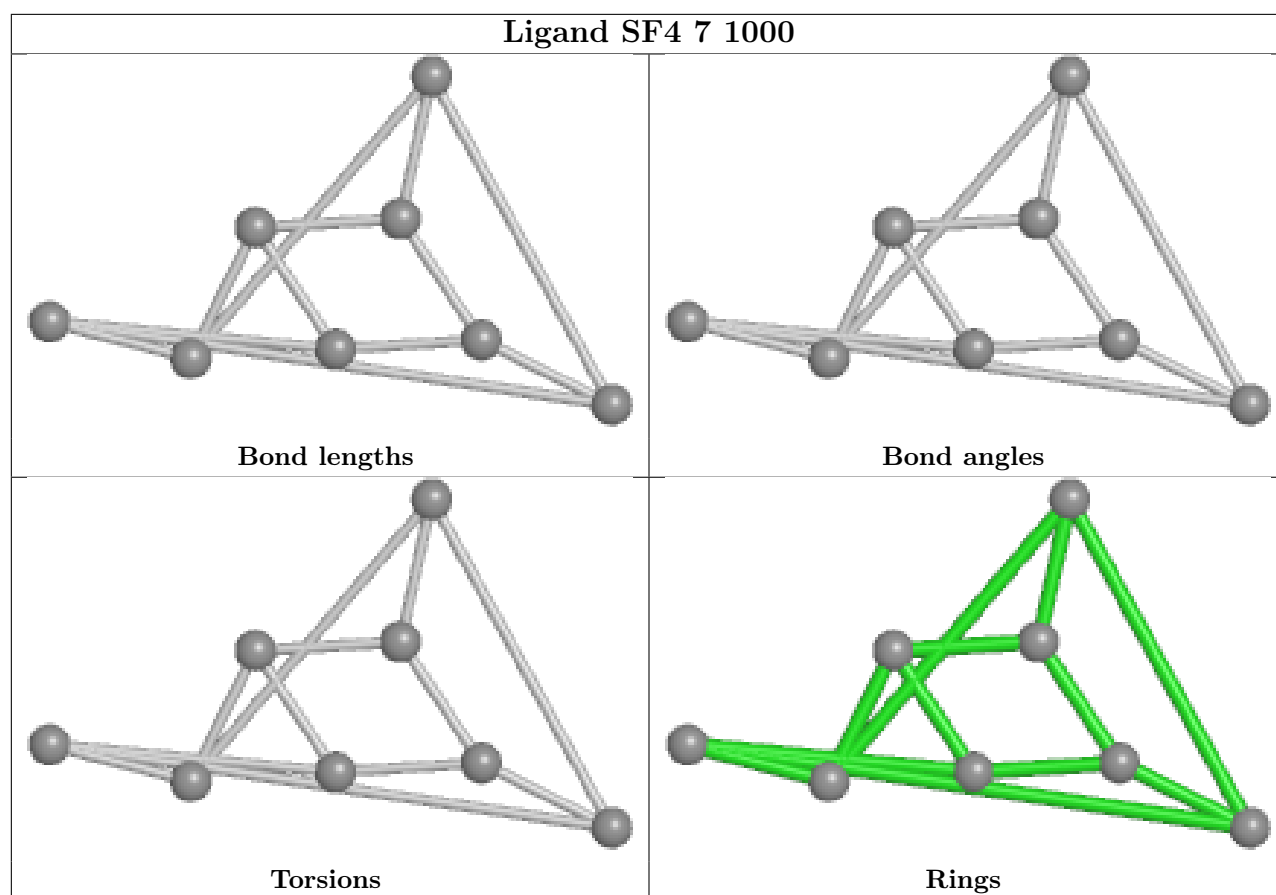

5.7 Other polymers [i](#)

There are no such residues in this entry.

5.8 Polymer linkage issues [i](#)

There are no chain breaks in this entry.

6 Map visualisation [i](#)

This section contains visualisations of the EMDB entry EMD-37402. These allow visual inspection of the internal detail of the map and identification of artifacts.

Images derived from a raw map, generated by summing the deposited half-maps, are presented below the corresponding image components of the primary map to allow further visual inspection and comparison with those of the primary map.

6.1 Orthogonal projections [i](#)

6.1.1 Primary map

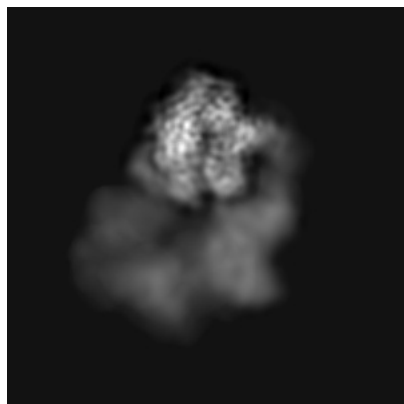

X

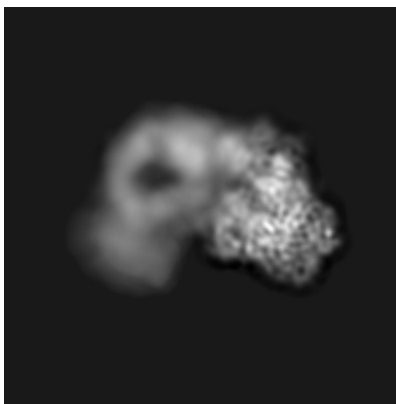

Y

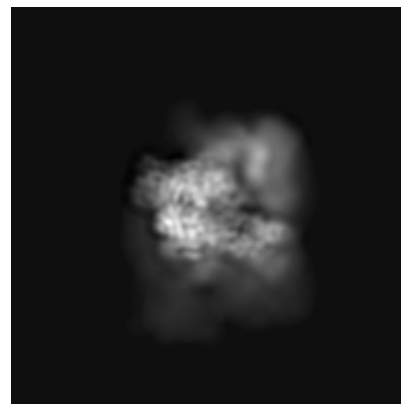

Z

6.1.2 Raw map

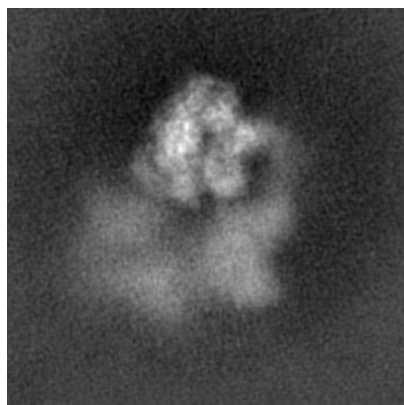

X

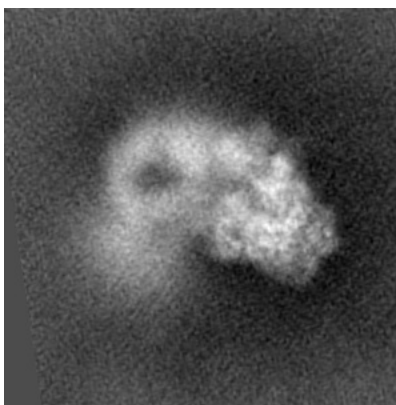

Y

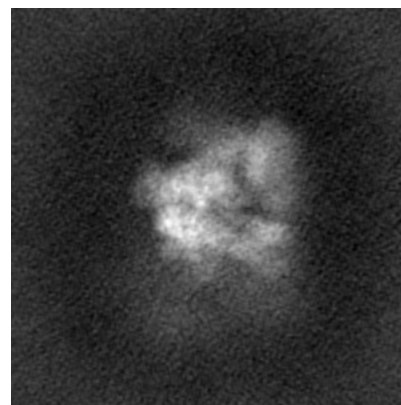

Z

The images above show the map projected in three orthogonal directions.

6.2 Central slices [i](#)

6.2.1 Primary map

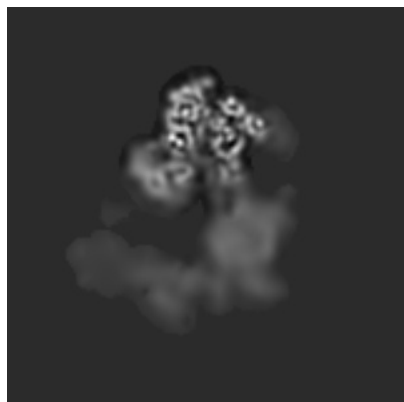

X Index: 160

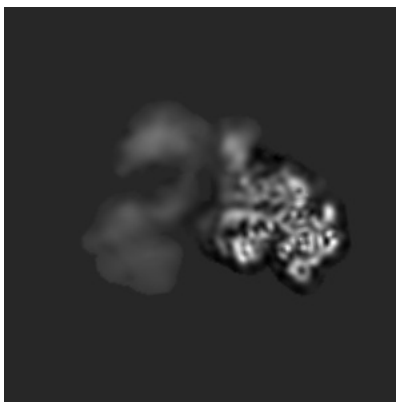

Y Index: 160



Z Index: 160

6.2.2 Raw map



X Index: 160

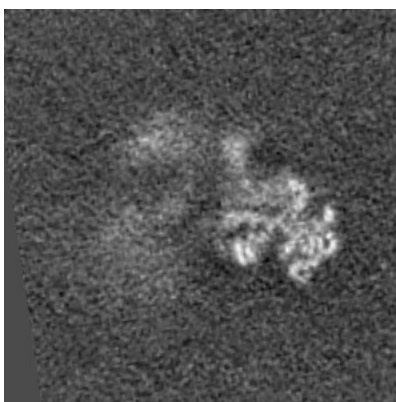

Y Index: 160

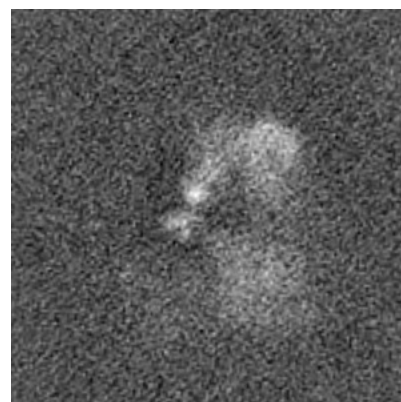

Z Index: 160

The images above show central slices of the map in three orthogonal directions.

6.3 Largest variance slices [i](#)

6.3.1 Primary map

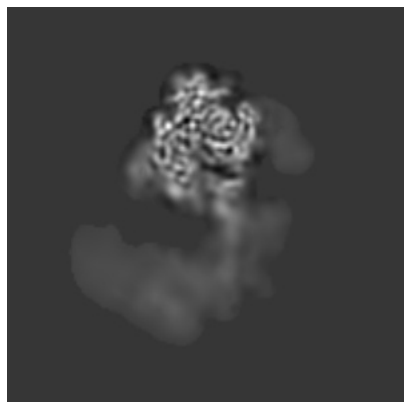

X Index: 146

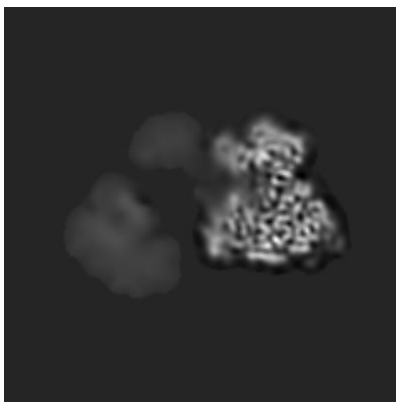

Y Index: 141



Z Index: 222

6.3.2 Raw map

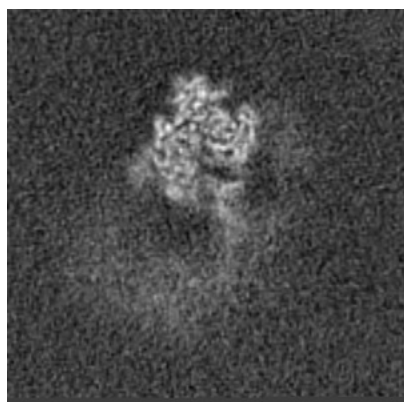

X Index: 146

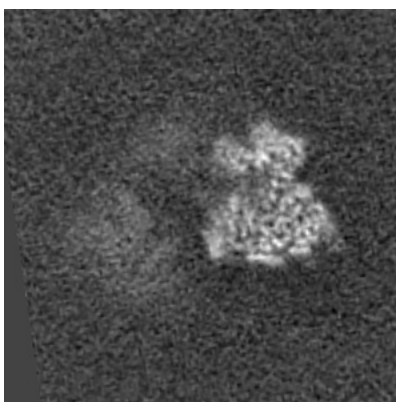

Y Index: 141

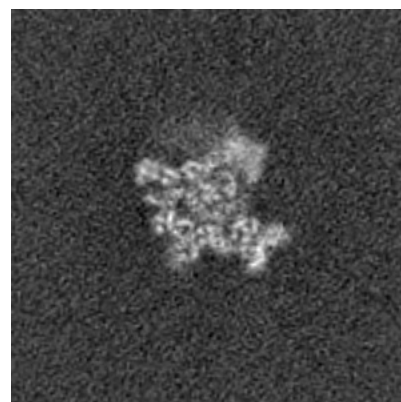

Z Index: 221

The images above show the largest variance slices of the map in three orthogonal directions.

6.4 Orthogonal standard-deviation projections (False-color) [i](#)

6.4.1 Primary map

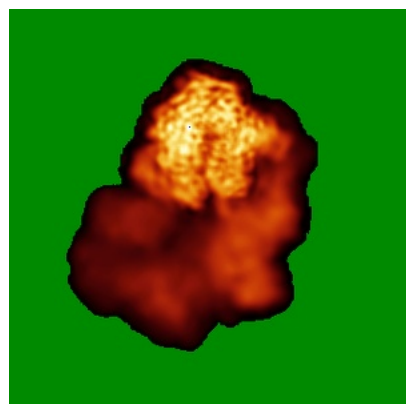

X

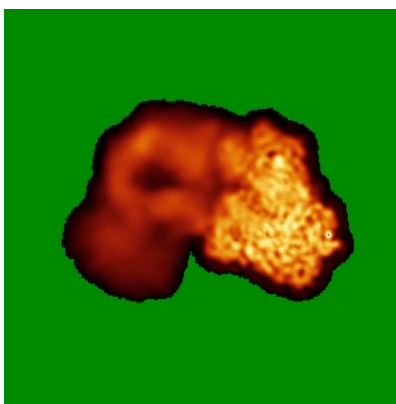

Y



Z

6.4.2 Raw map

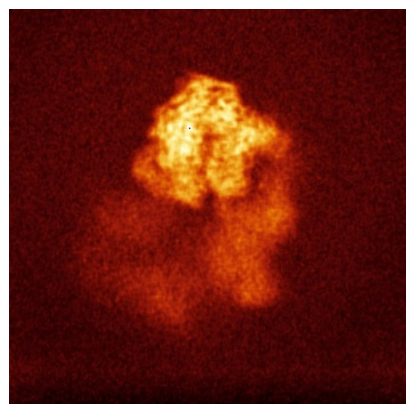

X

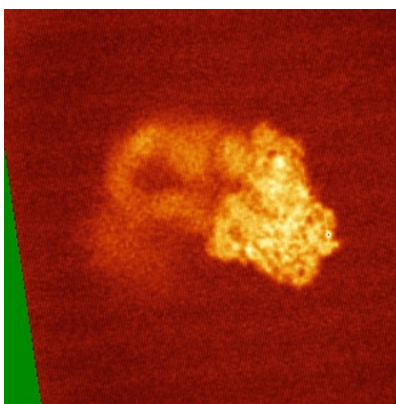

Y

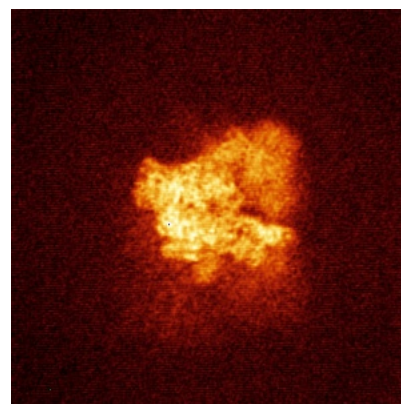

Z

The images above show the map standard deviation projections with false color in three orthogonal directions. Minimum values are shown in green, max in blue, and dark to light orange shades represent small to large values respectively.

6.5 Orthogonal surface views [i](#)

6.5.1 Primary map

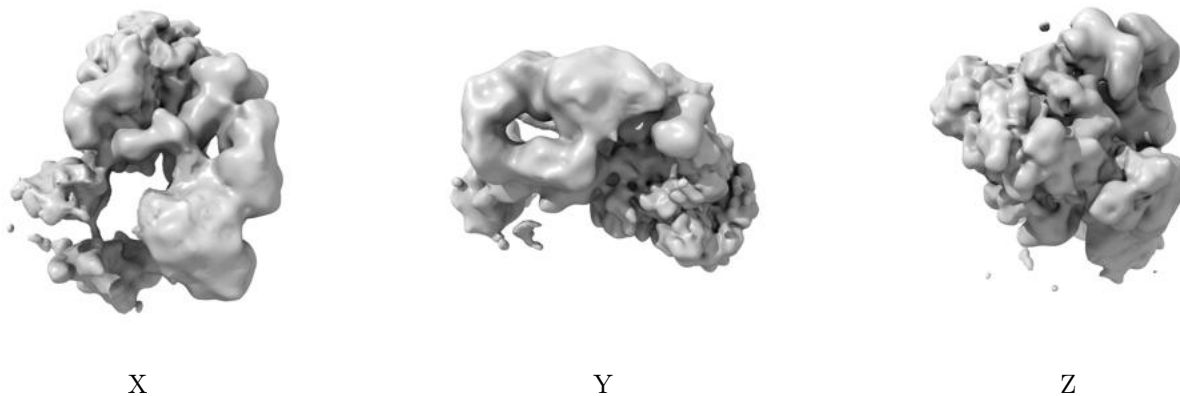

The images above show the 3D surface view of the map at the recommended contour level 0.474. These images, in conjunction with the slice images, may facilitate assessment of whether an appropriate contour level has been provided.

6.5.2 Raw map

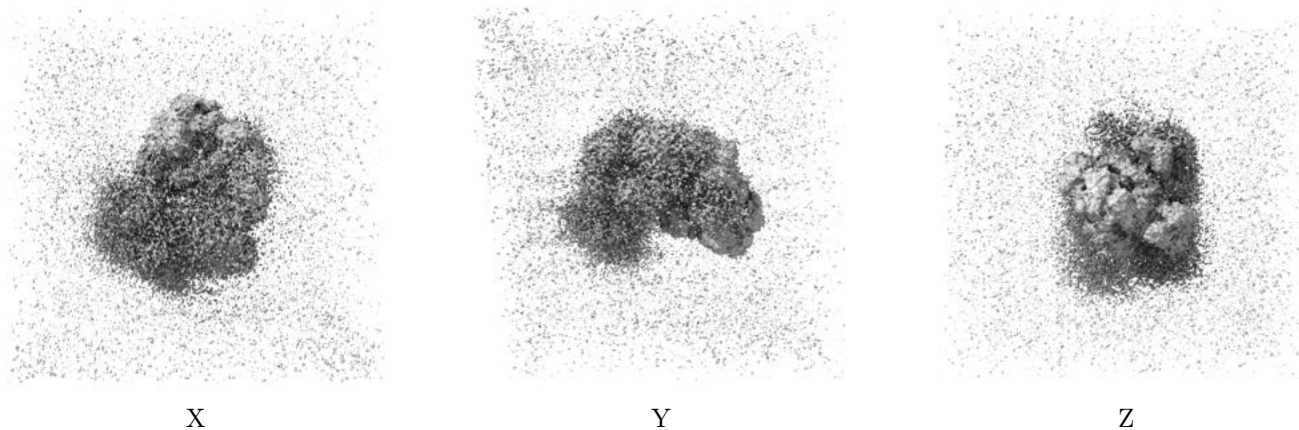

These images show the 3D surface of the raw map. The raw map's contour level was selected so that its surface encloses the same volume as the primary map does at its recommended contour level.

6.6 Mask visualisation [i](#)

This section was not generated. No masks/segmentation were deposited.

7 Map analysis [i](#)

This section contains the results of statistical analysis of the map.

7.1 Map-value distribution [i](#)

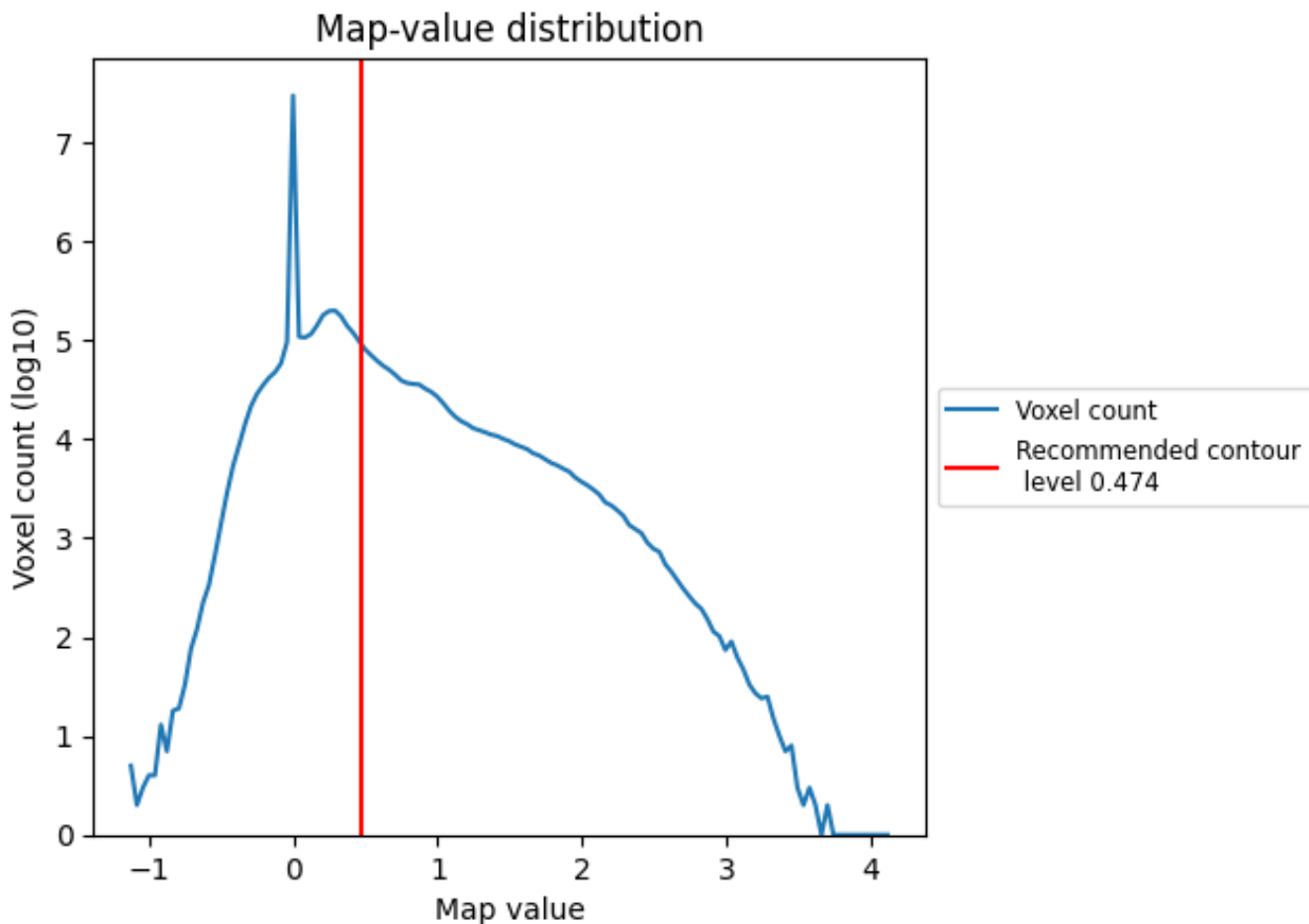

The map-value distribution is plotted in 128 intervals along the x-axis. The y-axis is logarithmic. A spike in this graph at zero usually indicates that the volume has been masked.

7.2 Volume estimate [\(i\)](#)

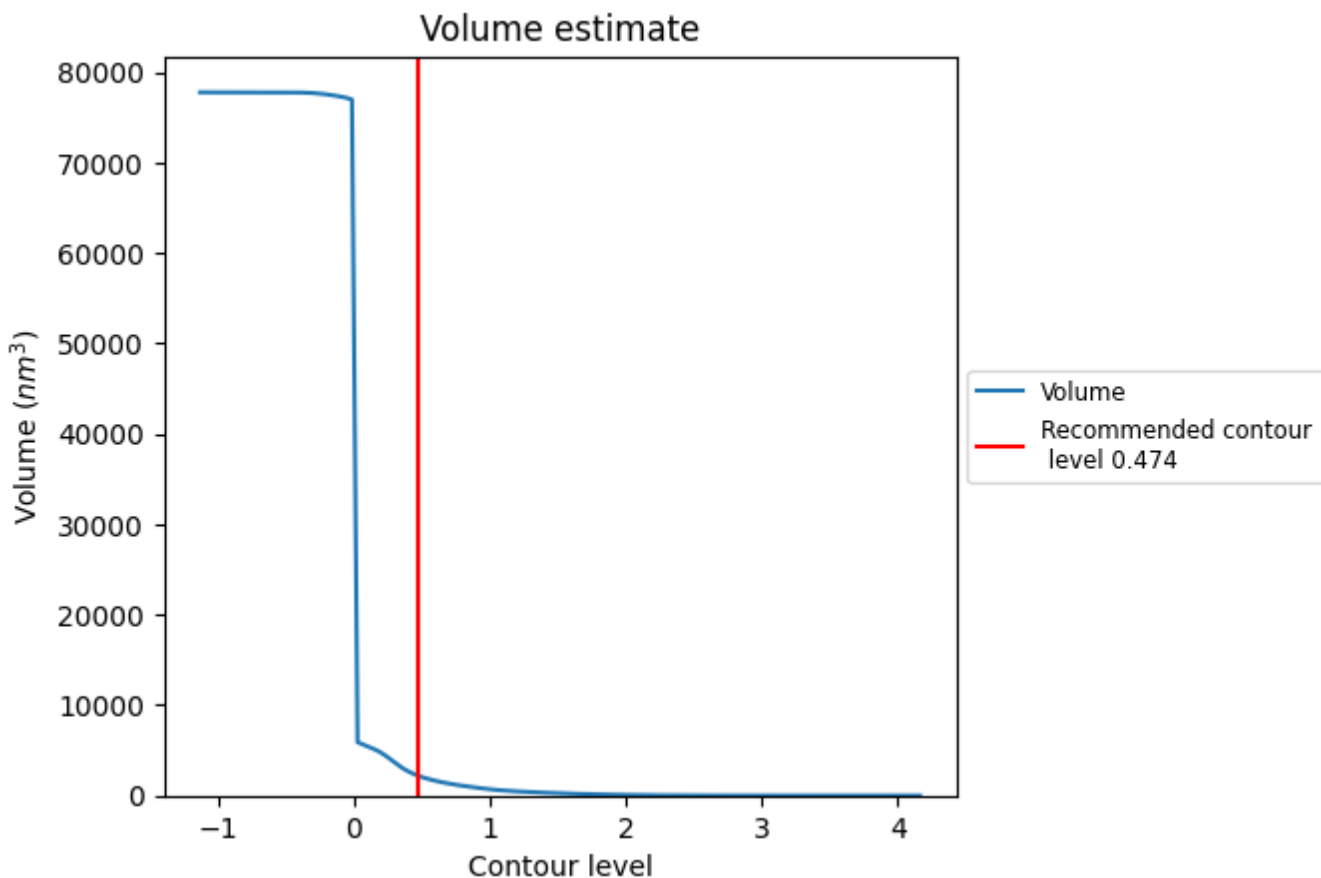

The volume at the recommended contour level is 2197 nm³; this corresponds to an approximate mass of 1984 kDa.

The volume estimate graph shows how the enclosed volume varies with the contour level. The recommended contour level is shown as a vertical line and the intersection between the line and the curve gives the volume of the enclosed surface at the given level.

7.3 Rotationally averaged power spectrum i

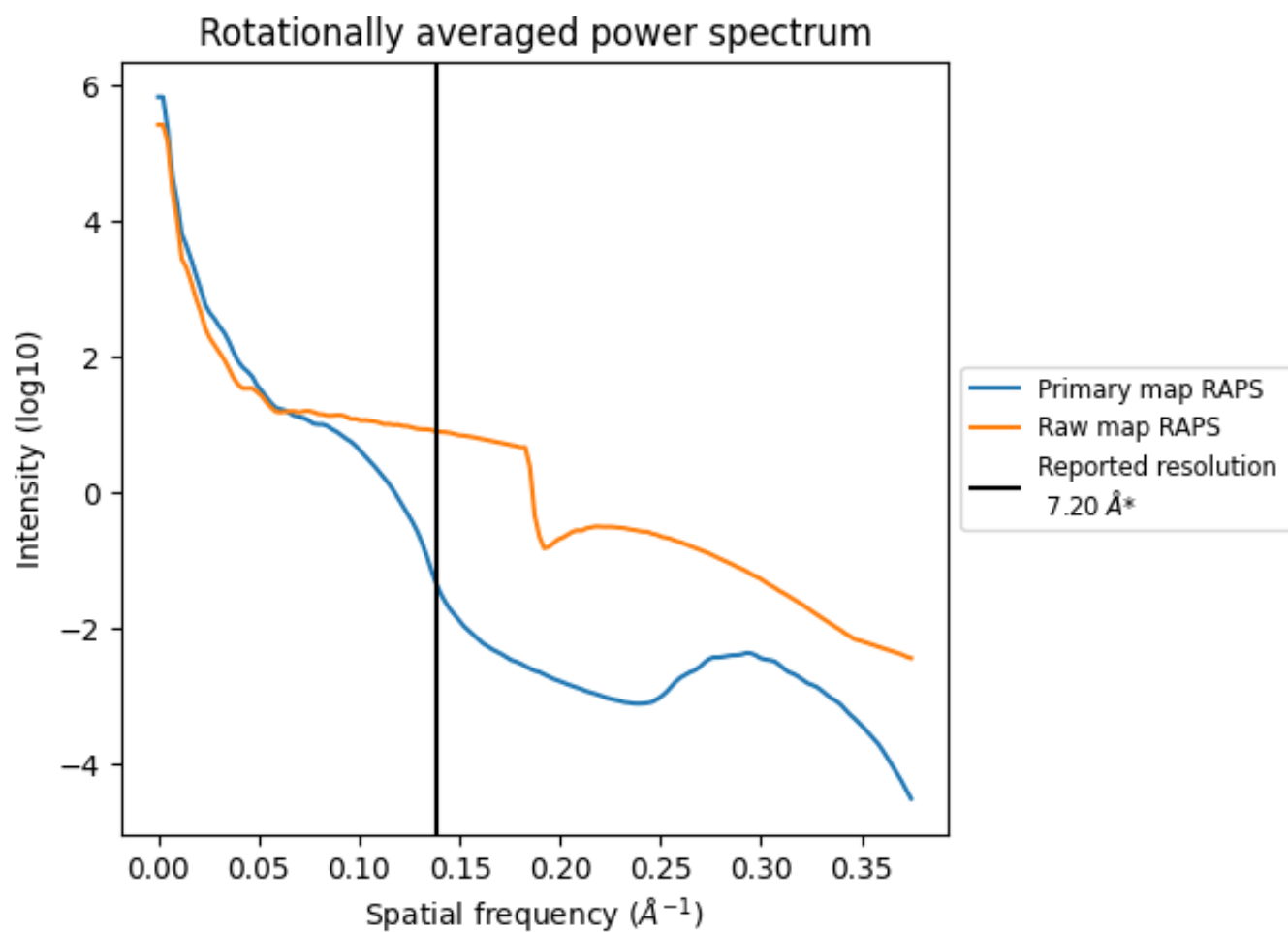

*Reported resolution corresponds to spatial frequency of 0.139 Å⁻¹

8 Fourier-Shell correlation [i](#)

Fourier-Shell Correlation (FSC) is the most commonly used method to estimate the resolution of single-particle and subtomogram-averaged maps. The shape of the curve depends on the imposed symmetry, mask and whether or not the two 3D reconstructions used were processed from a common reference. The reported resolution is shown as a black line. A curve is displayed for the half-bit criterion in addition to lines showing the 0.143 gold standard cut-off and 0.5 cut-off.

8.1 FSC [i](#)

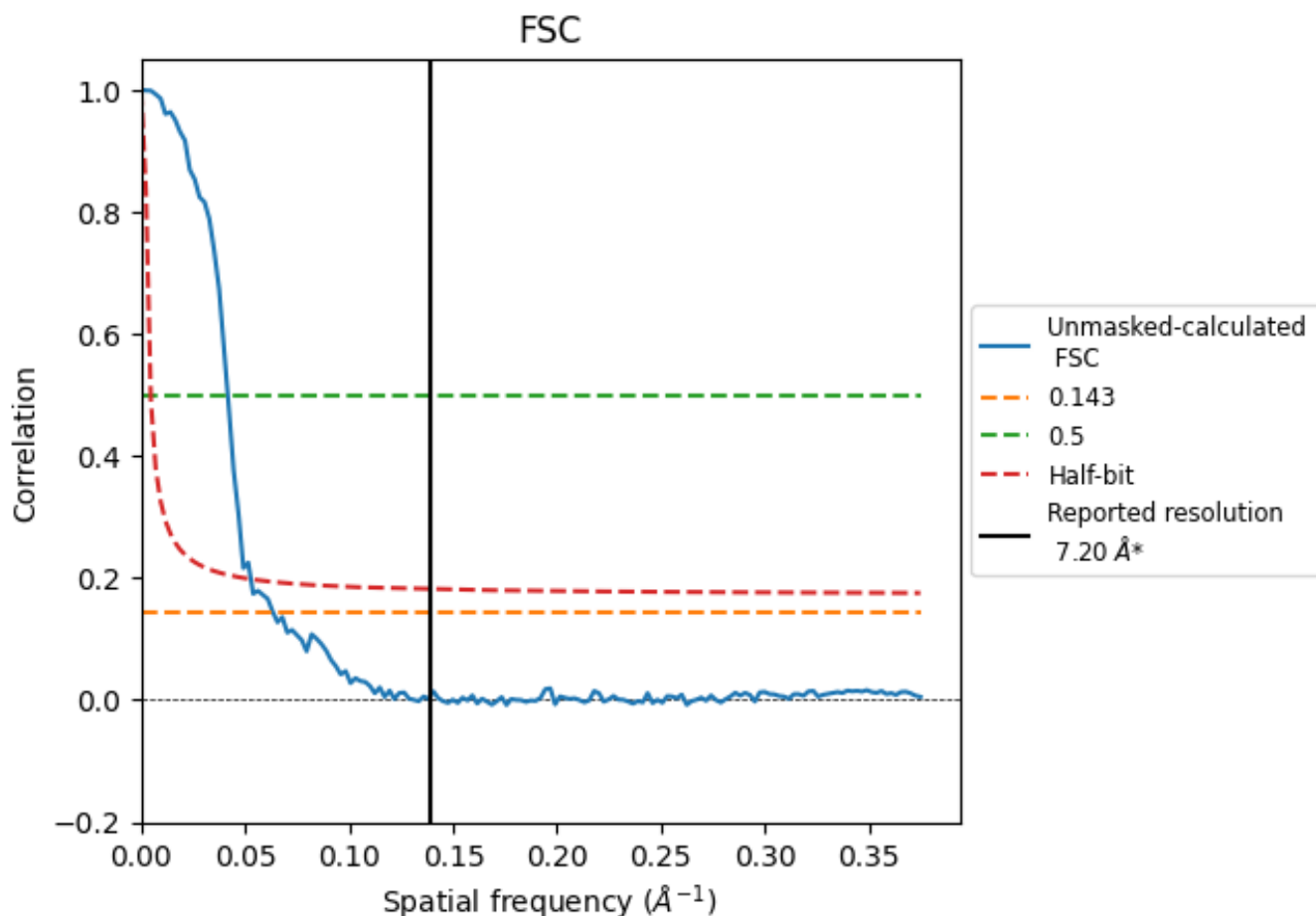

*Reported resolution corresponds to spatial frequency of 0.139 Å⁻¹

8.2 Resolution estimates [i](#)

Resolution estimate (Å)	Estimation criterion (FSC cut-off)		
	0.143	0.5	Half-bit
Reported by author	7.20	-	-
Author-provided FSC curve	-	-	-
Unmasked-calculated*	15.75	23.98	18.94

*Resolution estimate based on FSC curve calculated by comparison of deposited half-maps. The value from deposited half-maps intersecting FSC 0.143 CUT-OFF 15.75 differs from the reported value 7.2 by more than 10 %

9 Map-model fit [i](#)

This section contains information regarding the fit between EMDB map EMD-37402 and PDB model 8WAR. Per-residue inclusion information can be found in section 3 on page 14.

9.1 Map-model overlay [i](#)

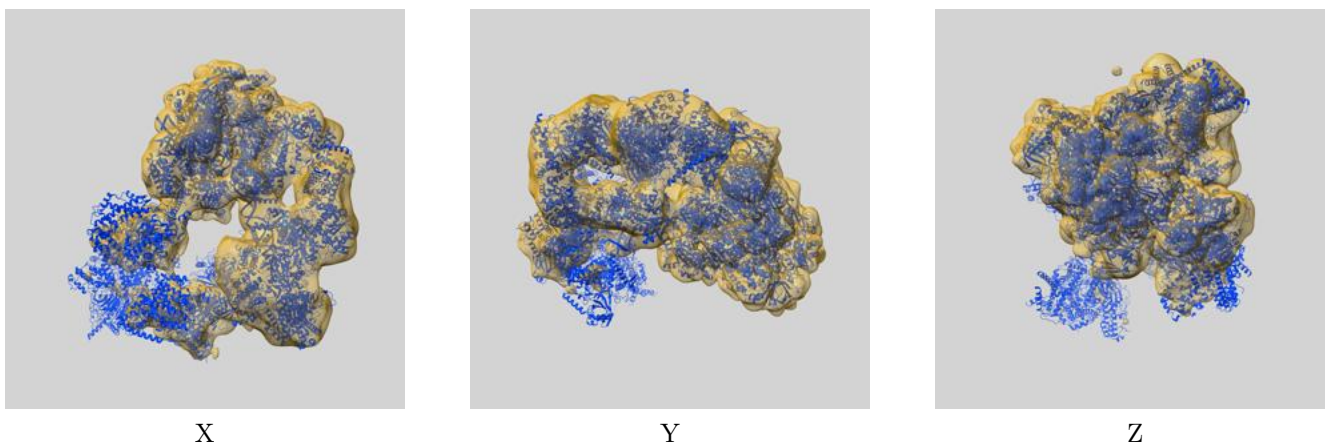

The images above show the 3D surface view of the map at the recommended contour level 0.474 at 50% transparency in yellow overlaid with a ribbon representation of the model coloured in blue. These images allow for the visual assessment of the quality of fit between the atomic model and the map.

9.2 Q-score mapped to coordinate model [i](#)

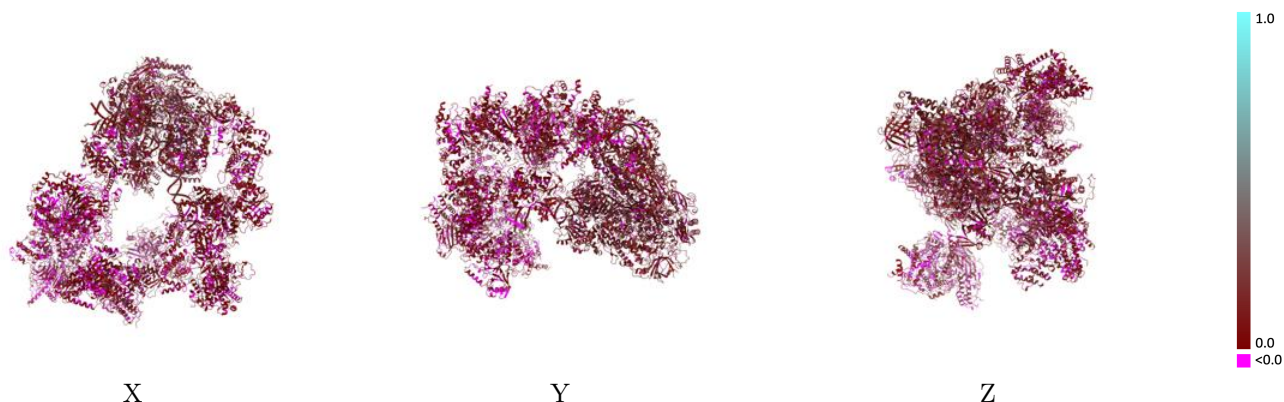

The images above show the model with each residue coloured according to its Q-score. This shows their resolvability in the map with higher Q-score values reflecting better resolvability. Please note: Q-score is calculating the resolvability of atoms, and thus high values are only expected at resolutions at which atoms can be resolved. Low Q-score values may therefore be expected for many entries.

9.3 Atom inclusion mapped to coordinate model [i](#)

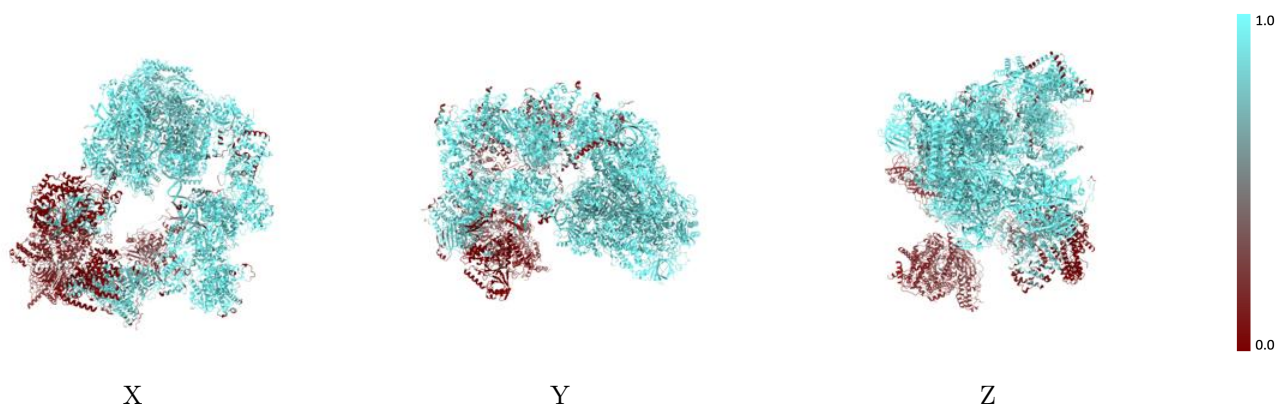

The images above show the model with each residue coloured according to its atom inclusion. This shows to what extent they are inside the map at the recommended contour level (0.474).



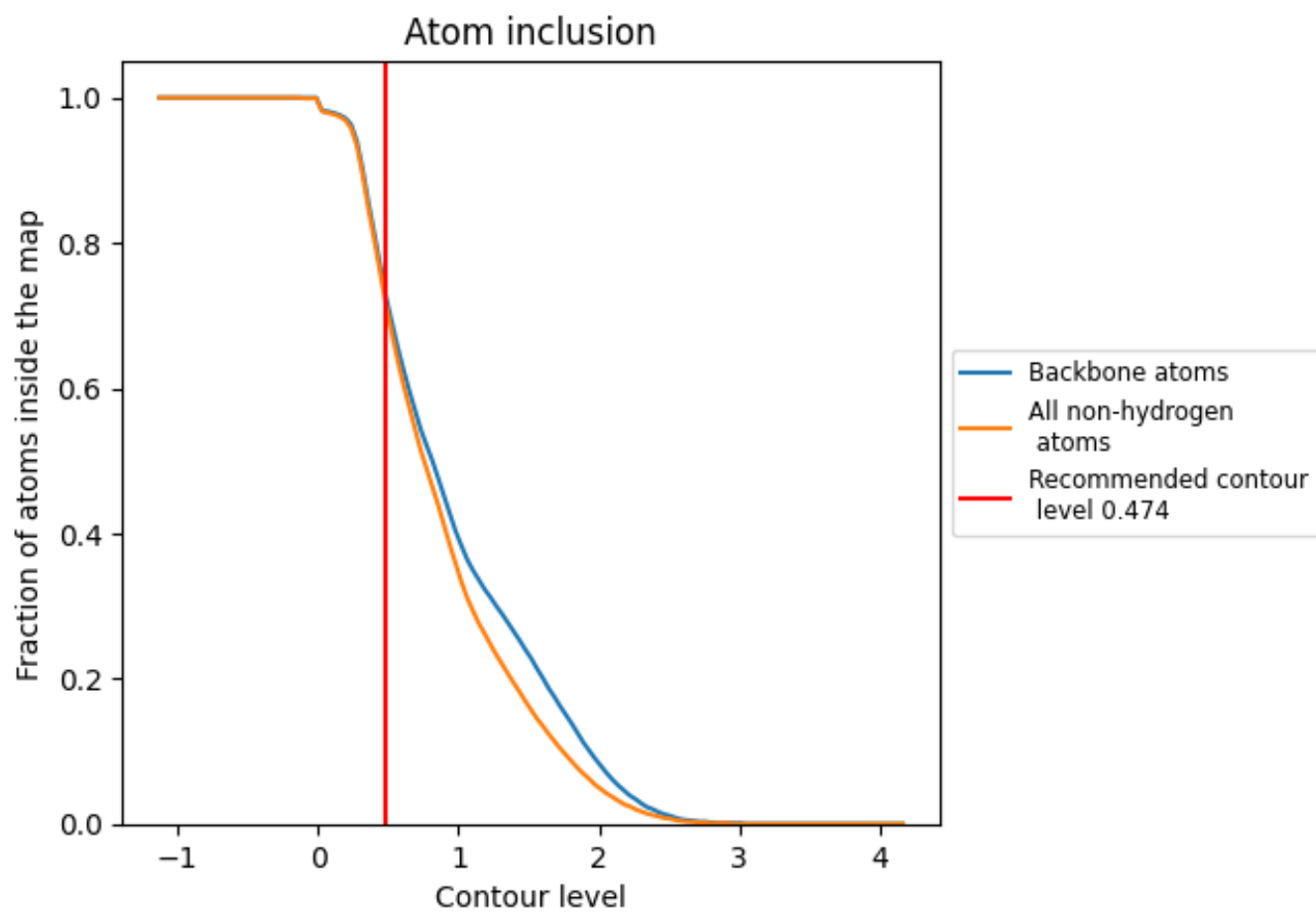



































































9.4 Atom inclusion [i](#)



At the recommended contour level, 74% of all backbone atoms, 72% of all non-hydrogen atoms, are inside the map.

9.5 Map-model fit summary

The table lists the average atom inclusion at the recommended contour level (0.474) and Q-score for the entire model and for each chain.

Chain	Atom inclusion	Q-score
All	 0.7250	 0.0760
0	 0.6720	 0.0520
1	 0.8740	 0.0570
2	 0.9440	 0.0670
3	 0.9410	 0.0410
4	 0.9190	 0.0640
5	 0.8420	 0.0720
6	 0.8960	 0.0540
7	 0.9450	 0.0620
A	 0.1380	 0.0370
B	 0.8240	 0.0450
D	 0.2870	 0.0300
E	 0.7660	 0.0480
F	 0.3330	 0.0400
G	 0.0040	 0.0160
H	 0.4470	 0.0320
I	 0.2680	 0.0240
J	 0.0550	 0.0240
L	 0.0000	 0.0210
N	 0.9520	 0.0960
O	 0.9420	 0.0710
P	 0.9970	 0.1110
Q	 0.9330	 0.0790
R	 0.9820	 0.1340
S	 0.9400	 0.0720
T	 0.9750	 0.1130
U	 0.9770	 0.0860
V	 0.9780	 0.0990
X	 0.9910	 0.1590
Y	 0.9200	 0.1310
Z	 0.9940	 0.1810
c	 0.0000	 0.0210
d	 0.0030	 0.0090
e	 0.0200	 0.0210
f	 0.3360	 0.0390



Continued on next page...

Continued from previous page...

Chain	Atom inclusion	Q-score
i	0.0030	0.0390
j	0.0000	0.0210
k	0.0000	-0.0140
l	0.0000	0.0430
m	0.0000	-0.0090
o	0.9620	0.1320
p	0.9550	0.1220
q	0.9770	0.1380
r	0.9840	0.1120
s	0.9770	0.1450
t	0.9780	0.1440
u	0.9910	0.1050
v	0.9780	0.1440
w	0.9770	0.1100
x	0.9660	0.1220
y	0.9800	0.1530
z	0.9890	0.1430