



wwPDB X-ray Structure Validation Summary Report ⓘ

Mar 6, 2026 – 08:38 PM UTC

PDB ID : 3WSB / pdb_00003wsb
Title : The Tuberculosis Drug SQ109 Inhibits Trypanosoma cruzi Cell Proliferation and acts Synergistically with Posaconazole
Authors : Shang, N.; Li, Q.; Huang, C.H.; Oldfield, E.; Guo, R.T.
Deposited on : 2014-03-05
Resolution : 2.40 Å (reported)

This is a wwPDB X-ray Structure Validation Summary Report for a publicly released PDB entry.

We welcome your comments at validation@mail.wwpdb.org

A user guide is available at

<https://www.wwpdb.org/validation/2017/XrayValidationReportHelp>

with specific help available everywhere you see the ⓘ symbol.

The types of validation reports are described at

<http://www.wwpdb.org/validation/2017/FAQs#types>.

The following versions of software and data (see [references ⓘ](#)) were used in the production of this report:

MolProbity : 4-5-2 with Phenix2.0
Mogul : 2022.3.0, CSD as543be (2022)
Xtriage (Phenix) : 2.0
EDS : 3.0
Buster-report : wwPDB partial adaption of 1.1.7 (2018)
Percentile statistics : 20250101.v01 (using entries in the PDB archive January 1st 2025)
CCP4 : 9.0.010 (Gargrove)
Density-Fitness : 1.0.12
Ideal geometry (proteins) : Engh & Huber (2001)
Ideal geometry (DNA, RNA) : Parkinson et al. (1996)
Validation Pipeline (wwPDB-VP) : 2.49

1 Overall quality at a glance

The following experimental techniques were used to determine the structure:

X-RAY DIFFRACTION

The reported resolution of this entry is 2.40 Å.

Percentile scores (ranging between 0-100) for global validation metrics of the entry are shown in the following graphic. The table shows the number of entries on which the scores are based.

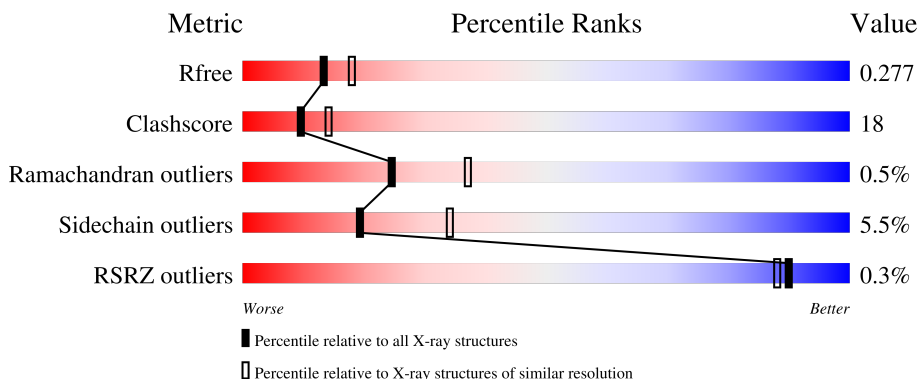

Metric	Whole archive (#Entries)	Similar resolution (#Entries, resolution range(Å))
R_{free}	180053	4912 (2.40-2.40)
Clashscore	190562	5391 (2.40-2.40)
Ramachandran outliers	187476	5320 (2.40-2.40)
Sidechain outliers	187428	5321 (2.40-2.40)
RSRZ outliers	180081	4916 (2.40-2.40)

The table below summarises the geometric issues observed across the polymeric chains and their fit to the electron density. The red, orange, yellow and green segments of the lower bar indicate the fraction of residues that contain outliers for ≥ 3 , 2, 1 and 0 types of geometric quality criteria respectively. A grey segment represents the fraction of residues that are not modelled. The numeric value for each fraction is indicated below the corresponding segment, with a dot representing fractions $\leq 5\%$. The upper red bar (where present) indicates the fraction of residues that have poor fit to the electron density. The numeric value is given above the bar.

Mol	Chain	Length	Quality of chain
1	A	365	62% 27% 7%
1	B	365	62% 28% 7%
1	C	365	61% 28% 7%
1	D	365	54% 36% 7%

2 Entry composition [i](#)

There are 4 unique types of molecules in this entry. The entry contains 11630 atoms, of which 0 are hydrogens and 0 are deuteriums.

In the tables below, the ZeroOcc column contains the number of atoms modelled with zero occupancy, the AltConf column contains the number of residues with at least one atom in alternate conformation and the Trace column contains the number of residues modelled with at most 2 atoms.

- Molecule 1 is a protein called Farnesyltransferase, putative.

Mol	Chain	Residues	Atoms					ZeroOcc	AltConf	Trace
			Total	C	N	O	S			
1	A	341	2751	1745	473	511	22	0	0	0
1	B	341	2751	1745	473	511	22	0	0	0
1	C	341	2751	1745	473	511	22	0	0	0
1	D	341	2752	1745	473	512	22	0	0	0

There are 88 discrepancies between the modelled and reference sequences:

Chain	Residue	Modelled	Actual	Comment	Reference
A	4	MET	-	expression tag	UNP Q4CWB4
A	5	GLY	-	expression tag	UNP Q4CWB4
A	6	SER	-	expression tag	UNP Q4CWB4
A	7	SER	-	expression tag	UNP Q4CWB4
A	8	HIS	-	expression tag	UNP Q4CWB4
A	9	HIS	-	expression tag	UNP Q4CWB4
A	10	HIS	-	expression tag	UNP Q4CWB4
A	11	HIS	-	expression tag	UNP Q4CWB4
A	12	HIS	-	expression tag	UNP Q4CWB4
A	13	HIS	-	expression tag	UNP Q4CWB4
A	14	SER	-	expression tag	UNP Q4CWB4
A	15	SER	-	expression tag	UNP Q4CWB4
A	16	GLY	-	expression tag	UNP Q4CWB4
A	17	LEU	-	expression tag	UNP Q4CWB4
A	18	VAL	-	expression tag	UNP Q4CWB4
A	19	PRO	-	expression tag	UNP Q4CWB4
A	20	ARG	-	expression tag	UNP Q4CWB4
A	21	GLY	-	expression tag	UNP Q4CWB4
A	22	SER	-	expression tag	UNP Q4CWB4
A	23	HIS	-	expression tag	UNP Q4CWB4
A	24	MET	-	expression tag	UNP Q4CWB4

Continued on next page...

Continued from previous page...

Chain	Residue	Modelled	Actual	Comment	Reference
A	82	GLU	ASP	engineered mutation	UNP Q4CWB4
B	4	MET	-	expression tag	UNP Q4CWB4
B	5	GLY	-	expression tag	UNP Q4CWB4
B	6	SER	-	expression tag	UNP Q4CWB4
B	7	SER	-	expression tag	UNP Q4CWB4
B	8	HIS	-	expression tag	UNP Q4CWB4
B	9	HIS	-	expression tag	UNP Q4CWB4
B	10	HIS	-	expression tag	UNP Q4CWB4
B	11	HIS	-	expression tag	UNP Q4CWB4
B	12	HIS	-	expression tag	UNP Q4CWB4
B	13	HIS	-	expression tag	UNP Q4CWB4
B	14	SER	-	expression tag	UNP Q4CWB4
B	15	SER	-	expression tag	UNP Q4CWB4
B	16	GLY	-	expression tag	UNP Q4CWB4
B	17	LEU	-	expression tag	UNP Q4CWB4
B	18	VAL	-	expression tag	UNP Q4CWB4
B	19	PRO	-	expression tag	UNP Q4CWB4
B	20	ARG	-	expression tag	UNP Q4CWB4
B	21	GLY	-	expression tag	UNP Q4CWB4
B	22	SER	-	expression tag	UNP Q4CWB4
B	23	HIS	-	expression tag	UNP Q4CWB4
B	24	MET	-	expression tag	UNP Q4CWB4
B	82	GLU	ASP	engineered mutation	UNP Q4CWB4
C	4	MET	-	expression tag	UNP Q4CWB4
C	5	GLY	-	expression tag	UNP Q4CWB4
C	6	SER	-	expression tag	UNP Q4CWB4
C	7	SER	-	expression tag	UNP Q4CWB4
C	8	HIS	-	expression tag	UNP Q4CWB4
C	9	HIS	-	expression tag	UNP Q4CWB4
C	10	HIS	-	expression tag	UNP Q4CWB4
C	11	HIS	-	expression tag	UNP Q4CWB4
C	12	HIS	-	expression tag	UNP Q4CWB4
C	13	HIS	-	expression tag	UNP Q4CWB4
C	14	SER	-	expression tag	UNP Q4CWB4
C	15	SER	-	expression tag	UNP Q4CWB4
C	16	GLY	-	expression tag	UNP Q4CWB4
C	17	LEU	-	expression tag	UNP Q4CWB4
C	18	VAL	-	expression tag	UNP Q4CWB4
C	19	PRO	-	expression tag	UNP Q4CWB4
C	20	ARG	-	expression tag	UNP Q4CWB4
C	21	GLY	-	expression tag	UNP Q4CWB4
C	22	SER	-	expression tag	UNP Q4CWB4

Continued on next page...

Continued from previous page...

Chain	Residue	Modelled	Actual	Comment	Reference
C	23	HIS	-	expression tag	UNP Q4CWB4
C	24	MET	-	expression tag	UNP Q4CWB4
C	82	GLU	ASP	engineered mutation	UNP Q4CWB4
D	4	MET	-	expression tag	UNP Q4CWB4
D	5	GLY	-	expression tag	UNP Q4CWB4
D	6	SER	-	expression tag	UNP Q4CWB4
D	7	SER	-	expression tag	UNP Q4CWB4
D	8	HIS	-	expression tag	UNP Q4CWB4
D	9	HIS	-	expression tag	UNP Q4CWB4
D	10	HIS	-	expression tag	UNP Q4CWB4
D	11	HIS	-	expression tag	UNP Q4CWB4
D	12	HIS	-	expression tag	UNP Q4CWB4
D	13	HIS	-	expression tag	UNP Q4CWB4
D	14	SER	-	expression tag	UNP Q4CWB4
D	15	SER	-	expression tag	UNP Q4CWB4
D	16	GLY	-	expression tag	UNP Q4CWB4
D	17	LEU	-	expression tag	UNP Q4CWB4
D	18	VAL	-	expression tag	UNP Q4CWB4
D	19	PRO	-	expression tag	UNP Q4CWB4
D	20	ARG	-	expression tag	UNP Q4CWB4
D	21	GLY	-	expression tag	UNP Q4CWB4
D	22	SER	-	expression tag	UNP Q4CWB4
D	23	HIS	-	expression tag	UNP Q4CWB4
D	24	MET	-	expression tag	UNP Q4CWB4
D	82	GLU	ASP	engineered mutation	UNP Q4CWB4

- Molecule 2 is S-[(2E,6E)-3,7,11-TRIMETHYLDODECA-2,6,10-TRIENYL] TRIHYDROGEN THIODIPHOSPHATE (CCD ID: FPS) (formula: C₁₅H₂₈O₆P₂S).

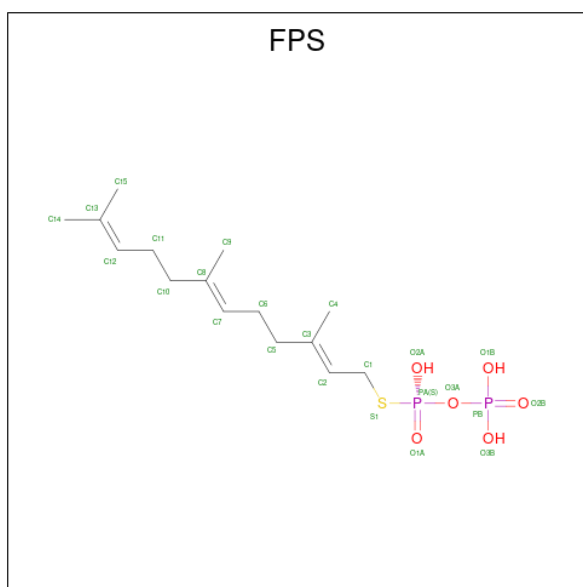

Mol	Chain	Residues	Atoms				ZeroOcc	AltConf	
			Total	C	O	P			S
2	A	1	24	15	6	2	1	0	0
2	B	1	24	15	6	2	1	0	0
2	C	1	24	15	6	2	1	0	0
2	D	1	24	15	6	2	1	0	0

- Molecule 3 is N-[(2Z)-3,7-dimethylocta-2,6-dien-1-yl]-N'-[(1R,3S,5R,7R)-tricyclo[3.3.1.1 3,7]dec-2-yl]ethane-1,2-diamine (CCD ID: RWZ) (formula: C₂₂H₃₈N₂).

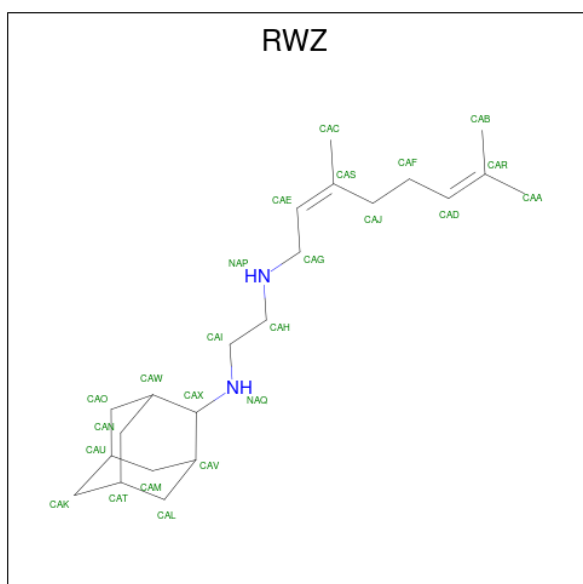

Mol	Chain	Residues	Atoms			ZeroOcc	AltConf
3	A	1	Total	C	N	0	0
			24	22	2		
3	B	1	Total	C	N	0	0
			24	22	2		
3	C	1	Total	C	N	0	0
			24	22	2		
3	D	1	Total	C	N	0	0
			24	22	2		

- Molecule 4 is water.

Mol	Chain	Residues	Atoms		ZeroOcc	AltConf
4	A	134	Total	O	0	0
			134	134		
4	B	132	Total	O	0	0
			132	132		
4	C	99	Total	O	0	0
			99	99		
4	D	68	Total	O	0	0
			68	68		

3 Residue-property plots

These plots are drawn for all protein, RNA, DNA and oligosaccharide chains in the entry. The first graphic for a chain summarises the proportions of the various outlier classes displayed in the second graphic. The second graphic shows the sequence view annotated by issues in geometry and electron density. Residues are color-coded according to the number of geometric quality criteria for which they contain at least one outlier: green = 0, yellow = 1, orange = 2 and red = 3 or more. A red dot above a residue indicates a poor fit to the electron density ($RSRZ > 2$). Stretches of 2 or more consecutive residues without any outlier are shown as a green connector. Residues present in the sample, but not in the model, are shown in grey.

- Molecule 1: Farnesyltransferase, putative

Chain A: 

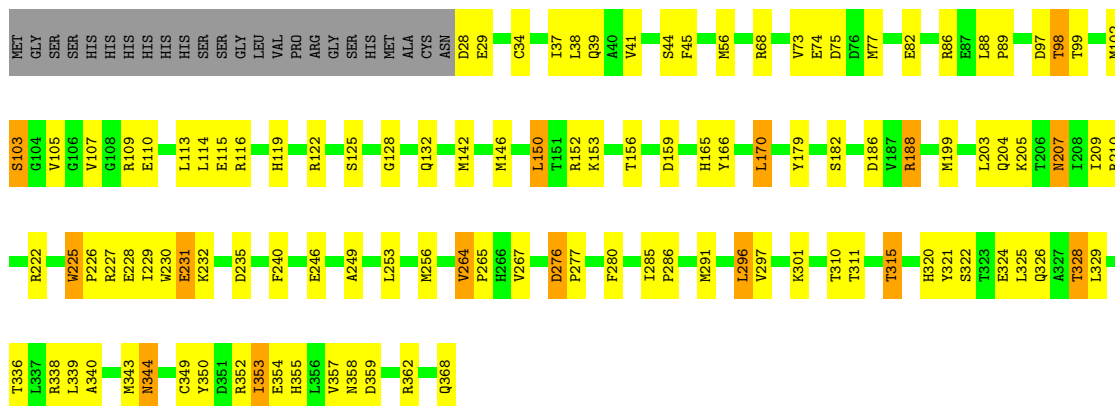

- Molecule 1: Farnesyltransferase, putative

Chain B: 

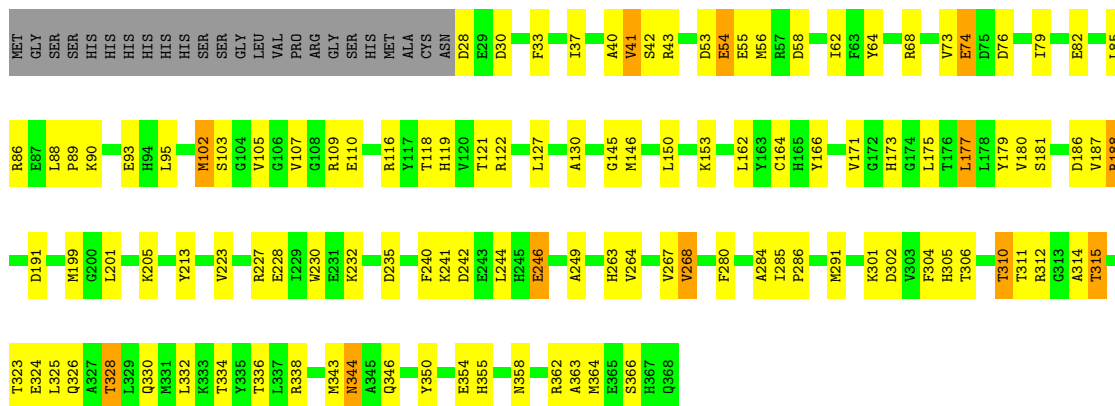

- Molecule 1: Farnesyltransferase, putative

Chain C: 

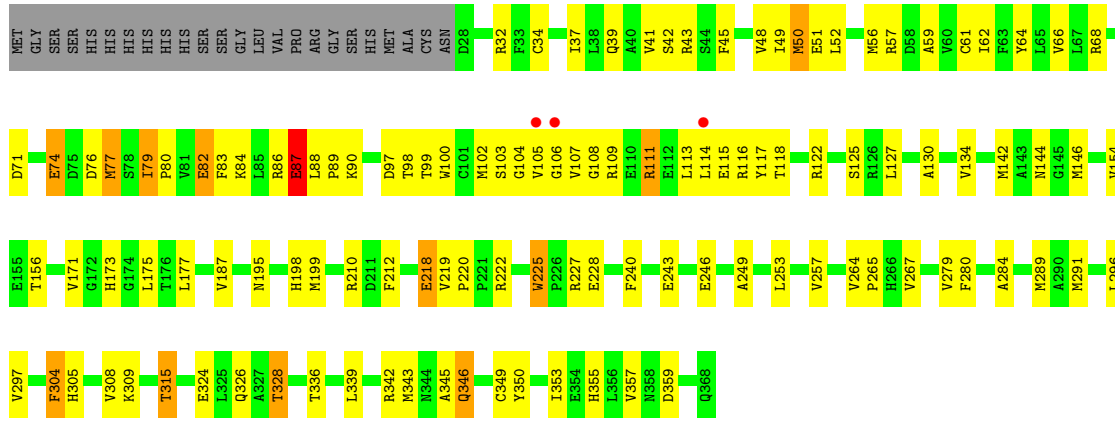

• Molecule 1: Farnesyltransferase, putative

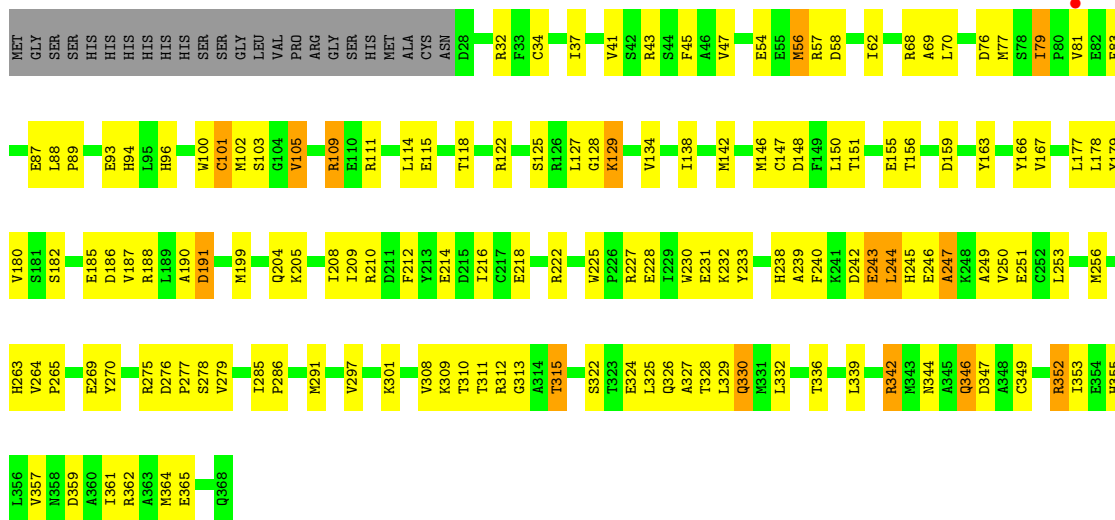

4 Data and refinement statistics

Property	Value	Source
Space group	P 21 21 21	Depositor
Cell constants a, b, c, α , β , γ	79.36Å 130.57Å 144.63Å 90.00° 90.00° 90.00°	Depositor
Resolution (Å)	24.90 – 2.40 24.90 – 2.40	Depositor EDS
% Data completeness (in resolution range)	(Not available) (24.90-2.40) 91.6 (24.90-2.40)	Depositor EDS
R_{merge}	0.06	Depositor
R_{sym}	(Not available)	Depositor
$\langle I/\sigma(I) \rangle$ ¹	2.26 (at 2.39Å)	Xtrriage
Refinement program	CNS 1.1	Depositor
R, R_{free}	0.216 , 0.277 0.215 , 0.277	Depositor DCC
R_{free} test set	2761 reflections (5.06%)	wwPDB-VP
Wilson B-factor (Å ²)	44.0	Xtrriage
Anisotropy	0.295	Xtrriage
Bulk solvent k_{sol} (e/Å ³), B_{sol} (Å ²)	0.33 , 43.5	EDS
L-test for twinning ²	$\langle L \rangle = 0.50$, $\langle L^2 \rangle = 0.33$	Xtrriage
Estimated twinning fraction	No twinning to report.	Xtrriage
F_o, F_c correlation	0.95	EDS
Total number of atoms	11630	wwPDB-VP
Average B, all atoms (Å ²)	52.0	wwPDB-VP

Xtrriage's analysis on translational NCS is as follows: *The largest off-origin peak in the Patterson function is 4.60% of the height of the origin peak. No significant pseudotranslation is detected.*

¹Intensities estimated from amplitudes.

²Theoretical values of $\langle |L| \rangle$, $\langle L^2 \rangle$ for acentric reflections are 0.5, 0.333 respectively for untwinned datasets, and 0.375, 0.2 for perfectly twinned datasets.

5 Model quality [i](#)

5.1 Standard geometry [i](#)

Bond lengths and bond angles in the following residue types are not validated in this section: FPS, RWZ

The Z score for a bond length (or angle) is the number of standard deviations the observed value is removed from the expected value. A bond length (or angle) with $|Z| > 5$ is considered an outlier worth inspection. RMSZ is the root-mean-square of all Z scores of the bond lengths (or angles).

Mol	Chain	Bond lengths		Bond angles	
		RMSZ	# Z >5	RMSZ	# Z >5
1	A	0.49	1/2809 (0.0%)	0.94	12/3806 (0.3%)
1	B	0.46	0/2809	0.93	9/3806 (0.2%)
1	C	0.42	0/2809	0.90	7/3806 (0.2%)
1	D	0.41	0/2810	0.89	7/3806 (0.2%)
All	All	0.44	1/11237 (0.0%)	0.92	35/15224 (0.2%)

All (1) bond length outliers are listed below:

Mol	Chain	Res	Type	Atoms	Z	Observed(Å)	Ideal(Å)
1	A	264	VAL	CA-CB	5.10	1.56	1.54

The worst 5 of 35 bond angle outliers are listed below:

Mol	Chain	Res	Type	Atoms	Z	Observed(°)	Ideal(°)
1	A	29	GLU	N-CA-C	-9.49	101.47	113.23
1	D	244	LEU	N-CA-C	-8.01	102.60	112.38
1	A	103	SER	N-CA-C	7.85	123.03	113.38
1	A	150	LEU	N-CA-C	-7.75	103.96	113.41
1	B	41	VAL	N-CA-C	7.44	119.47	111.58

There are no chirality outliers.

There are no planarity outliers.

5.2 Too-close contacts [i](#)

In the following table, the Non-H and H(model) columns list the number of non-hydrogen atoms and hydrogen atoms in the chain respectively. The H(added) column lists the number of hydrogen atoms added and optimized by MolProbity. The Clashes column lists the number of clashes within the asymmetric unit, whereas Symm-Clashes lists symmetry-related clashes.

Mol	Chain	Non-H	H(model)	H(added)	Clashes	Symm-Clashes
1	A	2751	0	2698	87	0
1	B	2751	0	2698	87	0
1	C	2751	0	2698	99	0
1	D	2752	0	2698	119	0
2	A	24	0	25	1	0
2	B	24	0	25	4	0
2	C	24	0	25	3	0
2	D	24	0	25	4	0
3	A	24	0	38	3	0
3	B	24	0	38	4	0
3	C	24	0	38	2	0
3	D	24	0	38	4	0
4	A	134	0	0	0	1
4	B	132	0	0	4	0
4	C	99	0	0	0	1
4	D	68	0	0	3	0
All	All	11630	0	11044	396	1

The all-atom clashscore is defined as the number of clashes found per 1000 atoms (including hydrogen atoms). The all-atom clashscore for this structure is 18.

The worst 5 of 396 close contacts within the same asymmetric unit are listed below, sorted by their clash magnitude.

Atom-1	Atom-2	Interatomic distance (Å)	Clash overlap (Å)
1:C:343:MET:HE2	1:C:350:TYR:HA	1.28	1.16
1:C:343:MET:HE1	1:C:353:ILE:HB	1.39	1.05
1:D:62:ILE:HG13	1:D:127:LEU:HD11	1.46	0.96
1:C:83:PHE:HE2	1:C:87:GLU:HG3	1.35	0.90
1:B:118:THR:HG22	1:B:122:ARG:HH21	1.38	0.88

All (1) symmetry-related close contacts are listed below. The label for Atom-2 includes the symmetry operator and encoded unit-cell translations to be applied.

Atom-1	Atom-2	Interatomic distance (Å)	Clash overlap (Å)
4:A:722:HOH:O	4:C:596:HOH:O[3_544]	2.10	0.10

5.3 Torsion angles [i](#)

5.3.1 Protein backbone [i](#)

In the following table, the Percentiles column shows the percent Ramachandran outliers of the chain as a percentile score with respect to all X-ray entries followed by that with respect to entries of similar resolution.

The Analysed column shows the number of residues for which the backbone conformation was analysed, and the total number of residues.

Mol	Chain	Analysed	Favoured	Allowed	Outliers	Percentiles	
1	A	339/365 (93%)	324 (96%)	15 (4%)	0	100	100
1	B	339/365 (93%)	318 (94%)	21 (6%)	0	100	100
1	C	339/365 (93%)	314 (93%)	22 (6%)	3 (1%)	14	22
1	D	339/365 (93%)	307 (91%)	28 (8%)	4 (1%)	10	16
All	All	1356/1460 (93%)	1263 (93%)	86 (6%)	7 (0%)	24	37

5 of 7 Ramachandran outliers are listed below:

Mol	Chain	Res	Type
1	D	349	CYS
1	C	305	HIS
1	D	191	ASP
1	D	101	CYS
1	D	247	ALA

5.3.2 Protein sidechains [i](#)

In the following table, the Percentiles column shows the percent sidechain outliers of the chain as a percentile score with respect to all X-ray entries followed by that with respect to entries of similar resolution.

The Analysed column shows the number of residues for which the sidechain conformation was analysed, and the total number of residues.

Mol	Chain	Analysed	Rotameric	Outliers	Percentiles	
1	A	298/318 (94%)	283 (95%)	15 (5%)	22	38
1	B	298/318 (94%)	283 (95%)	15 (5%)	22	38
1	C	298/318 (94%)	280 (94%)	18 (6%)	17	31
1	D	298/318 (94%)	280 (94%)	18 (6%)	17	31
All	All	1192/1272 (94%)	1126 (94%)	66 (6%)	19	34

5 of 66 residues with a non-rotameric sidechain are listed below:

Mol	Chain	Res	Type
1	D	232	LYS
1	D	315	THR
1	D	362	ARG
1	B	246	GLU
1	B	235	ASP

Sometimes sidechains can be flipped to improve hydrogen bonding and reduce clashes. 5 of 34 such sidechains are listed below:

Mol	Chain	Res	Type
1	D	204	GLN
1	D	266	HIS
1	D	346	GLN
1	B	119	HIS
1	A	368	GLN

5.3.3 RNA [i](#)

There are no RNA molecules in this entry.

5.4 Non-standard residues in protein, DNA, RNA chains [i](#)

There are no non-standard protein/DNA/RNA residues in this entry.

5.5 Carbohydrates [i](#)

There are no oligosaccharides in this entry.

5.6 Ligand geometry [i](#)

8 ligands are modelled in this entry.

In the following table, the Counts columns list the number of bonds (or angles) for which Mogul statistics could be retrieved, the number of bonds (or angles) that are observed in the model and the number of bonds (or angles) that are defined in the Chemical Component Dictionary. The Link column lists molecule types, if any, to which the group is linked. The Z score for a bond length (or angle) is the number of standard deviations the observed value is removed from the expected value. A bond length (or angle) with $|Z| > 2$ is considered an outlier worth inspection. RMSZ is the root-mean-square of all Z scores of the bond lengths (or angles).

Mol	Type	Chain	Res	Link	Bond lengths			Bond angles		
					Counts	RMSZ	# Z > 2	Counts	RMSZ	# Z > 2
3	RWZ	C	402	-	25,26,26	1.85	3 (12%)	31,35,35	1.48	4 (12%)
3	RWZ	B	402	-	25,26,26	1.85	2 (8%)	31,35,35	1.51	4 (12%)
2	FPS	D	401	-	20,23,23	1.33	2 (10%)	24,31,31	1.56	6 (25%)
3	RWZ	A	502	-	25,26,26	1.89	2 (8%)	31,35,35	1.47	5 (16%)
2	FPS	A	501	-	20,23,23	1.33	2 (10%)	24,31,31	1.56	6 (25%)
2	FPS	B	401	-	20,23,23	1.29	2 (10%)	24,31,31	1.54	5 (20%)
3	RWZ	D	402	-	25,26,26	1.87	3 (12%)	31,35,35	1.49	4 (12%)
2	FPS	C	401	-	20,23,23	1.33	2 (10%)	24,31,31	1.48	5 (20%)

In the following table, the Chirals column lists the number of chiral outliers, the number of chiral centers analysed, the number of these observed in the model and the number defined in the Chemical Component Dictionary. Similar counts are reported in the Torsion and Rings columns. '-' means no outliers of that kind were identified.

Mol	Type	Chain	Res	Link	Chirals	Torsions	Rings
3	RWZ	C	402	-	-	6/15/43/43	0/4/3/3
3	RWZ	B	402	-	-	8/15/43/43	0/4/3/3
2	FPS	D	401	-	-	6/19/25/25	-
3	RWZ	A	502	-	-	8/15/43/43	0/4/3/3
2	FPS	A	501	-	-	6/19/25/25	-
2	FPS	B	401	-	-	7/19/25/25	-
3	RWZ	D	402	-	-	8/15/43/43	0/4/3/3
2	FPS	C	401	-	-	7/19/25/25	-

The worst 5 of 18 bond length outliers are listed below:

Mol	Chain	Res	Type	Atoms	Z	Observed(Å)	Ideal(Å)
3	A	502	RWZ	CAX-NAQ	-8.05	1.33	1.47
3	B	402	RWZ	CAX-NAQ	-7.92	1.34	1.47
3	D	402	RWZ	CAX-NAQ	-7.83	1.34	1.47
3	C	402	RWZ	CAX-NAQ	-7.69	1.34	1.47
2	C	401	FPS	PA-O1A	3.39	1.54	1.46

The worst 5 of 39 bond angle outliers are listed below:

Mol	Chain	Res	Type	Atoms	Z	Observed(°)	Ideal(°)
3	B	402	RWZ	CAC-CAS-CAJ	4.59	123.19	115.23
3	D	402	RWZ	CAI-NAQ-CAX	4.35	120.02	114.03

Continued on next page...

Continued from previous page...

Mol	Chain	Res	Type	Atoms	Z	Observed(°)	Ideal(°)
3	C	402	RWZ	CAI-NAQ-CAX	4.21	119.82	114.03
3	C	402	RWZ	CAC-CAS-CAJ	4.20	122.52	115.23
3	A	502	RWZ	CAG-NAP-CAH	4.18	121.32	112.85

There are no chirality outliers.

5 of 56 torsion outliers are listed below:

Mol	Chain	Res	Type	Atoms
2	A	501	FPS	C2-C3-C5-C6
2	A	501	FPS	C4-C3-C5-C6
2	B	401	FPS	PA-O3A-PB-O3B
3	A	502	RWZ	CAF-CAJ-CAS-CAC
3	A	502	RWZ	CAF-CAJ-CAS-CAE

There are no ring outliers.

8 monomers are involved in 21 short contacts:

Mol	Chain	Res	Type	Clashes	Symm-Clashes
3	C	402	RWZ	2	0
3	B	402	RWZ	4	0
2	D	401	FPS	4	0
3	A	502	RWZ	3	0
2	A	501	FPS	1	0
2	B	401	FPS	4	0
3	D	402	RWZ	4	0
2	C	401	FPS	3	0

The following is a two-dimensional graphical depiction of Mogul quality analysis of bond lengths, bond angles, torsion angles, and ring geometry for all instances of the Ligand of Interest. In addition, ligands with molecular weight > 250 and outliers as shown on the validation Tables will also be included. For torsion angles, if less than 5% of the Mogul distribution of torsion angles is within 10 degrees of the torsion angle in question, then that torsion angle is considered an outlier. Any bond that is central to one or more torsion angles identified as an outlier by Mogul will be highlighted in the graph. For rings, the root-mean-square deviation (RMSD) between the ring in question and similar rings identified by Mogul is calculated over all ring torsion angles. If the average RMSD is greater than 60 degrees and the minimal RMSD between the ring in question and any Mogul-identified rings is also greater than 60 degrees, then that ring is considered an outlier. The outliers are highlighted in purple. The color gray indicates Mogul did not find sufficient equivalents in the CSD to analyse the geometry.

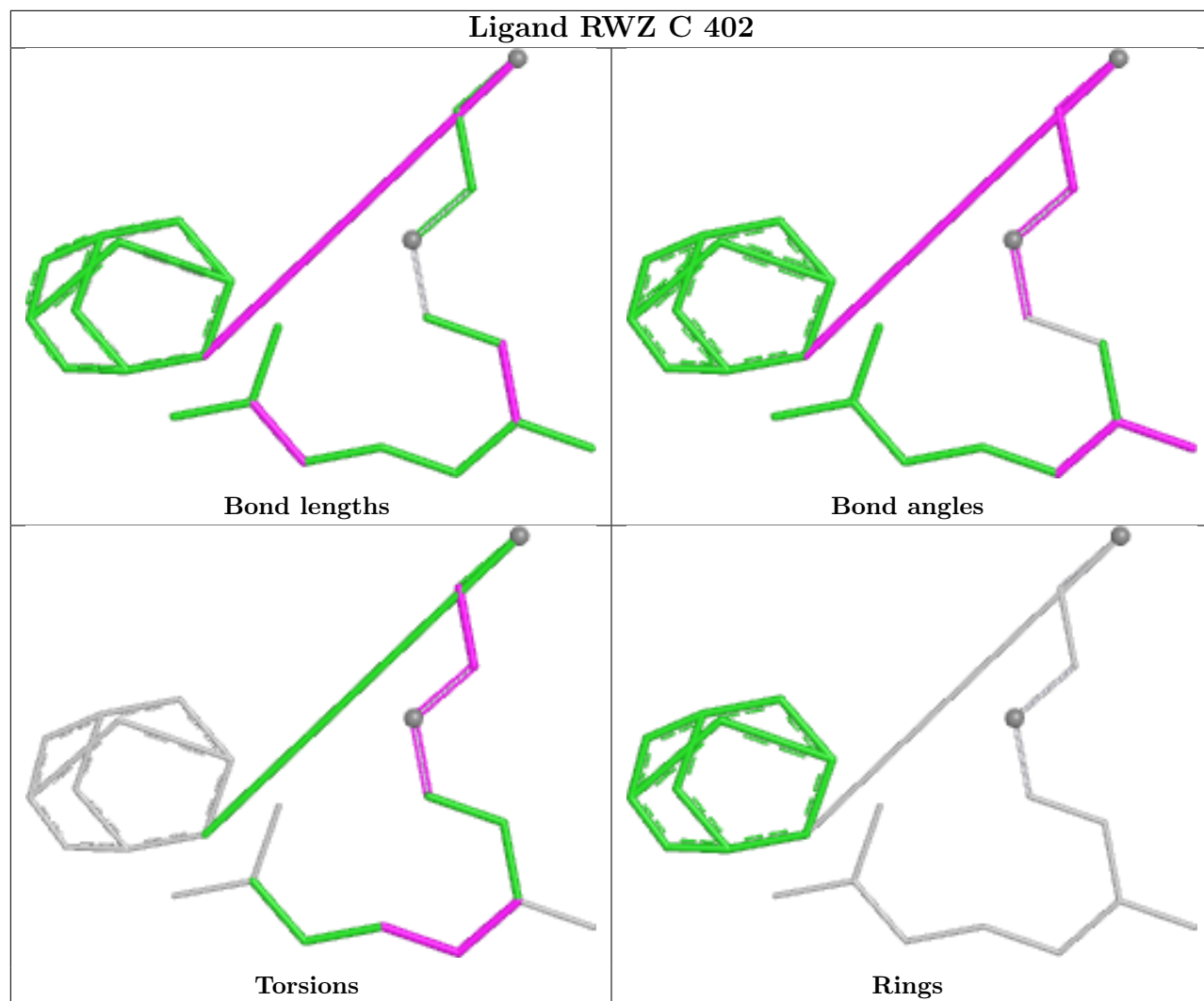

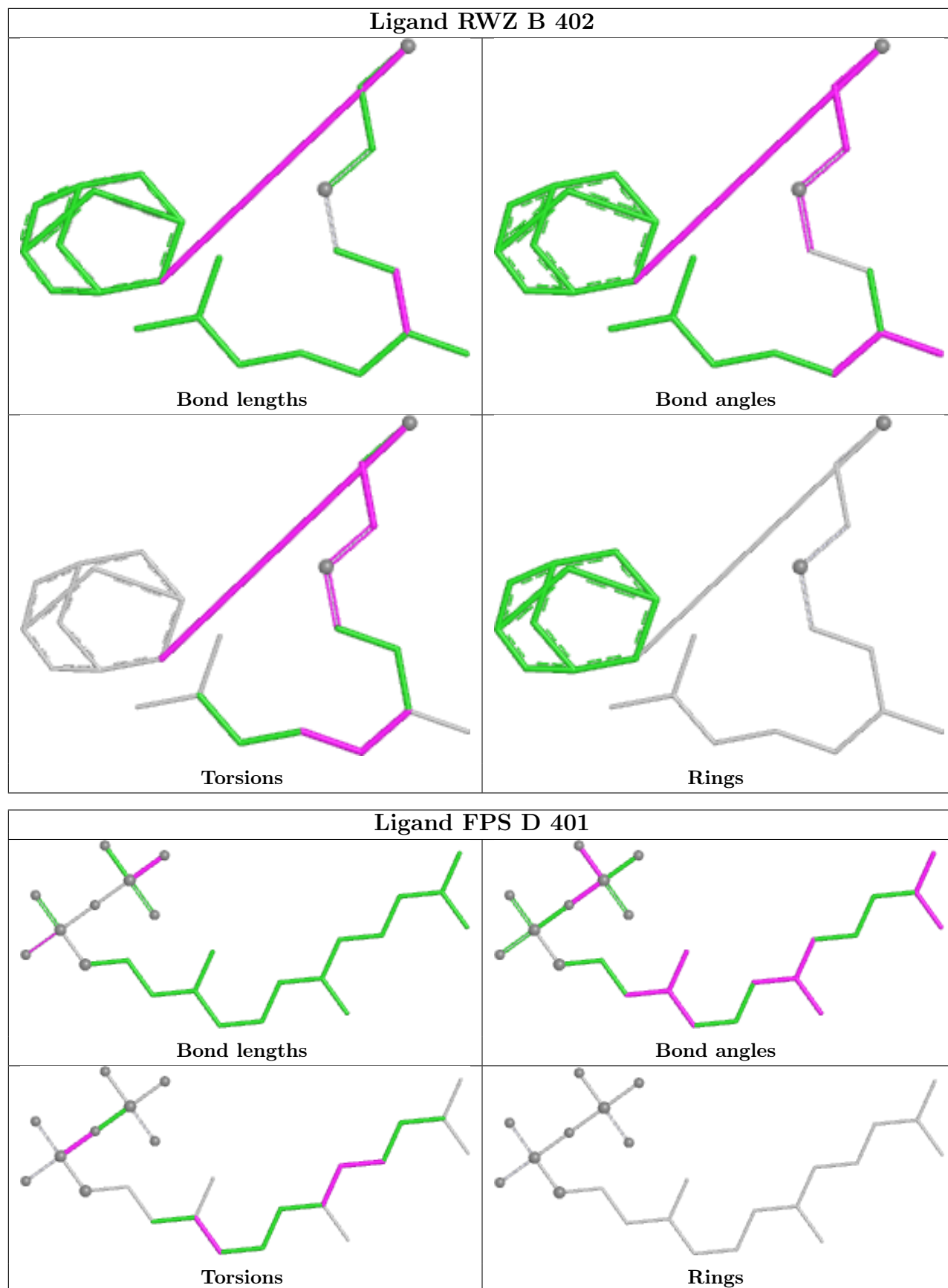

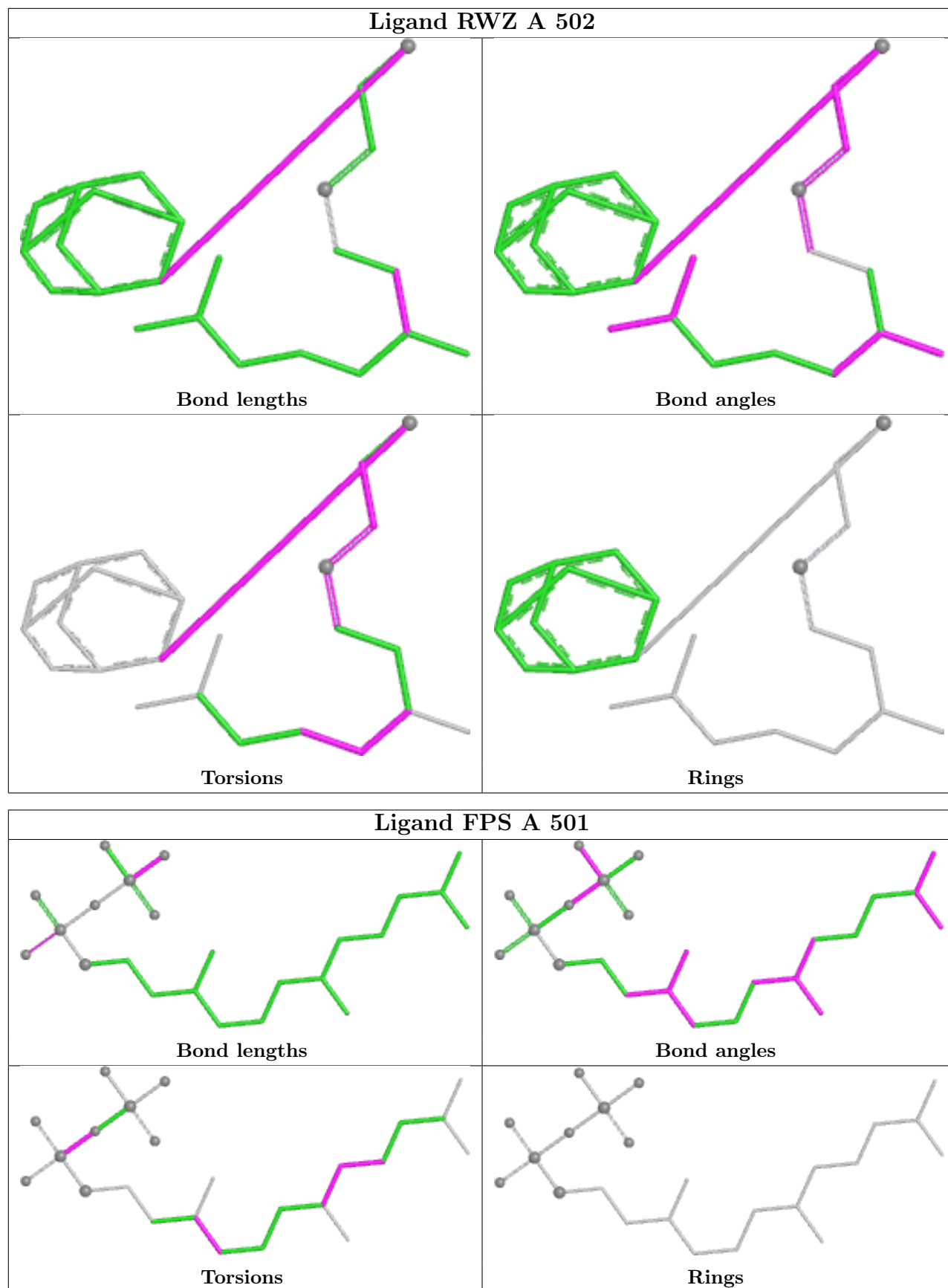

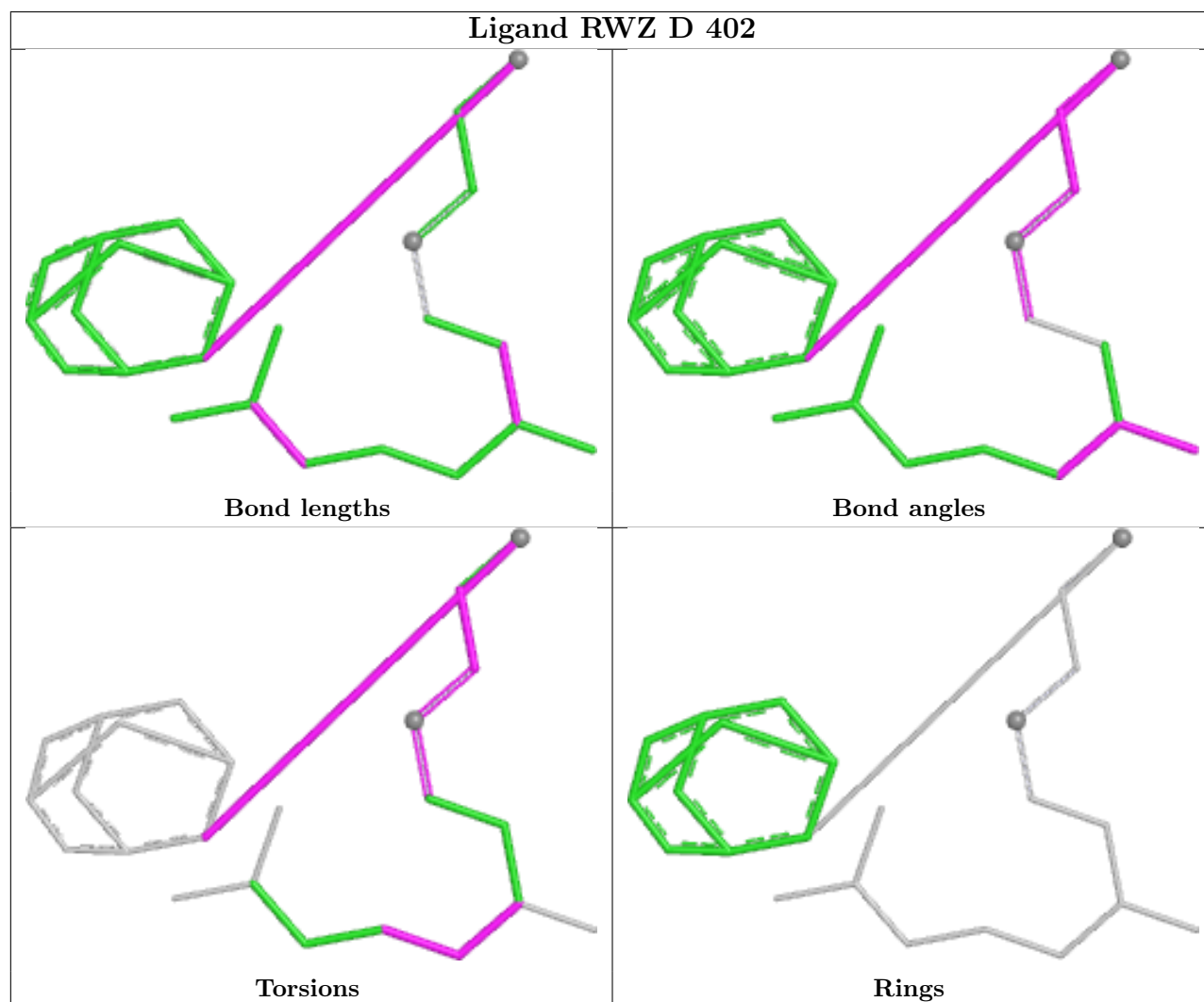
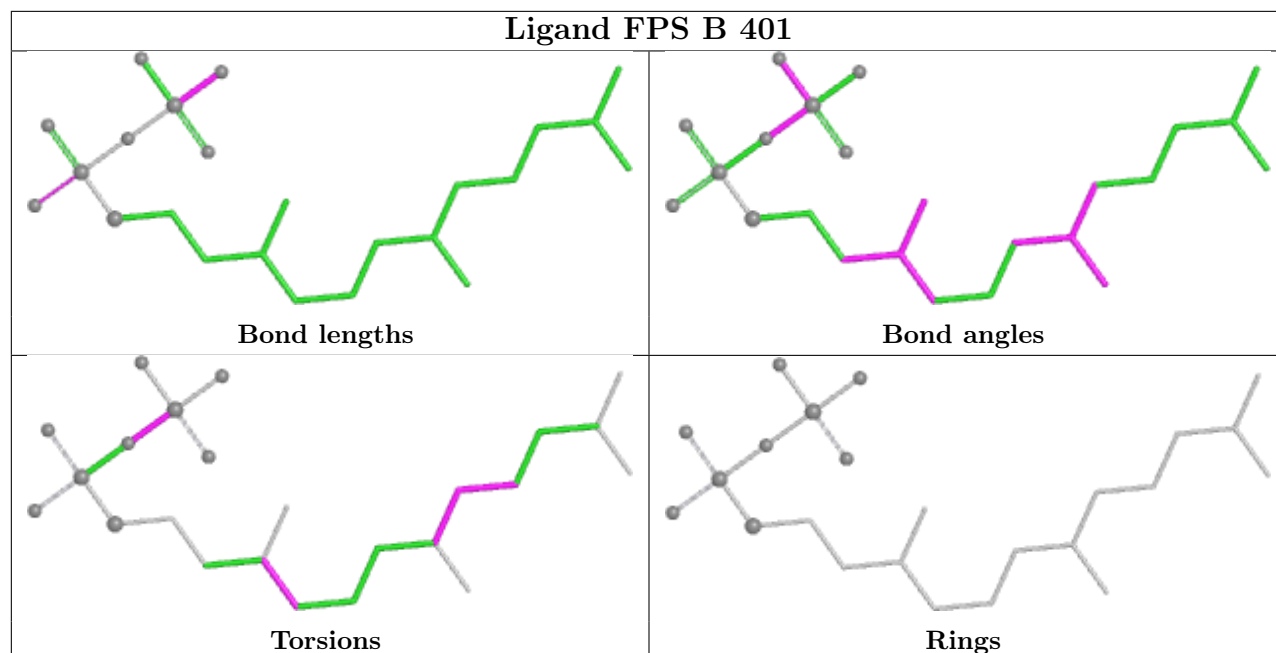

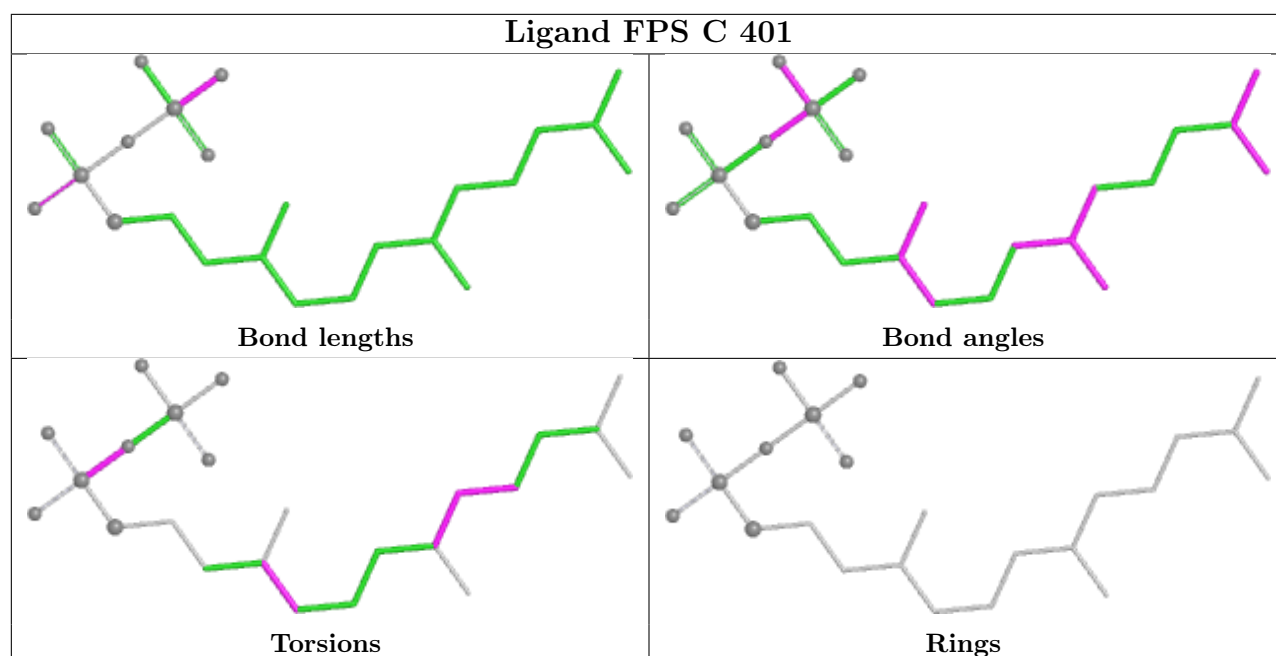

5.7 Other polymers [i](#)

There are no such residues in this entry.

5.8 Polymer linkage issues [i](#)

There are no chain breaks in this entry.

6 Fit of model and data [i](#)

6.1 Protein, DNA and RNA chains [i](#)

In the following table, the column labelled '#RSRZ > 2' contains the number (and percentage) of RSRZ outliers, followed by percent RSRZ outliers for the chain as percentile scores relative to all X-ray entries and entries of similar resolution. The OWAB column contains the minimum, median, 95th percentile and maximum values of the occupancy-weighted average B-factor per residue. The column labelled 'Q < 0.9' lists the number of (and percentage) of residues with an average occupancy less than 0.9.

Mol	Chain	Analysed	<RSRZ>	#RSRZ>2	OWAB(Å ²)	Q<0.9
1	A	341/365 (93%)	-0.26	0 100 100	24, 44, 63, 80	0
1	B	341/365 (93%)	-0.21	0 100 100	20, 44, 75, 86	0
1	C	341/365 (93%)	-0.05	3 (0%) 81 78	26, 51, 88, 97	0
1	D	341/365 (93%)	0.13	1 (0%) 90 88	27, 59, 90, 105	0
All	All	1364/1460 (93%)	-0.10	4 (0%) 90 88	20, 49, 85, 105	0

All (4) RSRZ outliers are listed below:

Mol	Chain	Res	Type	RSRZ
1	C	105	VAL	2.8
1	D	81	VAL	2.4
1	C	114	LEU	2.1
1	C	106	GLY	2.1

6.2 Non-standard residues in protein, DNA, RNA chains [i](#)

There are no non-standard protein/DNA/RNA residues in this entry.

6.3 Carbohydrates [i](#)

There are no oligosaccharides in this entry.

6.4 Ligands [i](#)

In the following table, the Atoms column lists the number of modelled atoms in the group and the number defined in the chemical component dictionary. The B-factors column lists the minimum, median, 95th percentile and maximum values of B factors of atoms in the group. The column labelled 'Q < 0.9' lists the number of atoms with occupancy less than 0.9.

Mol	Type	Chain	Res	Atoms	RSCC	RSR	B-factors(\AA^2)	Q<0.9
2	FPS	B	401	24/24	0.76	0.19	45,90,119,119	0
2	FPS	C	401	24/24	0.78	0.19	79,107,123,124	0
2	FPS	A	501	24/24	0.80	0.15	48,81,111,112	0
2	FPS	D	401	24/24	0.80	0.18	64,102,126,126	0
3	RWZ	C	402	24/24	0.85	0.20	80,93,98,99	0
3	RWZ	B	402	24/24	0.86	0.16	57,72,74,74	0
3	RWZ	A	502	24/24	0.90	0.14	56,58,61,63	0
3	RWZ	D	402	24/24	0.90	0.16	65,78,80,81	0

The following is a graphical depiction of the model fit to experimental electron density of all instances of the Ligand of Interest. In addition, ligands with molecular weight > 250 and outliers as shown on the geometry validation Tables will also be included. Each fit is shown from different orientation to approximate a three-dimensional view.

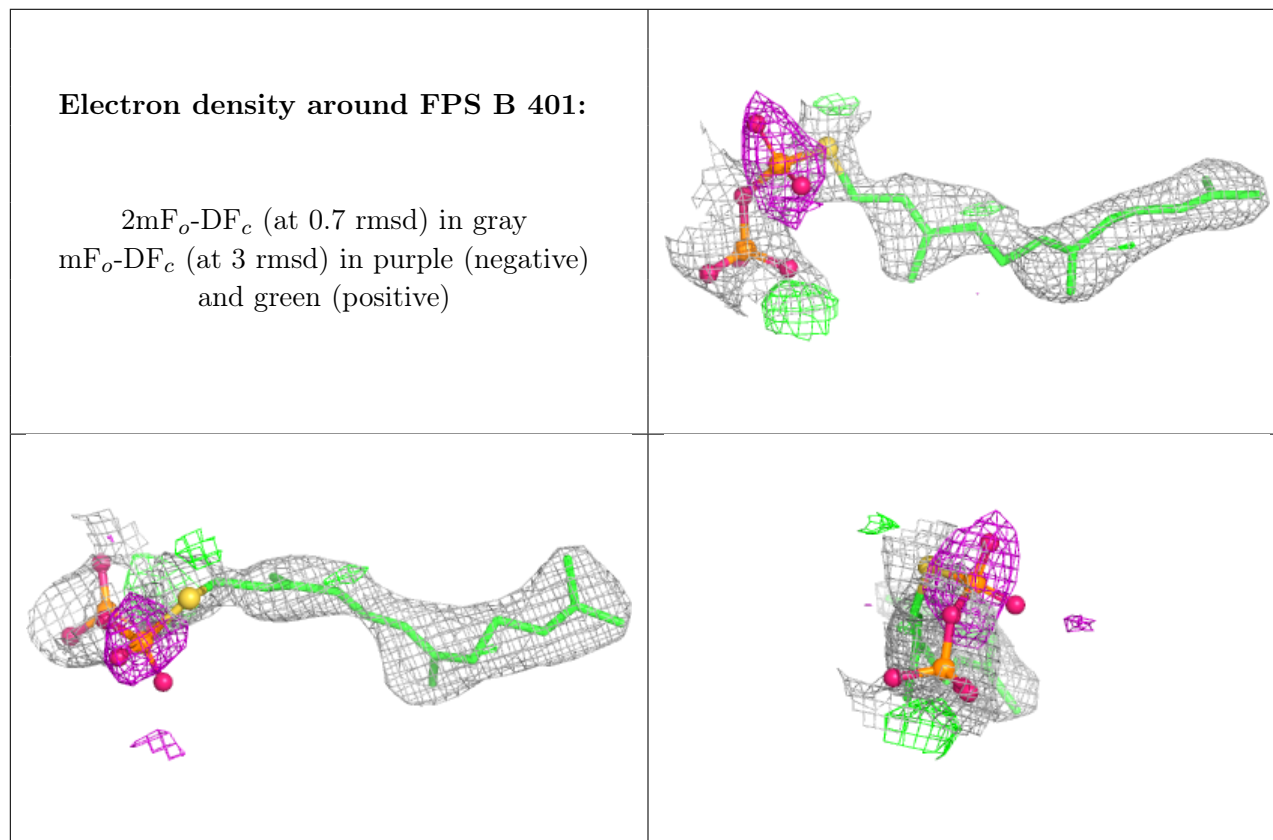

Electron density around FPS C 401:

$2mF_o-DF_c$ (at 0.7 rmsd) in gray
 mF_o-DF_c (at 3 rmsd) in purple (negative)
and green (positive)

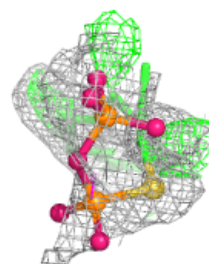
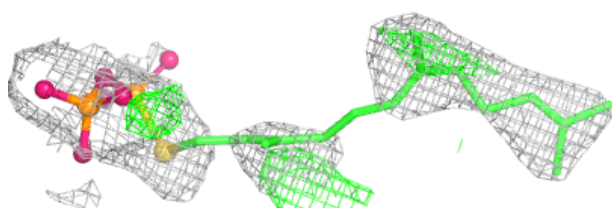
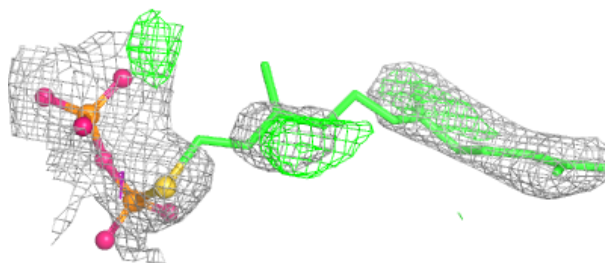
**Electron density around FPS A 501:**

$2mF_o-DF_c$ (at 0.7 rmsd) in gray
 mF_o-DF_c (at 3 rmsd) in purple (negative)
and green (positive)

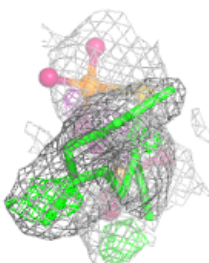
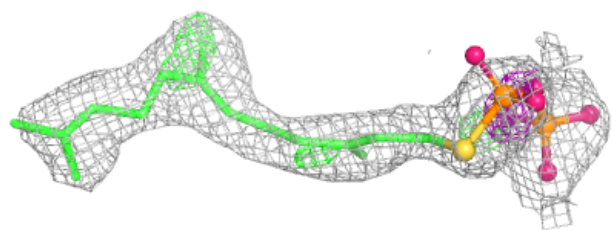
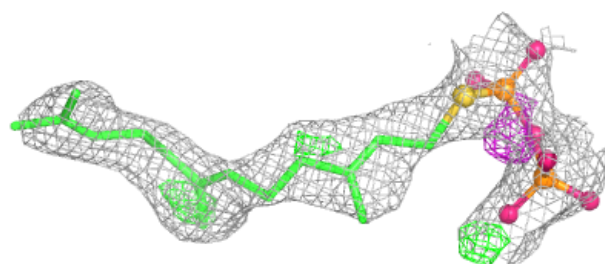

Electron density around FPS D 401:

$2mF_o-DF_c$ (at 0.7 rmsd) in gray
 mF_o-DF_c (at 3 rmsd) in purple (negative)
and green (positive)

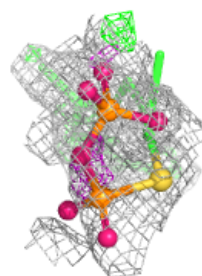
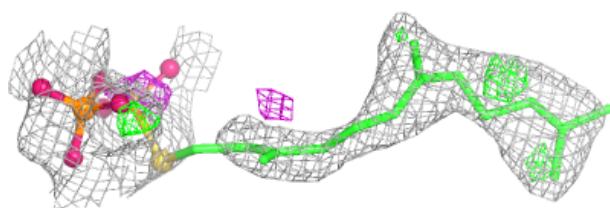
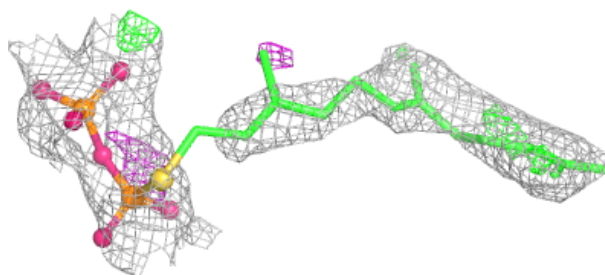
**Electron density around RWZ C 402:**

$2mF_o-DF_c$ (at 0.7 rmsd) in gray
 mF_o-DF_c (at 3 rmsd) in purple (negative)
and green (positive)

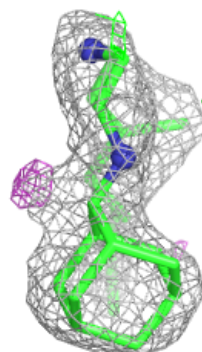
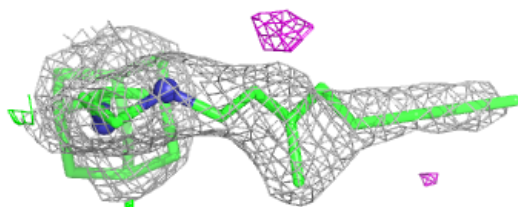
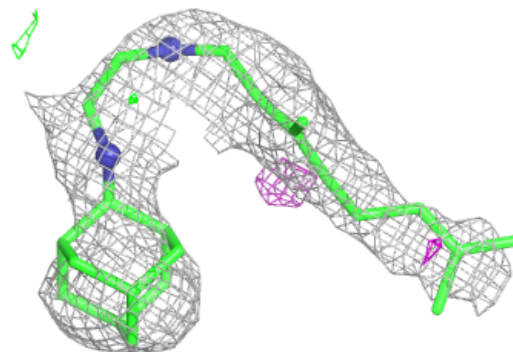

Electron density around RWZ B 402:

$2mF_o-DF_c$ (at 0.7 rmsd) in gray
 mF_o-DF_c (at 3 rmsd) in purple (negative)
and green (positive)

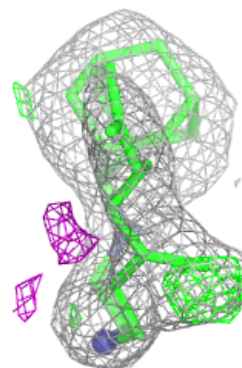
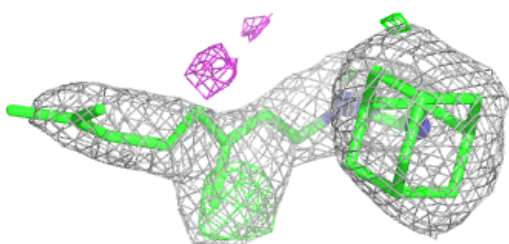
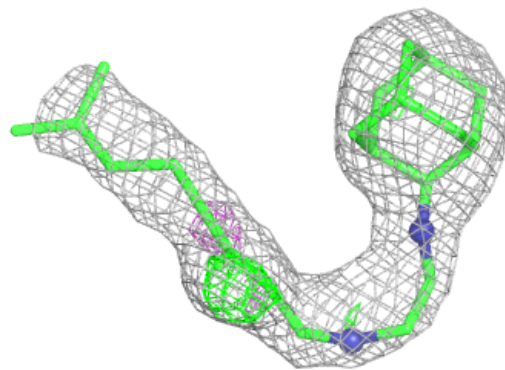
**Electron density around RWZ A 502:**

$2mF_o-DF_c$ (at 0.7 rmsd) in gray
 mF_o-DF_c (at 3 rmsd) in purple (negative)
and green (positive)

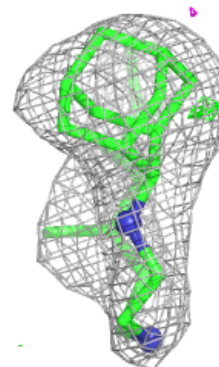
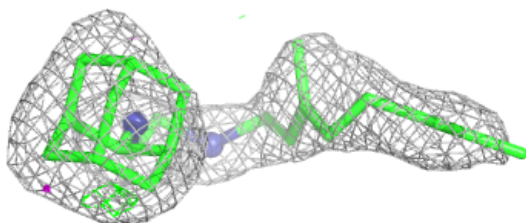
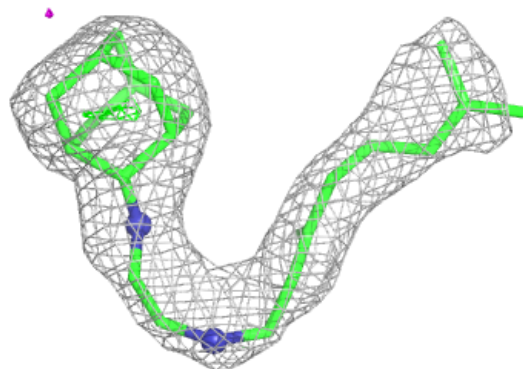

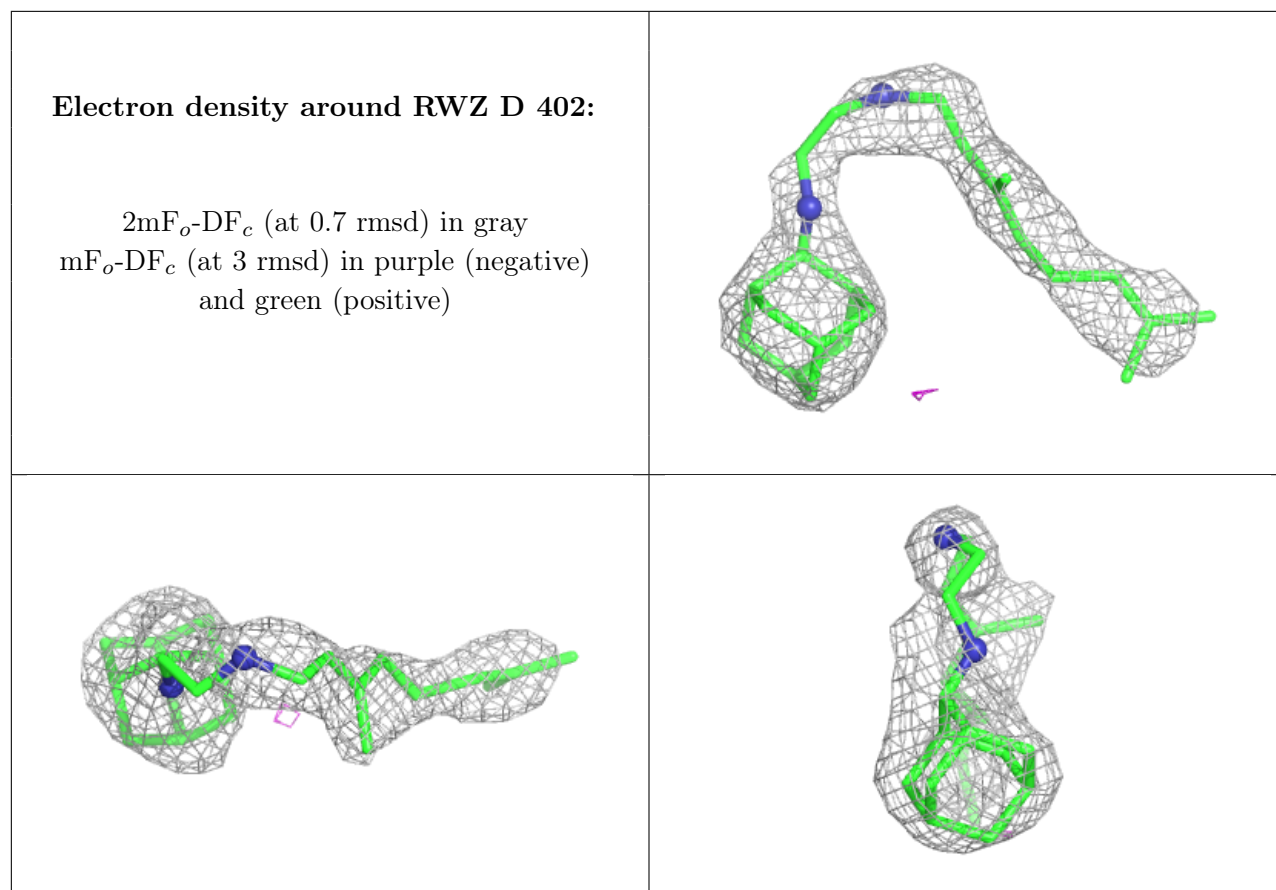

6.5 Other polymers [\(i\)](#)

There are no such residues in this entry.